

**UOP RUSSELL LLC**

Tulsa, Oklahoma

JOB NO: J-447  
 CLIENT: UOP Russell  
 SUBJECT: 60 MM Cryo Plant

DATE: 7/14/2011  
 BY: JRG

**POSITIVE DISPLACEMENT PUMP**

Tag No.	P-609		
Service	Methanol Injection Pump		
Quantity	One		
<b>Fluid Properties at Operating Temp.</b>			
Flow Norm / Design	5 GPH (1)		
Operating Temperature °F	Ambient		
Specific Gravity	0.78 - 0.8		
Suction Pressure PSIG	0		
Discharge Pressure PSIG	1050		
Viscosity cP	1 cP @ 100		
Vapor Pressure PSIA	Nil		
Corrosion / Erosion Due To	Nil		
<b>Pump Mechanical Data</b>			
Mat'l Case / Plung. or Rot.	SS	Teflon diaphragm	
Fluid End MWP @ °F	1400 @ 150		
Inlet Connection	1/2" NPTF		
Outlet Connection	1/2" NPTF		
Plunger Size Des/Max/No	Diaphragm		
Stroke x RPM			
Hydraulic HP / Design Efficiency	0.051		
BHP Design			
NPSH Req'd / Available		Flooded	
Rod / Shaft Seal Type	Diaphragm		
Drive (Coupling / Belt)	Close Coupled		
Pulsation Dampeners	No		
Fluid End Lube	No		
PSV Supplied	With pump		
PSV Location / Set Pressure	Internal / 1400		
<b>Driver Data</b>			
Driver Type	Induction motor		
Driver HP @ RPM	1/2 @ 1750		
Electric Power V / Ph / Hz	460 / 3 / 60		Class 1 Div. 2
Motor Enclosure	Ex. Pr.		
Ambient Temp. Min / Max (°F)	-20 / 110		
Site Elevation Ft	3000 ft		
Space Heater	No		
Manufacturer	Neptune		
Model No.	525-S-N3-100745		
Min. Continuous Flow GPM			

**NOTES:**

- 1) The pump flow/stroke length shall be continuously adjustable from 0-100% while the pump is running.

REVISION	0		
ENGINEER/DATE	JRG	07/14/11	
ISSUED FOR	Purchase		



**UOP Russell LLC**

**7130 SOUTH LEWIS AVE. SUITE 500**

**Tulsa, OK 74136**

**Tag #: P-609**

**PO No. : 4500806191**

**Installation, Operation, and  
Maintenance Manual  
Rev 0**

**DXP Job No.: 9201851**

**Proposal No.:**

**Date Prepared: 4-22-2019**

**Office No.: (918) 446-5515**

**Direct Line: (713) 396-8105**

**Fax No.: (918) 446-0338**

---

**TABLE OF CONTENTS**

<b><i>Drawings</i></b> <b><i>-General Arrangement Drawing</i></b>	<b>1</b>
<b><i>-Scope of Work</i></b>	<b>2</b>
<b><i>-Pump Curve</i></b>	<b>3</b>
<b><i>-Pump Manual</i></b> <b><i>- Pump Brochure</i></b>	<b>4</b>
<b><i>-Motor Data</i></b>	<b>5</b>

# **Section**

# **1**

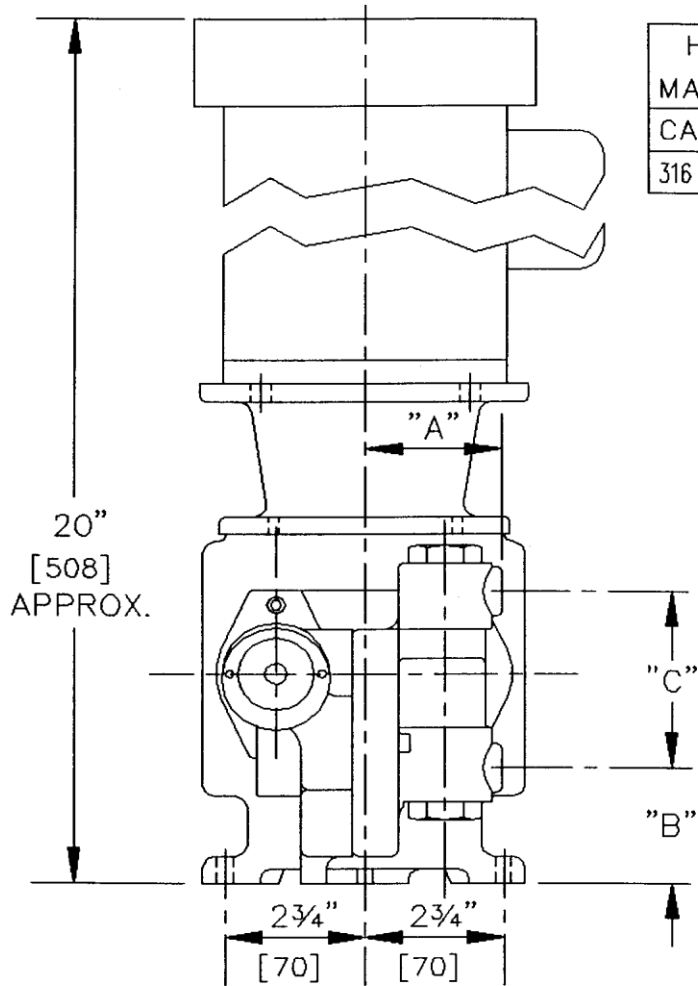

HEAD MATERIAL	DIMENSIONS		
	"A"	"B"	"C"
CAST IRON	2 $\frac{7}{8}$ " [73]	2 $\frac{7}{16}$ " [62]	3 $\frac{1}{16}$ " [94]
316 SS & C-20	2 $\frac{1}{2}$ " [64]	2 $\frac{3}{16}$ " [56]	3 $\frac{7}{8}$ " [98]

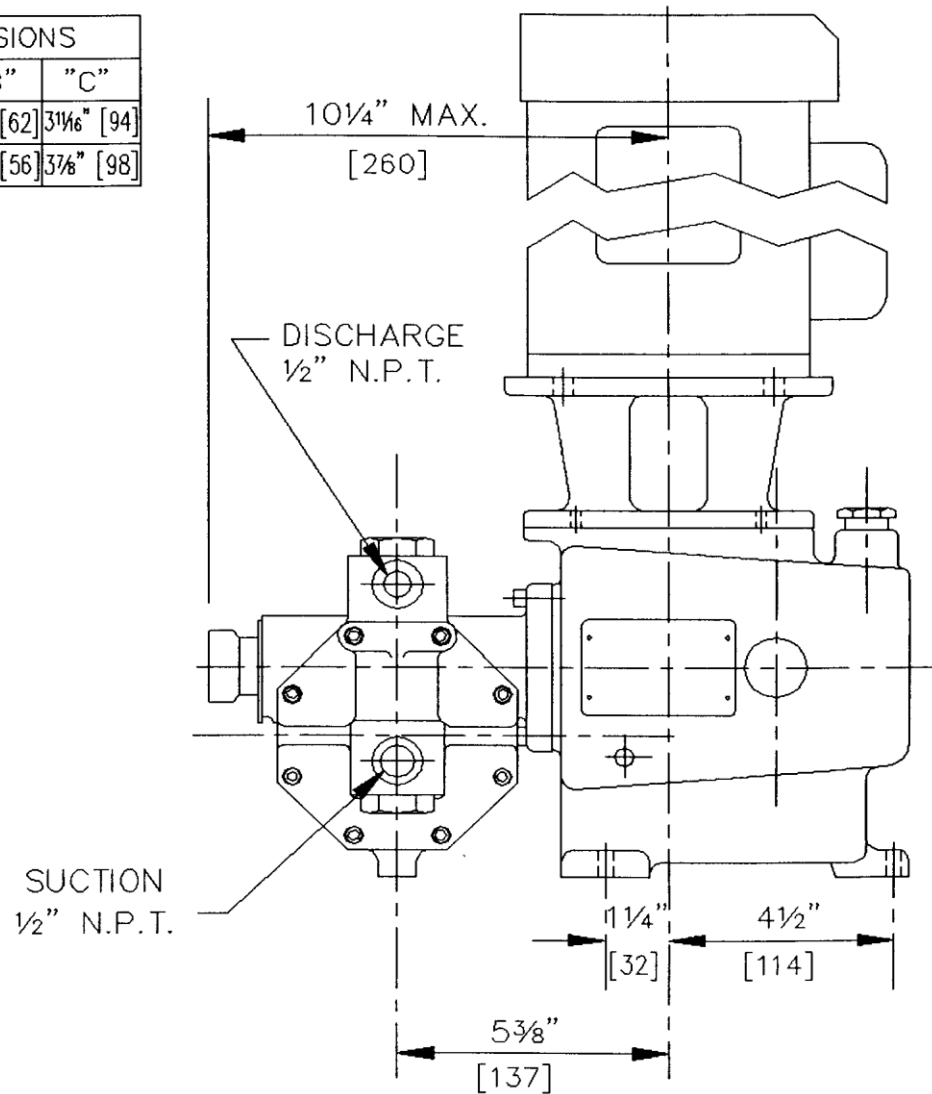

PUMP DATA		MOTOR DATA	
MODEL NUMBER	: 525-S-N3HP-100745	H.P.	: 1/2
MAX PSI	: 1500	R.P.M.	: 1725
CAPACITY ( GPH )	: 7	PHASE	: 3
<b>WETTED MATERIALS</b>		VOLTAGE	: 230/460
HEAD	C.IRON <input type="checkbox"/> 316SS <input checked="" type="checkbox"/> C-20 <input type="checkbox"/>	FREQUENCY	: 60
VALVES	316SS <input checked="" type="checkbox"/> C-20 <input type="checkbox"/>	ENCLOSURE	: EXP
CHECKS	316SS <input checked="" type="checkbox"/> C-20 <input type="checkbox"/>	CUSTOMER	: UOP RUSSELL LLC
DIAPHRAGM	TEFLON	ITEM NO.	: P-609
O-RINGS	VITON	JOB NO.	: J417

PO# 4500806191  
 Proj: J-488XX  
 Item: P-609  
 Order: 9201851

NEPTUNE CHEMICAL PUMP COMPANY	
LANSDALE, PA	19446
SERIES 500 SIMPLEX PUMP (METAL HEAD)	
WITH FLANGE MOUNTED MOTOR	
DRAWING NUMBER HP-1096	

# **Section**

# **2**

### Scope of Supply

Item-	P-609 Methanol Injection
Liquid-	Methyl Alcohol @ 0.79-0.80 S.G. Ambient Temp.
Flow-Discharge	7 GPH / 990 PSIG

- **Pump** - Neptune, Model 525-S-N3, 316 SS Liquid Head, Teflon Diaphragm
- **Connections** - 1/2" NPTF Inlet and Outlet Connections
- **Flange** - C-Face Motor Adapter " FA "
- **Motor** - 1/2 Hp @ 1725 rpm 3/60/230-460V, TEFC, 56C Frame
- **Complete Pump Model #** - 525-S-N3HP-100745-FA PSV Set Press. 1400

# Section

# 3

# TYP. 525 Pump @ 60Hz

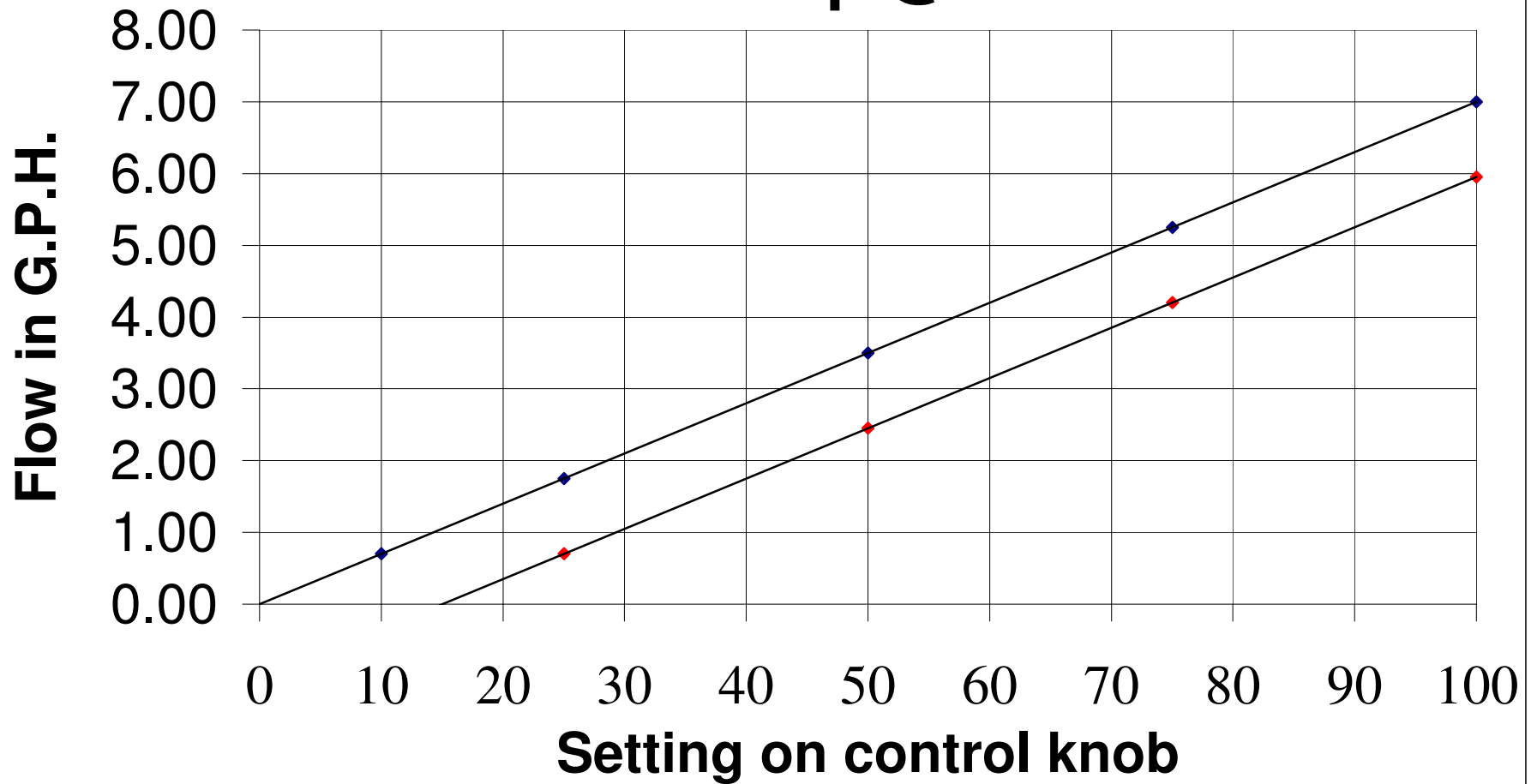

- ◆ typical setting point @ 100 psi
- ◆ typical setting point @ 1500 psi
- Linear line through points @ 100psig.
- Linear line through points @ 1500 psig

# Section

# 4

# OPERATING & INSTRUCTION MANUAL

## NEPTUNE SERIES 500 PUMPS MODEL 481 THRU 547

500-A, 500-D, 500-E, 500-S and 500-VS Types



  
**Neptune**

CHEMICAL PUMP CO., INC.

204, Dekalb Pike,  
Lansdale, PA 19446

Tel.: 215-699-8700 • FAX: 215-699-0370

# **WARNING**

**LOCKOUTS ARE REQUIRED BEFORE  
SERVICING THIS EQUIPMENT.**

## **SAFETY INSTRUCTIONS:**

**Shut off/Lockout pump Power before Servicing.  
Be certain pump isolation valves are  
Closed and chemical is shut off.  
Bleed pressure before servicing.**

# TABLE OF CONTENTS

SECTION	PARAGRAPH		PAGE
I	—	<b>GENERAL DESCRIPTION</b>	3
		<b>LIMITED WARRANTY</b>	4
		<b>PARTS ORDERING INSTRUCTIONS</b>	5
II	—	<b>INSTALLATION INSTRUCTIONS</b>	6
	1.0	GENERAL	6
	2.0	SUCTION PIPING	7
	3.0	DISCHARGE PIPING	8
	4.0	ADJUSTMENT OF INTERNAL RELIEF VALVE	8
	5.0	INSTALLATION OUTDOORS	10
	6.0	START-UP, FLOODED SUCTION	10
	7.0	START-UP, SUCTION LIFT	11
	8.0	START-UP, AFTER SUCTION HAS RUN DRY	11
III	—	<b>NORMAL MAINTENANCE AND DISASSEMBLY INSTRUCTIONS</b>	12
	9.0	MAINTENANCE	12
	10.0	REMOVAL OF VALVE CARTRIDGES	12
	11.0	CLEANING OF VALVE CARTRIDGES	12
	12.0	REPLACING OF VALVE CARTRIDGES	12
	13.0	PROCEDURE FOR REPLACING CONTROL ROD AND SEALING PLATE “O” RINGS	13
	14.0	REMOVAL OF PUMP HEAD AND REPLACEMENT OF DIAPHRAGM	14
	15.0	REMOVAL OF STANDARD MOTOR	15
IV	16.0	<b>MOTOR OPERATING CONDITIONS</b>	16
V	—	<b>TROUBLE SHOOTING CHART</b>	17
VI	—	<b>SPECIAL INSTRUCTIONS FOR PUMPS WITH ELECTRIC OR PNEUMATIC STROKE CONTROL</b>	19
	17.0	FUNCTION OF THE PNEUMATIC STROKE CONTROL UNIT	19
VII	18.0	<b>PARTS LIST</b>	20
VIII	—	<b>DRAWINGS</b>	23
APPENDIX	—	<b>ADDITIONAL INSTRUCTIONS FOR VARIOUS MODEL OPTIONS</b>	
		SERIES 500-E-AR “dia-PUMP”	26
		SERIES 500-E “dia-PUMP”	27
		SERIES 500-A “dia-PUMP”	28
		SERIES 500-VS “dia-PUMP”	30
		MODEL 481 “dia-PUMP”	31
		DOUBLE DIAPHRAGM OPTION	33

## SECTION I GENERAL DESCRIPTION

The Neptune Series 6000 “dia-PUMP” is a reliable metering pump of the high-pressure diaphragm type. Under constant conditions of temperature, pressure, and capacity adjustment settings, a +/- 1% metered discharge volume is maintained.

A plunger reciprocating at a fixed stroke displaces hydraulic fluid, which actuates a flexible, chemically inert, Teflon<sup>®</sup> diaphragm to create pumping action. The capacity of the pump is regulated by controlling the volume of hydraulic fluid, which bypasses the diaphragm cavity.

Capacity adjustment can be made manually or automatically by instrument signal.

Metering accuracy is maintained by a control rod, which allows hydraulic fluid replacement and air venting automatically with each stroke, while also taking into account temperature changes of the hydraulic fluid. Metering accuracy is also insured by the use of double ball check valves on the suction and discharge of the pump.

**PLEASE READ THE INSTRUCTION MANUAL COMPLETELY BEFORE INSTALLING THE PUMP.**

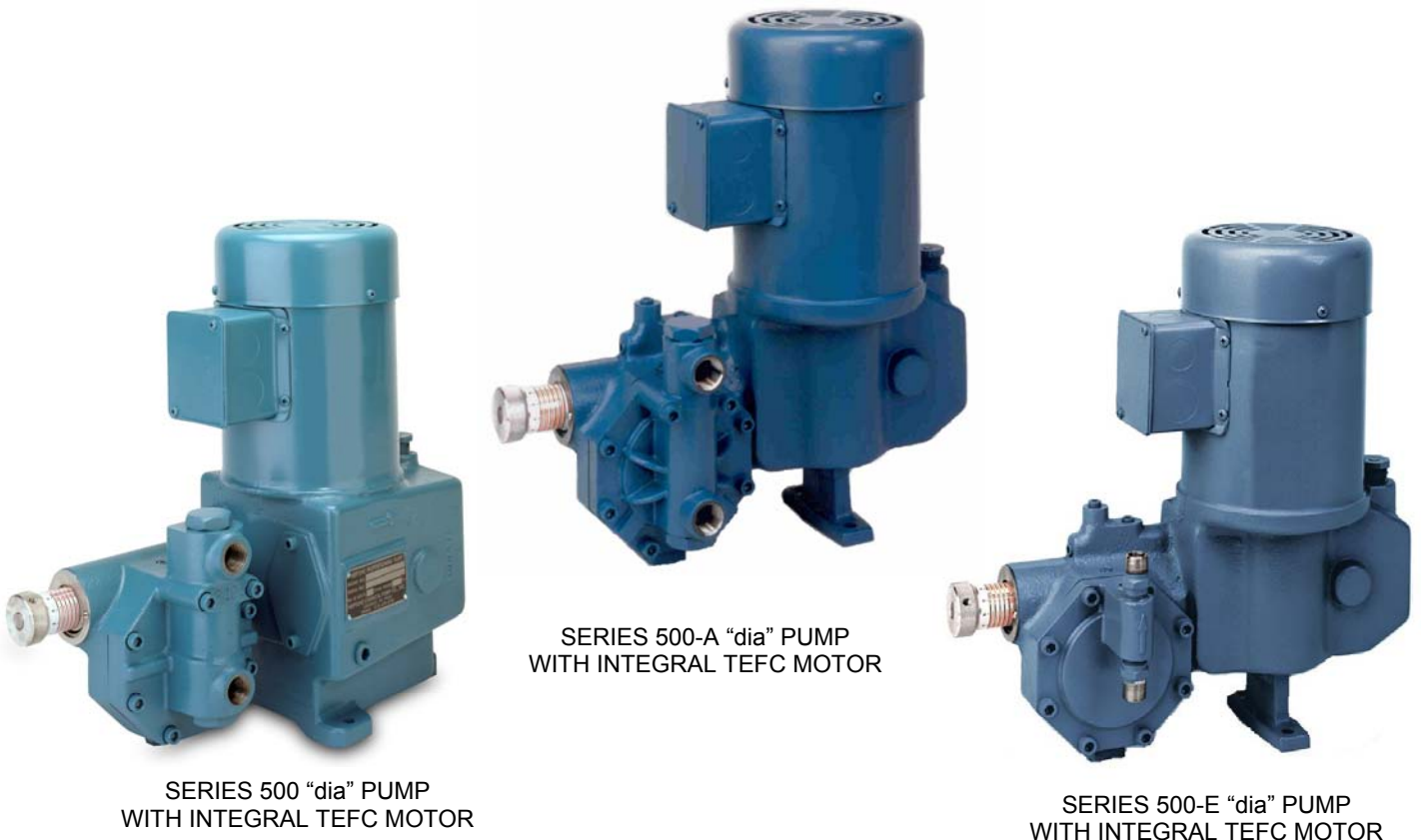

The text and illustrations in the main body of this manual are based upon the Series 500 pump, shown at left above. The Series 500-A and 500-E pumps are very similar to the Series 500 pump. The liquid ends are interchangeable.

Please refer to Appendix for all Models other than 500-S or 500-D.

Models 500-A, 500-E, 500-VS, 481 and the Double Diaphragm Option are described in the Appendix.

**SECTION I  
NEPTUNE CHEMICAL PUMP COMPANY  
LIMITED WARRANTY**

All Neptune Pumps are tested at the factory prior to shipment. Each part used in their construction has been carefully checked for workmanship.

If the pump is installed properly, Neptune Chemical Pump Company, Inc. warrants to the purchaser of this product for a period of three years from the date of shipment, this product shall be free of defects in material and/or workmanship, as follows:

1. Neptune Chemical Pump Company, Inc. will replace, at no charge, any part that fails due to a defect in material and/or workmanship during the warranty period, FOB our factory, Lansdale, Pennsylvania. To obtain warranty service, you must forward the defective parts to the factory for examination, freight pre-paid.<sup>1</sup>
2. This warranty period does not cover any product or product part, which has been subject to accident, misuse, abuse or negligence. Neptune Chemical Pump Company, Inc. shall only be liable under this warranty if the product is used in the manner intended by the manufacturer as specified in the written instructions furnished with this product.

Any express warranty not provided in this warranty document, and any remedy for breach of contract that, but for this provision, might arise by implication or operation of law, is hereby excluded and disclaimed. Under no circumstances shall Neptune Chemical Pump Company, Inc. be liable to purchaser or any other person for any charge for labor, repairs, or parts, performed or furnished by others, nor for any incidental consequential damages, whether arising out of breach of warranty, express or implied, a breach of contract or otherwise. Except to the extent prohibited by applicable law, any implied warranty of merchantability and fitness for a particular purpose are expressly limited in duration to the duration of this limited warranty.

Some states do not allow the exclusion or limitation of incidental or consequential damages, or allow limitations on how long any implied warranty lasts, so the above limitations may not apply to you. This warranty gives you specific legal rights, and you may have other rights, which may vary from state to state.

**IMPORTANT**

SHOULD IT BE NECESSARY TO SEND THE PUMP TO THE FACTORY FOR REPAIR OR MAINTENANCE REBUILDING; DRAIN ALL OIL AND CHEMICAL FROM PUMP BEFORE SHIPPING. FAILURE TO DO SO CAN CAUSE EXTENSIVE DAMAGE TO THE MOTOR.

<sup>1</sup>SEE IMPORTANT NOTICE -RETURN GOODS AUTHORIZATION

**IMPORTANT NOTICE  
RETURN GOODS AUTHORIZATION**

- (1) All equipment returned to Neptune Chemical Pump Company, Inc. requires proper Returned Goods Authorization Number (RGA) and tags.
- (2) All equipment returned to the factory for repair or service must first be thoroughly flushed and have all chemical contact areas neutralized.
- (3) All equipment, which has been in contact with chemicals, must be accompanied by a copy of the Chemical Product Material Safety Data Sheet (MSDS).
- (4) Failure to comply with the above instructions will result in equipment being returned to sender, freight collect, without service.

## PARTS ORDERING INSTRUCTIONS

The complete model number and serial number of the pump must be furnished to insure prompt and accurate parts service. These numbers are found on the name plate (sample below) located on the side of the pump. Refer to **Section VII** for complete parts lists.

<b>NEPTUNE PROPORTIONING PUMP</b>					
MODEL NO.	XXXXXX				
SERIAL NO.	XXXXXX				
MAX. CAP. EACH CYL.	XXX	GPH	MAX. PRESSURE	XXX	PSI
<b>NEPTUNE CHEMICAL PUMP CO., INC.</b>					
LANSDALE, PA 19446					
PHONE (215) 699-8700					

**Send all orders or inquiries for parts to:**

Parts Department  
Neptune Chemical Pump Company, Inc.  
P.O. Box 247  
Lansdale, PA 19446  
Tel.: 215-699-8700  
1 -888-3NEPTUNE (888-363-7886)  
FAX: 215-699-0370  
Web: [www.neptune1.com](http://www.neptune1.com)  
Email: [pump@neptune1.com](mailto:pump@neptune1.com)

**NOTE:** PLEASE SUPPLY BOTH MODEL AND SERIAL NUMBERS.

## SECTION II

### INSTALLATION INSTRUCTIONS

#### 1.0 GENERAL

- 1.0.1 When unpacking a pump or chemical feed system, be certain that no parts are thrown away. Examine the equipment for possible damage. If damage has occurred, file claim with the common carrier within 24 hours. Neptune will assist in estimating the repair costs.
- 1.0.2 The “dia-Pump” should be located so as to avoid an ambient temperature above 120°F, 50°C. Free air circulation is important when considering the location of the pump.
- 1.0.3 The “dia-Pump” should be located on a level surface. Three mounting holes are provided to anchor the pump securely to the mounting surface. PVC head pumps must be mounted on three, one-inch spacers provided.
- 1.0.4 All piping to the pump should be supported to prevent stress on the pump input and out-put fittings.
- 1.0.5 Before connecting the pump, make sure that all fittings are completely clean by flushing thoroughly. Any foreign matter entering the pump can damage the internal parts and severely limit the life of the pump.
- 1.0.6 A “Y” STRAINER MUST BE INSTALLED IN THE SUCTION LINE OF THE PUMP TO INSURE AGAINST FOREIGN MATTER ENTERING THE PUMP. ALL SUCTION LIFT APPLICATIONS REQUIRE A FOOT VALVE STRAINER TO PREVENT LOSS OF PRIME, AND TO PREVENT FOREIGN MATERIAL FROM ENTERING THE PUMP.
- 1.0.7 Shut-off valves and unions should be placed in the suction and discharge lines to facilitate servicing the pump.
- 1.0.8 Care should be exercised when piping to PVC head pumps. In cases where vibration or stress is unavoidable, flexible connections should be used.
- 1.0.9 The electrical supply to the pump must match the motor name plate characteristics. The motor rotation is counter clockwise when viewed from the top of the motor, looking down on the pump. (See Figure 1).
- 1.0.10 Discharge Piping should be the same size or larger than the discharge connection. Suction Piping should be one size larger than the suction connection (1/2” pipe minimum). Limit the total length of the suction line to 3-4 feet suction lift or 6-7 feet flooded suction. Minimum bends, elbows, or other restrictions.

#### **Important**

On single phase integral motors, the rotation is set at the factory and must not be changed.

On three phase integral motors, rotation is determined by noting the fan rotation.

**On some flange mounted motors, the motor rotation may be viewed by removing the cap on the side of the flange. There is no viewing port or coupling access on the close coupled flange mount motors. Rotation is checked by removing the oil fill plug and observing the gear. Correct rotation is indicated by the gear teeth moving downward away from the oil fill hole.**

**Please note Figure 1, indicating the correct rotation. (An arrow on the gear box also indicates proper rotation.) Operation with the incorrect rotation will damage the pump and motor.**

Models 481 and 501 must be installed with a flooded suction. These models will not operate with suction lift.

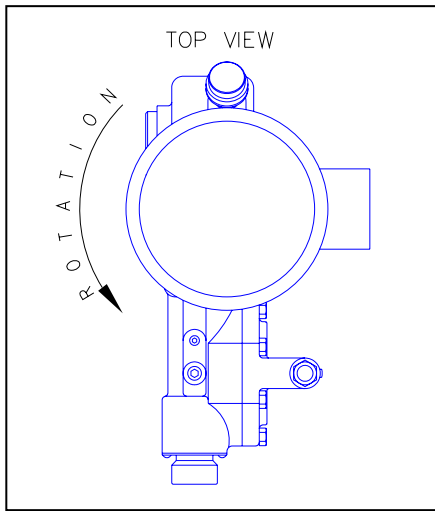

**FIGURE 1**

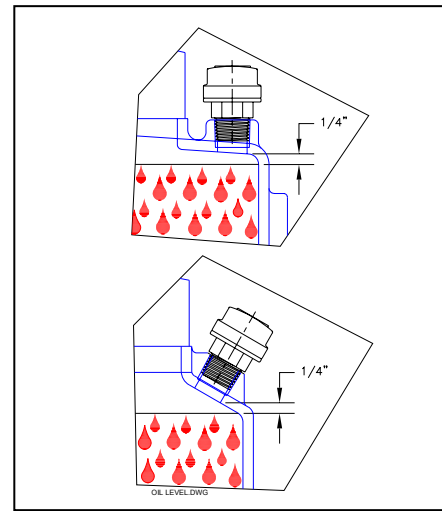

**FIGURE 1A**

1.0.11 Set capacity knob to zero and remove Air Bleed Plug from the top of Oil Chamber, refer to drawings HP-1102 (page 21) for Series 500 and drawing 5024 (page 26) for Series 500-A and 500-E for location of plug. Fill gear box and pump by pouring the hydraulic fluid supplied through the fill opening at the rear of the pump. Pour fluid in slowly until it has reached the correct level per Figure 1A. Do not over fill as this can cause damage to the motor.

Allow a few minutes for the hydraulic fluid work through the oil head and appear at the oil bleed plug. Recheck oil level. When air is purged, reinstall the Air Bleed Plug.

The hydraulic fluid supplied by Neptune is:

EP 68 Gear Oil, Scot Lubricants, 1801 E. Tremont Street, P.O. Box 326, Allentown, PA 18105  
Information: 610-433-2527

Heavier hydraulic fluid is supplied by Neptune for Hi Pressure Systems is EP SAE 90.

Alternate Oils For Standard	Mfg.	Alternate High Pressure Oils
Omala #68	Shell Oil	Omala #220
Mobil Gear #626	Mobil Oil	Mobil Gear #629
Sun EP #68	Sun Oil	Sun Oil #220
Meropa #68	Texaco	Meropa #220

The 90 weight gear oil is used for high-pressure pumps using 1/2 horsepower motors or larger and rated for operation over 1000 PSI.

The 90-weight gear oil is also provided for the 481, 500, and 501 pump models at all pressures.

## 2.0 SUCTION PIPING

2.0.1 The suction piping to the pump must be absolutely air tight. It is suggested that the suction piping be tested with low air pressure and a soap solution to assure that no leaks exist.

2.0.2 NEPTUNE RECOMMENDS THAT THE "dia-Pump" BE OPERATED WITH A FLOODED SUCTION, AS THIS WILL FACILITATE START UP AND INCREASE THE SERVICE LIFE OF THE PUMP. It is, however, possible to operate the "dia-Pump" with a suction lift of up to 5 feet, if absolutely necessary. A FOOT VALVE STRAINER must be used on this type of application. Model 481 and 501 require a flooded suction.

2.0.3 It is highly recommended that all solution tanks be furnished with a low level cut off switch or low level alarm and cut off switch to prevent the pump from running dry. OPERATION AGAINST A DRY SYSTEM WILL CAUSE DAMAGE TO THE PUMP DIAPHRAGM AND REDUCE THE OPERATING LIFE OF THE PUMP.

2.0.4 The single, safest rule of thumb for selecting suction pipe size is to use the same size or one size **larger** than the pump suction connection (1/2" pipe minimum).

### 3.0 DISCHARGE PIPING

3.0.1 It is recommended that the “dia-Pump” operate against a minimum discharge pressure of 50 psig. A back pressure spring is supplied loose with the pump. If 50 psig back pressure is not provided by the application, the back pressure spring should be installed on the pin under the discharge valve cap. Installation of the back pressure spring artificially creates a discharge head. (Refer to Figures II and III.) Note: Spring is permanently installed in Series 500-E.

3.0.2 Take care to use piping suitable for the discharge pressure.

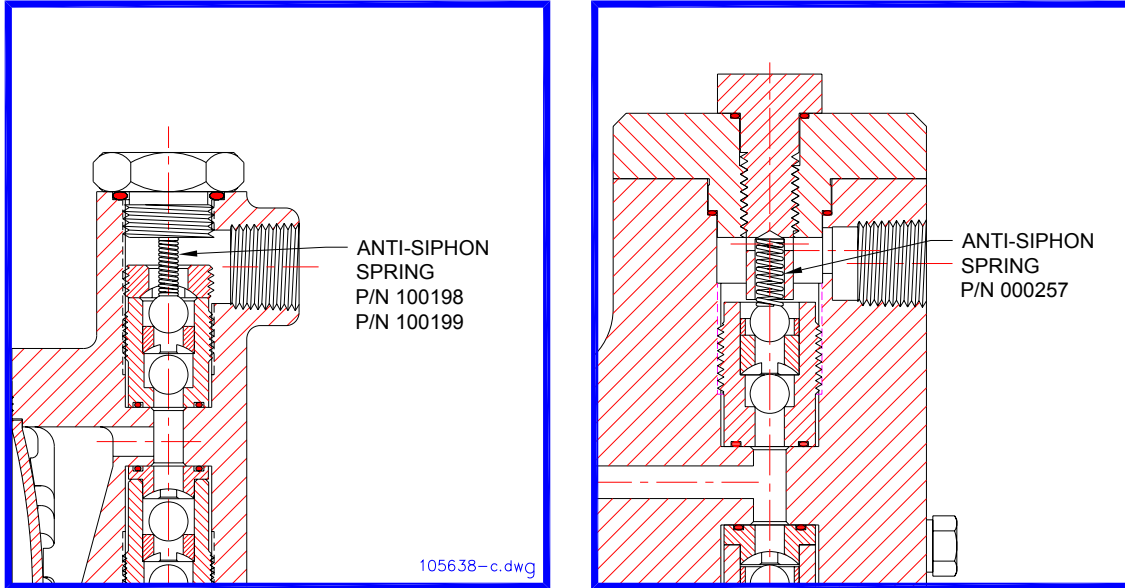

FIGURE II  
IN METAL HEAD PUMP

FIGURE III  
IN PVC HEAD PUMP

### 4.0 ADJUSTMENT OF INTERNAL RELIEF VALVE

4.0.1 All Neptune Series 500 dia-Pumps are supplied with an internal relief valve preset to 200 psi.

<u>MODEL</u>	<u>SETTING</u>
481	200psi
500	200psi
501	200psi
510	200psi
512	200psi
515	200psi
517	200psi
520	200psi
522	200psi
525	200psi
527	200psi
530	200psi
532	200psi
535	200psi
537	200psi
547	200psi

The internal relief valve is designed to protect the pump itself should a discharge pressure beyond the relief valve setting occur.

If a customer order specifies a relief valve setting above those indicated above, the specified setting will be set at the factory. All pumps are tagged with the relief valve setting used by the factory.

4.0.1 (Continued)

To protect the external piping system, it is recommended that a relief valve as manufactured by Neptune Chemical Pump Company, or equal, be placed in the discharge line of the pump. It is further recommended that this relief valve be piped into return of the tank with clear PVC tubing so that it can be determined if the solution is by-passing through the valve and returning to the tank, indicating a line blockage.

Drawing HP-1101 (page 23) illustrates the location of the Internal Relief Valve for Series 500 (FIG. #527 through #530). See drawing 5024 (page 29) for Series 500-A and 500-E.

The drawing shows a passage connecting the hydraulic fluid reservoir with the hydraulic fluid side of the diaphragm.

The passage is interrupted by the Relief Valve Poppet (FIG. #527) which is backed up by a Relief Valve Spring (FIG. #528).

If, during the pump operation, the pressure on the hydraulic fluid side of the pump exceeds the set pressure of the internal relief valve, the poppet is forced from its seat allowing the hydraulic fluid to flow back to the reservoir.

4.0.2 To reset the relief valve to a higher pressure, (the relief valve setting cannot be reduced because of design considerations) instructions are as follows:

4.0.21 Connect a test set-up as shown in Figure IV below.

4.0.22 Start and run the pump until all air is relieved from the discharge liquid (hand valve open).

4.0.23 Remove Relief Valve Plug (Fig.#530).

4.0.24 Close hand valve; pressure gauge will read the internal relief valve setting which should agree with the pressure setting on the tag if the pump is new. The desired setting is 100 psi above the operating pressure of the system into which the pump is injecting. Do not adjust lower than 200 psi.

4.0.25 To change the relief valve pressure setting, use the 3/16' Allen Wrench to adjust spring tension by turning Relief Valve Adjusting Screw (FIG. #529).

- (1) To increase pressure, turn Relief Valve Adjusting Screw (Fig. #529) in.
- (2) To decrease pressure, turn Relief Valve Adjusting Screw (Fig.#529) out.

4.0.26 After resetting or adjusting pressure, replace Relief Valve Plug (Fig. #530).

**CAUTION**

Never turn Relief Valve Adjusting Screw (Fig. #529) completely in.

Do not attempt to set the internal relief valve more than 200psi in excess of name plate rating.

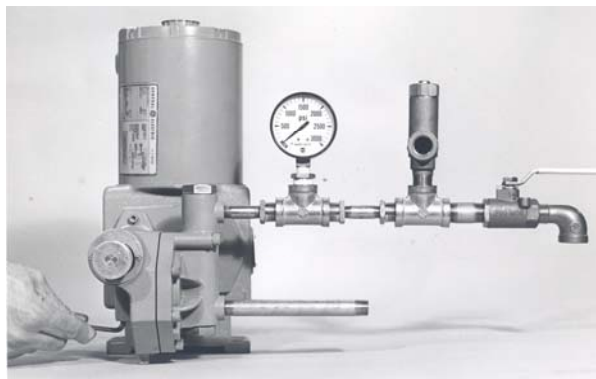

**FIGURE IV**

#### 4.0.3 Parts required to test or adjust Relief Valve Pressure.

1 Pc.	1/4" Pipe Nipple 6" Long
2 Pcs.	1/4" Pipe Nipple 2" Long
1 Pc.	1/4" Hand Valve
2 Pcs.	1/4" Tee
1 Pc.	3/8" NPT 1/2" Hose (Fitting)
1 Pc.	1/2" Hose, As Required
1 Pc.	1/4" Pressure Gauge (Minimum Gauge Pressure 500 psi)
1 Pc.	Allen Wrench 3/16"
1 Pc.	External Relief Valve (optional)

#### NOTE

**The above parts must have a working pressure rating above the required set pressure.**

#### 5.0 INSTALLATION OUTDOORS

The "dia-pump" is a totally enclosed pump which can be used outdoors or indoors. When installed outdoors, make sure that the pump is protected against extremes of nature as follows:

- 5.0.1. Running of the pump when exposed to tropical sunshine, with ambient temperature above 100°F, 38°C would cause excessive oil and motor temperatures. The pump should be shaded and located in such a way as to permit a high degree of air circulation.
- 5.0.2 Under cold conditions, the pump should be insulated and a heater should be supplied in order to maintain the hydraulic fluid at an ambient temperature above 30°F, -1°C. Heat may be provided by a 100 watt bulb or a heater tape, etc.

#### 6.0 START-UP PROCEDURE (FLOODED SUCTION)

The following start-up procedure is complete and does repeat instructions on filling the gear box and pump.

- 6.0.1 The gear box should be filled with hydraulic fluid per the instructions in paragraph 1.0.11. Let the pump stand for 30 minutes and then recheck fluid level. Be certain that pump discharge lines are open.
- 6.0.2 Confirm that the liquid head is flooded and no air remains per the following paragraphs. Pumps should **not** be running. Wear appropriate protective gear when performing any step that involves contact with the chemical.

##### 6.0.2.1 SERIES 500 and 500-A METAL HEAD

Make certain that pumping chamber is flooded and air is purged by loosening Discharge Valve Cap (FIG.#536 on page 21) approximately 2 to 3 turns and allowing solution to appear. Then, tighten discharge valve cap. This procedure will also allow air to vent from pumping chamber. THE "dia-PUMP" WILL NOT FUNCTION IF AIR IS TRAPPED IN THE HYDRAULIC FLUID OR LIQUID PUMP CHAMBERS.

##### 6.0.2.2 SERIES 500 AND 500-A PVC HEAD

PVC Head Pumps –Discharge Valve Cap (P/N 000256 on page 24) is loosened by loosening Valve Cap Screws (P/N 100250).

##### 6.0.2.3 SERIES 500-E (See page 29)

6.0.3 Follow the procedure below:

1. Make certain that the suction line, liquid end and discharge cartridge chamber are filled with water or system fluid.
2. Set the capacity control knob to approximately 30-40% of maximum capacity.
3. On initial start-ups: Check for proper motor rotation (Refer to Paragraph 1.0.9). Run the pump for 10-20 seconds, then stop for 20-30 seconds. Repeat a few times. During these short runs, listen for any abnormal motor or crank noises, and if present, refer to Trouble Shooting Chart.

4. On initial gearbox fill or after replacing hydraulic fluid, run pump for one-half to one hour to warm up oil and allow air bubbles to dissipate. Check discharge line for indication of flow.
5. Once discharge flow is observed proceed to paragraph number 6; if no flow, repeat steps 3 and 4.
6. Increase capacity adjustment setting to 70% of maximum capacity and operate for 10-20 minutes.
7. Reduce capacity adjustment setting to 30-40% of maximum capacity and operate for several minutes, then increase capacity adjustment back to 100% for approximately 10 minutes. Repeat several times to insure that the air is bled from the hydraulic fluid side and the liquid side.

6.0.4 The pump is now ready for “on line” service. Calculate what the desired capacity as a percentage of either the maximum capacity rating on the pump data plate, or the nominal capacity at the required system pressure.

**7.0 START-UP PROCEDURE (SUCTION LIFT) SERIES 500 AND 500-A.**  
 (See page 24 for SERIES 500-E) MODELS 481, 501 AND 510 REQUIRE A FLOODED SUCTION.

7.0.1 If the “dia-Pump” is to be used where suction lift is required, A FOOT VALVE STRAINER MUST BE INSTALLED on the end of the suction line. A pipe tee is installed on the top end of the suction line with one leg to the pump suction, one leg to the suction line and one leg pointing straight up and plugged. Remove plug and fill piping assembly with liquid. Replace plug. Start pump and follow procedure per Paragraph 6.0.3.

Use the following procedure only if required:

7.0.2 Remove Discharge Valve Cap (FIG. #536). Then, using Allen wrench provided, remove Discharge Valve Nut (FIG. #543). The Discharge Valve Nut (FIG. #543) is stamped with the letter “T” to indicate the face which should be installed toward the top on reassembly. Finally, remove Discharge Valve Cartridge (FIG. #539) using special blade provided. Fill the pumping chamber. Replace parts and then follow instructions per Section II, Paragraph 6.0.3. Repeat entire procedure if pump loses prime or runs dry. (See Figures VI and VII.)

**NOTE**

PVC Head Pumps –Remove Discharge Valve Cap (P/N 000256) by removing Valve Cap Screws (P/N 100250). Next, remove Discharge Valve Cartridge (P/N 000259) using special round lug tool provided. Fill pumping chamber. Replace parts and then follow instructions per Section II Paragraph 6.0.3. (Refer to Figure VII.)

**CAUTION**

Do not overtighten PVC valves as the PVC material is not able to withstand excessive force and can fail. Teflon® paste is an excellent thread lubricant and may be applied.

**8.0 START-UP AFTER SUCTION HAS RUN DRY**

In applications where the suction tank does not have a low level cut-off interconnected into the pump motor circuit, the pump may occasionally run dry. THIS MUST BE AVOIDED BECAUSE DAMAGE TO THE PUMP CAN RESULT AND THE SERVICE LIFE WILL BE SIGNIFICANTLY REDUCED WHEN THE PUMP IS ALLOWED TO RUN WITH A DRY LIQUID END.

Before restarting a pump that has run and which has not damaged itself, follow the procedure in Paragraph 6.0 through 6.0.3 of Section II, except it is not necessary to warm up the oil.

®Teflon – A registered trademark of the DuPont Company.

## SECTION III

### NORMAL MAINTENANCE AND DISASSEMBLY INSTRUCTIONS

#### 9.0 MAINTENANCE

Under normal conditions, the “dia-Pump” does not require any significant amount of maintenance. It is advised that periodic visual observations be made of the oil level. See Page 5 for correct oil level. The liquid end of the pump should also be inspected for leakage. These observations should be made regularly, at least every 48 hours.

#### 10.0 REMOVAL OF VALVE CARTRIDGES (See page 27 for SERIES 500-E; Page 30 for 500-V)

The “dia-Pump” incorporates a unique check valve design whereas the discharge and suction piping NEED NOT be disturbed in order to service the valve cartridges.

Should the valves need cleaning, remove as follows:

- 10.0.1 Suction Valve: Remove Suction Valve Cap (FIG. #550) and using Allen Wrench provided, remove Suction Valve Cartridge (FIG. #544).

#### NOTE

PVC Head Pump – Remove Suction Valve Cap (P/N 000256) by removing the Valve Cap Screws (P/N 100250) and remove Suction Valve Cartridge (P/N 000259) using the special round lug tool provided. Caution: PVC is fragile – do not use excessive force.

- 10.0.2 For removal of discharge valve, refer to instruction in Section II, Paragraph 7.0.2.

- 10.0.3 Please refer to Figures VI and VII showing valve cartridge removal.

#### 11.0 CLEANING OF VALVE CARTRIDGES

- 11.0.1 The valve cartridge is a complete and integral unit and should not be disassembled for cleaning. If the valves are found to be worn and in need of replacement, an entire valve cartridge, either suction or discharge, should be ordered. The suction valve is the longer of the two valve cartridges.

- 11.0.2 To clean the valve cartridges, soak in strong detergent and then blow dry with compressed air.

#### 12.0 REPLACING OF VALVE CARTRIDGES (See page 27 for SERIES 500-E)

- 12.0.1 Be certain that the Valve Seat “O” Ring (FIG. #549 for Metal Head Pumps, P/N 100185 for PVC Head Pumps) is removed with the valve and that no other foreign matter is in the valve cavity. Use a small amount of grease to hold the “O” ring in the groove in the end of the valve cartridge on reassembly.

Reverse the procedure used to remove the valve cartridge. Do not over-tighten valve cartridge. Firm tightening is enough to cause the “O” Ring to seal.



FIGURE V  
CUT-AWAY VIEW OF VALVE SECTION, METAL HEAD PUMP



FIGURE VI  
VALVE CARTRIDGE REMOVAL, METAL HEAD PUMP

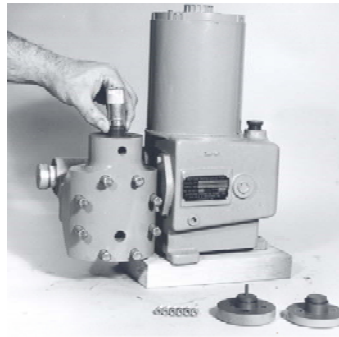

FIGURE VII  
VALVE CARTRIDGE REMOVAL, PVC HEAD PUMP

### 13.0 PROCEDURE FOR REPLACING CONTROL ROD "O" RING (fig. #517) AND SEALING PLATE "O" RING (FIG.#516).

Refer to Figure VIII

1. Remove Drain Plug (FIG. #510) and drain hydraulic fluid.
2. Remove Indicator Plate (FIG. #520) by removing two holding screws.
3. Remove control rod assembly with Control Rod (FIG. #'s 515, 523,524) attached, by turning counter clockwise and pulling out.
4. Insert 11/16" Hex Socket onto the Sealing Nut (FIG. #526) and screw out of pump in a counter clockwise direction. Then, remove Sealing Plate (FIG. #518) using a small brass hook to pull loose.

5. Replace Control Rod "O" Ring (FIG. #517) and Sealing Plate "O" Ring (FIG. #516).
6. Take care when replacing Sealing Plate, (FIG. #518) so as to not damage the Sealing Plate "O" Ring (FIG. #516).
7. Replace all parts and fill pump with hydraulic fluid per previous instructions.
8. Follow start-up procedure as if starting a new pump.

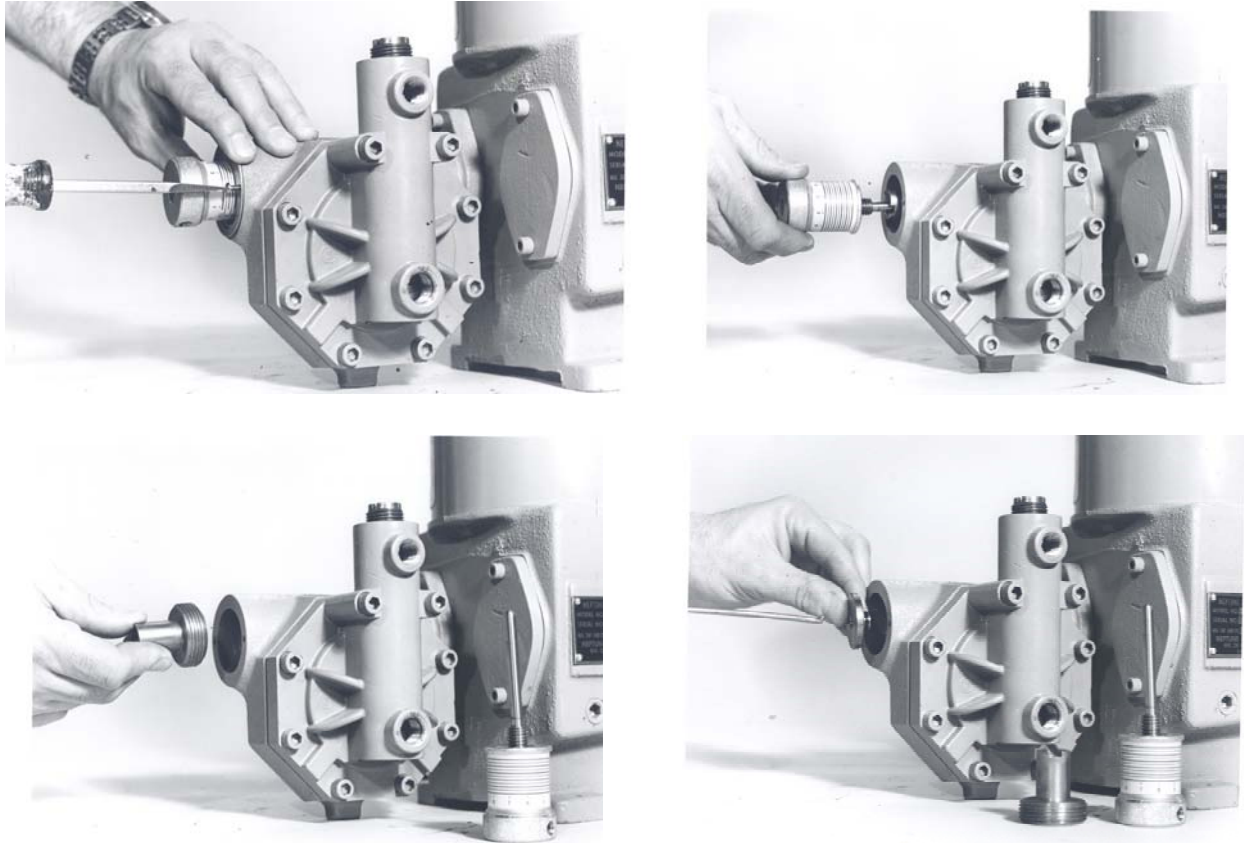

FIGURE VIII  
REMOVAL OF CONTROL ROD ASSEMBLY

#### 14.0 REMOVAL OF PUMP HEAD AND REPLACEMENT OF DIAPHRAGM (REFER TO FIGURES IX AND X)

- 14.0.1 Remove Drain Plug (FIG. #510), and drain hydraulic fluid.
- 14.0.2 Remove Long and Short Pump Head Bolts [(FIG. #'s 551 and 552) or (P/N 101135 and P/N 101136) on PVC pumps.] Lift Pump Head [(FIG. #535) or (P/N 000255, P/N 000258) on PVC pump] away from pump.
- 14.0.3 Remove and examine Teflon Diaphragm (FIG. #533). Remove and examine the Liquid Side Diaphragm Backup Place [(FIG. #532) or (P/N 000254, 100245) on PVC pumps.] Replace with new part, if required. When replacing the Teflon diaphragm, be certain to line it up properly with the sealing grooves.
- 14.0.4 To reassemble, reverse the above procedure. Reassembly is facilitated by laying the pump on its side. Be certain to tighten all bolts evenly. Tighten to 25 ft. lbs. (15ft. lbs. On PVC pump).
- 14.0.5 Start Up Pump by following Start-Up Procedure per Section II Paragraph 1.0.11 and 6.0.3.



FIGURE IX



FIGURE X

15.0 REMOVAL OF MOTOR FROM STANDARD "dia-PUMP" (REFER TO FIGURE XI)

- 15.0.1 Disconnect all wires leading to the motor.
- 15.0.2 Remove Drain Plug (FIG. #510) and drain hydraulic fluid from pump.
- 15.0.3 Remove the fan cover if the motor is a TEFC type. Remove retaining bolts from the top of the motor. These bolts are threaded directly into the Pump Gear Box (FIG. #500).
- 15.0.4 Turn case of motor gently to break silicone seal between motor casing and Pump Gear Box (FIG. #500). Tilt motor slightly forward and remove housing and remove internal part.
- 15.0.5 To replace motor, clean machined surface at top of Gear Box (FIG. #500) and apply silicone sealer. Place motor back in position generally reversing the disassembly procedure.

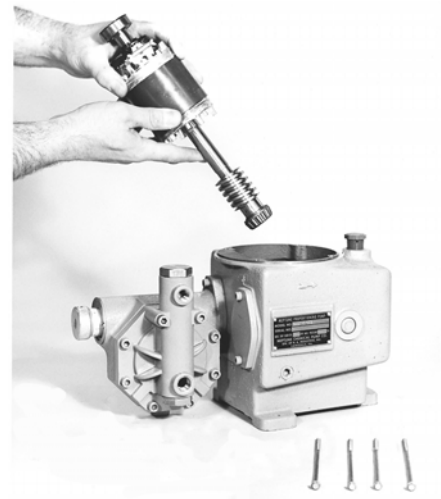
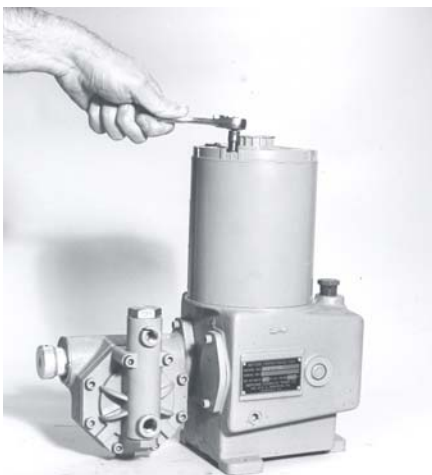

FIGURE XI

## SECTION IV

### MOTOR OPERATING CONDITIONS

- 16.0 The Standard Series 500 “dia-Pump” is supplied with a 1/3 HP or 1/2 HP/single phase/totally enclosed fan cooled motor as an integral part of the pump itself.

The normal temperature rise for this motor is 40°C above ambient temperature and thus, it might appear that the motor is operating at a higher than normal temperature. This situation is normal and should not cause concern.

As a precaution against motor overheating, it is recommended that the pump be located where adequate ventilation is available. It is also highly RECOMMENDED THAT A MOTOR STARTER WITH THE PROPER OVERLOAD PROTECTION BE SUPPLIED AS AN ADDITIONAL SAFETY DEVICE.

The Standard Series 500 “dia-Pump” (1/3HP/1/115V/60C/TEFC) motor is supplied with built-in thermal protection. Automatic overload is provided on all pumps with standard motor with serial numbers higher than 9600-78D.

Should an overload occur on a standard motor unit which is not protected by a motor starter, or on such a unit where the starter has failed, the motor will shut down automatically. It will take approximately ½ hour for the automatic thermal overload switch to reset itself.

## SECTION V TROUBLE SHOOTING CHART

SYMPTOMS	CAUSES	REMEDIES
1. Pump Motor Will Not Operate.	A. Blown Fuse.	A. Check for short circuit or overload.
	B. Open thermal overload device in starter or motor.	B. Reset.
	C. Low liquid level in tank (where low level cut-off is used).	C. Fill tank.
	D. Broken wire.	D. Locate and repair.
	E. Low voltage.	E. Check for too light wiring.
	F. Oil "frozen" in pump.	F. Thaw out.
2. Pump Does Not Deliver Rated Capacity	A. Starved suction.	A. Replace suction piping with larger size, or increase suction head.
	B. Leaky suction piping.	B. Pressure test, repair or replace defective piping.
	C. Excessive suction lift.	C. Rearrange equipment location to reduce suction lift.
	D. Liquid too close to boiling point.	D. Lower temperature or increase suction head pressure.
	E. Air or gas trapped in oil or pumpage.	E. Decrease capacity to 20% for 5 mins., then increase to 100% for 5 mins.
	F. Worn or dirty valves or seats, or both.	F. Clean or replace.
	G. Viscosity of liquid too high (CPS).	G. (1) Reduce viscosity by heating or other means; (2) Increase size of suction piping; (3) Increase suction pressure
	H. Insoluble materials settling out, or crystallization of saturated solution.	H. Check solution strength. Flush and clean solution tank periodically. Suction connection should be 2 to 4" from bottom of solution tank.
	I. Low discharge pressure.	I. A minimum discharge pressure of 50 psi is required to insure proper capacity control.
	J. Capacity adjustment set above 100% capacity mark.	J. Reposition adjustment knob to 100% mark.
	K. Air in hydraulic or chemical systems.	K. Bleed system.

<b>SYMPTOMS</b>	<b>CAUSES</b>	<b>REMEDIES</b>
	L. No foot valve strainer.	L. Install one.
3. Pump delivers erratically.	A. Leaky suction line. B. Worn or dirty valves or seats, or both. C. Excessive excursion of ball from valve seats (indicated by ball chatter). D. Liquid too close to boiling point. E. Leaky internal or external relief valve.	A. Repair or replace piping. B. Clean or replace cartridges. C. Replace cartridges. D. Reduce temperature or raise suction pressure. E. Repair or replace relief valve.
4. Motor Overheats Thermal Overload Activates	A. Overload caused by operating pump beyond rated capacity.	A. Check operating pressure against pump manufacturer's data plate maximum rating.
5. Noisy Operation (1) In Pump	A. Pump Valves.	A. Valves must move to open and close, and they will make a clicking noise as they operate. These noises are sometimes amplified by natural resonances in piping system. They are usually indications of normal valve functioning.
(2) In Gear Reducer	A. Pounding noise at high discharge pressure.	A. Fluid compressibility causes reversal of load on gears at end of pressure stroke. Not considered detrimental.
6. Improper Oil Level in Reservoir.	A. Increases and overflows.	A. Flexible diaphragm punctured by foreign material – replace diaphragm. Clean and flush hydraulic system at once.
7. Pump Delivery is Not Adjustable	A. System pressure too low.	A. Install back-pressure spring, provided, into discharge cartridge. B. Install Back-pressure valve.
8. Pump Does Not Develop Required Pressure	A. Internal relief valve leaking. B. Internal relief valve being actuated.	A. Check setting as per pressure change procedure, Paragraph 4.0. B. System pressure exceeds relief valve set pressure. Refer to Paragraph 4.0 for adjustment procedure.

**SECTION VI**  
**SEE ELECTRIC STROKE CONTROL INSTRUCTION MANUAL**  
**FOR PUMPS FURNISHED WITH OPTIONAL ELECTRIC STROKE CONTROL.**

**SPECIAL INSTRUCTIONS FOR SERIES 500 “dia-Pumps”**  
**WITH PNEUMATIC STROKE CONTROL**

17.0 FUNCTION OF THE PNEUMATIC STROKE CONTROL UNIT

The Neptune pneumatic stroke control unit controls the capacity of the “dia-Pump” over the full operating range. Control is normally effected by an instrument air signal of 3 to 15 psi applied to a Moore Products Model 73N control valve (other air signal parameters also available), which is an integral part of Neptune stroke control unit.

The variation of instrument air signal changes the air pressure on the Diaphragm (FIG. #583) in the control unit, which in turn changes the position of the Pump Capacity Control Rod (FIG. #570).

The position change of the control unit can be observed on a capacity percentage scale seen through the clear plexi-glass shell of the control unit.

The pneumatic control unit may be attached to any standard simplex or duplex Series 500”dia-Pump”.

The operating range of supply air may vary between 40 and 80 psi. The Moore control valve is preset at the factory for a supply air pressure of 60 psi.

The “Pneumatic Stroke Control Unit” is accurately preset and tested at the factory. If the unit does not appear to perform correctly, please contact your local representative or the factory. Do not attempt to adjust the unit in the field without factory advise.

17.0.1 The Moore control valve which is attached to the Neptune actuator supplies a varying air pressure to the Flexible Diaphragm (FIG. #583) which is in turn, balanced by Operating Spring (FIG. #587). The Capacity Control Rod (FIG. #570) is attached to this system.

With the required air signal, the Moore control valve maintains the correct constant air pressure on the Flexible Diaphragm (FIG. #583); i.e. constant position of the Capacity Control Rod (FIG. #570). The springs in the actuator and Moore control valve insure that the controlled position of the diaphragm (i.e. capacity control rod). Supply air and instrument input ports are clearly marked on the Moore Control Valve.

The Moore control valve connections are marked for “Supply Air” and “Instrument Air”. It is important that clean, dry air be furnished to the “Pneumatic Stroke Control Unit”. Cross sectional drawings of the complete unit and the Moore control valve are included with instruction manual.

17.0.2 Maintenance

The Neptune “Pneumatic Stroke Control Unit” is normally maintenance free.

17.0.3 Moore Control Valve

If more complete information is required on the Moore Model 73N control valve, request Moore Bulletin #SD73-5 in writing from Neptune.

**MODEL/SPEED/SIZE CHART**

STROKING SPEED						
PISTON SIZE	18 SPM	37SPM	72 SPM	117SPM	144 SMP	175 SPM
½”	501	500/510	512	515	517	
11/16”		520	522	525	527	
1-1/16”		530	532	535	537	538
1-3/16”					547	

**SECTION VII PARTS LIST  
SERIES 500 AND 500-A PUMP PARTS**

FIG. NO.	DESCRIPTION	QTY.	PART NO.
500	Gear Box*	1	000162
501	Worm Gear 18 SPM*	1	003517
	Worm Gear 37 SPM*	1	000164
	Worm Gear 72 SPM*	1	000166
	Worm Gear 117 SPM*	1	000163
	Worm Gear 144 SPM*	1	002818
	Worm Gear 175 SPM*	1	000165
502	Connecting Rod	1	000167
503	Gear Shaft*	1	106305
506	Worm 18 SPM	1	003516
	Worm 37 SPM	1	000170
	Worm 72 SPM	1	000172
	Worm 117 SPM	1	000169
	Worm 144 SPM	1	002817
	Worm 175 SPM	1	000171
507	Bearing Cup	1	100179
508	Bearing Cone	1	100180
509	Worm Spring Pin	1	100181
510	Drain Plug	1	100182
511	Connecting Rod Pin	1	100183
512	Fill Plug	1	000191
513	Pump Body, Right Hand		
	1/2" Small Cavity††	1	000180
	1/2" Standard Cavity††	1	000178
	11/16" Standard Cavity††	1	000177
	1-1/16" Standard Cavity††	1	000176
	1-3/16" Standard Cavity††	1	003232
	Pump Body, Left Hand		
	1/2" Small Cavity††	1	000179
	1/2" Standard Cavity††	1	000175
	11/16" Standard Cavity††	1	000174
	1-1/16" Standard Cavity††	1	000173
	1-3/16" Standard Cavity††	1	003235
514	Piston 1/2"	1	000181
	Piston 11/16"	1	000182
	Piston 1-1/16"	1	000183
	Piston 1-3/16"	1	003234
515	Control Rod	1	000184
516	Sealing Plate O-Ring 1/2"	1	100184
	Sealing Plate O-Ring 11/16"	1	100185
	Sealing Plate O-Ring 1-1/16"	1	100186
	Sealing Plate O-Ring 1-3/16"	1	100244
517	Control Rod O-Ring	1	100188
518	Sealing Plate 1/2"	1	000185
	Sealing Plate 11/16"	1	000186
	Sealing Plate 1-1/16"	1	000187
	Sealing Plate 1-3/16"	1	003233

FIG. NO.	DESCRIPTION	QTY.	PART NO.
519	Control Rod Spring Pin	1	100189
520	Indicator Plate	1	000188
521	Indicator Plate Screws	2	100190
522	Control Knob Set Screw	1	100191
523	Control Rod Positioner	1	000189
524	Control Knob	1	002071
526	Sealing Nut	1	002069
527	Relief Valve Poppet Except Model 547	1	000193
	Relief Valve Poppet Model 547 Only	1	003531
528	Relief Valve Spring Except Model 547	1	100193
	Relief Valve Spring Model 547 Only	1	107948
	Relief Valve Spring-High Pressure Denoted by "HP" in Model No. After Material Code-Example: 515-S-N3HP	1	106319
529	Relief Valve Adjusting Screw	1	105164
530	Relief Valve Plug	1	100196
531	Oil Side Backup Plate		
	Small Diameter Models 481, 500, 501††	1	000197
	Standard Diameter Except Models 53X and 54X††	1	000194
	Standard Diameter Models 53X and 54X††	1	003946
533	Teflon Diaphragm		
	Small Cavity ††	1	000231
	Standard Cavity ††	1	000200
534	Pump Body Cap Screws	2	100197
358	Valve Cap O-Rings	2	100200
	Valve Cap O-Rings-Teflon	2	100213
549	Valve Seat O-Rings	2	100204
	Valve Seat O-Rings-Teflon	2	100203
553	Pipe Plug	1	100210
554	Cover Plate	1	000229
555	Cover Plate Screws	2	100211
556	Std. Motor Assembly 18 SPM	1	003618
	Std. Motor Assembly 37 SPM**	1	002400
	Std. Motor Assembly 72 SPM**	1	002401
	Std. Motor Assembly 117 SPM**	1	002402
	Std. Motor Assembly 144 SPM**	1	002836
	Std. Motor Assembly 175 SPM**	1	002407
557	Hydraulic Fluid (2 qts.) ISO68	1	003089
	Hydraulic Fluid (2 qts.) SAE90	1	002372
590	Gasket or Sealer	1	106290
591	Gasket or Sealer	2	106291
5002	Shaft Retainer Assembly*	1	002722
5004	Thrust Washers	3-4	100252
5025	Shaft Retainer Screws	3	100254
5699	Knob Friction O-Ring	1	100417

STD motor assemblies include figure numbers 506, 508, 509.

††Models 481, 500 and 501 are small cavity. All others are standard cavity.

Right hand pump body is standard on all Simplex Pumps.

\* Items not to be used on 500-A pumps (page 2)

\*\* Includes Part Nos. 506, 508 and 509.

1/3-1-115-60-TEFC-CAP-48Y.

**PARTS FOR PUMP WITH METAL HEADS**

FIG NO.	DESCRIPTION	QTY.	N1 PART NO.	N3 PART NO.	N4 PART NO.
532	Diaphragm Back Up Plate Liquid Side (Standard Cavity)	1	000195	000195	000196
	Diaphragm Back Up Plate Liquid Side (Small Cavity)	1	000198	000198	000199
535	Liquid Head (Standard Cavity)	1	000201	000202	000203
	Liquid Head (Small Cavity)	1	000204	000205	000206
536	Discharge Valve Cap	1	002073	002073	002072
537	Anti-Siphon Spring 18, 37, 72 or 117 SPM Pumps	1	100198	100198	100199
539	Discharge Valve Cartridge	1	000209	000209	000210
543	Discharge Valve Nut	1	000215	000215	000216
544	Suction Valve Cartridge	1	000217	000217	000218
550	Suction Valve Cap	1	000207	000207	000208
551	Short Pump Head Bolts	6	100205	100206	100206
552	Long Pump Head Bolts	2	100207	100208	100208

**SPARE PARTS KIT (N1 AND N3 CONSTRUCTION) MODELS 500 THROUGH 547**

<b>FIG. NO.</b>	<b>DESCRIPTION</b>	<b>QTY.</b>	<b>PART NUMBER</b>	
539	Discharge Valve Cartridge	1	000209	<b>KIT NUMBER 002712</b>
544	Suction Valve Cartridge	1	000217	
549	Valve Seat O-Ring	4	100204	
538	Valve Cap O-Ring	4	100200	
533	Diaphragm (Models 500 & 501 Only)	1	000231	
533	Diaphragm (All Other Models)	1	000200	
517	Control Rod O-Ring	2	100188	
516	Sealing Plate O-Ring (Models 500/501/510/515)	2	100184	
516	Sealing Plate O-Ring (Models 520/522/525/527)	2	100185	
516	Sealing Plate O-Ring (Models 530/532/535/537/538)	2	100186	
516	Sealing Plate O-Ring (Models 547)	2	100244	

**SPARE PARTS KIT (N4 CONSTRUCTION) MODELS 500 THROUGH 547**

<b>FIG. NO.</b>	<b>DESCRIPTION</b>	<b>QTY.</b>	<b>PART NUMBER</b>	
539	Discharge Valve Cartridge	1	000210	<b>KIT NUMBER 002713</b>
544	Suction Valve Cartridge	1	000218	
549	Valve Seat O-Ring	4	100204	
538	Valve Cap O-Ring	4	100200	
533	Diaphragm (Models 500 & 501 Only)	1	000231	
533	Diaphragm (All Other Models)	1	000200	
517	Control Rod O-Ring	2	100188	
516	Sealing Plate O-Ring (Models 500/501/510/515)	2	100184	
516	Sealing Plate O-Ring (Models 520/522/525/527)	2	100185	
516	Sealing Plate O-Ring (Models 530/532/535/537/538)	2	100186	
516	Sealing Plate O-Ring (Models 547)	2	100244	

**SPARE PARTS KIT (N5 CONSTRUCTION) MODELS 500 THROUGH 547**

<b>FIG. NO.</b>	<b>DESCRIPTION</b>	<b>QTY.</b>	<b>PART NUMBER</b>	
P-539-C	Discharge Valve Cartridge	1	000259	<b>KIT NUMBER 002714</b>
P-544-C	Suction Valve Cartridge	1	000262	
P-549-C	Valve Seat O-Ring	4	100185	
P-538-C	Valve Cap O-Ring	4	100244	
533	Diaphragm (Models 500 & 501 Only)	1	000231	
533	Diaphragm (All Other Models)	1	000200	
517	Control Rod O-Ring	2	100188	
516	Sealing Plate O-Ring (Models 500/501/510/515)	2	100184	
516	Sealing Plate O-Ring (Models 520/522/525/527)	2	100185	
516	Sealing Plate O-Ring (Models 530/532/535/537/538)	2	100186	
516	Sealing Plate O-Ring (Models 547)	2	100244	

**PARTS FOR PUMPS WITH MOTOR FLANGE ADAPTER, (REFER TO PARTS DRAWING 000911 ON PAGE 25)**

<b>FIG. NO.</b>	<b>DESCRIPTION</b>	<b>QTY.</b>	<b>PART NUMBER</b>
507	Bearing Cup	1	100179
508	Bearing Cone	2	100180
558	Motor Flange Adapter	1	000227
559	Worm Shaft with Retaining Ring attached (Part #107592)	1	100228
560	Lovejoy Coupling	1	100053
561	Oil Seal	1	100214
562	Adapter to Gear Box Bolts	4	100215
563	Adapter to Motor Bolts	4	100216
564	Lock Washer	4	100217
565	Coupling Key	2	100218
566	Lock Washers	4	100219
509	Spring Pin	1	100181

**PARTS UNIQUE TO PUMPS SUPPLIED WITH NEPTUNE PNEUMATIC STROKE CONTROL**

<b>FIG. NO.</b>	<b>DESCRIPTION</b>	<b>QTY.</b>	<b>PART NUMBER</b>
570	Control Rod "P"	1	000273
571	Control Mount	1	000274
572	Short Mounting Bolt	3	100259
573	Plexiglass Shell	1	000275
576	Piston	1	000276
578	Range Spring, 3-15 psi (9 psi Span) Standard	1	100260
578	Range Spring, 3-9 or 9-15 psi (6 psi Span)	1	100261
578	Range Spring, 5-25 psi (20 psi Span)	1	100262
578	Range Spring, 3-27 psi (24 psi Span)	1	100263
579	Housing	1	000277
580A	Moore 73N Control Valve – Forward Acting	1	100265
580B	Moore 73N Control Valve – Reverse Acting	1	100266
581	Retainer Bolt	1	100267
583	Pneumatic Diaphragm	1	100268
584	Control Rod Adapter	1	000280
585	Control Spring Pin	1	100269
586	Long Mounting Bolt	3	100270
587	Operating Spring	1	100271
589	Retaining Plate and Stop Bushing	1	000281

**PARTS UNIQUE TO PUMPS SUPPLIED WITH "FALP" (REFER TO PARTS DRAWING FALP ONPAGE 25)**

<b>FIG. NO.</b>	<b>DESCRIPTION</b>	<b>QTY.</b>	<b>PART NUMBER</b>
562	Adapter to Gearbox Bolts	4	
563	Adapter to Motor Bolts	4	100216
564	Lock Washers	4	100217
566	Lock Washers	4	100219
	Motor Flange Adapter	1	004157
	Motor Worm Shaft	1	004156
	Wave Spring	1	107599
	Bearing	1	106180
	Retaining Ring	1	106593

**SECTION VII  
PARTS ORDERING INSTRUCTIONS**

Note: For Prompt entry of parts orders; your order must include both model number and serial number.

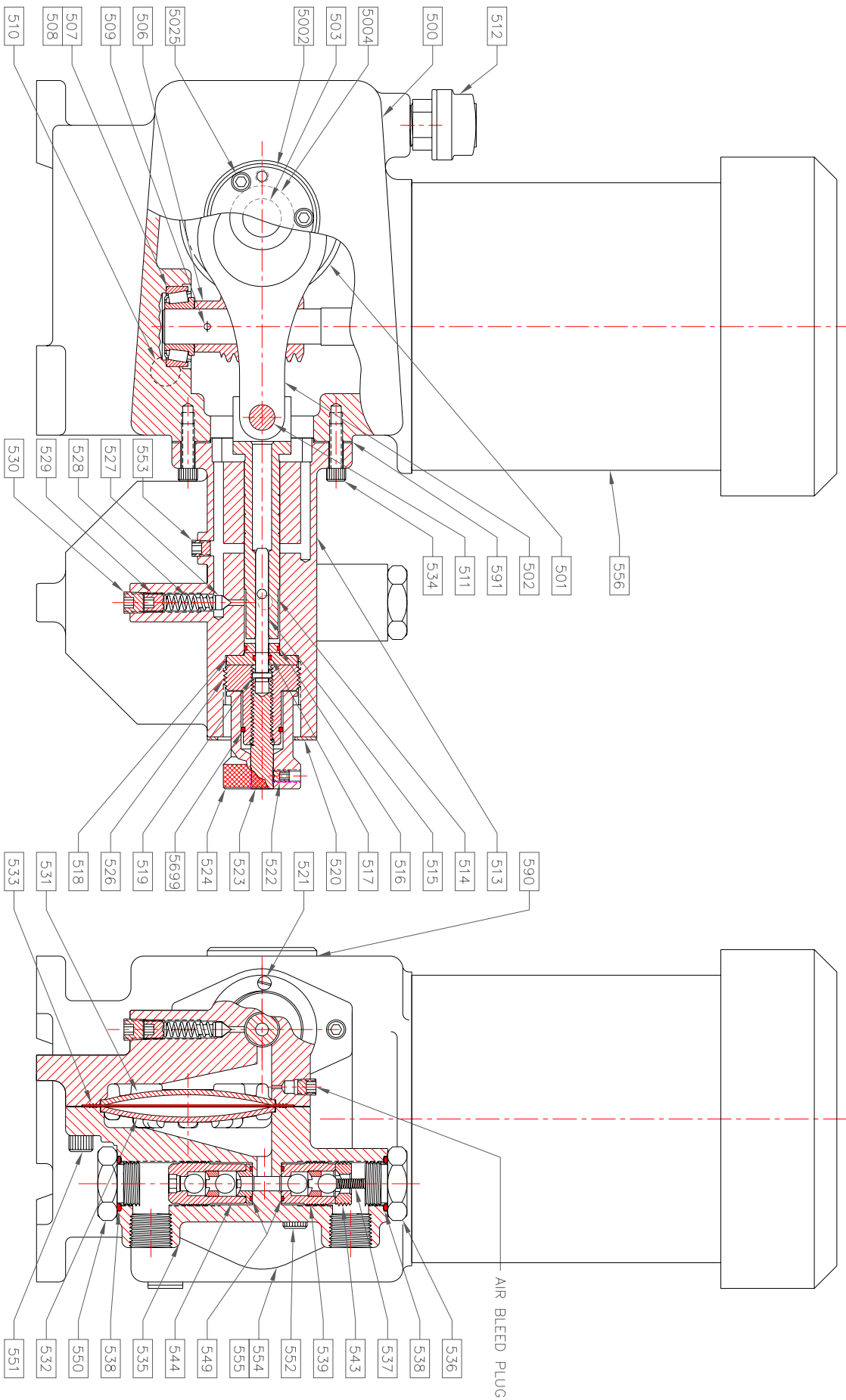

Drawing HP-1102

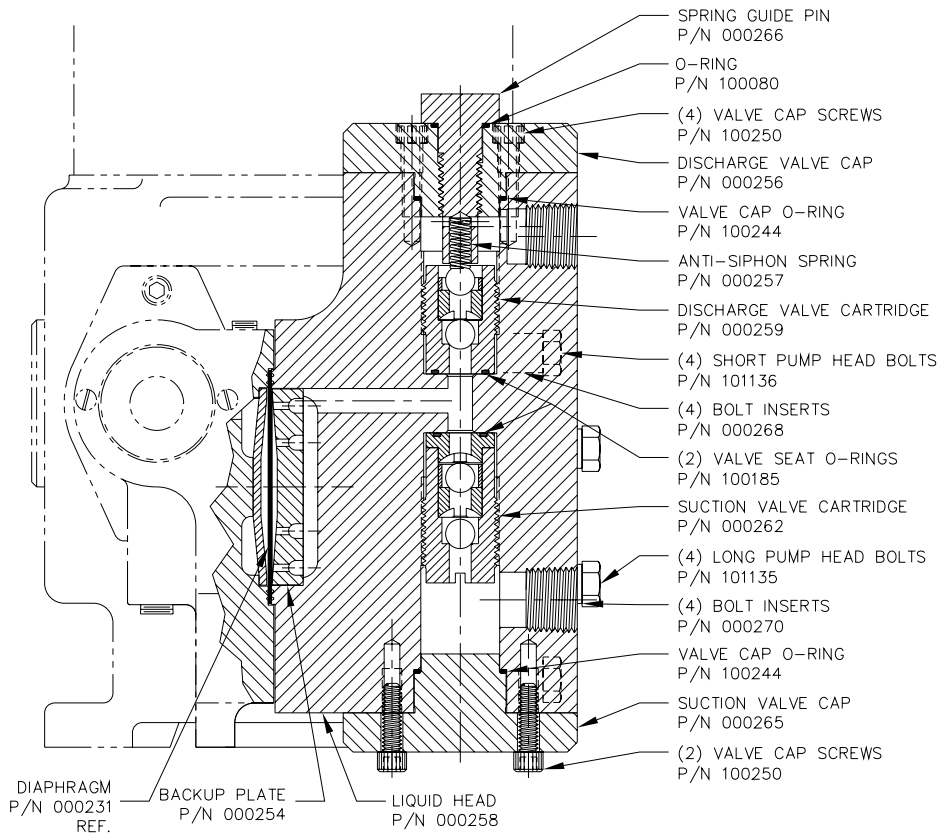

**SERIES 500 PVC HEAD ASSEMBLY WITH SMALL CAVITY  
(ASSEMBLY P/N 002074)**

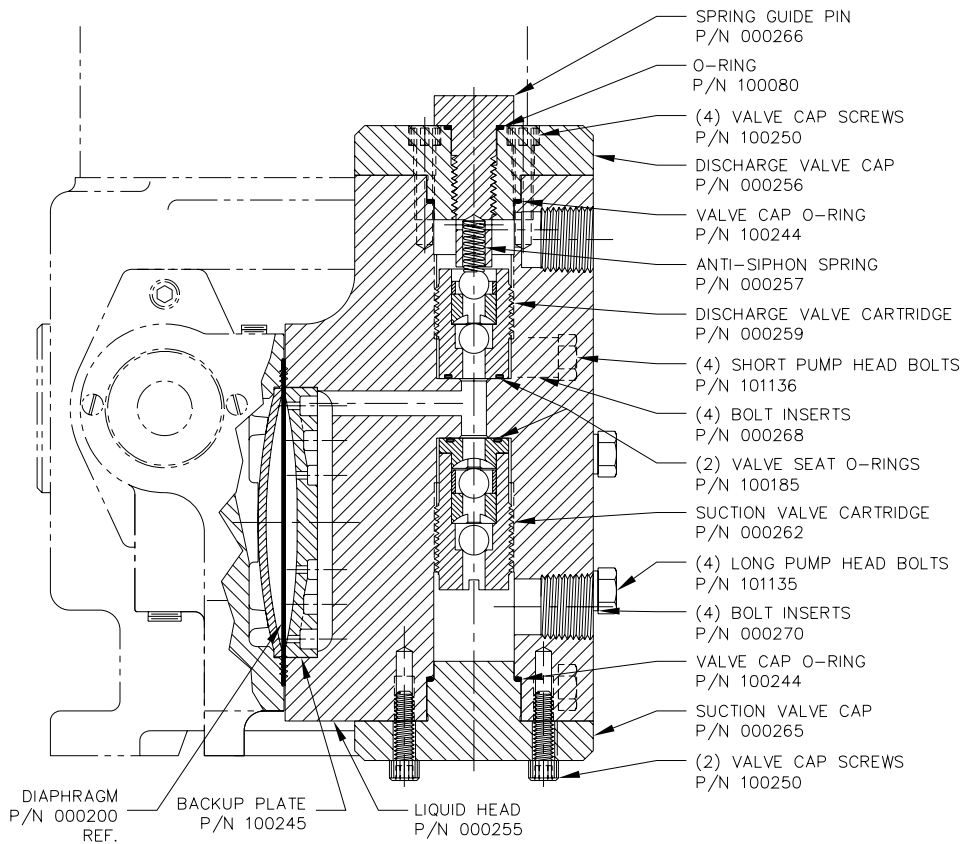

**SERIES 500 PVC HEAD ASSEMBLY WITH STANDARD CAVITY  
(ASSEMBLY P/N 002075)**

Kvnr liquid end material code IN81 is available in the style used for Series 500-F only. See Page 27.

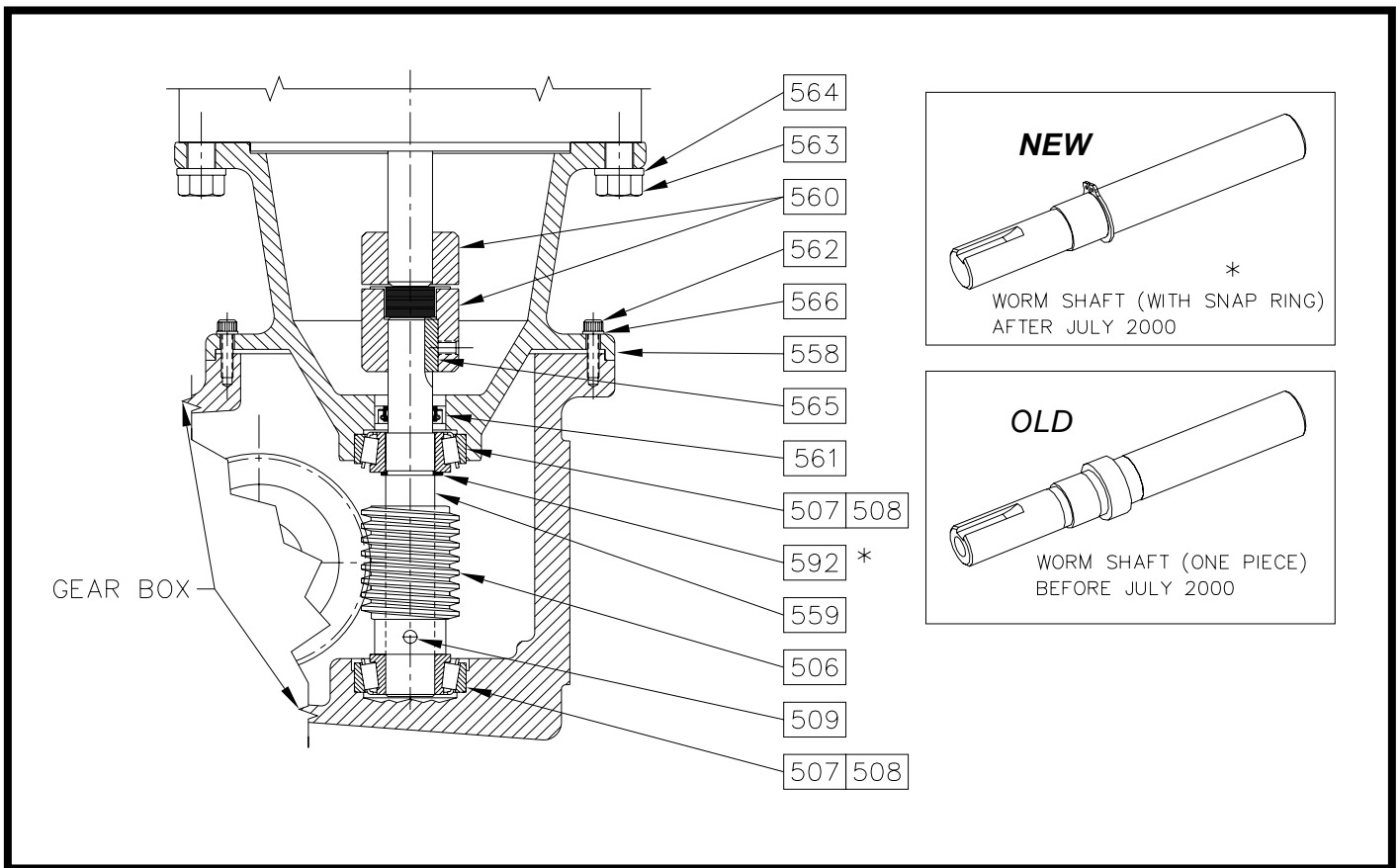

DRAWING #000911

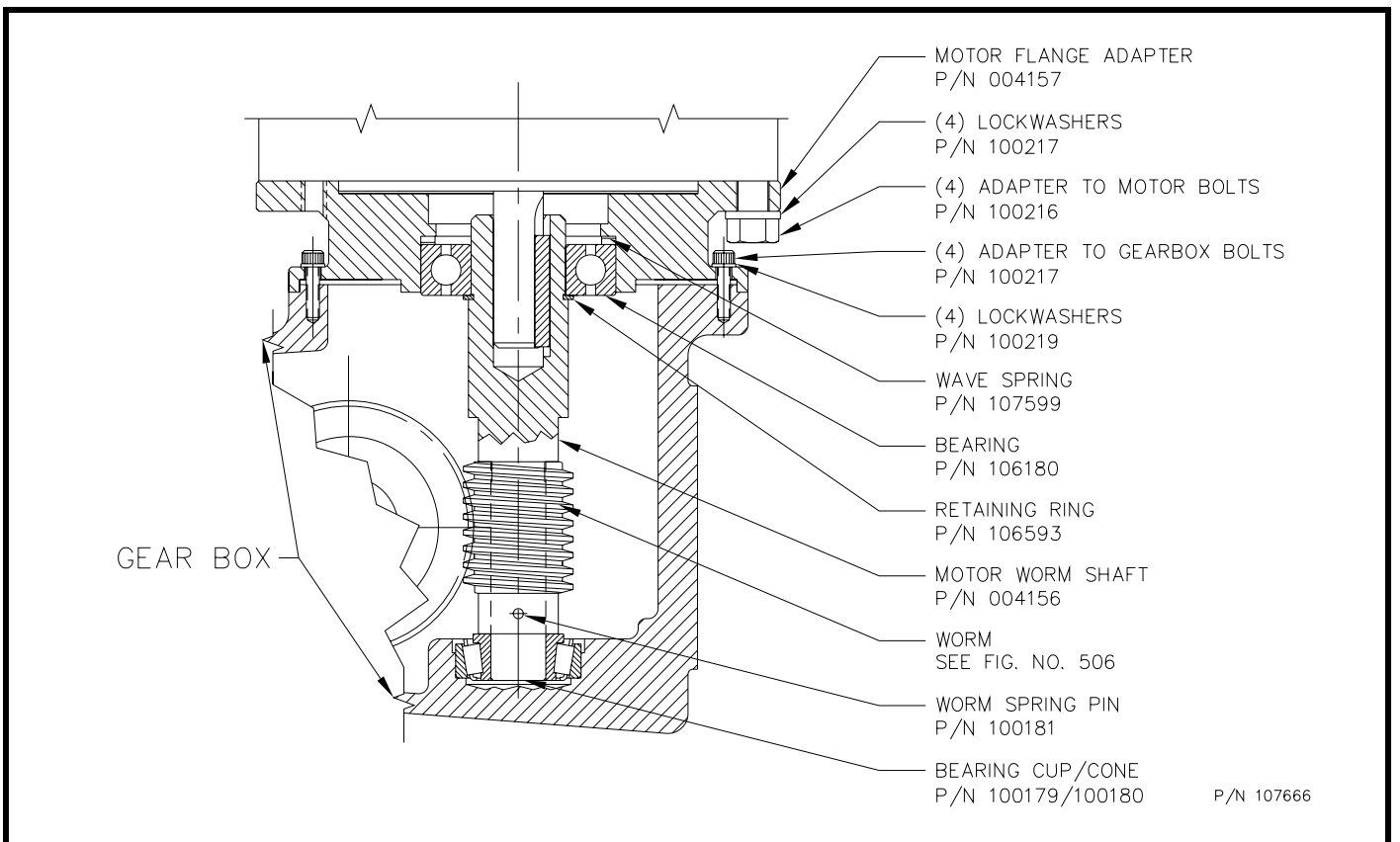

DRAWING # FALP

Addendum to Operating and Instruction Manual for the 500 dia-pump and 500-A dia-pump

This sheet describes the differences in liquid head design of the Series 500-E-AR “dia-pump”. This sheet is intended to be used with the Operating and Instruction Manual for Neptune Series 500 and 500-A “Dia-Pumps”.

The Series 500-E-AR Pumps are identical to the Series 500-A except for an economy liquid head. All parts of the instruction manual relating to Series 500-A are applicable to 500-E except for liquid head parts and valve instructions. The 500-E-AR consists of: (1) liquid head casting, (1) suction valve (P/N: 004498), (1) discharge valve (P/N: 004503) and (1) air release valve (P/N: 104412).

Installation: Refer to installation instructions of the 500, 500-A and 500 E for proper set up of pump. The unique design of the "AR" liquid head allows you to vent off gases that may accumulate in the pump head from the air release valve (P/N: 104412). You must connect tubing (3/16 ID X 5/16 OD) to the connection on the air release valve and return it back to the supply tank or drain.

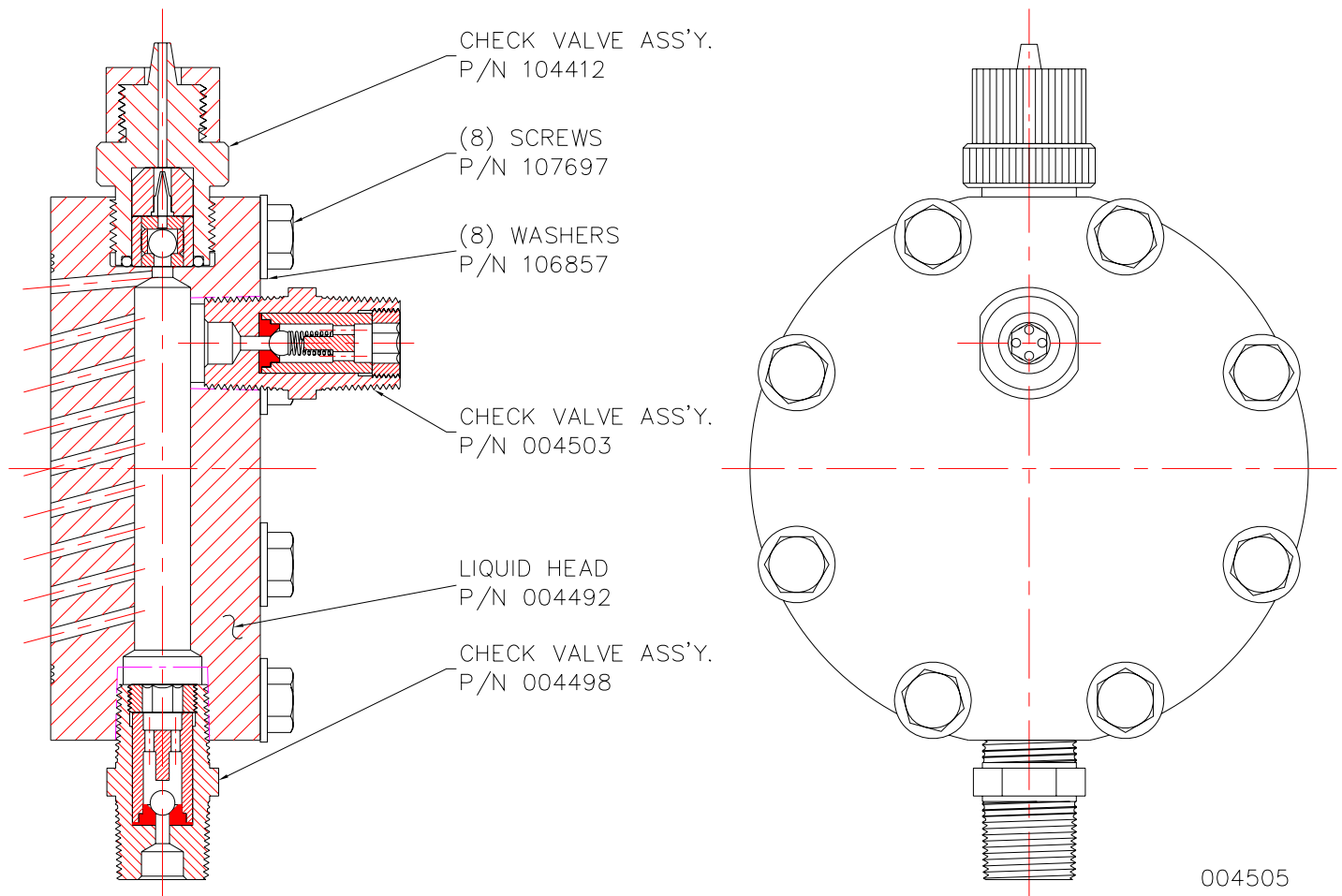

004586---- Complete Spare Parts Kit\*

\*Includes suction and discharge valve cartridges, diaphragm and all o-rings.

Addendum to Operating and Instruction Manual for the 500 dia-pump and 500-A dia-pump

This sheet describes the differences in liquid head design of the Series 500-E “dia-pump”. This sheet is intended to be used with the Operating and Instruction Manual for Neptune Series 500 and 500-A “Dia-Pumps”.

The Series 500-E Pumps are identical to the Series 500-A except for an economy liquid head. All parts of the instruction manual relating to Series 500-A are applicable to 500-E except for liquid head parts and valve instructions. The 500-E liquid head consists of: (1) liquid head casting, (1) back-up plate (on metal head models only), and (2) valve cartridges. The valve cartridges are replaced as a unit; they cannot be disassembled.

The following parts are unique to Series 500-E Models:

DESCRIPTION	QTY	CODE N1 CAST IRON Part #	CODE N3 316SS Part #	CODE N5 PVC Part 3	CODE N8 KYNAR Part 3
Pump Head	1	003277	003276	003278	003326
Valve Cartridge Suction	1	003321	003321	003279	003322
Back-Up Plate	1	000195	000195	NA	NA
Valve Cartridge Discharge	1	003321	003321	003279	003332
Complete Spare Parts Kit*	1	003385	003385	003386	003387

\*Includes suction and discharge valve cartridges, diaphragm and all o-rings.

**NOTE: PRIMING PROCEDURE**

Series 500-E pumps have no anti-siphon spring to defeat when priming, they also do not have a valve cap to vent and bleed air. To bleed air on initial start-up it will be necessary to open a valve to the atmosphere in the discharge line before the first isolation valve. If there is no valve in the particular installation, then breaking the piping connection at tubing joint or union will allow the air to escape while the pump is primed. This is only required when first starting a new installation. Since there is no anti-siphon spring, it is necessary to install a backpressure valve in the line when pumping to atmospheric or low-pressure injection points.

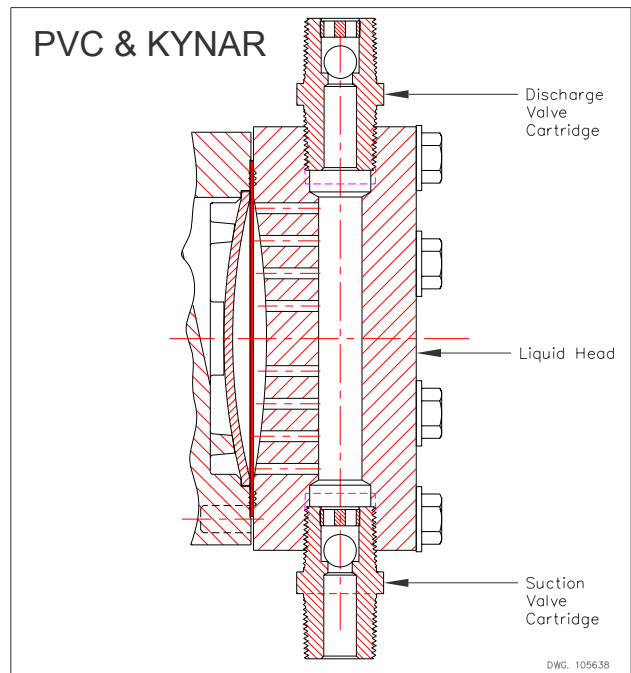
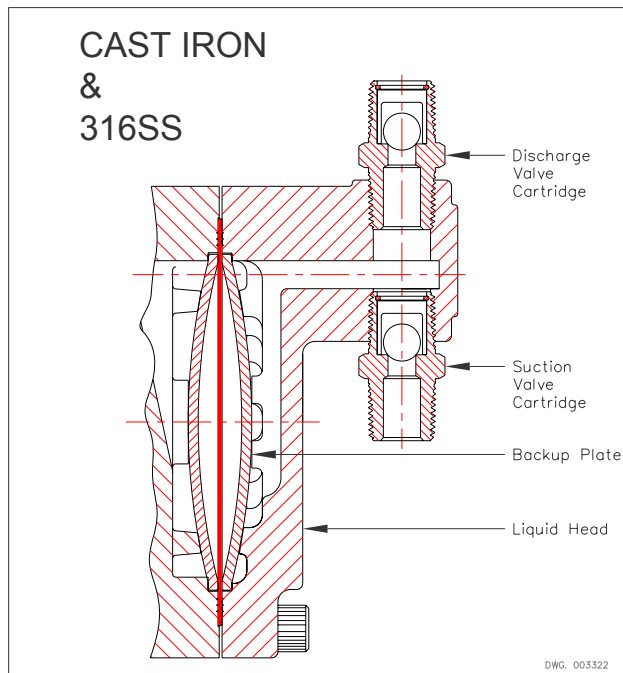

Valve cartridges remove as one piece. Apply pipe dope or Teflon paste to threads to reinstall.

**THE FOLLOWING CHANGES IN TEST MUST BE CONSIDERED WHEN USING THIS MANUAL FOR THE SERIES 500-A “dia-PUMP”. EXCEPT FOR THE DIFFERENCES LISTED BELOW, THIS INSTRUCTION MANUAL APPLIES COMPLETELY TO BOTH THE SERIES 500 AND SERIES 500-A “dia-PUMP”.**

<b>PAGE</b>	<b>SECTION</b>	<b>PARAGRAPH</b>	
7	4.0.1	2	Drawing number 5024 illustrates the location of the internal relief valve (FIG. #527 thru #530).
7	4.0.21		Location of 500-A “dia-PUMP” Internal Relief Valve is on top of the Pump Body, not as shown in Figure IV.
13	15.0.3		Remove retaining bolts ... (FIG. #5016, 5018, 5019, 5020)
13	15.0.4		Turn Case ... (FIG. #5016, 5018, 5019, 5020)
13	15.0.5		To replace motor ... (FIG. #5016, 5018, 5019, 5020)
20	18.0.6		Parts for Series 500-A “dia-PUMP” not common to Series 500 “dia-PUMP”.

<b>FIG. NO.</b>	<b>DESCRIPTION</b>	<b>QTY.</b>	<b>PART NUMBER</b>
5002	Shaft Retainer Assembly	1	000242
5003	Gear Shaft	1	100251
5005	Worm Gear 37 SPM	1	000292
5006	Worm Gear 72 SPM	1	000293
5007	Worm Gear 117 SPM	1	000291
5008	Worm Gear 175 SPM	1	000294
5016	Gear Box (Model 500 Only)	1	000288
5018	Gear Box (Model 510/515 Only)	1	000282
5019	Gear Box (Model 520/522/525 Only)	1	000283
5020	Gear Box (Model 530/532/535/538 Only)	1	000284

**RECOMMENDED SPARE PARTS**

**The Spare Parts Kits listed on page 21 of this manual comprise the recommended spare parts for all Series 500 dia-PUMPS.**

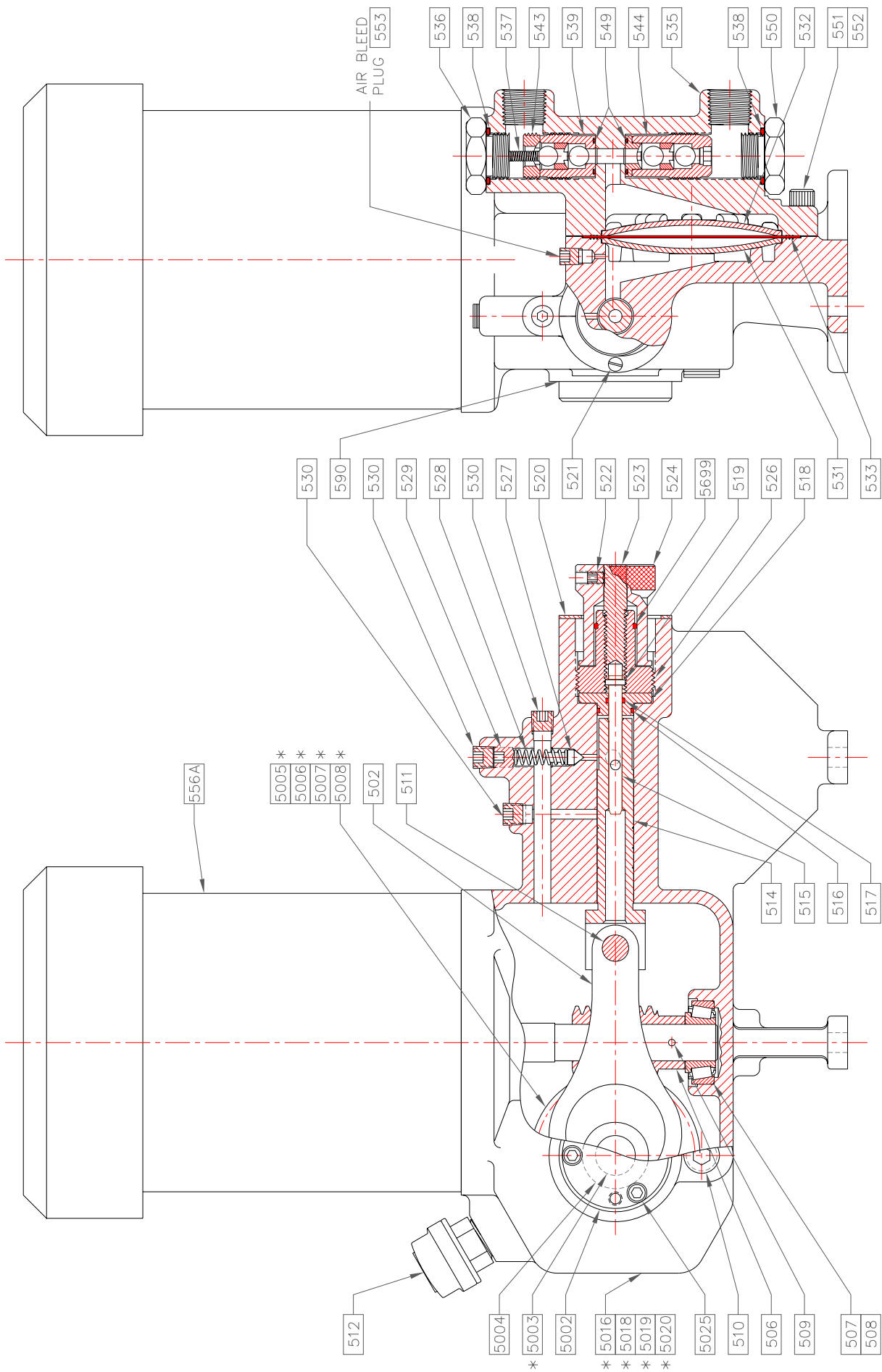

**Drawing 5024**

**INTRODUCTION**

The Neptune Series 500 “dia-Pump” is available with a special liquid end to handle higher viscosity liquids. Model numbers of pumps are for example 515-VS-N3 or 535-VS-N3.

This liquid end, which is only available in 316SS, is different than the standard liquid end as the suction valve, back up plate, and liquid head are modified to allow oversized porting to enable thick liquids to be drawn into the pump on the suction stroke. All other parts of the pump are identical to the standard pump.

Note, the suction connection is directly up from below and the normal suction connection is plugged. The pump must be elevated as the inlet connection is plugged. The pump must be elevated as the inlet connection extends below the plane of the gear box seat.

Maintenance instructions are identical to the standard pump. The four parts which are different from the standard unit are shown below.

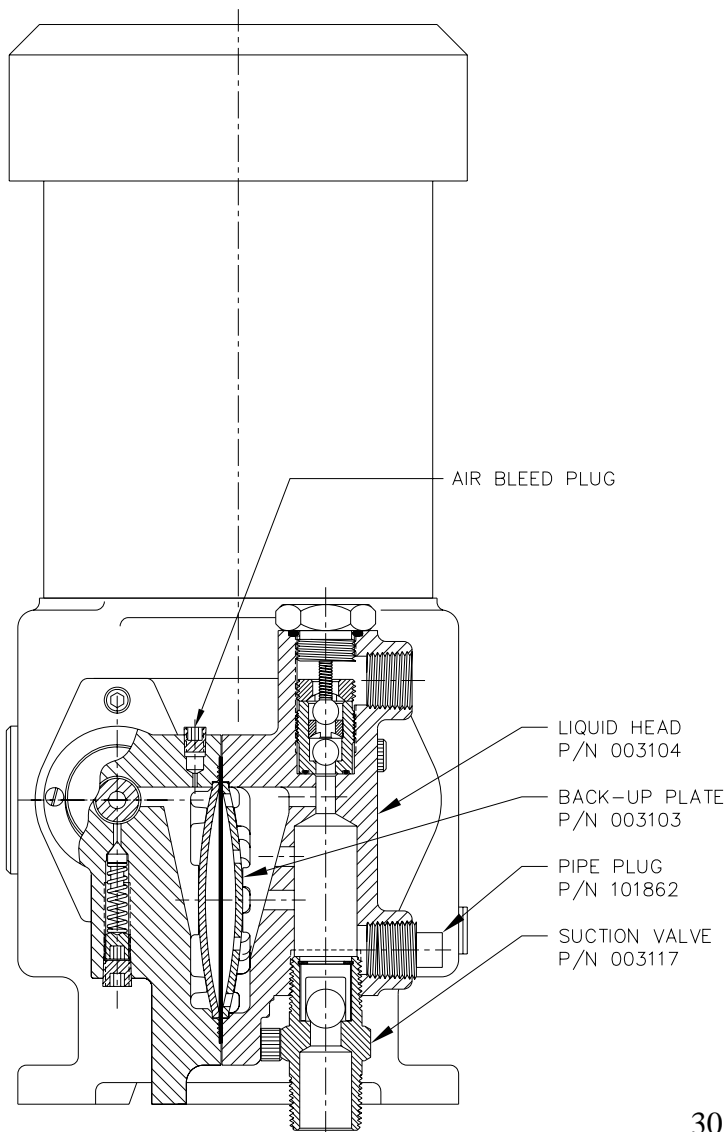

**Series 500V (High Viscosity)  
Head Parts Drawing  
C-003105**

**INTRODUCTION**

A special version of the Neptune Series 500 Pump is the Model 481. This pump is different than the standard pump due to the unique Low-Flow design, which involves a smaller Piston and Metering Device with extremely close tolerances. (Correct installation is critical for proper pump operation.) The valves used in this pump also contain smaller ball checks and seats. Refer to Parts Drawing S00091 for cross-sectional details. This drawing also indicates each part of the Model 481 that is not common to the other pumps within the Series 500.

Generally, the maintenance and repair procedures for the Model 481 are the same as those shown in the Operating and Instruction Manual for the Series 500 and 500-A Pumps. Failure to follow these instructions could cause pump output to become erratic, or stop altogether.

**PUMP CALIBRATION**

Each pump is tested at the factory prior to shipment to assure proper operation without leakage at the maximum capacity and discharge pressure specified, with a constant flooded suction of 2 feet of water. For precise capacity control in the field, a calibration test under actual operating conditions with the actual piping arrangements is frequently desirable. Use a calibration drawdown cylinder in the suction line.

After the suction and discharge lines are piped with a convenient sampling point in the suction line, and the pump has been suitably primed, test samples are collected at 25%, 50% 75% and 100% capacity settings. A straight line results when these points are plotted on graph paper. This graph can be used as a calibration curve for an intermediate setting as long as suction and discharge conditions remain constant.

It is important to realize that the sample at 50% will not necessarily be 1/2 that of 100%, nor will any other sample points be to a specific percentage of the 100% value, but the pump will give repetitive samples at the same setting. This is due to the extremely low volume of the pump which results in a shifting zero flow point as pressure increases and can be seen in the curve below.

**RECOMMENDED SPARE PARTS**

- 1. Diaphragm, P/N 000231, Qty. – (1)
- 2. “O” Ring, P/N 106997, Qty. – (1)
- 3. “O” Ring, P/N 105079, Qty. – (1)
- 4. “O” Ring, P/N 100204, Qty. – (2)
- 5. “O” Ring, P/N 100200, Qty. - (2)
- 6. Suction Valve, P/N 002439, Qty. – (1)
- 7. Discharge Valve, P/N 002440, Qty. – (1)

Spare Parts Kit P/N 003624 contains all parts Above in the quantity shown.

**THIS MODEL MUST BE INSTALLED WITH FLOODED SUCTION.**

The hydraulic fluid for “481” Pump supplied by Neptune is EP SAE 90. Common sources for hydraulic fluid are listed on page 5.

**PARTS ORDERING INSTRUCTIONS**

**Note: For prompt entry of parts orders; your order must include both model numbers and serial number.**

**PERFORMANCE CURVE**

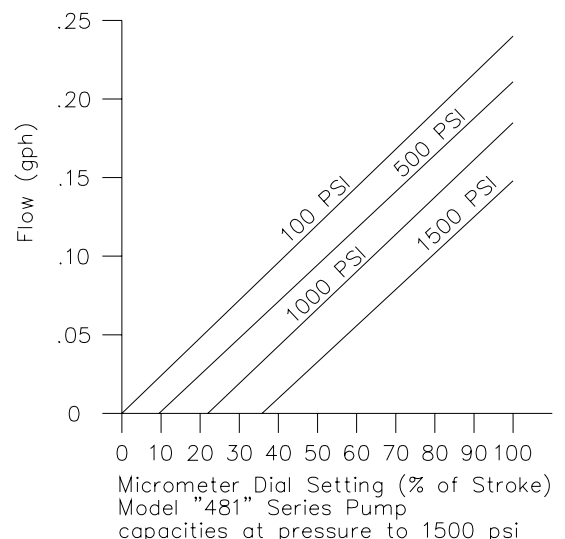

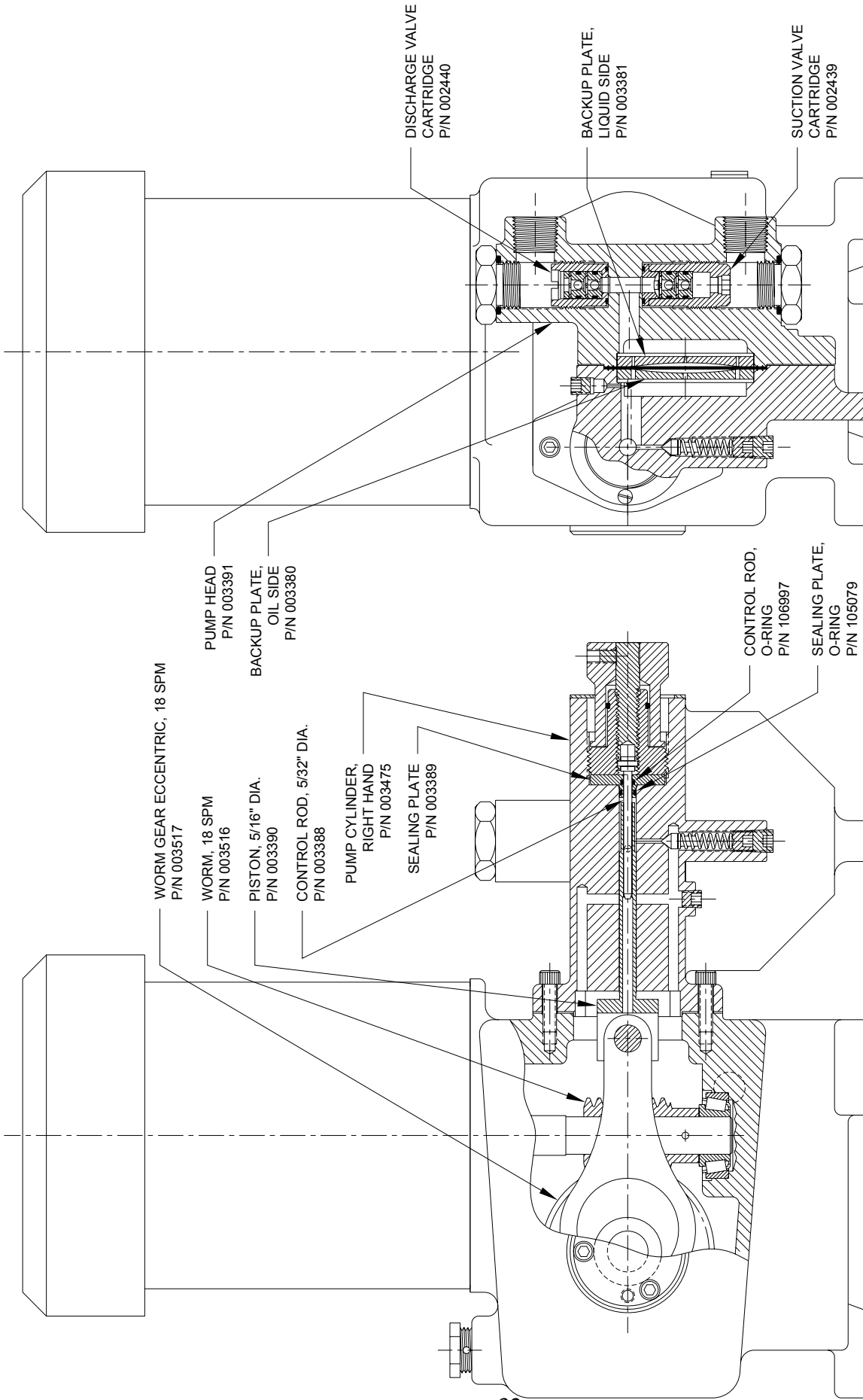

**DRAWING S00091**  
**MODEL 481 LOW VOLUME PUMP**

## THEORY OF OPERATION

The instructions below are for Neptune’s optional Double Diaphragm Kit which is available for the Neptune Series 500, 500-A, and 560 “dia-Pumps”.

Use of a double diaphragm allows diaphragm to be monitored and provides an early warning upon failure of either diaphragm allowing repairs to be made before process fluid mix with the pump hydraulic fluid.

Neptune’s double diaphragm is a kit which may be retrofitted to any pump currently in service or may be installed on a new pump at the factory.

**Figure 1** illustrates a Double Diaphragm Assembly. An intermediate plate is located between the oil and liquid heads with one diaphragm on each side of the intermediate plate. The Intermediate Plate is connected to a rupture alarm or pressure switch via a capillary system. The area between the diaphragms is evacuated. Rupture in either diaphragm produces an increase in volume and, therefore, a pressure increase, which can be sensed by a pressure switch for alarm purposes.

### DISASSEMBLY OF INTERMEDIATE PLATE

- 1.0.0 Shut pump off and disconnect suction and discharge piping. Remove drain plug and drain hydraulic fluid from the gearbox.
- 1.0.1 Remove 8 Screws and remove the liquid head assembly. Some hydraulic oil and process fluid will spill out when the head is removed.
- 1.0.2 The intermediate plate, which is between the pump heads can be removed easily.
- 1.0.3 Remove the rupture alarm (pressure switch) and clean the capillary system.
- 1.0.4 Replace one or both diaphragms if needed.
- 1.0.5 To reassemble reverse above procedure. Be certain that parts align properly.

### VACUUM AIR FROM INTERMEDIATE SPACE

- 1.0.6 Open valve Item No. 5 (**Figure 2**).
- 1.0.7 To remove air, attach the vacuum pump with a hose connection Item No. 6 to the valve Item No. 5 (**Figure 5**). The intermediate space is evacuated to 3 psig for normal operating conditions.

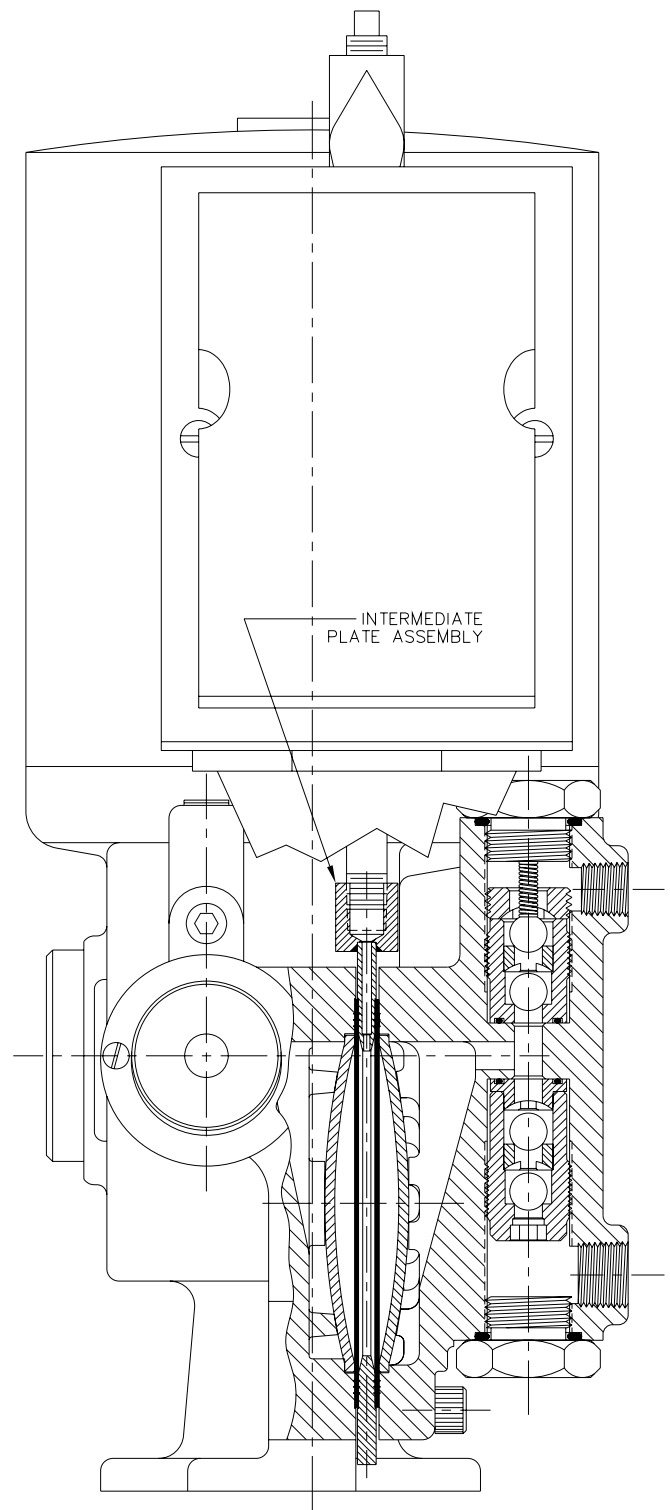

**FIGURE 1**

**ADDENDUM: Special instructions for Series 500, 500-A & 560 “dia-Pumps” with Double Diaphragm**

- 1.0.8 Close valve Item No. 5
- 1.0.9 Remove the vacuum pump. Plug valve Item No. 5 with a 316SS pipe plug Item No. 12
- 1.0.10 Reinstall the Pump
- 1.0.11 Follow procedure in Neptune Standard Operating and Instruction Manual for Initial Pump Startup

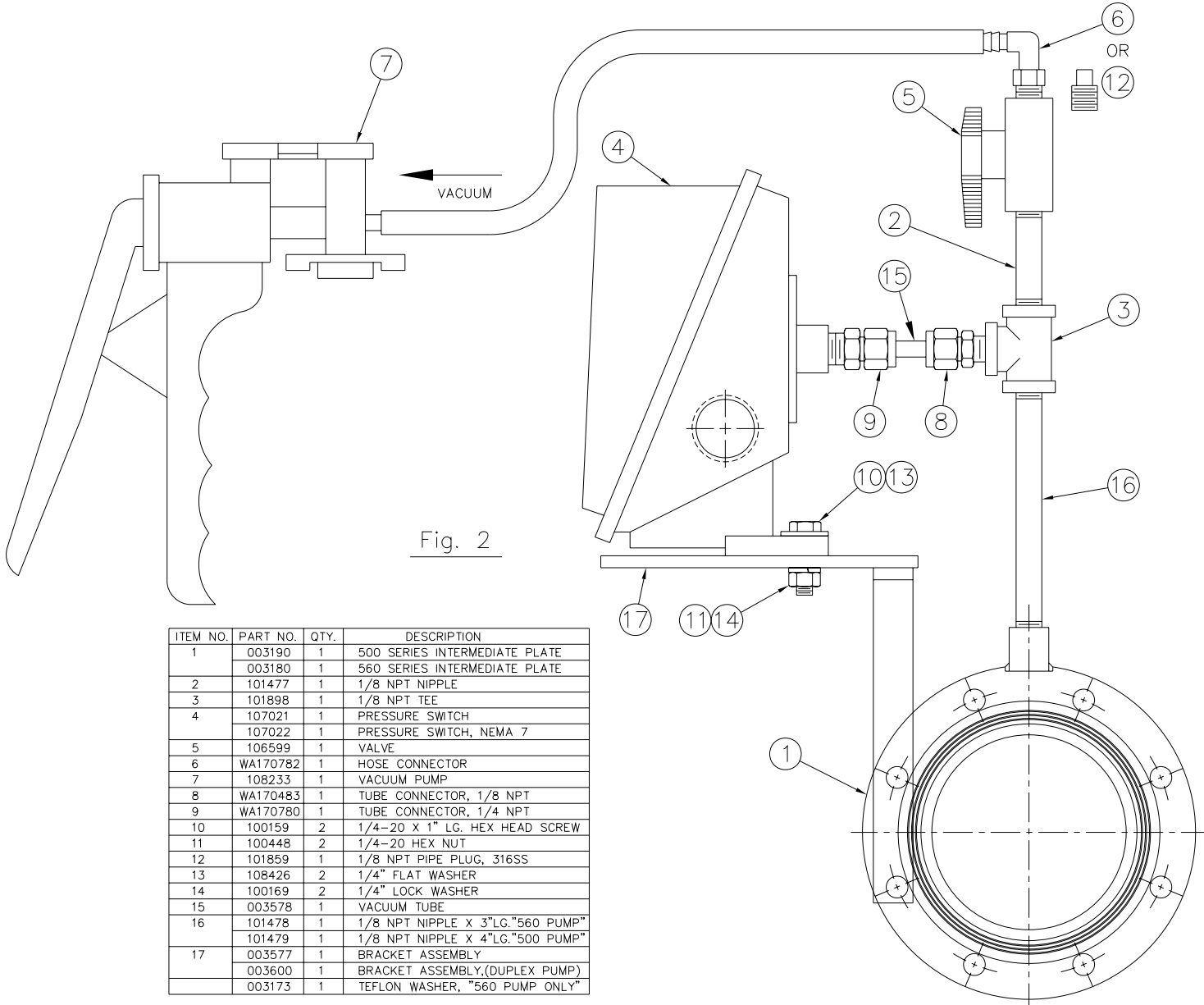

**NOTE:** Neptune furnishes a Mityvac<sup>®</sup> vacuum pump from Mityvac<sup>®</sup> No. 6810 automotive test kit available at many automotive parts stores. (Unit furnished by Neptune is less gage and automotive adapters)

**1. CHEMICAL PRODUCT AND COMPANY IDENTIFICATION**

**Product Name:** EP 68 Gear Oil  
**Product Code:**  
**Generic Name:** Heavy-duty, Multi-grade Gear Oil  
**Chemical Family:** Petroleum Hydrocarbons & Additives  
**Manufacturer:** Scot Lubricants  
 1801 E. Tremont Street  
 P.O. Box 326  
 Allentown, PA 18105

**Emergency Telephone Numbers**  
**Information:** 610-433-2527 8am-5pm - EST M-F  
**CHEMTREC:** 800-424-9300 24 hrs – every day

**2. CAUTION Summary of Hazards**

May cause mild eye irritation and/or mild skin irritation and inflammation. Avoid eye contact and prolonged and/or repeated skin contact.

**HAZARD RATING**

<b>TOXICITY – 1</b>	<b>0=INSIGNIFICANT 1=SLIGHT</b>
<b>FLAMMABILITY – 1</b>	<b>2=MODERATE 3=HIGH</b>
<b>REACTIVITY – 1</b>	<b>4=EXTREME</b>

**3. Fire Fighting Measures**

<b>Flash Point (Method)</b>	<b>Autoignition Temperature (Method)</b>	<b>Flammable Limits in Vol</b>
-----------------------------	--	--------------------------------

**4. FIRST AID MEASURES**

**INHALATION:** Move to fresh air

**EYE CONTACT:** Flush with water for at least 15 minutes. If irritation persists, obtain medical assistance.

**SKIN CONTACT:** Wash with soap and water until no odor remains. If redness or swelling develops, obtain medical assistance. Wash clothing before reuse.

**INGESTION;** Practically non-toxic. Induction of vomiting not required. Obtain emergency medical attention. Small amounts, which accidentally enter mouth, should be rinsed out until taste of it is gone.

**5. FIRE FIGHTING MEASURES**

**FLASHPOINT (METHOD):** 390°F Minimum COC; 201°C Minimum COC

**FLAMMABLE LIMITS:** Not established.

**AUTO-IGNITION TEMP:** 675°F Estimated; 359°C Estimated

**EXTINGUISHING MEDIA:** Water spray, dry chemical, carbon dioxide (CO2), foam.

**FIRE FIGHTING INSTRUCTIONS:** Avoid breathing smoke and vapor.

**FIRE FIGHTING EQUIPMENT:** Wear self-contained breathing apparatus and protective clothing. Use water spray to keep fire-exposed containers cool.

**HAZARDOUS COMBUSTION PRODUCTS:** Normal combustion forms carbon dioxide and water vapor; incomplete combustion can produce carbon monoxide.

**Revision: 05/05/2007**

NA= Not Applicable

ND=No Data

NE=Not Established

---

## 6. ACCIDENTAL RELEASE MEASURES

---

**SPILLS OR LEAKS:** Contain spills, advise EPA, state agency, if required. Absorb on inert material, shovel, sweep, or vacuum spill.

---

## 7. HANDLING AND STORAGE

---

**NFPA Class IIIB Storage.** Wash thoroughly after handling.

---

## 8. EXPOSURE CONTROLS/PERSONAL PROTECTION

---

**VENTILATION:** Ventilate as needed to comply with exposure limit. General Dilution ventilation acceptable.

**PERSONAL PROTECTIVE EQUIPMENT –**

**EYE:** Splash proof chemical goggles recommended to protect against splash of product.

**GLOVES:** Protective gloves recommended when prolonged skin contact cannot be avoided. The following glove materials are acceptable: polyvinyl chloride (PVC); neoprene; nitrile; polyvinyl alcohol; viton.

**RESPIRATOR:** Concentration in air determines protection needed. Use only NIOSH certified respiratory protection. Respiratory protection usually not needed unless product is heated or misted. Half-mask air purifying respirator with dust/mist filters or HEPA filter cartridges is acceptable to 10 times the exposure limit. Full-face air purifying respirator with dust/mist filters of HEPA filter cartridges is acceptable to 50 times the exposure limit. Protection by air purifying respirators is limited. Use a positive pressure demand full-face supplied air respirator or SCBA for exposures above 50X the exposure limit. If exposure is above IDLH (immediately dangerous to life and health) or there is the possibility of an uncontrolled release or exposure levels are unknown, then use a positive pressure demand full-face supplied air respirator with escape bottle or SCBA.

**OTHER:** If contact is unavoidable, wear chemical resistant clothing. The following materials are acceptable as protective clothing materials: polyvinyl alcohol (PVA); polyvinyl chloride (PVC); neoprene; nitrile; viton; polyurethane. Launder soiled clothes.

---

## 9. PHYSICAL AND CHEMICAL PROPERTIES

---

**APPEARANCE/ODOR:** AMBER FLUID/SLIGHT ODOR

**VAPOR PRESSURE** <0.0001 (MM HG @ 20°C)

**MOLECULAR WEIGHT:** N/A (G/MOLE)

**SOLUBILITY IN WATER:** NIL (% BY VOLUME)

**EVAPORATION RATE:** 1000X SLOWER (ETHYL ETHER=1)

**SPECIFIC GRAVITY:** 0.86 (WATER=1)

**VISCOSITY:** 55 SUS @ 210°F

68 CST @ 40°C

**.BOILING POINT:** HIGH

**MELTING POINT:** N/A

**PACKING DENSITY:** N/A

**OCTANOL/WATER COEFF:** N.D.

**ODOR THRESHOLD:** N.D.

**VAPOR DENSITY:** 10+ (AIR=1)

---

## 10. STABILITY AND REACTIVITY

---

**STABILITY:** Stable

**CONDITIONS TO AVOID:** None known.

**MATERIALS TO AVOID:** Strong oxidizing agents.

**HAZARDOUS POLYMERIZATION:** Will not occur.

**HAZARDOUS DECOMPOSITION:** Combustion will produce carbon monoxide and asphyxiants.

---

## 11. TOXICOLOGICAL INFORMATION

---

**FOR THE PRODUCT –**

**INHALATION:** Low acute toxicity. **SKIN:** Practically non-toxic if absorbed. Mild irritation with prolonged or repeated contact. **EYE:** Mildly irritating on contact. **ORAL:** Practically non-toxic. Acute toxicity: estimated oral LD50 in rats is: >15 g/kg. Estimated draize skin irritation score is: 2.10 out of 8.0

---

**Revision:** 05/05/2007

NA= Not Applicable

ND=No Data

NE=Not .Established

**11. TOXICOLOGICAL INFORMATION – cont’d**

**SEVERELY SOLVENT REFINED HEAVY PARAFFINIC PETROLEUM OIL:** INHALATION: Low acute toxicity. SKIN: Practically non-toxic if absorbed; may cause moderate irritation with prolonged and repeated contact. EYE: Minimally irritating on contact. INGESTION: Practically non-toxic if swallowed.

**CALCIUM SULFONATE:** INHALATION/INGESTION: No data available. SKIN: Moderate irritant.

Cause allergic skin reaction in animals. EYE: Moderate to severe irritation.

**BUTYLATED PHENOL:** No data available for all routes of exposure.

**ZINC DIALKYL DITHIOPHOSPHATE:** INHALATION: Toxic hydrogen sulfide is generated when heated above 155 deg. F. This can cause respiratory collapse, coma, or death. SKIN: Prolonged or repeated contact may cause moderate irritation, redness, drying, cracking, and dermatitis. EYE: Irritant. ORAL: Harmful if swallowed.

**ACRYLIC COPOLYMER:** No data available for all routes of exposure.

**2-ETHYLHEXANOL:** INHALATION: Overexposure may cause nose/throat irritation, nasal discomfort and discharge, chest pain, cough, headache, nausea, vomiting. SKIN: Irritant. Prolonged/repeated contact may cause redness and swelling. Prolonged widespread absorption caused CNS (Brain) depression, stupor, and unconsciousness in animals. EYE: Severe irritant. May cause corneal injury. ORAL: Moderately toxic. May cause abdominal discomfort, nausea, vomiting, diarrhea, unconsciousness, and other CNS (Brain) effects. Liver and kidney injury (repeated ingestion). PREGNANT RATS: Skin contact up to 3 ml/kg. Maternal toxicity, but no birth defects; oral dose 2 ml/kg. Embryo/fetal toxicity and possibly increased birth defects.

**TOLUENE:** INHALATION: Vapor harmful. Overexposure to high concentration will cause eye, nose, and throat irritation. CNS (Brain) effects, dizziness, breathing difficulties, coma, and death. Reports of heart beat irregularities from massive exposure. Prolonged overexposure can cause brain, liver, kidney effects and/or damage. ORAL: Harmful or fatal if swallowed. PULMONARY ASPIRATION HAZARD: Can enter lungs and cause damage.

PREGNANT: May cause mental and/or growth retardation in children of female solvent abusers. Prolonged breathing in rats was toxic to fetuses and mothers – 15000 ppm. No birth defects-5000 ppm. No effects 750 ppm.

**12. ECOLOGICAL INFORMATION**

**ECOTOXICITY:** No data available.

**13. DISPOSAL INFORMATION**

Follow federal, state, and local regulations. Not RCRA hazardous waste if uncontaminated. If “used”, RCRA criteria (ignitability, reactivity, corrosivity, toxicity characteristics) must be determined. Do not flush to drain/storm sewer. Contract to authorized disposal service.

**14. TRANSPORTATION INFORMATION**

**DOT**

PROPER SHIPPING NAME	Petroleum Lubricating Oil
HAZARD CLASS	Not regulated
ID NUMBER	Not regulated
LABEL REQUIRED	Not regulated
IMDG PROPER SHIPPING NAME	N.D.
IATA PROPER SHIPPING NAME	N.D.

**15. REGULATORY INFORMATION**

TSCA: This material complies with the TOXIC SUBSTANCES CONTROL ACT (15 USC 2601-2629) and is listed in the TSCA Inventory.

SARA 302 THRESHOLD PLANNING QUANTITY		N/A	
SARA 304 REPORTABLE QUANTITY		N/A	
SARA 311/312 REPORTING	Health	Immediate (acute)	No
	Health	Delayed (Chronic)	No
	Physical	Fire	No
	Physical	Sudden Release of Pressure	No
	Physical	Reactive	No

When a product and/or component is listed below, the regulatory list on which it appears is indicated.

ZINC DIALKYL DITHIOPHOSPHATE – NJ 01  
 TOLUENE – CA FL MA MN NJ PA 01 07  
 2-ETHYLHEXANOL – MA PA

- |                     |                           |                       |
|---------------------|---------------------------|-----------------------|
| 01=SARA 313         | 02=SARA 302/304           | 03=IARC CARCINOGEN    |
| 04=OSHA CARCINOGEN  | 05=ACGIH CARCINOGEN       | 06=NTP CARCINOGEN     |
| 07=CERCLA 302.4     | 08=WHMIS CONTROLLED PROD. |                       |
| 10=OTHER CARCINOGEN |                           |                       |
| PA=PA RTK           | NJ=NEW JERSEY RTK         | CA=CALIFORNIA PROP 65 |
| MA=MASS. RTK        | MI=MICHIGAN 406           | MN=MINNESOTA RTK      |
| FL=FLORIDA          | RI=RHODE ISLAND           | IL=ILLINOIS           |
| NY=NEW YORK         | WV=WEST VIRGINIA          | CT=CONNECTICUT        |
| LA=LOUISIANA        | ME=MAINE                  | OH=OHIO               |

**16. OTHER INFORMATION**

**SCOT LUBRICANTS OF PA, INC.**  
**1801 E. TREMONT STREET**  
**P.O. BOX 326**  
**ALLENTOWN, PA 18105**  
**610-433-2527**

The information on this form is furnished solely for the purpose of compliance with the OSHA Act, and shall not be used for any other purpose. The information herein is given in good faith and is based on data considered accurate. However, no warranty, expressed or implied, is made regarding the accuracy of these data or the result to be obtained from the use thereof.

---

**Revision: 05/05/2007**                      NA=Not Applicable                      ND=No Data                      NE=Not Established

**3. CHEMICAL PRODUCT AND COMPANY IDENTIFICATION**

**Product Name:** EP 90 Gear Oil  
**Product Code:**  
**Generic Name:** Heavy-duty, Multi-grade Gear Oil  
**Chemical Family:** Petroleum Hydrocarbons & Additives  
**Manufacturer:** Scot Lubricants  
 1801 E. Tremont Street  
 P.O. Box 326  
 Allentown, PA 18105

**Emergency Telephone Numbers**  
**Information:** 610-433-2527 8am-5pm - EST M-F  
**CHEMTREC:** 800-424-9300 24 hrs - every day

**4. CAUTION Summary of Hazards**

May cause mild eye irritation and/or mild skin irritation and inflammation. Avoid eye contact and prolonged and/or repeated skin contact.

**HAZARD RATING**

<b>TOXICITY - 1</b>	<b>0=INSIGNIFICANT 1=SLIGHT</b>
<b>FLAMMABILITY - 1</b>	<b>2=MODERATE 3=HIGH</b>
<b>REACTIVITY - 1</b>	<b>4=EXTREME</b>

**3. Fire Fighting Measures**

<b>Flash Point (Method)</b>	<b>Autoignition Temperature (Method)</b>	<b>Flammable Limits in Vol</b>
-----------------------------	--	--------------------------------

**4. FIRST AID MEASURES**

**INHALATION:** Move to fresh air  
**EYE CONTACT:** Flush with water for at least 15 minutes. If irritation persists, obtain medical assistance.  
**SKIN CONTACT:** Wash with soap and water until no odor remains. If redness or swelling develops, obtain medical assistance. Wash clothing before reuse.  
**INGESTION;** Practically non-toxic. Induction of vomiting not required. Obtain emergency medical attention. Small amounts, which accidentally enter mouth, should be rinsed out until taste of it is gone.

**5. FIRE FIGHTING MEASURES**

**FLASHPOINT (METHOD):** 390°F Minimum COC; 201°C Minimum COC  
**FLAMMABLE LIMITS:** Not established.  
**AUTO-IGNITION TEMP:** 675°F Estimated; 359°C Estimated  
**EXTINGUISHING MEDIA:** Water spray, dry chemical, carbon dioxide (CO2), foam.  
**FIRE FIGHTING INSTRUCTIONS:** Avoid breathing smoke and vapor.  
**FIRE FIGHTING EQUIPMENT:** Wear self-contained breathing apparatus and protective clothing. Use water spray to keep fire-exposed containers cool.  
**HAZARDOUS COMBUSTION PRODUCTS:** Normal combustion forms carbon dioxide and water vapor; incomplete combustion can produce carbon monoxide.

**Revision: 05/05/2007**                      NA= Not Applicable                      ND=No Data                      NE=Not Established



**11. TOXICOLOGICAL INFORMATION – cont’d**

**SEVERELY SOLVENT REFINED HEAVY PARAFFINIC PETROLEUM OIL:** INHALATION: Low acute toxicity. SKIN: Practically non-toxic if absorbed; may cause moderate irritation with prolonged and repeated contact. EYE: Minimally irritating on contact. INGESTION: Practically non-toxic if swallowed.

**CALCIUM SULFONATE:** INHALATION/INGESTION: No data available. SKIN: Moderate irritant. Cause allergic skin reaction in animals. EYE: Moderate to severe irritation.

**BUTYLATED PHENOL:** No data available for all routes of exposure.

**ZINC DIALKYL DITHIOPHOSPHATE:** INHALATION: Toxic hydrogen sulfide is generated when heated above 155 deg. F. This can cause respiratory collapse, coma, or death. SKIN: Prolonged or repeated contact may cause moderate irritation, redness, drying, cracking, and dermatitis. EYE: Irritant. ORAL: Harmful if swallowed.

**ACRYLIC COPOLYMER:** No data available for all routes of exposure.

**2-ETHYLHEXANOL:** INHALATION: Overexposure may cause nose/throat irritation, nasal discomfort and discharge, chest pain, cough, headache, nausea, vomiting. SKIN: Irritant. Prolonged/repeated contact may cause redness and swelling. Prolonged widespread absorption caused CNS (Brain) depression, stupor, and unconsciousness in animals. EYE: Severe irritant. May cause corneal injury. ORAL: Moderately toxic. May cause abdominal discomfort, nausea, vomiting, diarrhea, unconsciousness, and other CNS (Brain) effects. Liver and kidney injury (repeated ingestion). PREGNANT RATS: Skin contact up to 3 ml/kg. Maternal toxicity, but no birth defects; oral dose 2 ml/kg. Embryo/fetal toxicity and possibly increased birth defects.

**TOLUENE:** INHALATION: Vapor harmful. Overexposure to high concentration will cause eye, nose, and throat irritation. CNS (Brain) effects, dizziness, breathing difficulties, coma, and death. Reports of heart beat irregularities from massive exposure. Prolonged overexposure can cause brain, liver, kidney effects and/or damage. ORAL: Harmful or fatal if swallowed. PULMONARY ASPIRATION HAZARD: Can enter lungs and cause damage. PREGNANT: May cause mental and/or growth retardation in children of female solvent abusers. Prolonged breathing in rats was toxic to fetuses and mothers – 15000 ppm. No birth defects-5000 ppm. No effects 750 ppm.

**12. ECOLOGICAL INFORMATION**

**ECOTOXICITY:** No data available.

**13. DISPOSAL INFORMATION**

Follow federal, state, and local regulations. Not RCRA hazardous waste if uncontaminated. If “used”, RCRA criteria (ignitability, reactivity, corrosivity, toxicity characteristics) must be determined. Do not flush to drain/storm sewer. Contract to authorized disposal service.

**14. TRANSPORTATION INFORMATION**

<b>DOT</b>	
PROPER SHIPPING NAME	Petroleum Lubricating Oil
HAZARD CLASS	Not regulated
ID NUMBER	Not regulated
LABEL REQUIRED	Not regulated
IMDG PROPER SHIPPING NAME	N.D.
IATA PROPER SHIPPING NAME	N.D.

**15. REGULATORY INFORMATION**

TSCA: This material complies with the TOXIC SUBSTANCES CONTROL ACT (15 USC 2601-2629) and is listed in the TSCA Inventory.

SARA 302 THRESHOLD PLANNING QUANTITY		N/A	
SARA 304 REPORTABLE QUANTITY		N/A	
SARA 311/312 REPORTING	Health	Immediate (acute)	No
	Health	Delayed (Chronic)	No
	Physical	Fire	No
	Physical	Sudden Release of Pressure	No
	Physical	Reactive	No

When a product and/or component is listed below, the regulatory list on which it appears is indicated.

ZINC DIALKYL DITHIOPHOSPHATE – NJ 01  
 TOLUENE – CA FL MA MN NJ PA 01 07  
 2-ETHYLHEXANOL – MA PA

- |                     |                           |                       |
|---------------------|---------------------------|-----------------------|
| 01=SARA 313         | 02-SARA 302/304           | 03=IARC CARCINOGEN    |
| 04-OSHA CARCINOGEN  | 05=ACGIH CARCINOGEN       | 06=NTP CARCINOGEN     |
| 07=CERCLA 302.4     | 08=WHMIS CONTROLLED PROD. |                       |
| 10-OTHER CARCINOGEN |                           |                       |
| PA=PA RTK           | NJ=NEW JERSEY RTK         | CA=CALIFORNIA PROP 65 |
| MA=MASS. RTK        | MI=MICHIGAN 406           | MN=MINNESOTA RTK      |
| FL=FLORIDA          | RI=RHODE ISLAND           | IL=ILLINOIS           |
| NY=NEW YORK         | WV=WEST VIRGINIA          | CT=CONNECTICUT        |
| LA=LOUISIANA        | ME=MAINE                  | OH=OHIO               |

**16. OTHER INFORMATION**

**SCOT LUBRICANTS OF PA, INC.**  
**1801 E. TREMONT STREET**  
**P.O. BOX 326**  
**ALLENTOWN, PA 18105**  
**610-433-2527**

The information on this form is furnished solely for the purpose of compliance with the OSHA Act, and shall not be used for any other purpose. The information herein is given in good faith and is based on data considered accurate. However, no warranty, expressed or implied, is made regarding the accuracy of these data or the result to be obtained from the use thereof.

Revision: 05/05/2007

NA=Not Applicable

ND=No Data

NE=Not Established



**BLANK  
PAGE**

# High Viscosity “V-Pumps”

## Purpose

Neptune high viscosity, flat diaphragm “V-Pumps” are designed to accurately meter viscous fluids up to 5000 cP such as polymers and other thick liquids.

## Features/Benefits

- Handles moderate viscosity fluids.
- Standard flat diaphragm.
- Large internal porting with a large, single ball, suction check valve.
- Capacities to 30 gph (113 lph) at 100 psi (8 kg/cm<sup>2</sup>).
- Available in all 316SS with SS trim.
- Electric or pneumatic stroke control options and variable speed drives.
- Variable Oil By-pass™ stroke adjustment mechanism provides better valve performance than variable linkage designs.
- Teflon® diaphragm withstands most chemicals.

Variable Oil By-pass™ stroke adjustment allows an adjustable time delay between the end of the suction stroke and the beginning of the discharge stroke. This delay permits the ball to seat fully before pumping resumes, even in the heaviest liquids, so that pumping accuracy remains high. (See Bulletin DP-1100 for details on “How It Works”.)

**Neptune**  
A DOVER COMPANY

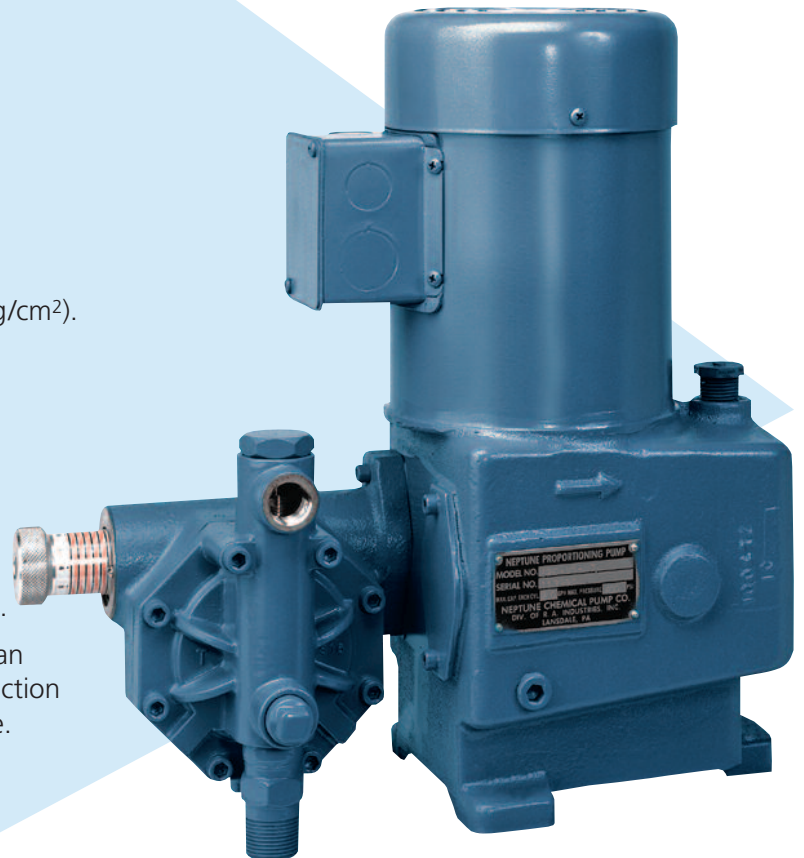

**MODEL  
520-V5-N3**

## Materials of Construction

CODE	HEAD	VALVES	DIAPHRAGM	O-RINGS
N3	316SS	316SS	Teflon®	Viton

For more information on Neptune Series 500 Pumps and Control Options request Bulletins DP-1100 and DP-500E.

For Higher Viscosity and Higher Volume Applications request Bulletin DP-7000.

## **CROSS SECTIONAL VIEW**

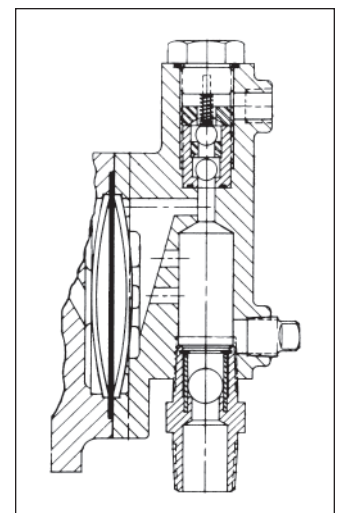

# Neptune Series V Flat Diaphragm Pumps

## SELECTION CHART

### SIMPLEX MODELS (DUPLEX AVAILABLE)

Standard Motor: 1/3 HP-single phase-115VAC-60 cycles-TEFC



**MODEL 532-VS-N3**

- Gearbox, drive train and motor options are identical to Series 500 "dia-PUMP."

MODEL NUMBER	MATERIALS OF CONSTRUCTION	CAPACITY GPH (LPH) @ 100 PSI	MAXIMUM PRESSURE PSI (KG/CM <sup>2</sup> )	PISTON DIAMETER	STROKES PER MINUTE	SHIPPING WEIGHT LBS.
515-VS-N3	316SS	3.0 (11.3)	900 (63)	0.500	117	70
520-VS-N3	316SS	2.0 (7.5)	400 (28)	0.687	37	70
522-VS-N3	316SS	4.0 (15.1)	500 (35)	0.687	72	70
525-VS-N3	316SS	7.0 (26.5)	700 (49)	0.687	117	70
530-VS-N3	316SS	5.5 (20.8)	300 (21)	1.062	37	70
532-VS-N3	316SS	11.0 (41.6)	300 (21)	1.062	72	70
535-VS-N3	316SS	18.0 (68.0)	300 (21)	1.062	117	70
537-VS-N3	316SS	22.0 (83.0)	300 (21)	1.062	144	70
547-VS-N3	316SS	30.0 (113.0)	200 (14)*	1.187	144	70

\*300 PSI (21 KG/CM<sup>2</sup>) at 1/2 HP

## DIMENSIONS

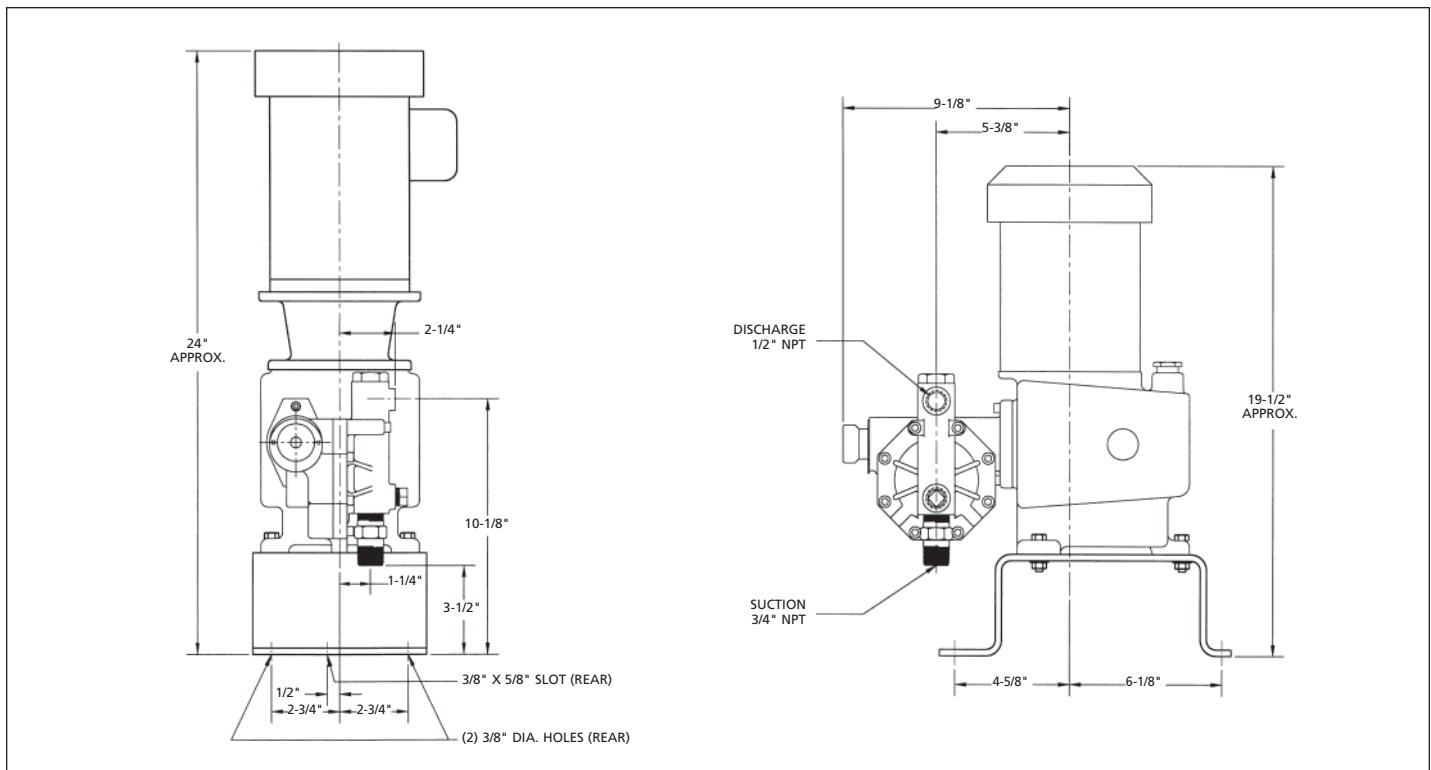

SOLD BY:

P.O. Box 247 • Lansdale, PA 19446-0247  
 Tel: 215-699-8700 • Fax: 215-699-0370  
 Toll-Free Tel: 1-888-3NEPTUNE (1-888-363-7886)  
 Toll-Free Fax: 1-800-255-4017  
 Web Site: <http://www.neptune1.com>  
 E-mail: [pump@neptune1.com](mailto:pump@neptune1.com)



# Section

# 5

# MOTOR DATA

NEPTUNE P/N : 100745  
 MANUFACTURER : LEESON  
 MODEL NUMBER : 111930  
 HORSEPOWER : 1/HHP  
 TYPE : S.C.I.  
 FRAME SIZE : D56C  
 PHASE : 3 PH  
 FREQUENCY : 50/60 HZ  
 VOLTAGE : 208-230/460  
 ENCLOSURE :  $\Delta/\square/\circ$   
 INSULATION : B4  
 R P M : 1425/1725  
 FULL LOAD AMPS : 1.7-1.8/0.9  
 LOCKED ROTOR AMPS : 11.10  
 FULL LOAD EFFICIENCY : 78.5  
 FULL LOAD POWER FACTOR : 67  
 SERVICE FACTOR : 1.0  
 WEIGHT : 34 LBS

AUTO PROTECTION  
 CLASS I GROUP C & D; CLASS II GROUPS F & G  
 TEMP CODE T3C

