

# WINKLER+ DÜNNEBIER

# WD

## 241 G/GS



## Rotary Envelope Making Machine





# Rotary Envelope Making Machine Type 241 G/GS

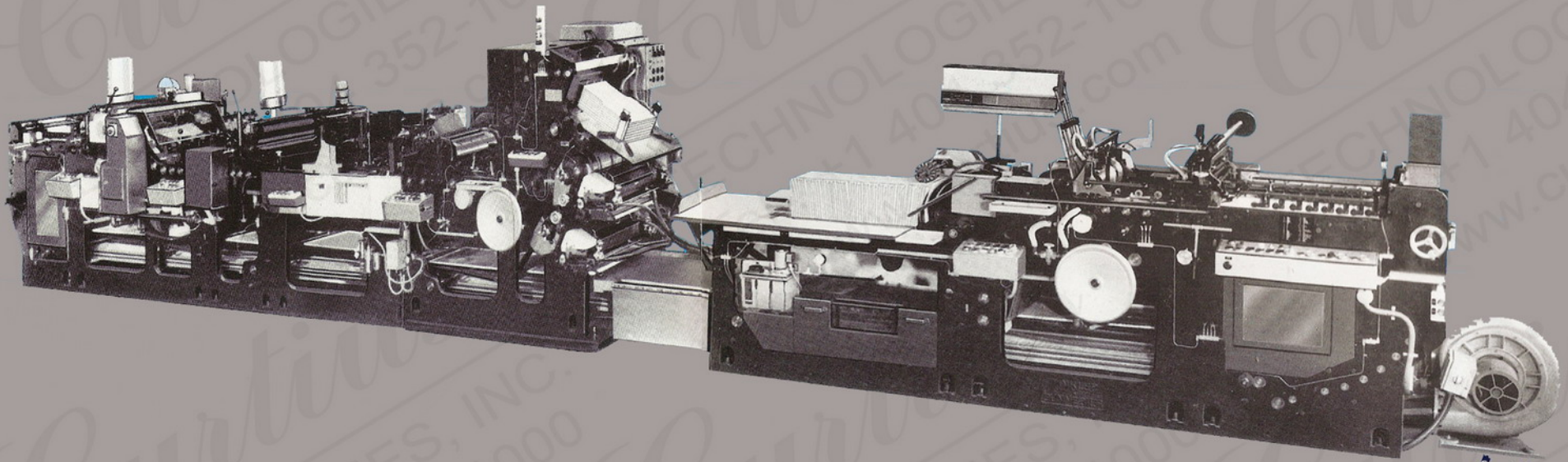
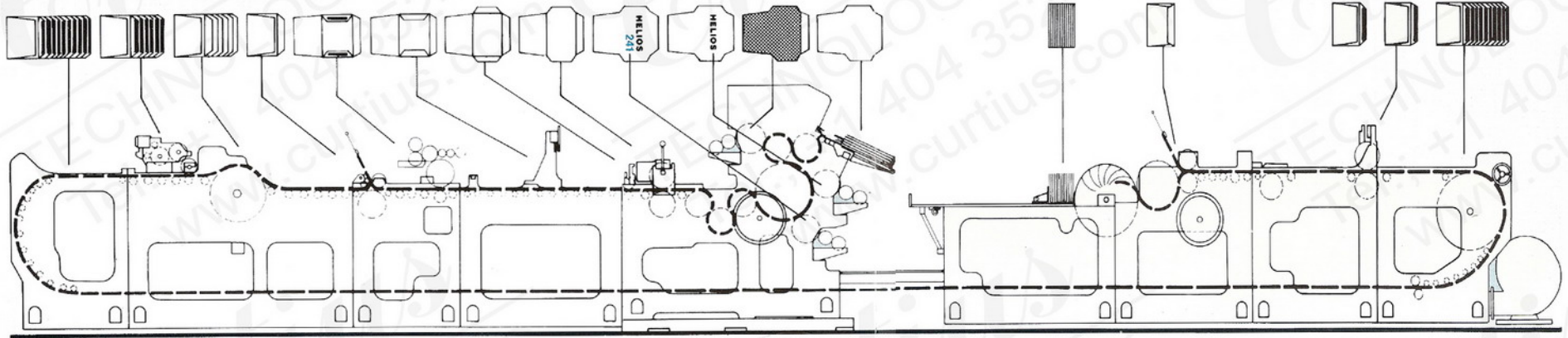

HELOS 241 G





# Rotary Envelope Making Machine Type 241 G/GS

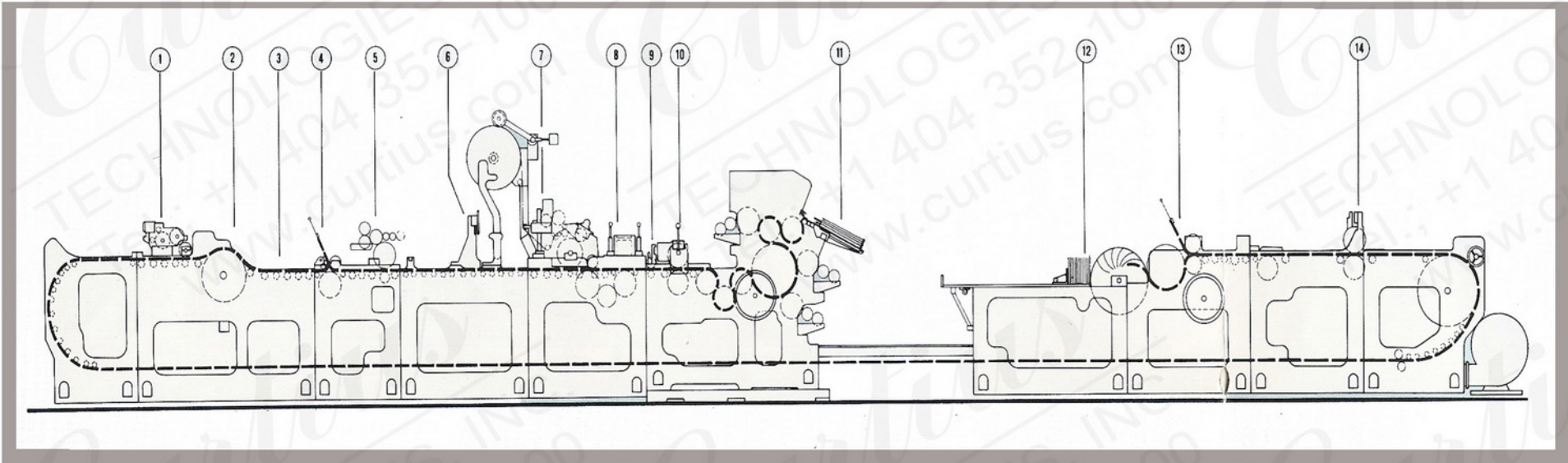

## HELOS 241 GS

1. seal flap gumming section
2. staggering section
3. side flap folding section  
(outer side flaps)
4. bottom flap gumming section
5. side flap gumming section
6. side flap folding section
7. window material section
8. window cutting section
9. longitudinal scoring section
10. transversal scoring section
11. feed
12. delivery
13. seal flap folding section
14. aligner section





# Rotary Envelope Making Machine Type 241 G/GS

Verstellbarkeit

size ranges

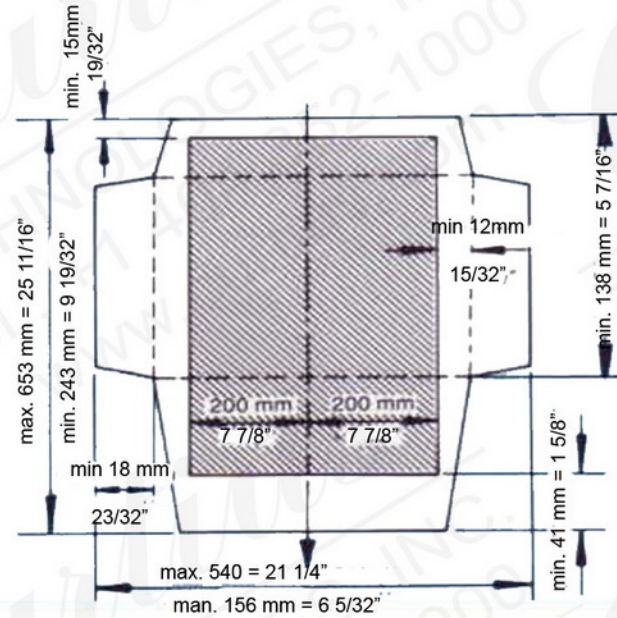
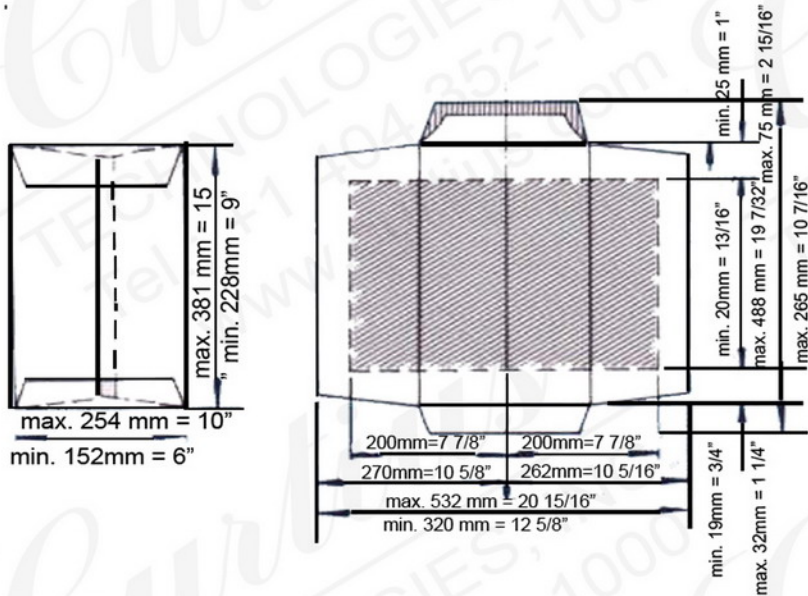
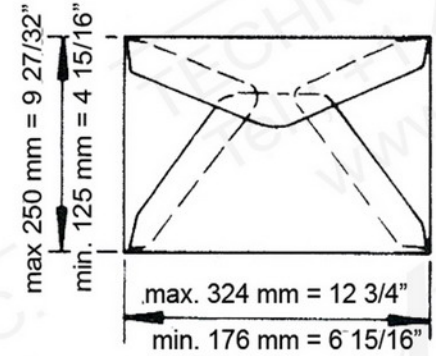
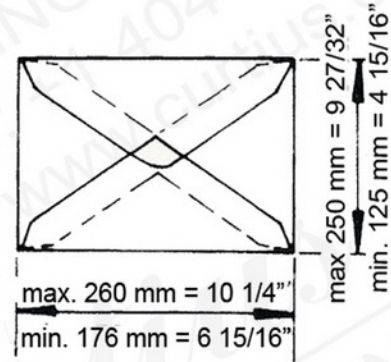
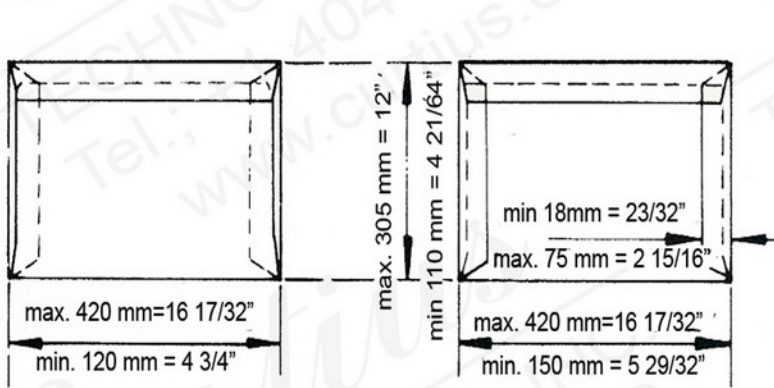

1  
2

585 mm = 23<sup>1</sup>/<sub>32</sub>"  
570 mm = 22<sup>7</sup>/<sub>16</sub>"

450 mm = 17<sup>23</sup>/<sub>32</sub>"

70 – 165 g/m<sup>2</sup>

500

400

max. 653 mm = 25<sup>11</sup>/<sub>16</sub>"  
min. 243 mm = 9<sup>19</sup>/<sub>32</sub>"

max. 540 mm = 21<sup>1</sup>/<sub>4</sub>"  
min. 156 mm = 6<sup>5</sup>/<sub>32</sub>"

max. 500 mm = 20"

max. 280 mm = 11<sup>1</sup>/<sub>32</sub>"  
min. 55 mm = 2<sup>5</sup>/<sub>32</sub>"

max. 420 mm = 16<sup>1</sup>/<sub>2</sub>"  
min. 30 mm = 1<sup>3</sup>/<sub>16</sub>"

max. 488 mm = 19<sup>7</sup>/<sub>32</sub>"  
min. 265 mm = 10<sup>7</sup>/<sub>16</sub>"

max. 532 mm = 20<sup>15</sup>/<sub>16</sub>"  
min. 320 mm = 12<sup>5</sup>/<sub>8</sub>"

70 kVA  
85 kVA

12 kW

13.315 × 2.320 × 1.845 mm

14.410 × 2.320 × 2.650 mm

16.500 kg

### Technical Data:

flexographic printing units  
for inside printing  
for outside printing

printing length  
inside printing  
outside printing

printing width

paper weights

max. output  
envelopes/minute  
dextrine and pressure-sensitive  
seal flap gumming  
self-seal  
flap gumming

total length of the blank

total width of the blank

diameter  
of the window material reel

window material length

window material width

machine with supplementary parts for  
pockets with centre seam gumming

total length of blank

total width of blank

power required ca.  
motors  
241 G  
241 GS

electrical heating

dimensions of the machine ca.  
241 G  
241 GS

net weight 241 GS ca.

