

COPRINOX

HEAT EXCHANGER

Code n° **BEM 010 1379**

Location ref: 18

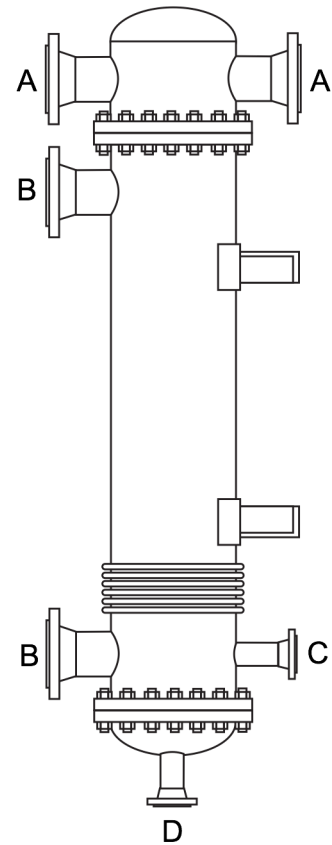
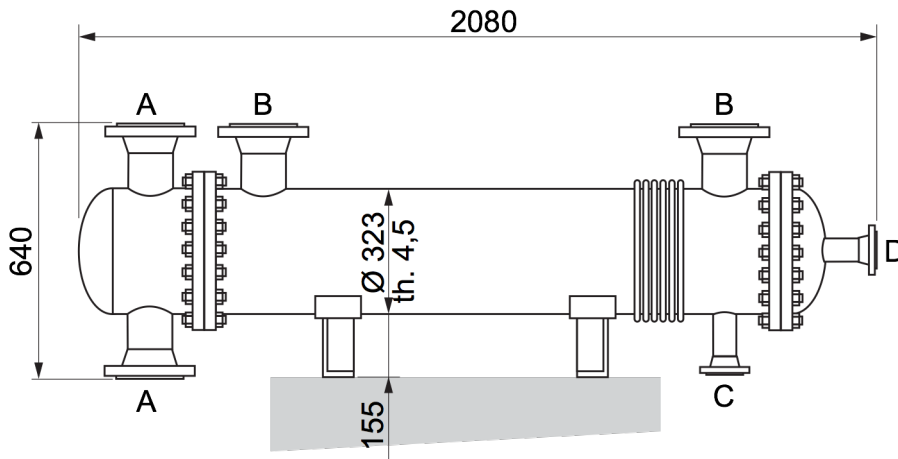

HEATING SURFACE m² <u>10,5</u>		TUBE SIDE		SHELL SIDE																			
Design Pressure KG/cm2 Design Temperature °C Capacity liters		-1 / +5 -10 / +200 75		-1 / +5 -10 / +200 64																			
ANCC or ISPESEL certification: PED Shell side traverse baffles n° <u>5</u> Tube side passes n° <u>2</u>		NOZZLE DIMENSIONS																					
TUBE O.D. <u>19,05</u> TUBE THICKNESS <u>1,65</u> TUBE N° <u>118</u> TUBE EXPAND <input checked="" type="checkbox"/> TUBE WELDED <input checked="" type="checkbox"/> EXPANSION JOINT <input checked="" type="checkbox"/>		<table border="1"> <thead> <tr> <th>Pos</th> <th>Service</th> <th>Size inch.</th> </tr> </thead> <tbody> <tr> <td>A</td> <td>Tube side inlet / outlet</td> <td>DN100</td> </tr> <tr> <td>B</td> <td>Shell side inlet / outlet</td> <td>DN100</td> </tr> <tr> <td>C</td> <td>Shell side condensate outlet</td> <td>DN50</td> </tr> <tr> <td>D</td> <td>Tube side condensate outlet</td> <td>DN50</td> </tr> <tr> <td>E</td> <td></td> <td></td> </tr> </tbody> </table>		Pos	Service	Size inch.	A	Tube side inlet / outlet	DN100	B	Shell side inlet / outlet	DN100	C	Shell side condensate outlet	DN50	D	Tube side condensate outlet	DN50	E			VERTICAL <input checked="" type="checkbox"/> ORIZZONTAL <input checked="" type="checkbox"/> FLOATING HEAD <input type="checkbox"/> U - TUBE BUNDLE <input type="checkbox"/> KETTLE <input type="checkbox"/>	
Pos	Service	Size inch.																					
A	Tube side inlet / outlet	DN100																					
B	Shell side inlet / outlet	DN100																					
C	Shell side condensate outlet	DN50																					
D	Tube side condensate outlet	DN50																					
E																							
MATERIALS SHEEL <u>AISI 316L</u> TUBES <u>AISI 316L</u> TUBESHEET <u>AISI 316L</u> HEAD BONNET OR CHANNEL <u>AISI 316L</u>		<input type="checkbox"/> USED <input type="checkbox"/> USED RECONDITIONED <input checked="" type="checkbox"/> UNUSED																					
WEIGHT (approx) Kg <u>345</u>		NOTE Model BEM10EXP																					
MANUFACTURER: <u>COPRINOX</u>																							