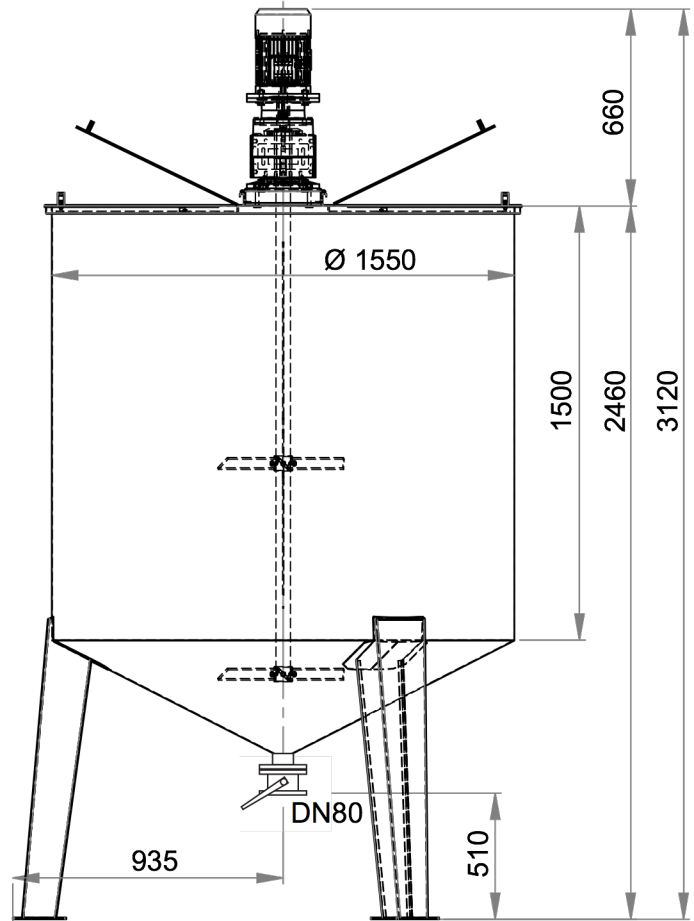
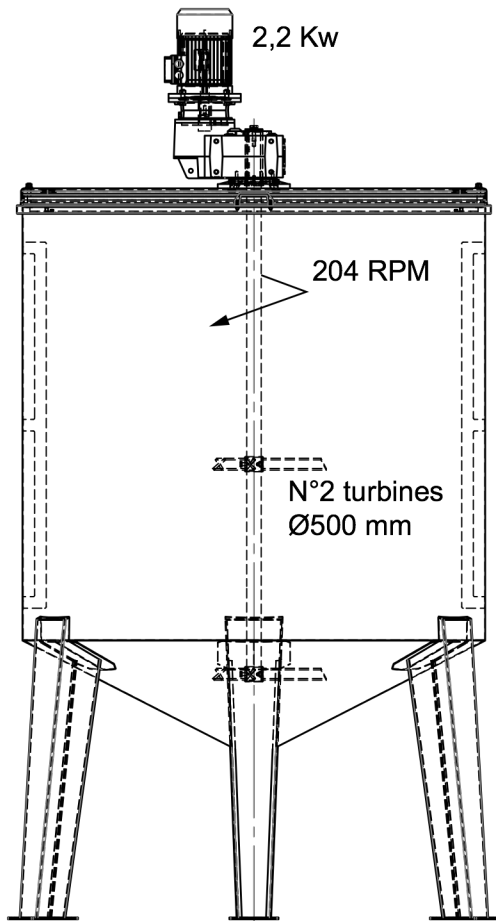

COPRINOX

AGITATED VESSEL

Code n° RA 033 1362

Location ref: 18 T1

CAPACITY LITERS 3.300

SHELL SIDE

JACKET/COIL SIDE

Design Pressure KG/cm2
Design Temperature °C
Material

ATM

AISI 304

ANCC or ISPESL certification: NOT
Availability in stock n° 01 units

NOZZLE DIMENSIONS

Pos	Service	Size inch.
A		
B		
C		
D		
E		

MANUFACTURER: COPRINOX USED
 USED RECONDITIONED
 UNUSED**NOTE** Working capacity: 3000 lt
Model: MIX3000WEIGHT (approx) Kg 375