

# **MAT**

# **MIDI DRILL**

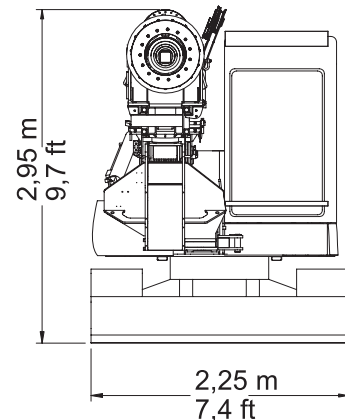

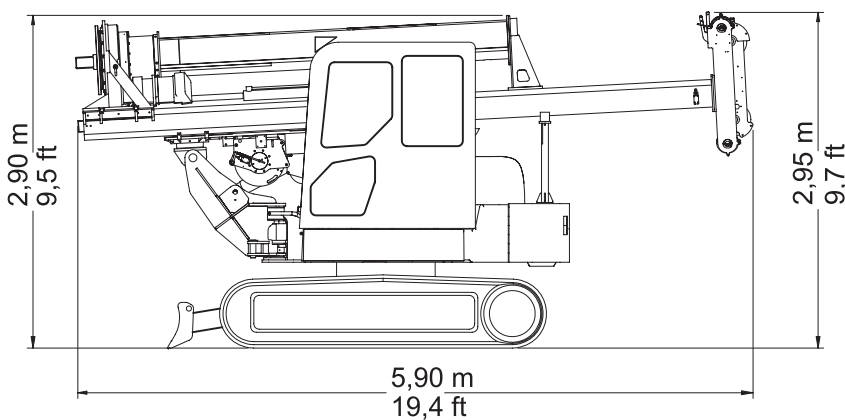
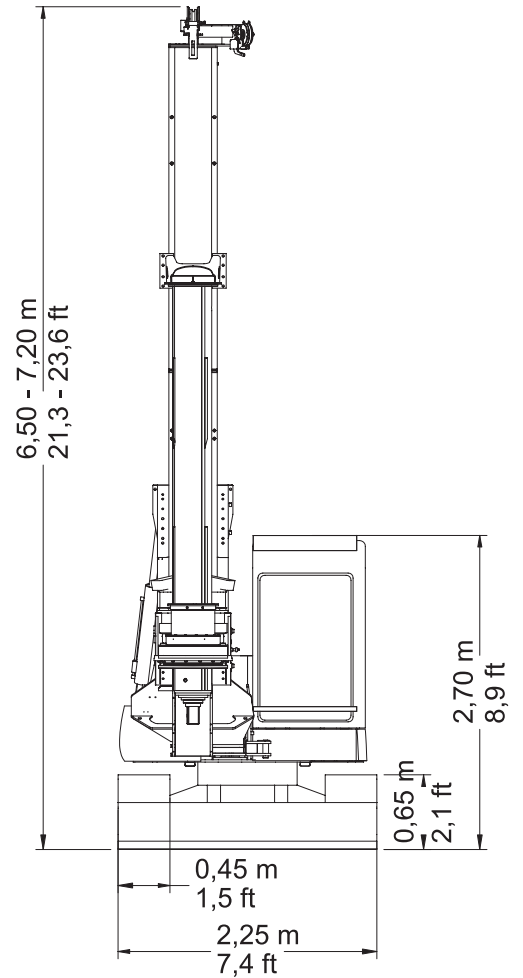
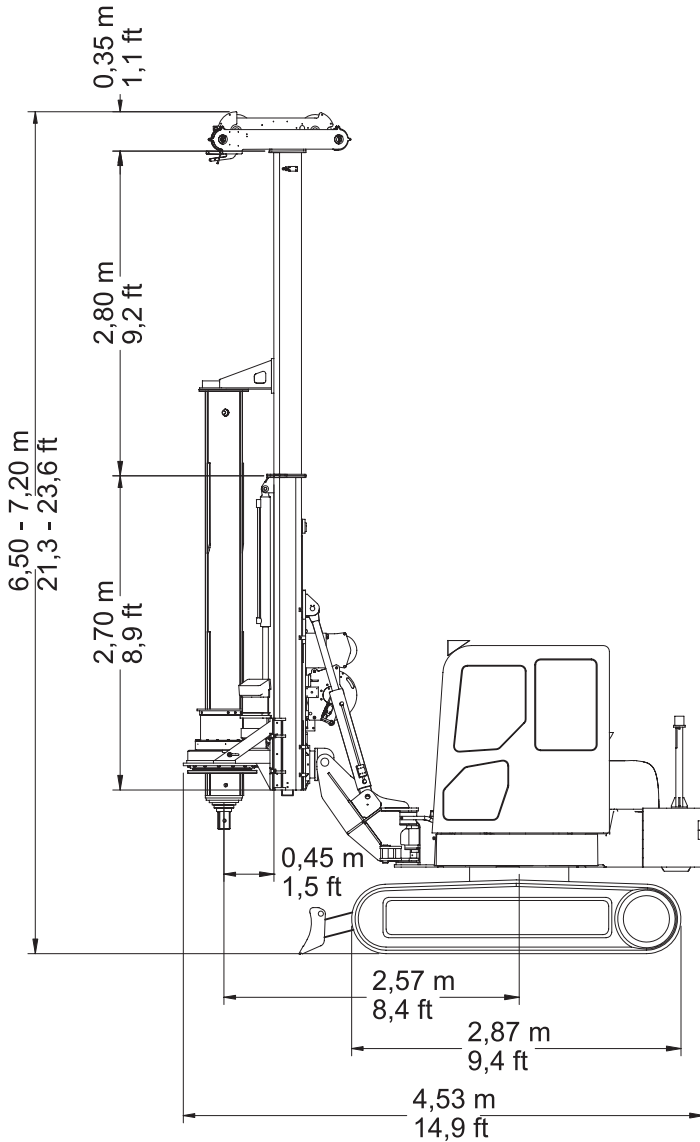

The MIDI DRILL is part of MAIT's MINI DRILL LINE. It is a compact machine with remarkable high working performance capacity. Thanks to the latest technology upgrades developed by MAIT's Technical Department, the MIDI DRILL has achieved superior characteristics to other similar machines in the same category.





### Technical Data / Données Techniques

		PC 80	
<b>Base Machine:</b>	<b>Machine Base:</b>		
<b>Diesel Engine:</b>	<b>Moteur Diesel:</b>		
Type	Type	4D98E-3ZSFB	
Installed power	Puissance	45,6 KW	61 HP
Hydraulic oil tank	Réservoir huile hydraulique	65 l	17 gal
Fuel tank	Réservoir de carburant	110 l	29 gal
<b>Rotary:</b>	<b>Tête de Rotation:</b>		
Nominal torque	Couple nominal	35 KNm	25,800 lbsft
Stroke	Course	950 mm	3.11 ft
Unloading speed	Vitesse de déchargement	84 rpm	
Nominal pullback	Traction nominale	40 KN	9,000 lbs
Nominal pulldown	Poussée nominale	30 KN	6,750 lbs
<b>Main Winch:</b>	<b>Treuil Principal:</b>		
Nominal pullback	Traction nominale	36 KN	8,100 lbs
<b>Service Winch:</b>	<b>Treuil Auxiliaire:</b>		
Nominal pullback	Traction nominale	14 KN	3,147 lbs
<b>Crawler:</b>	<b>Chenille:</b>		
Length	Longueur	2.875 m	9.4 ft
Width	Largeur	2.250 m	7.4 ft
Shoes	Semelles	450 mm	1.5 ft
<b>Approx. Weight:</b>	<b>Poids Approx.:</b>	13,1 tons	28,880 lbs

### Working Characteristics / Caractéristique de Travail

<b>Works with Augers &amp; Buckets:</b>		<b>Travaux avec Tarières et Buckets:</b>	
Depth	Profondeur	18 - 22 m	59 - 72 ft
Diameter	Diamètre	400 - 900 mm	15 - 36 in

La MIDI DRILL, qui fait partie de la série MAIT MINI DRILL, est une machine avec dimensions compacte, mais ayant aussi considérables capacités de travail.

Grâce aux dernières améliorations des technologies effectuées par le staff technique MAIT, la MIDI DRILL a rejoint caractéristiques supérieures aux machines de sa même catégorie.



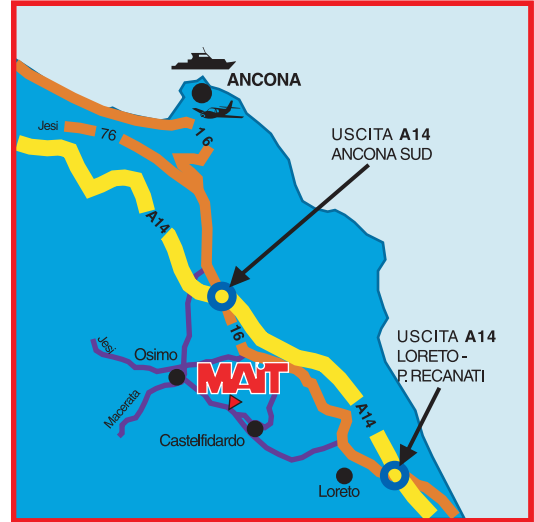

## MAIT also manufactures:

- Hydraulic drilling rigs of every size:
  - for piling, diaphragm walls, continuous flight augers;
  - for water wells;
  - for soil investigation, consolidation, civil engineering;
  - jet-grouting;
- Casing oscillator;
- Power pack;
- Casing tubes;
- Augers and buckets;
- Hydraulic grabs for diaphragm walls;
- Continuous flight auger;
- Tremie pipes;
- Drilling tools and accessories;

## MAIT produit également:

- Des équipements de forage pour:
  - palification, parois moulées, tarière continue;
  - recherche de nappes d'eau;
  - géologie, consolidations, génie civil;
  - jet-grouting;
- Louvoyeuses;
- Power pack;
- Tubes de chemisage;
- Tarières et buckets;
- Bennes pour parois moulées;
- Tarières continues;
- Tubes jet;
- Dents et piquets pour outils;



**MAIT** S.p.A. DRILLING RIGS

Via Flaminia Seconda n° 149/153

P.O. Box 1040 □ 60027 OSIMO (AN) ITALY

Tel.: +39 071 7822186 □ Fax: +39 071 780535

Web: <http://www.mait.it> □ e-mail: [info@mait.it](mailto:info@mait.it)