

EK 60



MULTI-PURPOSE PILING RIG

EK60

The GEAX EK60 is a multi-purpose piling rig designed to achieve the highest levels of versatility, ease of use, manoeuvrability, transportation, production and reliability. It is configured to operate in various different piling modes including rotary kelly piling, CFA piling and diaphragm walling. As most of the components are modular, the conversion from one mode to another is extremely simple and fast.

The GEAX EK60's outstanding production capability is comparable to machines of a much larger size. Its excellent stability allows easy manoeuvrability on job sites and ensures fast and safe operating movements. Its compactness and low weight allows easy transportation without special permits.

The Hitachi Zaxis 110LC-3 or JCB JS130LC base carrier, constructed to GEAX specifications, ensures excellent reliability and maintenance with operator cabin comfort not available on proprietary machines.

Available in two versions: standard and L (long).



The GEAX EK60 (in common with other GEAX machines) has an articulation structure similar to a normal excavator with a long boom supporting the mast. This allows a wide range of mast positioning and independent adjustment of the vertical position of the mast. Wire rope positions are not dependent on the position of the mast as the winches are mounted on the mast itself. This design, compared to other machines, usually with parallelogram type mast supports, ensures the following:

- Excellent rigidity and lightness
- More precise movements
- Fast setup time
- Wide range of tool positioning
- Simpler maintenance
- Better visibility for the operator

Electronic devices

EK series machines are equipped with an electronic system which controls and displays several functions and parameters.

- Automatic alignment of the mast
- Mast inclination display
- Depth measuring device
- Pressure gauge for an auxiliary input

A GPS system enables GEAX owners to monitor and manage their machines remotely by a PC connected to the Internet

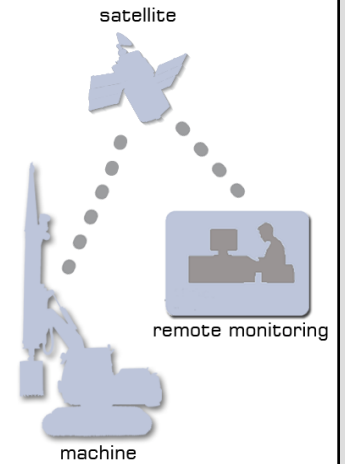
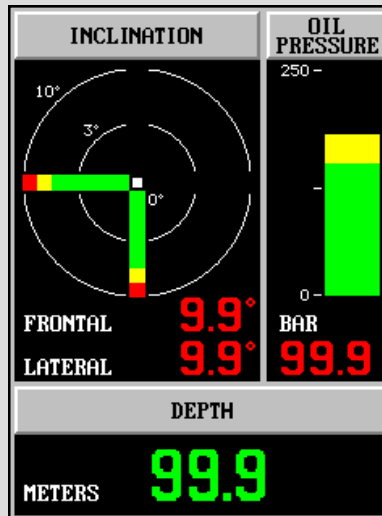

BPS patented crowd system for CFA piling

The pull-down system type BPS is GEAX's patented crowd system for CFA piling, providing a mechanical locking system between the rotary head and the mast which creates a crowd force on the auger and the crowd force is available along the entire length of the mast.

The pull-down system is activated only when needed by the operator and requires no pulleys or ropes.

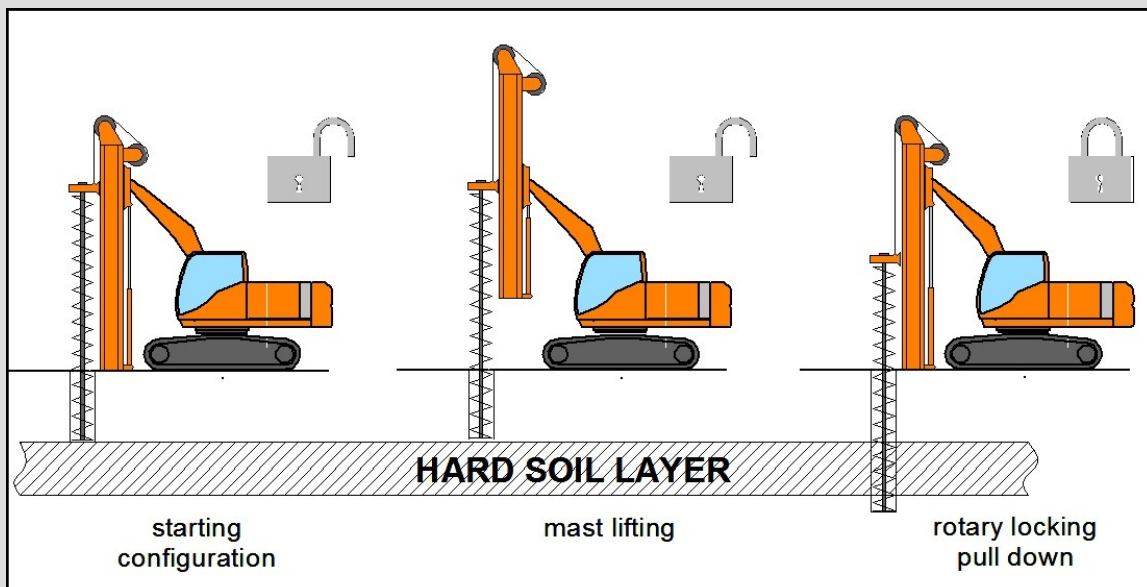
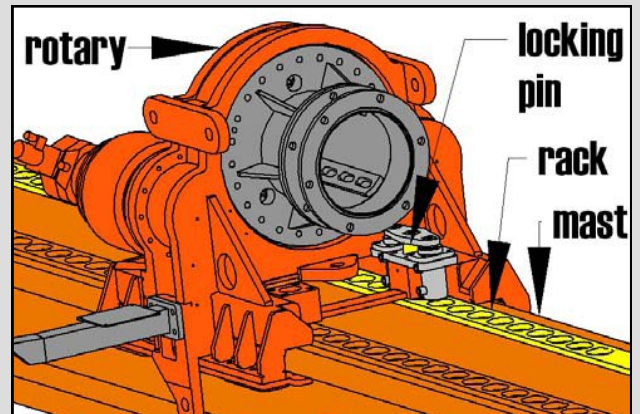

www.geax.it

info@geax.it

EK60 P

Kelly Piling

EK60 LP

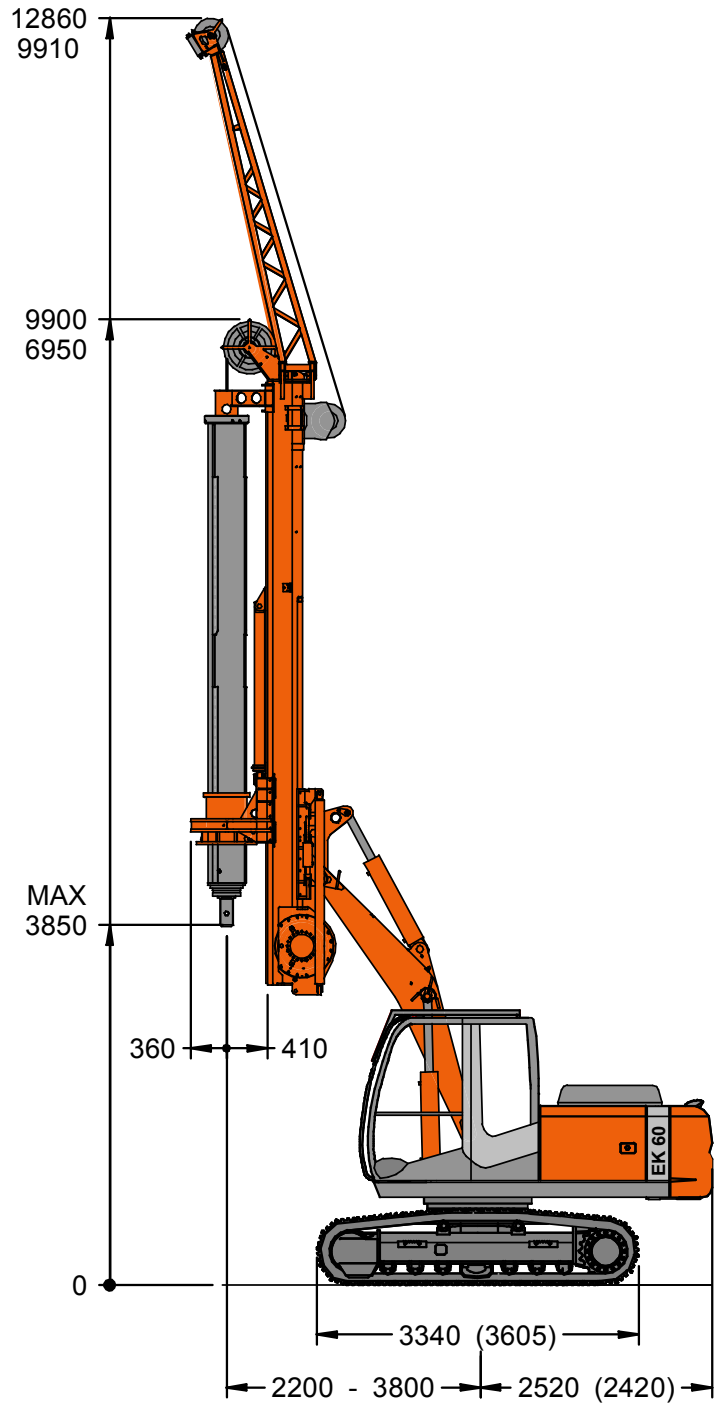
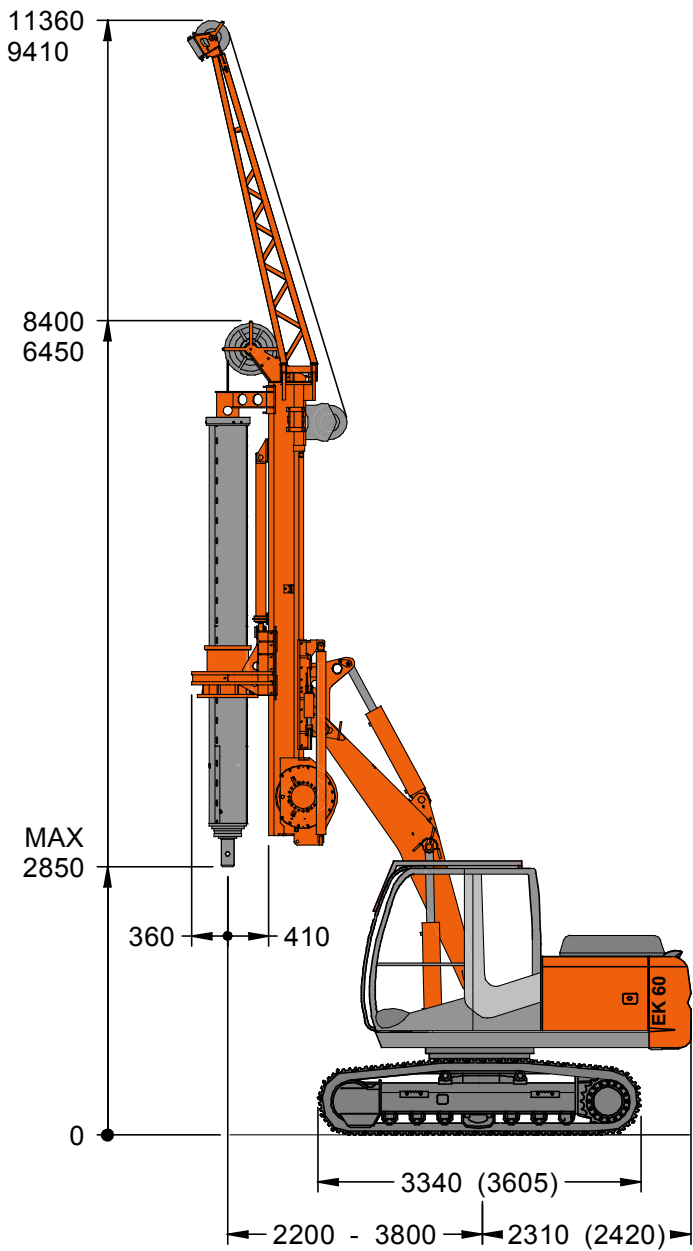

Measures referred to Hitachi (JCB) base

MULTI-PURPOSE PILING RIG

www.geax.it

info@geax.it

EK60 CFA

CFA Piling

EK60 LCFA

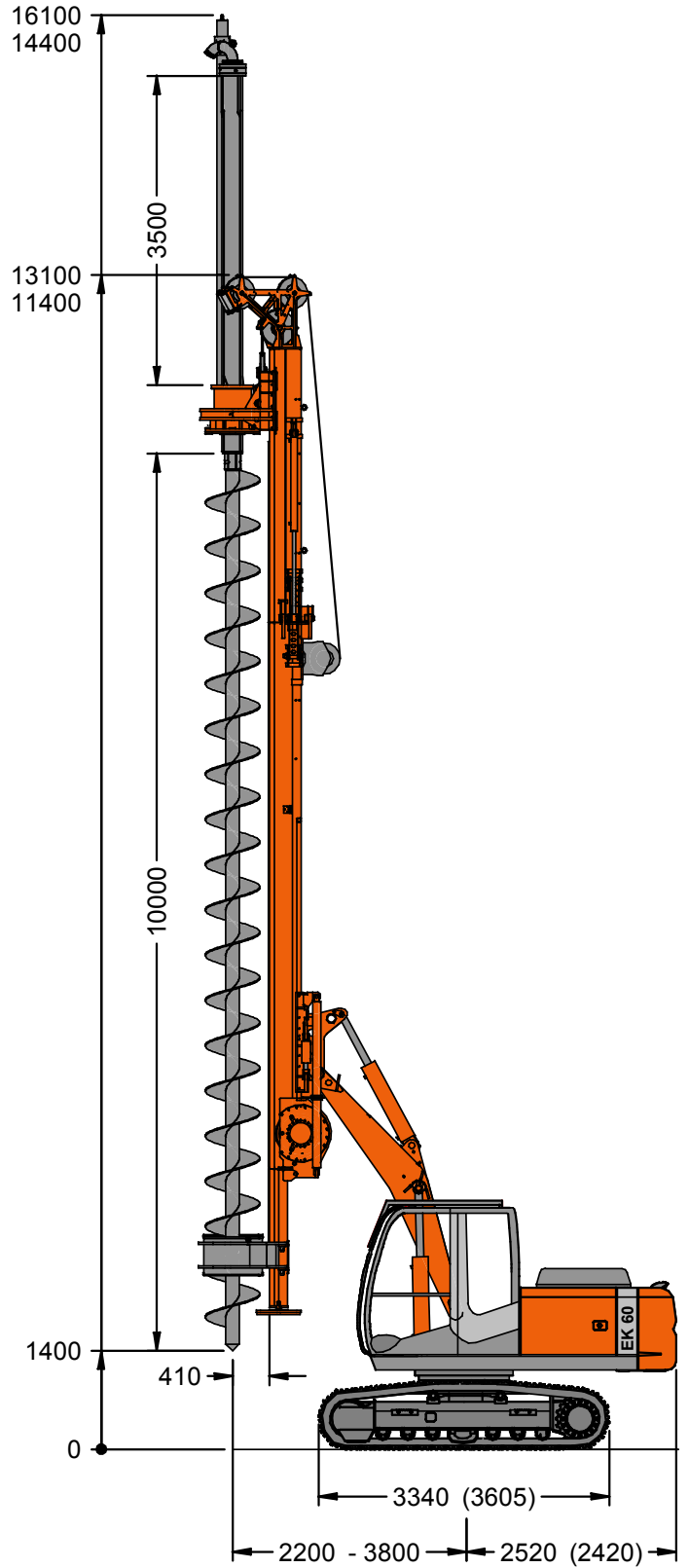
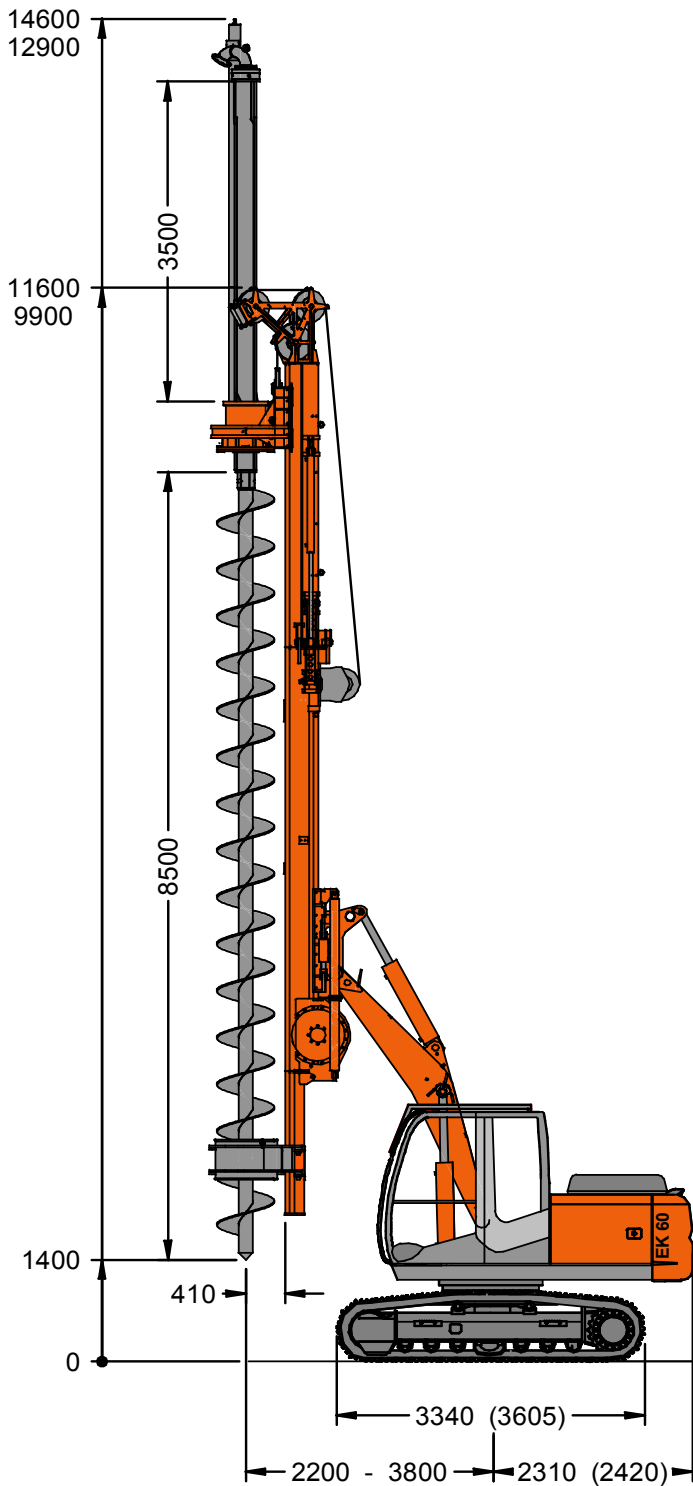

MULTI-PURPOSE PILING RIG

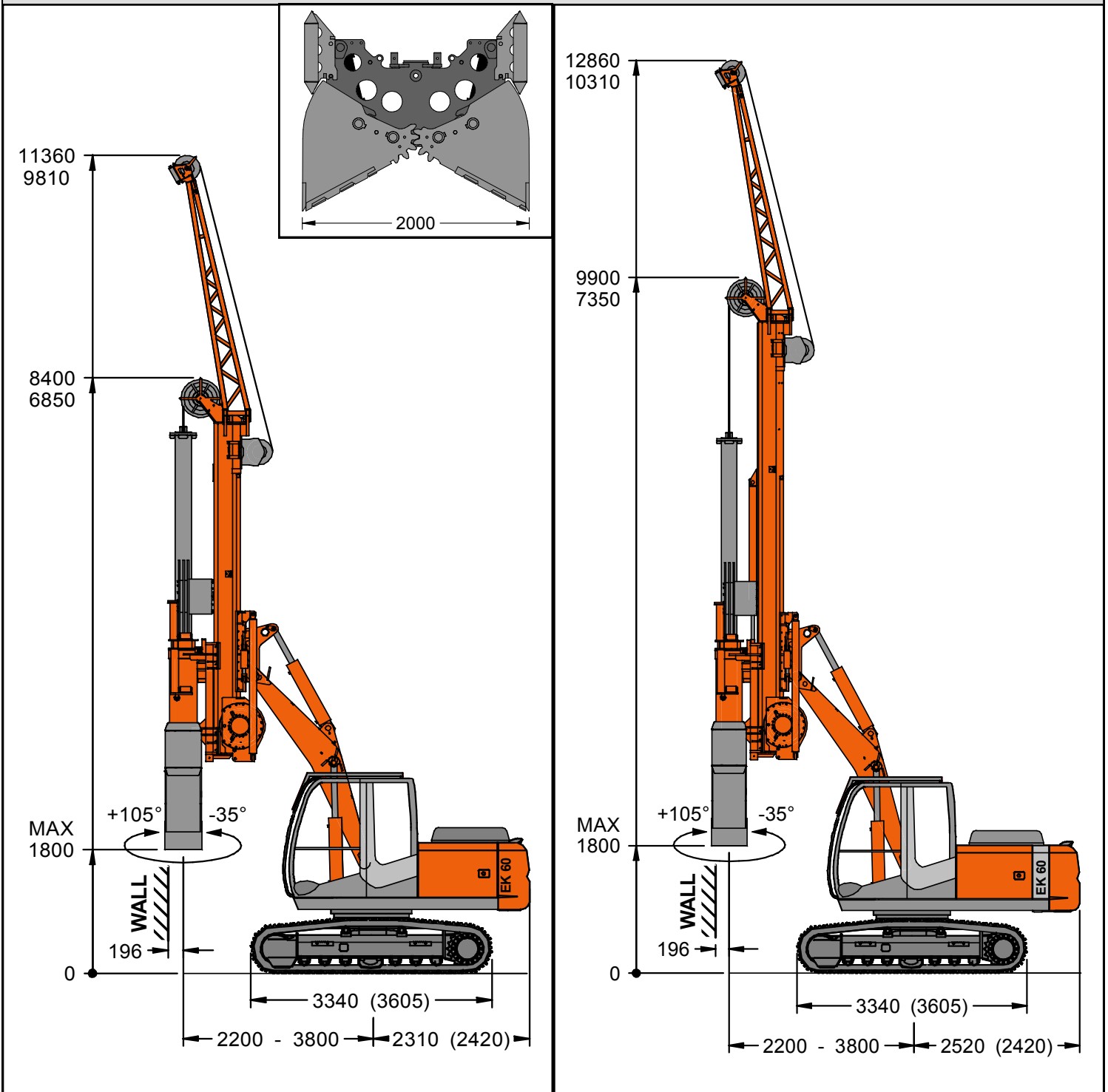

Technical features

Base HITACHI/JCB		Zaxis110LC-3 / JS130 LC		
Engine	type	ISUZU AJ-4JJ1X		
Engine power	Kw (hp)	69 (93)/ 73 (99)		
Undercarriage length	mm - ft	3340 - 11 / 3605 - 11.8		
Undercarriage width	mm - ft	2490 - 8.25		
Shoe width	mm - in	500 - 19.7		
Hydraulic system				
Main pumps	l/min	2x111/2x124		
Auxiliary pump	l/min	2x33.6/2x21		
Hydraulic pressure	bar	320		
Rotary		EK60 P/LP	EK60 CFA/LCFA	EK60 D/LD
Nominal torque	kNm - ft lbs	53 - 38,400		-
Drilling speed (3)	rpm	11÷58		-
Rotary stroke	mm - ft	3000 - 9.84	9500-31.2/1100-36	3000 - 9.84
Winches				
Main winch line pull	kN - lbs	80 - 18,000	160 - 36,000	80 - 18,000
Main winch rope diameter	mm - in	18 - 0.7		
Aux winch line pull	kN - lbs	25 - 5,600/ 30 - 6,700 (L version)		
Aux winch rope diameter	mm - in	12 - 0.47		
Crowd system				
Pull down force	kN - lbs	70-15,750/80-18,000	-/80 - 18,000	-
Extraction force	kN - lbs	180 - 40,000		
Excavation				
Max pile diameter	mm - in	1200 - 48	600 - 24	-
Max pile/wall depth	m - ft	21-69/25-82	12-39.5/13.5-44.3	16-52.5
Width of trench	mm - in	-	-	300-11.8 ÷ 600-23.6
Length of trench	mm - in	-	-	2000 - 79
Grabs closing force	kN - lbs	-	-	120 - 27,000
Grab rotation	deg	-	-	+105°÷-35°
Transport				
Length (A)	mm - ft	8400-27.5/10000-32.8	8100-26.5/9800-32.1	8400-27.5/10000-32.8
Width	mm - ft	2490 - 8.25		
Height	mm - ft	3050 - 10		
Weight	t - lbs	17-37,400/19-41,900	16-35,200/17,5-38,600	17-37,400/19-41,900

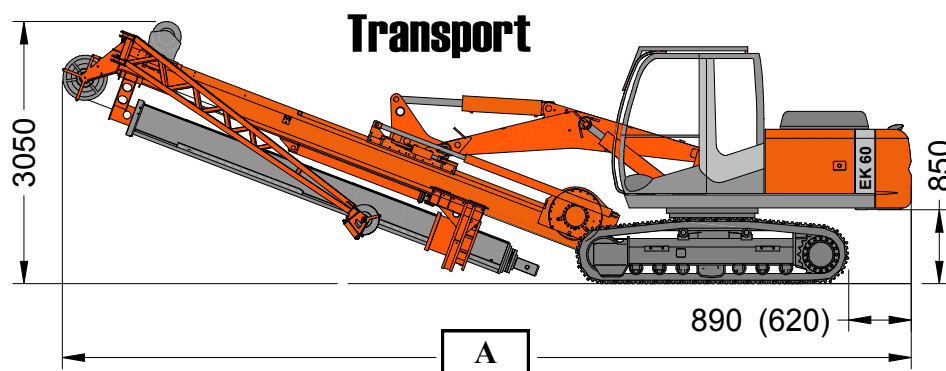



Technical specifications are subjected to change without prior notice

GEAX s.r.l.

Via Campoceraso 13 60027 Osimo (AN) Italy
tel. +390717131953 fax. +39071715199
info@geax.it www.geax.it

DEALER