

**OPERATING AND MAINTENANCE MANUAL
MODEL MB**

CATALOG NO. 3413, 115V, 50/60 Hz

3414, 230V, 50/60 Hz

3411, 115V, 50/60 Hz/275 HEAD

3412, 230V, 50/60 Hz/275 HEAD

IM-116A

February 1, 1971

 **DAMON/IEC DIVISION**
300 SECOND AVE., NEEDHAM HTS., MASS. 02194, TEL: (617) 444-6700



THE INTERNATIONAL MODEL MB CENTRIFUGE

**OPERATING AND MAINTENANCE MANUAL
MODEL MB**

1. INTRODUCTION

The Model MB centrifuge provides the medical profession with a means of providing a substantial saving in time and labor. The results are accurate, only a micro quantity of blood is necessary and the inexpensive capillary tubes can be used once and discarded, thus eliminating the cleaning of expensive glassware.

The machine is equipped for automatic operation. Turning the timer knob turns the machine on as it sets the running time. The centrifuge shuts off automatically and sounds a bell.

The unit is finished in beige, baked enamel with contrasting control panel. The 115V 50/60 Hz Model is UL and CSA approved.

2. INSTALLATION

The centrifuge, as shipped from the factory, has been tested and is ready to use as received. It is equipped with a universal motor for use on 115 volt, 50/60 Hz or 230 volts, 50/60 Hz as indicated on the data plate on the bottom of the base.

MAKE SURE THAT THE AVAILABLE ELECTRICAL SUPPLY IS OF THE VOLTAGE SHOWN ON THE CENTRIFUGE NAME PLATE.

When in operation, the minimum speed and g's are as follows:

- a) 275 head 11,500 rpm, 13,000 g

Page 2.0
IM-116A

3. OPERATING INSTRUCTIONS

3.1 Placing a Head on the Unit

If the machine is shipped without a head on the shaft, place a No. 275 head on the shaft after removing the cover. Then tighten the head lock-nut with the spanner wrench No. 30881 attached to the beaded chain.

3.2 Loading of the Head

Place the sealed capillary tubes containing the blood samples in the numbered slots in the head with the sealed end of the tube at the periphery. If the tubes are sealed with clay or plasticene, use the rubber cushion, IEC Part No. 1505. It is necessary to line the inner side of the flange of the head with the rubber cushion, making a smooth butt joint with the ends. Position the joint so that it is not opposite a groove in the head. (It will be necessary to cut off a short piece of excess material to obtain the correct length.) A thin layer of silicone grease on the outer side of the rubber will provide sufficient adhesion to hold it in place and will facilitate replacement. Occasional shifting of the rubber will be necessary as it will eventually become punctured.

When loading the head, be sure that the tubes are touching the rubber cushion, and that the ends of the tubes do not protrude into the center recess in the head where the head lock-nut fits. Spin the head by hand and observe that the tubes are properly seated.

3.3 Operation

Replace the head cover and tighten the cover nut onto the head, finger-tight. Close and latch the centrifuge cover.

Turn the timer switch on (clockwise) and then on past the desired running time, to about the 10 minute mark and return to desired setting, usually 4 to 5 minutes. When the timer switch returns to zero, a signal bell sounds and the head will coast to a stop. If faster stopping is desired press the spring-loaded brake switch and hold until the head has almost come to rest and then release. The head will reverse direction of rotation if the brake switch is held down after head stops.

When the centrifuge stops, lift the centrifuge cover and unscrew the head cover. The capillary tubes may easily be removed by tilting them at the peripheral end. They should be removed promptly and placed in a vertical position. If the head cover sticks, loosen the nut with the spanner wrench, IEC Part No. 30881, furnished with the machine. Keep the interior of the head free from abrasive material such as broken glass particles and spilled blood to avoid excessive vibration. Be careful of possible corrosion.

4. GUARANTEE

International centrifuges and accessories are guaranteed against defective materials and workmanship for a period of one year from the date of their receipt, provided that the equipment is used according to International Equipment Company recommendations. The basic recommendations are as follows:

-
- 4.1 Maintenance requirements as indicated in Section 6 of this manual must be carried out.
 - 4.2 The centrifuge owner should not use IEC centrifuge accessories on centrifuges manufactured by others and IEC does not recommend the use of another manufacturers' accessories on their centrifuges. Such use of the products would naturally nullify the IEC guarantee and absolve IEC from normal manufacturer's product liability.

5. OPERATION OF READERS

5.1 Illuminated Micro-Capillary Tube Reader, Model CR, No. 2202

The following method is used to operate the Model CR reader. Swing the magnifier up and out of the way.

- a) Loosen the lock-nut on the right end of the scale and move the scale to the top of the arc and lock in place. This will give room to load the capillary tube.
- b) Move the Lucite tube holder to the 100 position on the scale. (Always move the tube holder slide by grasping the two black-rubber grips.)
- c) Place the capillary tube in the V-slot of the Lucite holder with the sealed end down, and in contact with the stop on the holder.

- d) Then loosen the lock-nut on the scale and move the scale down as far as it will go and lock in place.
- e) Drop the magnifier down into a reading position.
- f) Turn the knurled adjustment screw located at the bottom of the holder until the bottom edge of the red cells lies directly under the edge of the scale.
- g) Again loosen the lock-nut on the scale. Move the scale and tube holder simultaneously until the left edge of the plasma meniscus meets the 100 mark on the scale. Lock the scale in place.
- h) Move the tube holder to the left until the left edge of the red blood-cell meniscus meets the edge of the scale.
- i) Read the hematocrit at this point in percentage directly from the scale.

5.2 Circular Micro-Capillary Tube Reader, No. 2201

The following method is used to operate the circular reader.

- a) Place the centrifuged capillary tube in the groove of the plastic indicator so that the bottom of the column of red cells coincides with the black line near the center on the plastic indicator.
- b) Rotate the bottom plate so that the 100 per cent line is directly beneath the red line on the plastic indicator; then hold the bottom plate in this position. Now, using the finger-hole, rotate the top plate so that the spiral line intersects the capillary tube at the plasma-air interface.
- c) Rotate both discs together until the spiral line intersects the capillary tube at the red-cell white-cell interface.
- d) The hematocrit is read in percentage from the point on the scale directly beneath the red line on the plastic indicator. *NOTE: The design of the plastic indicator is such that when the eye of the person reading is in the correct location, the spiral line appears continuous as it passes beneath the plastic indicator. Should the spiral line appear broken, then the reader should re-adjust his position until the line appears continuous.*

6. MAINTENANCE OF MODEL MB

6.1 Lubrication

No lubrication is necessary as the motor is equipped with lubricated sealed bearings.

6.2 Brushes

The brushes, IEC Part No. 43653, should be examined every 2 months under normal conditions. Remove the three screws from the underside of the base plate, unscrew the motor brush caps and remove the brushes. Replace them if they are worn to less than 5/16-inch.

6.3 Removing the Head

~~To remove the centrifuge head, unscrew the head cover and, using the spanner wrench supplied with the machine, loosen and remove the head lock nut. The head may then be removed from the motor shaft.~~

6.4 Latch Adjustment

A nylon adjustment screw has been incorporated into the latch to compensate for gasket compression. Periodically, this screw should be checked and adjusted to maintain a snug fit of the latch to prevent air leakage around the gasket.

In order to adjust:

- a) Raise the cover.
- b) Remove the set screw from the bottom of the latch.
- c) Tighten adjusting screw a slight amount and check adjustment. *NOTE: When properly adjusted, the cover when closed will compress the gasket slightly. Also, the latch will be snug when locked.*
- d) Reinstall the set screw.

If latch is snug but a gap still exists between the gasket and the cover when closed, the gasket must be replaced.

Page 6.0
IM-116A

REFERENCE DWGS.

C 10277

3

NEXT ASSEMBLY A3411-PN3412

THIS DRAWING IS CONFIDENTIAL AND THE PROPERTY OF INTERNATIONAL EQUIPMENT COMPANY AND MAY NOT BE REPRODUCED IN ANY FORM WITHOUT THE WRITTEN CONSENT OF THE OWNER.

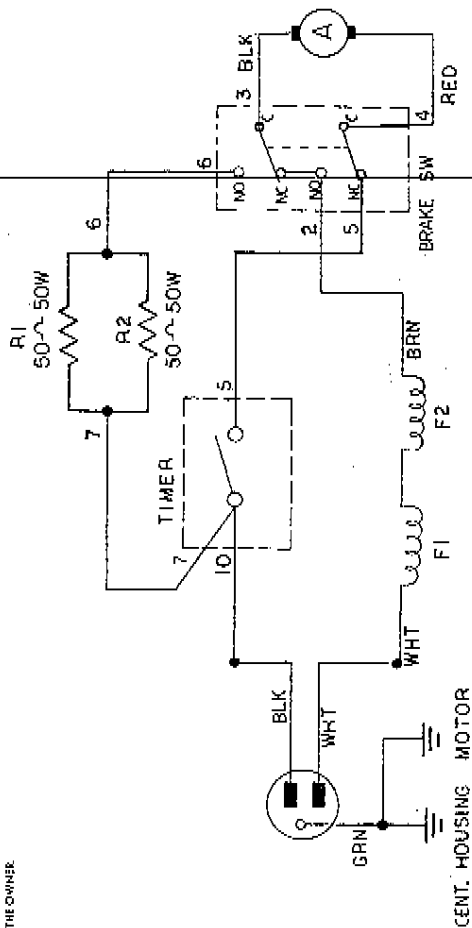

CENT. HOUSING MOTOR

REV	0	DATE	8/21/85	DESCRIPTION	ECN
BY		APPROVED			
RELEASED PER		THIS ECO. AS			7135
REQUIRED ON		REGO. TO			
APPROVAL		APPROVAL			

PART NO.		NONE
UNLESS OTHERWISE SPECIFIED		
ALL COPERS & PALLETS TO BE		
2031 TO .031 RADII		
DIMENSIONS ARE IN INCHES		
SURFACE FINISH		
UNLESS OTHERWISE SPECIFIED		
SEE TO SPEC. D02, D05, D06		
MATERIAL		
NONE		
FINISH		
NONE		

TITLE		SCHEMATIC	
MODEL		MODEL MB WITH	
JONES		MOTROLA MOTOR	
BY	DATE	INTERNATIONAL	
DRAWN BY	8/21/85	EQUIPMENT COMPANY	
CHECKED BY	8/21/85		
APPROVED BY		DRAWING NO.	C-10277
SCALE	NONE	REV	0

USED ON	
APPLICABLE SPECIFICATIONS	

TOLERANCE OF FARKKATED PARTS AND WELDMENTS UNLESS OTHERWISE NOTED:
 10" TO 18" .125
 3/4" TO 10" .015
 36" TO 48" .010
 TOLERANCE ON HOLE TO HOLE RELATIONSHIP .015

THIS PRINT MADE	
SHEET 1 OF 1	3

Page 8.0
IM-116A7. PARTS LIST

<u>Unit</u>	<u>Description</u>	<u>IEC Part No.</u>
(1)	Vent Screen	30900
(2)	Acorn Nut, ¼ - 20 - NC - 2 (2)	50
(3)	Headless Slotted Screw, Cone Pt. ¼ - 20 - NC - 2 x 7/8 inch (2)	50
(4)	Butt Splice, API #34070	50
(5)	Cover Knob	7913
(6)	Friction Washer	30897
(7)	Lock Nut	30894
(8)	Drive Stud (2)	7954
(9)	Head	275
(10)	Cushion	1505
(11)	Gasket	1511
(12)	Faston Terminal, API #41274	50
(14)	Brake Resistor Assembly	41313
(15)	Jumper Wire	42413
(16)	Wire Head Assembly	42287
(17)	Faston Connector, API #41450	50
(18)	Wire Load Assembly	43763
(19)	Stud	30898
(20)	Hex Nut Metal Cap, ESNA #22 K2-02	50
(21)	Hex Nut, #10-32 NF-2 (3)	50
(22)	Lock Washer, Shakeproof #10 (2)	50
(23)	Wire Lead Assembly	43764
(24)	Insulation Bushing	9660
(25)	Screen	30889
(26)	Face Spanner Wrench	30881
(27)	Bead Chain Coupling, Bead #10 AD, Type A (2)	30901
(28)	Truss Head Slotted Screw, #10-32-NF-2 x ½" long (3)	50
(29)	Cord Set, 115 volt	38805
	Cord Set, 230 volt	38806

Page 10.0
IM-116A

<u>Unit</u>	<u>Description</u>	<u>IEC Part No.</u>
(30)	Washer, .130" ID x 1" OD x 3/64" thick (4)	42125
(31)	Washer, .130" ID x 1/2" OD x 3/64" thick (4)	42126
(32)	Pop Rivet, SD 48 BS (4)	50
(33)	Bead Chain, 14" long	7907
(39)	Vibration Dampener (4)	1884
(42)	Washer (4)	1885
(43)	Washer (6)	30888
(44)	Base Plate	30877
(45)	Timer	768
(46)	Motor, 115V, 50/60 Hz	<i>1875</i> 43888
	Motor, 230V, 50/60 Hz	<i>1876</i> 43889
(48)	Slotted Set Screw, 5/16-18-NC-2 x 1/4" long	50
(49)	Nylon Set Screw	7932
(50)	Sleeve Spacer (3)	30882
(52)	Latch Pin	30887
(53)	Latch Pin	30878
(54)	Lock Nut (3)	
(55)	Flat Head Slotted Screw 1/4-20 NC 2 x 1 1/4" (3)	50
(57)	Head Adapter	7915
(59)	Disk Cover	7912
(60)	Retaining Ring	50
(61)	Cover	30875
(62)	Base	30876
(63)	Control Panel	43728
(64)	Switch Double Pole, Double Throw	42958
(65)	Pointer	30839
(67)	S-Hook	30902
(68)	Fiber Glass Liner	31674
(69)	Insulation	31675
(71)	Serial Data Plate	41240
(72)	Round Head Drive Screw, Parker-Kalon #0 x 3/16"	50
(74)	Motor Dampener (3)	30992
(75)	Round Head Slotted Screw, #8-32 UNC-2A x .25 lg	50

Page 11.0
IM-116A

<u>Unit</u>	<u>Description</u>	<u>IEC Part No.</u>
(76)	Spring Lockwasher 1/4"	50
(78)	Ground Head Assembly	33790
(79)	Strain Relief, Heyco, SR-6L-1	50
(81)	Plate Adaptor Cord	38803
(82)	Switch	42958
(83)	Face Nut, Knurled	42011
(84)	Screw Pan Hd, J-40 UNC-2A x .3819	

Motor PartsArmature, 115V
230V~~42011~~ 7937~~42011~~

Bearing (2)

~~42011~~

Brush Assembly

~~42011~~

Brush Holder and Cap

~~42011~~