



## **H-18SV**

2001, rev d

### ***THANK YOU,***

On behalf of everyone at **HYD-MECH**, I would like to thank and congratulate you on your decision to purchase a **HYD-MECH** band saw.

Your new machine is now ready to play a key role in increasing the efficiency of your operation, helping you to reduce cutting costs while boosting quality and productivity.

To ensure you are maximizing the power and versatility of your new **HYD-MECH** band saw, please take the time to familiarize yourself and your employees with the correct operation and maintenance procedures as outlined in this manual.

We sincerely appreciate the confidence you have demonstrated in purchasing our product and look forward to building a long and mutually beneficial relationship.

Thank-you.

**HYD-MECH GROUP LIMITED**  
P.O. BOX 1030, 1079 Parkinson Road  
Woodstock, Ontario Canada, N4S 8A4  
Phone: (519) 539-6341  
Service 1-877-237-0914  
Sales 1-800-276-SAWS(7297)  
Fax (519) 539-5126  
e-mail, [info@hydmech.com](mailto:info@hydmech.com)



*The Rock Solid Solution*

---

---

# H-18SV Table of Contents

## **SECTION 1, INSTALLATION**

SAFETY PRECAUTIONS .....	1
H-18 & H-22 LIFTING INSTRUCTIONS .....	2
FOUNDATION, LEVELLING AND ANCHORING .....	3
WIRING CONNECTIONS .....	4
HYDRAULIC OIL AND CUTTING FLUID .....	4

## **SECTION 2, OPERATING INSTRUCTIONS**

BLADE BASICS .....	5
VARIABLE SPEED CONTROL .....	5
THE CONTROL PANEL .....	6
START-UP .....	6
MANUAL OPERATION .....	6
OPERATOR PANEL SWITCHES .....	7
PLC 100 CONTROL SYSTEM .....	9
OPERATION OVERVIEW .....	9
ACTIVATING THE PLC .....	10
PLC CONTROL PANEL .....	10
FUNCTION KEY DESCRIPTIONS .....	11
MANUAL MODE FUNCTION KEY DESCRIPTIONS .....	11
MITSUBISHI PLC 100 CONTROL SYSTEM .....	11
OPERATION OVERVIEW .....	11
SINGLE PART CYCLE OPERATION .....	12
KERF CORRECTION .....	12
AUTOMATIC OPERATION .....	13
PROCEDURE FOR EDITING OR STARTING A NEW JOB IN AUTO MODE .....	13
WORKING WITH A QUEUE .....	14
HYDRAULIC FEED CONTROL .....	15
CUTTING PARAMETERS CHART .....	15
CHART EXAMPLE #1 .....	16
STEP 1, DETERMINE EFFECTIVE MATERIAL WIDTH - W ( inches ) or (mm) .....	16
STEP 2, SET FEED FORCE LIMIT .....	16
STEP 3, DETERMINE OPTIMUM BLADE PITCH - TEETH PER INCH (T.P.I.) .....	17
STEP 4, DETERMINE OPTIMUM BLADE SPEED, V (ft/min) (m/min) .....	17
STEP 5, DETERMINE FEED RATE SETTING, FR (in/min) (mm/min). .....	18
ADDITIONAL CUTTING SETUP EXAMPLES .....	19
ADDITIONAL CONTROLS .....	20
COOLANT FLOW .....	20
HEAD UP and DOWN LIMIT SETTING .....	20
BUNDLING OPERATION (OPTION) .....	21
VARIABLE VISE PRESSURE (OPTION) .....	21

## **SECTION 3, MAINTENANCE AND TROUBLE SHOOTING**

LOCK OUT and PROCEDURE .....	23
BLADE CHANGING PROCEDURE .....	24
BLADE BRUSH ADJUSTMENT .....	24
BLADE TRACKING ADJUSTMENT .....	25
IDLER WHEEL TRACKING .....	25
DRIVE WHEEL TRACKING .....	25
CAM FOLLOWER ADJUSTMENT .....	25
H-18 HYDRAULIC CARBIDE SETUP PROCEDURE .....	26
LUBRICATION .....	27
HYDRAULIC MAINTENANCE .....	28
CLEANLINESS .....	28

--- Continued ---

TRUBLESHOOTING .....	29
PROGRAMMABLE LOGIC CONTROL, MITSUBISHI 100 .....	31
PLC 100 PARAMETERS .....	32
PLC 100 TROUBLESHOOTING .....	34
PLC IS NOT MEASURING LENGTHS. ....	34
INACCURATE LENGTHS IN AUTO MODE. ....	35
INCONSISTENT INACCURACY .....	35
CONSISTENT INACCURACY .....	36
LINEAR INACCURACY .....	36
AUTO CYCLE NOT BEING COMPLETED .....	37
FUSES .....	38
NO DISPLAY .....	38
NO BLADE SPEED DISPLAY. ....	38
MITSUBISHI 100 INPUTS & OUTPUTS .....	39
INPUT / OUTPUT TERMINAL INFORMATION .....	40
ENCODER and PROXIMITY SENSOR CONNECTIONS .....	40
CALIBRATION PROCEDURE .....	41
HEAD HEIGHT CALIBRATION PROCEDURE .....	42
SERVICE RECORD & NOTES .....	42

#### **SECTION 4, ELECTRICAL SYSTEM**

GENERAL INFORMATION .....	45
INITIAL HOOK-UP .....	45
ELECTRICAL COMPONENTS, PHOTOS .....	46
ELECTRICAL COMPONENTS LISTS .....	47
ELECTRICAL SCHEMATIC and WIRING DRAWINGS .....	51

#### **SECTION 5, HYDRAULIC SYSTEM**

HYDRAULIC COMPONENT PARTS LIST .....	59
CYLINDER ASSEMBLIES .....	60
Gland assemblies .....	60
Piston assemblies .....	60
HYDRAULIC SCHEMATIC and PLUMBING DRAWINGS .....	61

#### **SECTION 6, MECHANICAL ASSEMBLIES**

H-18 BLADE BRUSH ASSEMBLY .....	63
H-18 GUIDE ARM ASSEMBLY .....	64
HYDRAULIC CARBIDE GUIDE ASSEMBLY .....	65
ANTIVIBRATION ROLLER ASSEMBLY .....	66
H-18 IDLER WHEEL ASSEMBLY .....	67
HYDRAULIC PUMP ASSEMBLY .....	68
HYDRAULIC TANK ASSEMBLY .....	69
FRONT VISE ASSEMBLY .....	70
SHUTTLE VISE ASSEMBLY .....	71
SHUTTLE VISE DATUM LINE JAW ASSEMBLY .....	72
CHIP AUGER ASSEMBLY .....	73
H-18 DRIVE ASSEMBLY .....	74

#### **SECTION 7, OPTIONS**

H-18 & H-22 BUNDLING ASSEMBLY .....	75
H-18 & H-22 OUTBOARD BUNDLING ASSEMBLY .....	76

#### **SECTION 8, SPECIFICATIONS**

SPECIFICATIONS .....	77
H-18 LAYOUT .....	78

#### **SECTION 9, WARRANTY**

WARRANTY .....	79
MITSUBISHI PLC 100 (FX2n48MR) PARAMETERS .....	80

---

## **SECTION 1, INSTALLATION**

Upon delivery of your new H-18 saw, it is imperative that a thorough inspection be undertaken to check for any damage that could have been sustained during shipping. Special attention should be paid to the electrical and hydraulic systems to check for damaged cords, hoses and fluid leaks. In the event of damage caused during shipping, contact your carrier to file a damage claim.

### **SAFETY PRECAUTIONS**

The H-18 has been designed to give years of reliable service. It is essential that operators be alerted to the safe operation of this saw, and the practices to avoid that could lead to injury. The following safety rules are at the minimum necessary for the safe installation, operation, and maintenance of the saw. Take every precaution for the protection of operators and maintenance personnel.

POWER HOOK-UPS AND REPAIRS SHOULD BE ATTEMPTED ONLY BY QUALIFIED TRADESMEN.

THE SAW SHOULD BE LOCATED IN AN AREA WITH SUFFICIENT ROOM TO SAFELY LOAD STOCK INTO THE SAW. SECURE THE SAW TO THE FLOOR.

THE AREA AROUND THE SAW SHOULD BE MAINTAINED IN A CLEAN AND TIDY CONDITION TO AVOID OBSTACLES OPERATORS COULD TRIP OVER.

THE H-18 SHOULD ONLY BE OPERATED ACCORDING TO THE SPECIFICATIONS OF THE SAW. AVOID UNSAFE USAGE PRACTICES.

IF AT ANY TIME THE SAW DOES NOT APPEAR TO BE OPERATING PROPERLY IT SHOULD BE STOPPED IMMEDIATELY AND REPAIRED.

*OPERATOR* : THE SAW SHOULD NEVER BE OPERATED UNLESS ALL GUARDS AND DOORS ARE IN PLACE AND CLOSED.

*OPERATOR* : KEEP A SAFE DISTANCE FROM ALL MOVING PARTS - ESPECIALLY THE BLADE AND VISES.

*OPERATOR* : LOOSE CLOTHING AND GLOVES SHOULD NEVER BE WORN WHILE OPERATING THE SAW. COVER LONG HAIR.

*OPERATOR* : STOCK SHOULD NOT BE LOADED ONTO THE SAW IF THE BLADE IS RUNNING.

*OPERATOR* : LONG AND HEAVY STOCK SHOULD ALWAYS BE PROPERLY SUPPORTED IN FRONT OF AND BEHIND THE SAW.

*OPERATOR* : NEVER ATTEMPT TO DISLodge OR MOVE STOCK WHILE THE BLADE IS MOVING. TAKE THE TIME TO STOP THE SAW BLADE, REMOVE OBSTRUCTIONS, AND RESTART BLADE.

*OPERATOR* : MUST WEAR EYE PROTECTION.

*OPERATOR* : MAINTAIN PROPER ADJUSTMENT OF BLADE TENSION, BLADE GUIDES, AND BEARINGS

*OPERATOR* : HOLD WORKPIECE FIRMLY AGAINST TABLE.

*OPERATOR* : DO NOT REMOVE JAMMED CUTOFF PIECES UNTIL BLADE HAS STOPPED.

**NO MODIFICATIONS TO THE MACHINE ARE PERMITTED WITHOUT PRIOR APPROVAL FROM HYD-MECH. ANY APPROVED MODIFICATIONS SHOULD ONLY BE UNDERTAKEN BY TRAINED PERSONNEL.**

# H-18 & H-22 LIFTING INSTRUCTIONS

THE H18 AND H22 ARE DESIGNED TO BE LIFTED IN ONE FULLY ASSEMBLED PIECE IN ORDER TO LIFT THE MACHINE, THE FOLLOWING CONDITIONS MUST EXIST

1. SAW HEAD IN ITS BOTTOM POSITION.
2. SHUTTLE VISE MOVED TO FATHEREST REAR POSITION.
3. BUNDLING ON BOTH VISES COMPLETELY CLOSED.
4. COOLANT TANK EMPTY.

AN EXPERIENCED RIGGER SHOULD SELECT RIGGING BASED ON THE WEIGHT OF THE SAW.

1. H18 8,500 LB
2. H22 12,500 LB

LOADING AND UNLOADING INSTRUCTIONS

1. ATTACH CHAINS 1 AND 2 TO LIFTING EYES AT TOP OF POSTS.

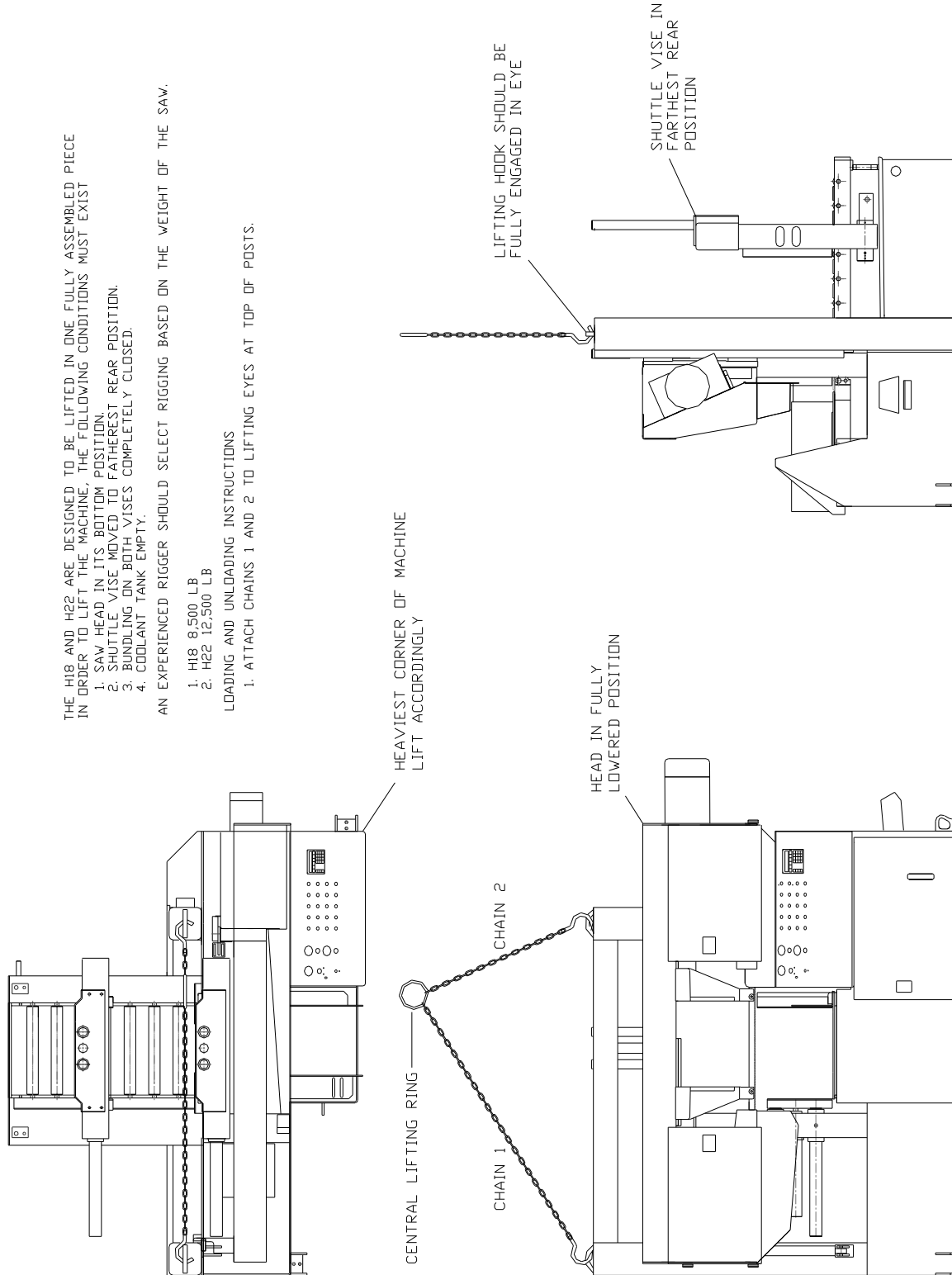

---

## ***FOUNDATION, LEVELLING AND ANCHORING***

Machine location should be carefully selected. A flat concrete floor area should be chosen. It should have enough free space surrounding the machine to enable free access for safe operation and maintenance.

Machine should be levelled in both directions ie. along and across its infeed conveyor specially when machine is to be inserted into a larger conveyor system.

Five levelling screws are provided, one in each corner of the machine base. Steel plates are to be placed under each screw to prevent their sinking into the concrete floor. In cases when machine is to be anchored permanently, anchoring holes are provided. They are located next to the levelling screws.

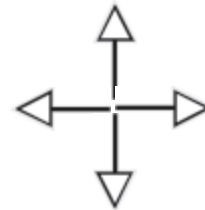

**Use a precision level in both directions on the infeed conveyor.**

**NOTE:** In some cases levelling the saw infeed and auxiliary conveyor with a slight slope towards blade is recommended. This will prevent coolant from running down the raw stock. (This is especially true when cutting tubing or bundles).

---

## **WIRING CONNECTIONS**

After the machine is levelled and anchored the necessary power hook-up needs to be performed. In order to provide safe operation as well as to prevent potential damage to the machine, only qualified personnel should make the connections.

### **BEFORE START-UP THE FOLLOWING TWO POINTS SHOULD BE CHECKED:**

- signs of damage that may have occurred during shipping to the electrical cables and the hydraulic hoses.
- the hydraulic oil level is between the upper and lower lines on the level gauge.

As supplied, the machine is set to run on three phase voltage as indicated on the serial plate and voltage label. Power connection to the machine is made to L1, L2, L3 and Ground terminals in the main disconnect box. For machines equipped with a variable frequency drive unit, an earth ground is also recommended.

During the initial hook-up it is very important to check that the phase order is correct. This is indicated by the hydraulic pressure gauge registering a pressure rise and the blade running in a counter clockwise direction. If the hydraulics do not register an immediate pressure rise, shut the hydraulics off and change the phase order.

**ATTENTION:** Running the hydraulics "backwards" can damage the hydraulic pump.

**L1, L2, L3  
Terminals**

**Ground  
Clamp**

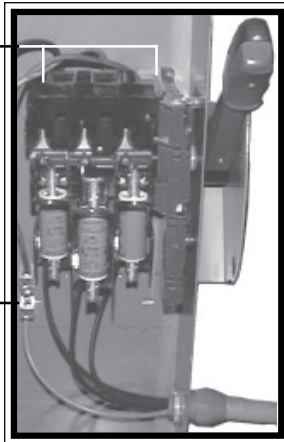

**Disconnect box connections.**

## **HYDRAULIC OIL AND CUTTING FLUID**

The H-18 bandsaw is supplied with Arco Duro 46 hydraulic oil. If it is necessary to change the oil to a different brand see the SECTION 5 for an equivalent grade oil.

No cutting fluid is supplied with the machine. There are two types of coolant available:

- oil based; dilute 1:10 ratio (one part concentrated coolant to 10 parts water)
- synthetic; dilute as recommended by the manufacturer.

---

## **SECTION 2, OPERATING INSTRUCTIONS**

This section has been prepared to give the operator the ability to set up the saw for most cutting situations. Before cutting any material, the operator should be familiar with all operations and controls as well as the basic cutting theory described below. The saw is equipped with a variable blade speed control and hydraulic feed control, as well as an extensive door chart to guide the operator to the correct setting of these controls.

### **BLADE BASICS**

Technology is rapidly changing all aspects of production machining. Metal cutoff is no exception. The advances made in the bandsaw blade industry have definitely brought down the cost per cut, despite the three fold higher price of high technology blades. Variable pitch, bi-metal blades (like the 4/6 or 3/4 bi-metal blade supplied with the machine) last much longer, cut faster, and more accurately than conventional carbon steel blades. In order to take advantage of the superiority of bi-metal blades, it is critical to properly “break-in” a new blade. This is accomplished by taking two or three cuts through solid four or five inch diameter mild steel at an *extremely slow feed rate*. (It is also advisable to utilize a slow blade speed.)

These two or three slow cuts sufficiently lap (polish) the teeth on the new blade so that it does not snag the material being cut. Proper break-in will alleviate blade vibration, improve surface finish, accuracy, and blade life.

After “break-in”, the following six points must be closely monitored to ensure long blade life:

1. Proper blade tension should be maintained. (see Section 3, Maintenance and Troubleshooting)
2. Generous coolant application is essential with most materials. A high quality and well mixed coolant will extend blade life, and also increase cutting rate and quality. On those materials where coolant is undesirable for cutting, a slight coolant flow or periodic oiling of the blade is necessary to prevent the blade from being scored by the carbide guides.
3. The stock being cut must be securely clamped in the vises.
4. The proper feed force should be chosen. (see Saw Cutting Parameters: Step 2)
5. The proper blade speed must be selected. (see Saw Cutting parameters: Step 4)
6. The proper feed rate must be applied. (see Saw Cutting Parameters: Step 5)

### **VARIABLE SPEED CONTROL**

Blade speed can be adjusted infinitely between 60 to 350 SFM (Surface Feet/Minute) (18 to 107m/min). Adjustment should be made only when the blade is running. Clockwise rotation of the knob increases blade speed while counter clockwise rotation decreases blade speed.



---

## THE CONTROL PANEL

### START-UP

The H-18 control console has been designed to simplify the operation of the saw, to give the operator the ability to stop any function at any time, and to be able to control all the functions remotely. We can not overstress the importance of familiarizing yourself with the controls of the H-18 prior to starting the machine.

- NOTE:**
- 1) ALL SWITCHES MUST BE IN THE CENTER NEUTRAL POSITION TO START THE MACHINE!
  - 2) WHEN STARTING THE MACHINE FOR THE FIRST TIME *MAKE SURE* THAT BLADE IS MOVING IN A *COUNTERCLOCKWISE DIRECTION*, AND THAT THE HYDRAULIC PRESSURE IS 1000 PSI (6890kP). IF THERE IS NO IMMEDIATE PRESSURE, SHUT THE SAW DOWN AND CHANGE THE PHASE ORDER AS STATED ON Pg. 4.



**Operator Control Console.**

## MANUAL OPERATION

Manual Operations can be performed when the PLC 100 controller is set to MAN (AUTO is active when a RED light is on above the AUTO/MAN button). All functions are self-explanatory. Specific control button functions are described on the following pages.

## OPERATOR PANEL SWITCHES

### TOP ROW



**FRONT VISE** - This switch has three positions, OPEN, HOLD and CLOSE. With the switch held in the OPEN position the vise will open all the way or until the switch is released. With the switch in the HOLD position, the vise will stay where it is and will not move freely although it will not resist a large force indefinitely without creeping. In CLOSE, the vise will close all the way, or until it encounters enough resistance to stop it.



**HEAD CONTROL** - This switch has three positions: UP, HOLD and DOWN. The switch is inactive unless the PLC is in manual mode. In the UP position, the head will rise until it trips the head up limit which is adjustable via the PLC. In the HOLD position the head will stay still. In the DOWN position the head will descend until it reaches the bottom of the stroke. The speed of descent is controlled by the Head Feed and Head Force Limit controls.



**BLADE START** - The blade can be started only when the hydraulics are running in either manual or auto mode.

**NOTE:** In automatic Mode the head will not descend until the blade has been started, which the PLC will prompt the operator to do so.



**HYDRAULIC START** - To start the hydraulic system, the switches for the head and both vises must be in the "NEUTRAL" position. The "HYDRAULIC START" button must be depressed and held in momentarily until the PLC display becomes active.



**CYCLE START / PAUSE** - This button starts the cutting cycles and will stay illuminated white until the cycles are completed. The PLC control system will prompt you to start the blade if it is not running. The machine will then begin the automatic cycle until completed when it will shut itself off. The current cycle can be PAUSED by pressing this button at any time during a cycle and restarted by pressing it again.

### CENTER ROW



**COOLANT** - This switch has three positions, WASH, OFF, and ON. In the WASH position, the coolant system will operate when there is power to the machine, this allows using the wash gun to clean the machine. In the OFF position, the coolant system is inactive. In the ON position the coolant system will only run when the head is descending. This minimizes coolant carry over on the stock.



**SHUTTLE VISE** - This switch has three positions, OPEN, HOLD and CLOSE. With the switch held in the OPEN position the vise will open all the way or until the switch is released. With the switch in the HOLD position, the vise will stay where it is and will not move freely although it will not resist a large force indefinitely without creeping. In CLOSE, the vise will close all the way, or until it encounters enough resistance to stop it.



**BLADE SPEED** - This dial will increase or decrease the speed at any time while the blade is running.



**BLADE STOP BUTTON** - Stops the blade. If the blade is stopped during a cycle, the cycle will continue but will not let the head descend until the blade is started.

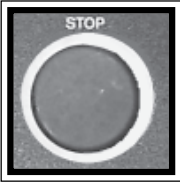

**STOP** - This mushroom button stops the blade and hydraulic motors. Both vises will hold their position but, pressure will begin to fall off. Long pieces of work should always be supported so they will not become loose over time and fall while the machine is shut down. This is a latched button and must be pulled out to start the machine.

### **BOTTOM ROW**



**WORK LAMP** - This option switch has two positions, OFF and ON.

### **OPTIONAL CONTROLS**



**AUXILLARY VISE** - This switch has three positions, OPEN, HOLD and CLOSE. With the switch held in the OPEN position the vise will open all the way or until the switch is released. With the switch in the HOLD position, the vise will stay where it is and will not move freely although it will not resist a large force indefinitely without creeping. In CLOSE, the vise will close all the way, or until it encounters enough resistance to stop it.



**LASER GUIDE** - This option switch has two positions, OFF and ON.

---

## **PLC 100 CONTROL SYSTEM**

**NOTE:** This instruction manual is applicable to the H-14 equipped with a MITSUBISHI PLC manufactured after and including the following serial numbers:



Machine Model	Serial #
H-18S	B1001099, B1001103

**E200 operator interface.**

### **OPERATION OVERVIEW**

The PLC is a programmable logic controller which allows the operator to run the machine in both manual and automatic modes.

In manual mode, all functions can be operated by using a combination of selector switches on the control console and the PLC function buttons. Also the operator has the ability to execute a single cut utilizing a preprogrammed "Single Part Cycle".

In automatic mode, the PLC has the capacity to program and store 99 jobs. Designated job numbers can be programmed for quantity required (maximum of 999 pieces) and lengths from 0" to 220" (5588mm).

Jobs can be run individually or in a QUEUE which allows a maximum of 5 jobs to run consecutively and the queue can be repeated automatically as well up to 99 times.

All machine operators should be familiar with the entire operation instructions prior to operating the machine.

**NOTE:** If an emergency situation arises during any operation, use the large red mushroom "STOP" button located on the control panel to shut down the machine. To operate the machine, the "STOP" button must be pulled out.

## ACTIVATING THE PLC

Position the head, fixed vise, and shuttle vise switches to the **NEUTRAL** (center) positions. If any of these switches are not in the **NEUTRAL** position, the hydraulics will not start. The PLC control will become active when the **HYDRAULIC START** button is depressed and "held in" momentarily. First, the HMI and PLC's current revision number will be shown on the display window and finally the **MANUAL MODE** display window will appear as shown below. The **AUTO/MAN** green indicator light will be on and all **MANUAL** controls are enabled. The "**LTH**" value (shuttle vise position) will always display zero at start up. The "**LTH**" value can be reset or cleared at any time in **MANUAL** mode by pressing the **CLEAR** function button.

## PLC CONTROL PANEL

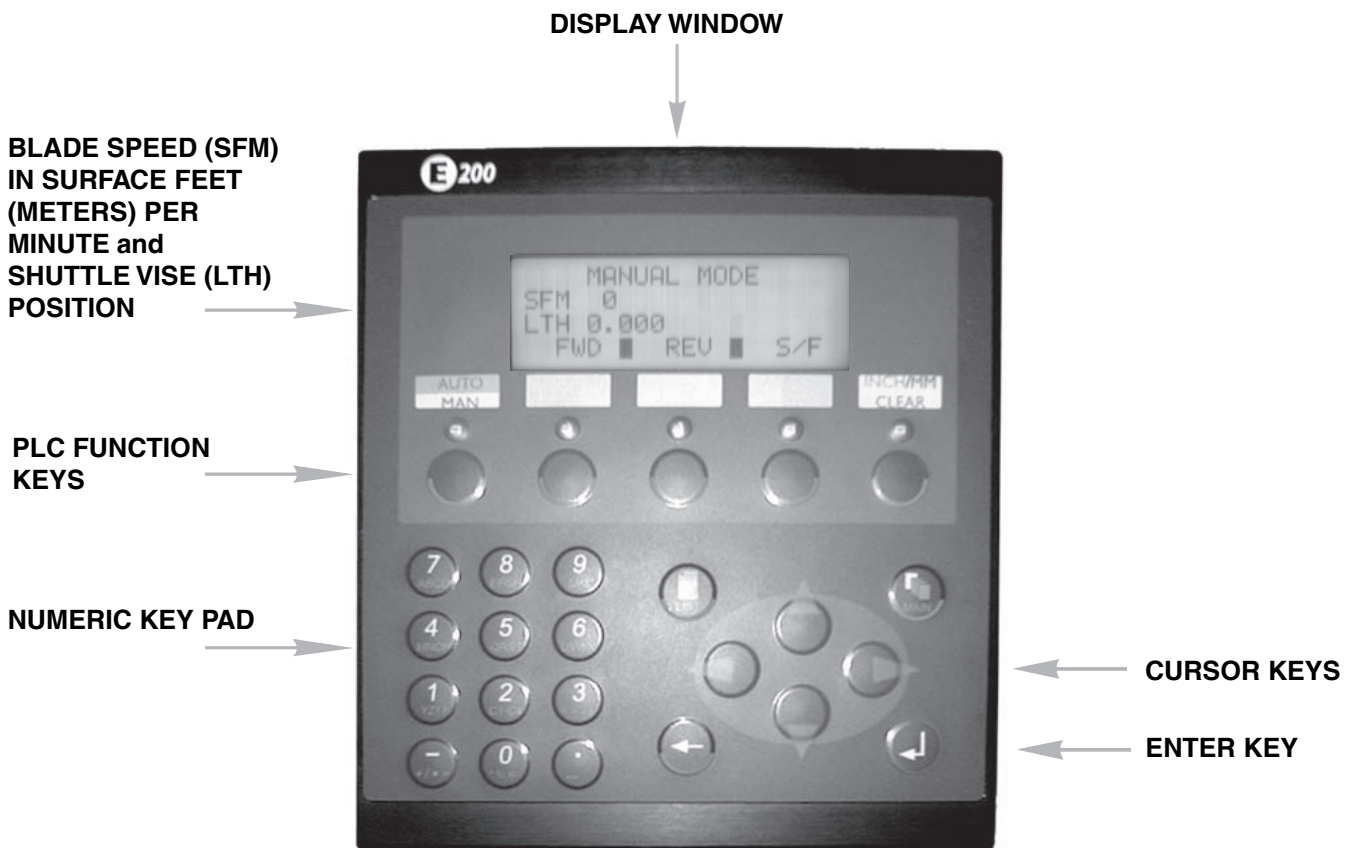

## FUNCTION KEY DESCRIPTIONS

If a red indicator light above a function button is illuminated, it means that the function printed in red at the top of the button is enabled. No light indicates the function printed in black at the bottom of the function button is enabled.

The following are the function keys for AUTO and MAN modes:



### AUTO / MAN MODE

- This key will toggle between MAN and AUTO modes. Auto mode cannot be accessed unless the front vise is closed.
- Also used to stop an automatic job in progress by switching to MANUAL mode.



### UNLABELLED

- The function of these keys are displayed directly above them. The function will change as the PLC is switched from one mode to another and as process of each mode is changed.



### INCH/MM / CLEAR

- While depressed momentarily, it resets the displayed length value to zero. If held depressed for a few seconds, the displayed length will toggle between millimeters and inches and the blade speed in either surface feet per minute or meters per minute. It becomes disabled once any cycle is initiated.

## MANUAL MODE FUNCTION KEY DESCRIPTIONS

While in manual mode, the display will show the current function of the unlabelled key. They are shown below.

**FWD : FORWARD** - This key will advance the shuttle vise toward the head (home position). If pressed simultaneously with the **REV** key, (the front vise must be closed and a password is required) the parameters will be displayed.

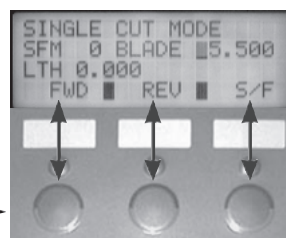



**S/F : SLOW / FAST** - This key will toggle between slow and fast shuttle speed.

**REV : REVERSE** - This key will retract the shuttle vise away from the head (home position). If pressed simultaneously with the **FWD** key, (the front vise must be closed and a password is required) the parameters will be displayed.

## SINGLE PART CYCLE OPERATION

In MAN mode, the PLC allows the operator to initiate a "Single Part Cycle " to cut one piece at a desired length. To accomplish this, follow the procedure below.

- 1) A trim cut should be made before initiating the "Single Part Cycle " operation.
- 2) Make sure the front vise switch is in the closed position and set the head up limit switch. The AUTO/MAN indicator light will flash alternately green and red.
- 3) Make sure the head is set so that the blade is above the material and the head selector switch is in the HOLD position.

4) The cursor will be flashing at the LENGTH position. Key in the desired value from 0" to 220" and press . If the value is incorrect, re-enter the value and press  again.

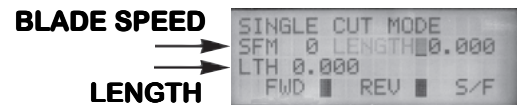

5) If the blade is not running, you will be prompted by the word "BLADE" flashing on the display window. Start the blade and adjust the blade speed as required.



6) When the blade is started, the word "BLADE" will change to the word "CYCLE" flashing on the display window. Press **CYCLE START** and the cycle will begin.



7) When the cycle button is pressed, the shuttle vise will move forward to the home position before executing the length movement. The head will descend and make the cut.

8) When the cut is completed, the head will rise to the head up limit switch, the blade will stop and the display window will reset for the next cut.

9) To cut another piece, repeat steps 2 through 6.

- NOTES:**
- 1) To "PAUSE" the "SINGLE CUT CYCLE", press the "CYCLE START" button. The "CYCLE START" button will begin to flash and the screen will indicate a paused condition. All movements will immediately cease. To continue the cycle, press "CYCLE START" button again.
  - 2) To cut multiple pieces, switch to AUTO MODE and follow the automatic procedures.

## KERF CORRECTION

When making cuts, the PLC must account for an amount called the "KERF" which is the material removed by the blade. This value must be entered into the PLC and must be checked and adjusted as required when the blade has been replaced. This is due to the fact that there is a variance in the kerf value from blade to blade. The original value entered is for the blade installed at the time of manufacture. If the kerf value is to be adjusted it's value can be accessed while in Auto Mode. Press and hold the  key below the word "KERF" on the display until the display appears as shown. Enter the desired kerf value and press .



Returns to Auto Mode.



Returns to the Queue.

**NOTE:** Whenever a new job or new material is being loaded for production, the head up limit switch should be properly set (ref pg 20) to clear the material, positioned for a trim cut and the front vise closed (in "MANUAL MODE").

## **AUTOMATIC OPERATION**

When the AUTO/MAN button is pressed, the red indicator light above it will come on, and the blade will stop if it has been running. The screen will change to the JOB display window as shown below and be ready for editing or starting a new job. All manual functions will be disabled.



## **PROCEDURE FOR EDITING OR STARTING A NEW JOB IN AUTO MODE**

1) In AUTO mode, key in a job number from 0 to 99 and press . The REQUIRED QUANTITY (RQ), LENGTH (LTH) and QUANTITY (CT) will be displayed. The values displayed can be edited by pressing ENTER after each new value, and the job will be stored in memory with the new values. To navigate through the values, use the CURSOR keys.

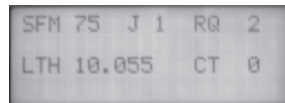

2) After the values are entered, press the **CYCLE START** button, the switch will illuminate, the display window will prompt you to start the blade for a trim cut (if the "Trim Cut" parameter has been selected).

**CAUTION;** If the head is in its down position, it will rise to the head up limit so that no damage to the blade will occur.



3) After starting the blade, the head will descend for the cut and the machine will complete the required job.

### **JOB IN PROGRESS**

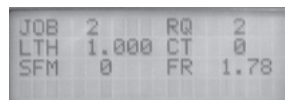

4) At the completion of the job, the machine will shut down if "0" has been entered in the "POWER DWN TIMER" parameter or continue running for the specified time up to a maximum of 180 minutes.

### **NOTES:**

1) The "CT" value is the accumulated total number of parts that have been cut from the JOB number since it was last reset. The machine will only cut the quantity which is the difference between REQUIRED QUANTITY and CUT QUANTITY. When REQUIRED QUANTITY equals CUT QUANTITY, the machine AUTO CYCLE will stop and you will be unable to restart the same job until the "CUT QUANTITY" value has been reset.

2) The AUTO cycle may be exited and stopped at any time by pressing the key.

**NOTE:** Before entering "AUTO MODE" and working with a "QUEUE", follow the same procedures outlined on the previous page for "AUTOMATIC OPERATION" with regards to setting up for an initial trim cut.

## WORKING WITH A QUEUE

The purpose of a QUEUE is to allow the operator to run several jobs (max of 5) in series if they are of the same material and shape.

In AUTO mode, press the  key below the word "QUE" on the display and the display window will appear as shown.

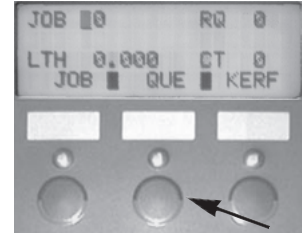

If you choose to VIEW the QUEUE, press the  key below the words "VIEW QUE" on the display. The display window will show the jobs in the current QUEUE. Four jobs at a time are shown.

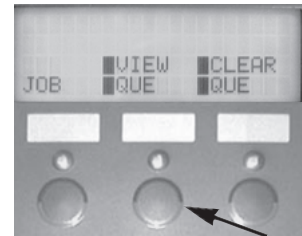
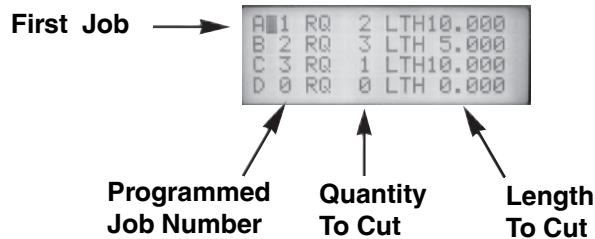

Use the CURSOR buttons to view all the jobs. To run the QUEUE as it is displayed (jobs may be edited in this mode), press the CYCLE START button on the control panel. The screen will now prompt you to start the blade for a trim cut.





If you choose to Edit the QUEUE, press the  key below the words "CLEAR QUE" on the display. This will clear any jobs that are in the QUEUE and the display window will show an empty Queue. Jobs may be entered and edited in this mode.

To fill the QUEUE, follow these two steps.

1) Key in a job number and press ENTER. If that job number has previously been programmed, it's values will be displayed. The cursor will move to the next position in the QUEUE. Up to five jobs may be in the QUEUE at any time. The job values can be edited in this mode.

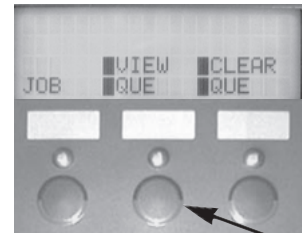
2) When the desired jobs have been entered, you may press the CYCLE START button on the control panel to execute the jobs in the QUEUE. (Follow the same procedures to initiate a cycle as in "AUTOMATIC OPERATION")



The QUEUE may be exited to the previous screen at any time by pressing the  key under JOB. At completion of the "QUEUE", the machine will shut down if "0" has been entered in the "POWER DWN TIMER" parameter or continue running for the specified time up to a maximum of 180 minutes.

## HYDRAULIC FEED CONTROL

The Hydraulic Feed Control is located to the left of the control panel. These controls allow independent control of Feed Force and Feed Rate.

**Fast Approach Lever**  
Depress for fast head descent.



**Feed Force Knob**  
Used to set Feed Force Limit (counterclockwise rotation to increase and clockwise rotation to decrease).

**Feed Rate Knob**  
Used to set Feed Rate (counterclockwise rotation to increase and clockwise rotation to decrease).

Hydraulic Feed Control

## CUTTING PARAMETERS CHART

A full size CUTTING PARAMETERS CHART is mounted on the front of the saw. The chart contains five steps for the operator to follow in order to achieve optimum performance of the saw. These steps are detailed on the following pages.

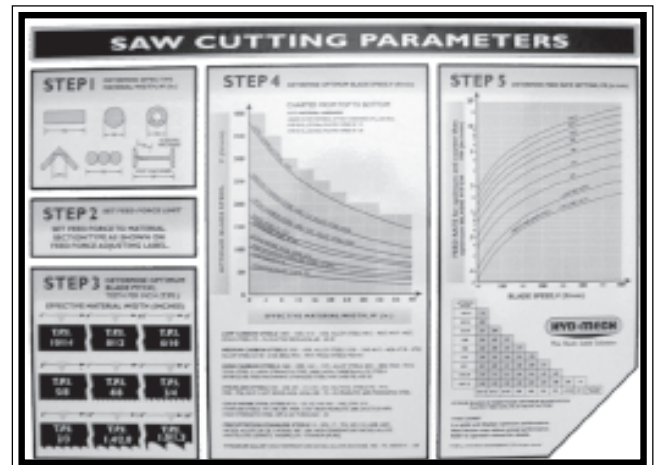

## CHART EXAMPLE #1

We will use the parameters chart to set up the saw for cutting 8" (200mm) Diameter #1045 Carbon Steel.

### STEP 1, DETERMINE EFFECTIVE MATERIAL WIDTH - W ( inches ) or (mm)

Effective material width, W (in.) for most common shapes of materials, is the widest solid part of the material to be in contact with blade during cutting. For simple shapes, as illustrated on the chart, this can be directly measured. For bundles of tubes and structurals, measuring the effective width is difficult. Effective width is 60% to 75% of the actual material width.

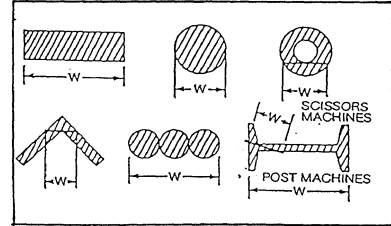

**Material Width Chart**

#### NOTES:

- 1) Both effective material width and guide arm width are used in setting the saw.
- 2) Guide arm width is the distance between the guide arms and is used in STEP 2.
- 3) Effective material width, as determined here in STEP 1, can be thought of as the average width of material "seen" by each tooth, and it is used in STEPS 3 and 4. In Example #1, for an 8" (200 mm) diameter solid, Effective Material Width is 8" (200mm).

### STEP 2, SET FEED FORCE LIMIT

The Feed Force Limit is the maximum amount of force with which the head is allowed to push the blade into the work-piece. FEED FORCE LIMIT should be set with the head in the down mode, according to the label.

#### CUTTING SOLIDS

For cutting solids, the wider the section, the less FF should be set, to avoid blade overloading. See the graph.

**EXAMPLE:** When cutting a solid which is 1/2 of machine capacity using the graph, locate 50% on the horizontal line and travel upwards to the plotted line and then travel directly across to the vertical FF Setting line. The point that you have arrived at shows a setting of 40% for a piece 50% of capacity.

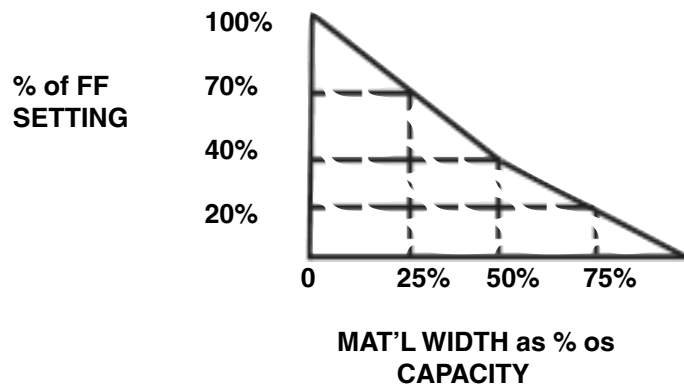

#### CUTTING STRUCTURALS

A reduced Feed Force Setting is used when cutting structurals:

For structurals, a blade finer than Optimum can be used for more efficient cutting.

If a finer than optimum blade is going to be used, Feed Force Setting should be reduced even further.

#### For OPTIMUM BLADE SELECTION, see STEP 3

BLADE	FF SETTING
① OPTIMUM PITCH FROM STEP 3	20%
② PITCH FINER THAN OPTIMUM	0%

### STEP 3, DETERMINE OPTIMUM BLADE PITCH - TEETH PER INCH (T.P.I.)

Selecting a blade with proper tooth pitch is important in order to achieve optimal cutting rates and good blade life.

For cutting narrow or thin wall structural materials a fine blade with many teeth per inch (T.P.I.) is recommended. For wide materials a blade with a coarse pitch should be used. The sketch can be referenced for the blade pitch changes for differing effective material widths.

It is impractical to change the blade to the proper pitch every time a different width of material is cut and it is not necessary, but remember that the optimum blade will cut most efficiently. Too fine a blade must be fed slower on wide material because the small gullets between the teeth will get packed with chips before they get across and out of the cut. Too coarse a blade must be fed slower because it has fewer teeth cutting and there is a limit to the depth of a cut taken by each tooth. Allowance for the use of a non-optimum blade is made in STEP 5.

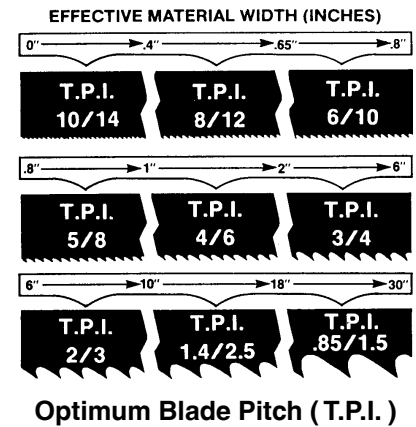

In our Example #1 : Effective material width of 8" (200 mm) & Optimum blade has 2/3 teeth per inch.

### STEP 4, DETERMINE OPTIMUM BLADE SPEED, V (ft/min) (m/min)

The relationship between optimum blade speed and effective material width for various materials is represented on the graph shown.

The graph shows that as effective material width gets wider or as material gets harder, lower blade speeds are recommended. If material is narrow or soft, higher blades speeds should be selected.

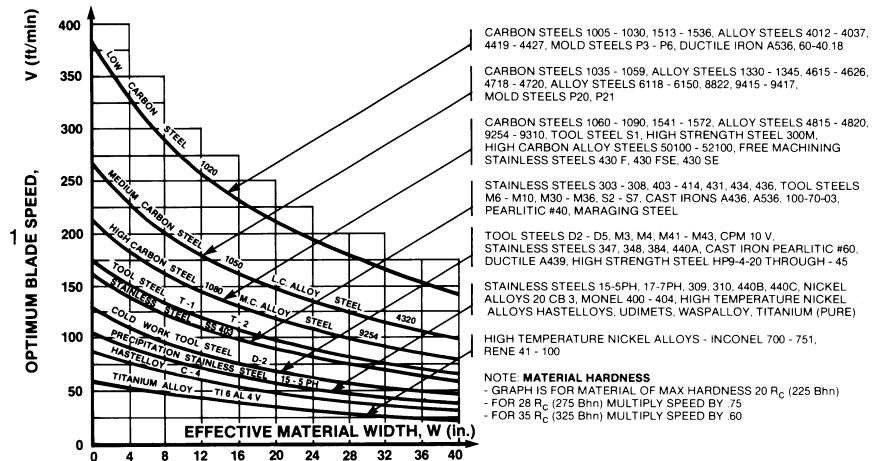

In Example #1

- 8" (200mm) diameter #1045 Medium Carbon Steel solid bar is to be cut.
- On the graph above find the Medium Carbon Steel Curve which represents the optimum blade speeds for 1045 Carbon Steel.
- On the horizontal axis (effective material width axis) find number 8 which represents effective material width of an 8" (200mm) diameter solid.
- Find the point where a vertical line from 8" (200mm) intersects the Medium Carbon Steel Curve.
- From this intersection point run horizontally left to the vertical axis (optimum blade speed axis) and find the point marked "200".

For 8" (200mm) diameter, 1045 Carbon Steel solid bar 200 ft/min (60m/min) is the optimum blade speed.

**NOTE:** 1) Higher than optimum blade speed will cause rapid blade dulling. Lower than optimum blade speeds reduce cutting rates proportionately and do not result in significantly longer blade life except where there is a vibration problem. If the blade vibrates appreciably at optimum speed as most often occurs with structurals and bundles, a lower blade speed may reduce vibration and prevent premature blade failure.

2) Material Hardness - The graph above illustrates blade speed curves for materials of hardness 20 RC (225 Bhn) or lower. If the material is hardened then the multipliers need to be used. These multipliers are given in the NOTE at the bottom right of the graph. As the hardness increases the optimum blade speed decreases.

The following table gives examples of the optimum blade speeds for different materials.

NO.	MATERIALS	OPTIMUM BLADE SPEED	
		ft/min	m/min
1	5" (125mm) Dia Solid Carbon Steel	225	70
2	12" (300mm) I-Beam	290	90
3	4" x 4" (100 x 100mm) Rec Tube, 1/4" (6mm) Wall	350	110
4	4"(100) 400 Stainless Steel	140	45
5	2" x 2" (50 x 50mm) Rec Tube 1/4" (6mm) Wall		
6	Bundle 5 x 5pcs 10" x 10" (500 x 500mm)	325	100
	3" x 3" (75 x 75mm) Inconel	60	20

Materials and Blade Speed

**STEP 5, DETERMINE FEED RATE SETTING, FR (in/min) (mm/min).**

**FEED RATE is the vertical speed at which the blade descends through the work-piece.**

The FEED RATE Knob controls FEED RATE of the blade descent in the range 0 to 15 in/min (380mm/min). The FEED RATE should be adjusted only in one direction (from "O" to required value). If you go too far, go back to "O" and come back up. To set FEED RATE for particular cutting situations use the Graph below, which represents the relationship between FEED RATE, blade speed and blade pitch.

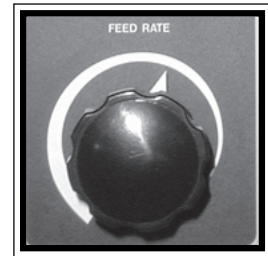

Feed Rate Knob

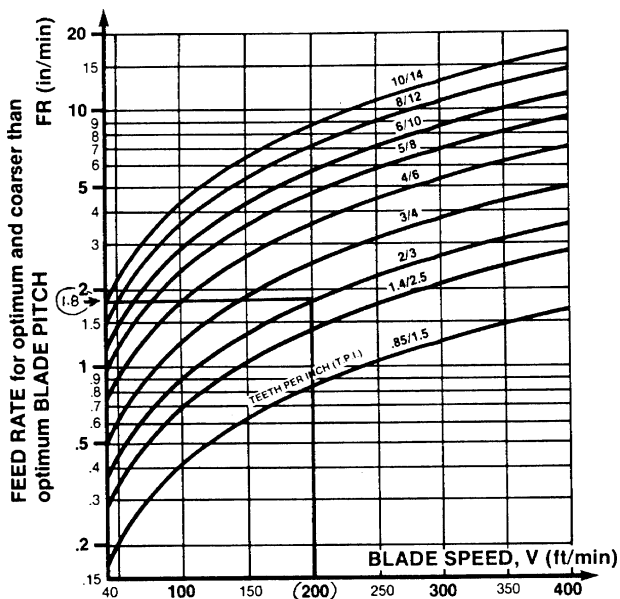

Feed Rate Calculation

**For Example #1**, it is known from Step 3 that optimum blade pitch is 2/3, and from Step 4 that blade speed, is 200 ft/min (60mm/min). From the Graph on the left, the FEED RATE is determined in the following way:

- On the horizontal axis (blade speed axis), find 200 ft/min (60mm/min).
- Find the point where a vertical line from 200 ft/min (60mm/min) would intersect the 2/3 blade pitch curve.
- From this intersection point run horizontally left to the vertical (FEED RATE) axis, to arrive at 1.8 in/min (45mm/min) FEED RATE. Thus 1.8 in/min (45mm/min) is the FEED RATE for cutting 8" (200mm) diameter 1045 Carbon Steel when the optimum 2/3 pitch blade is used.



## ADDITIONAL CONTROLS

### COOLANT FLOW

The main coolant control is found on the control panel.



**WASH:** Coolant flows any time the machine is under power, permitting wash down with spray nozzle without running machine.

**OFF:** No coolant flow.

**ON:** The coolant flows only when the blade is running **OR** when the blade is running and the head is descending. This is selectable via the PLC parameters.

The bandsaw is equipped with two independently controlled coolant spouts that are capable of supplying a generous flow of coolant to the blade.

The left guide arm supplies a flow of coolant that should flood the blade as it moves through the carbide pads into the material to be cut. The adjustable spout on the left guide arm should be set with the blade speed to provide the flood of coolant necessary.

The right guide arm provides a coolant flow through the flexible hose that can be pointed directly where necessary. This flexible hose should be used when cutting solid bars, bundles, or wide structurals. Set the flow of coolant directly into the opening in the material where the blade is cutting.

**NOTE:** When cutting materials that do not need constant coolant, such as Cast Iron, some coolant flow is required for blade lubrication to prevent blade scoring by the carbide pads as the blade moves through them.

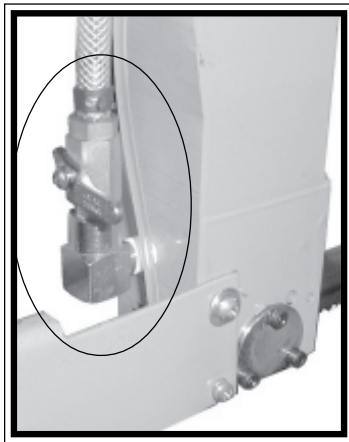

Guide arm coolant valve.

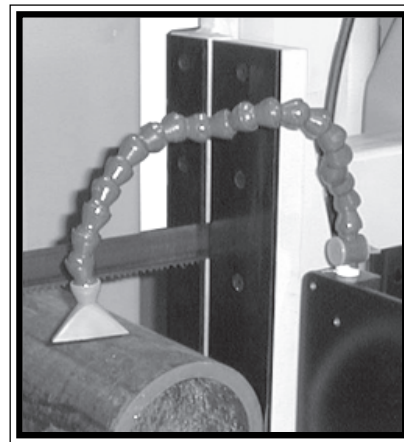

Flexible nozzle assembly.

### HEAD UP and DOWN LIMIT SETTING

The head up limit is used to restrict the distance the head travels for each stroke. It can be adjusted at any time by moving the switch trip plate to any position on the vertical bar. The trip plate & switches are found behind the head on the drive end near the gear box.

**Head Up Limit:** In order to maximize production in the automatic, cycle the Head Up Limit should be set to just clear the height of the material.

**Head Down Limit:** This limit is factory set and under ordinary cutting requirements should not be changed. If changed, it may cause the machine to malfunction in the automatic cycle.

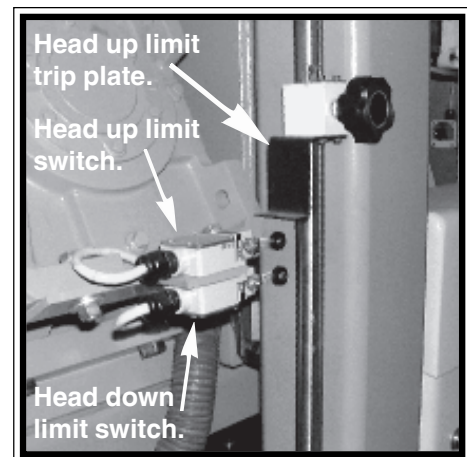

## ***BUNDLING OPERATION (OPTION)***

The bundling vises can be operated in direct conjunction with the front and shuttle vises or at a slower clamping speed. Either bundling can be turned on or off at any time. The on / off valves are shown in the photos.

The speed at which the bundling jaws close can be adjusted as required by turning the flow control valves (shown in the photos) for each bundling cylinder.

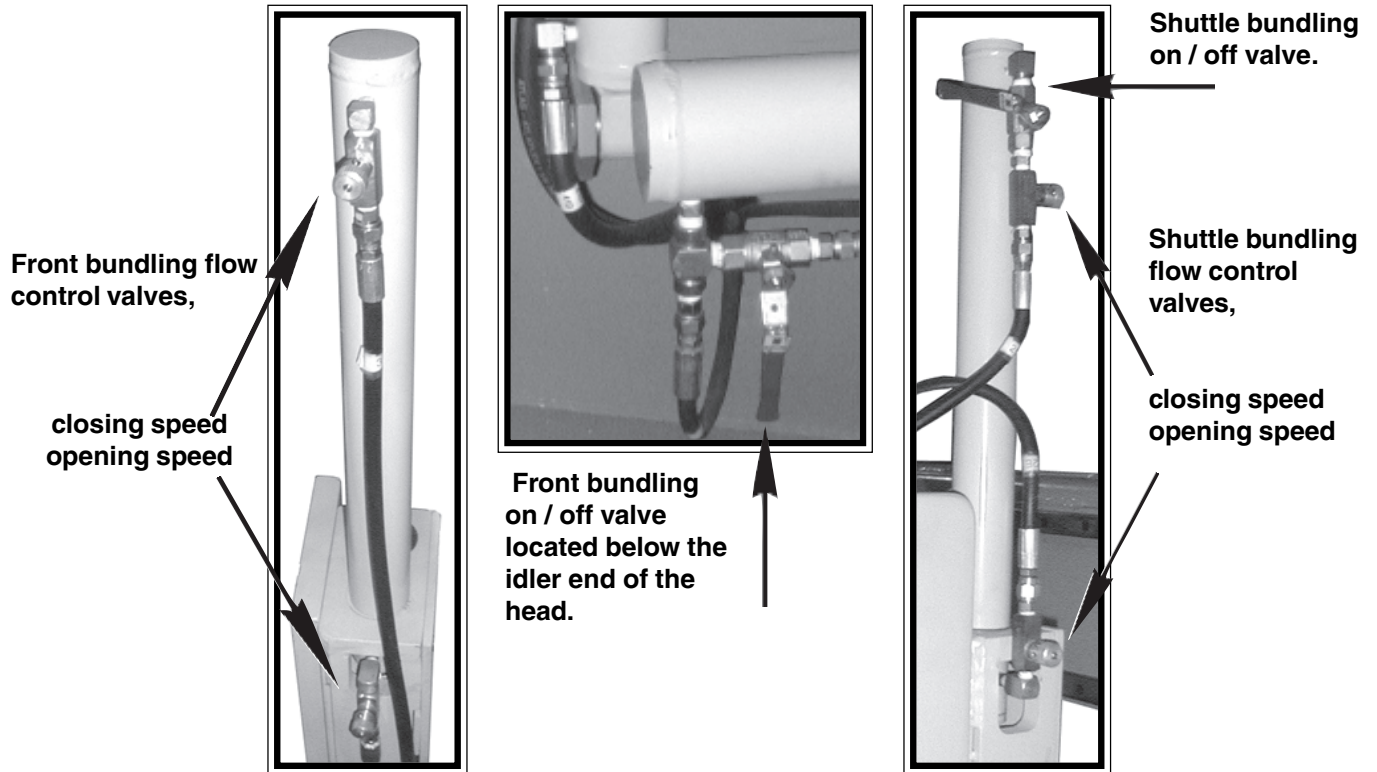

## ***VARIABLE VISE PRESSURE (OPTION)***

This options allows the operator to adjust the vise pressure. This can be valuable when cutting light structurals and tubes. By reducing the vise pressure from the system (H18=1000, H22=1100psi) pressure, distortion of materials is prevented. The controls are located at the drive end of the machine.



---

## **SECTION 3, MAINTENANCE AND TROUBLE SHOOTING**

### **LOCK -OUT**

**Purpose:** To prevent injury to workers caused by unexpected start-up of machines being worked on.  
**OR**  
Where the starting of a machine or device may endanger the safety of a worker

- a) Control switches or other control mechanisms shall be locked out;
- AND**
- b) Other effective precautions necessary to prevent such starting shall be taken

### **LOCK OUT PROCEDURE**

Whenever work is to be performed on a machine, the person in charge should follow Lockout procedures as is required by his organization. The main power disconnect box is supplied with a suitable mechanism for this purpose as shown below. To place a lock on the switch, turn the switch to OFF and pull the white tab out from the center of the switch.



**Switch shown in the OFF position.**

## **BLADE CHANGING PROCEDURE**

**NOTE:** *Wear gloves, safety glasses and a long sleeve shirt for protection from the sharp blade. The hydraulics should be OFF any time the operator has his/her hands in contact with the blade.*

- 1) Select MANUAL mode and raise the head so the drive door will clear the electrical control panel.
- 2) Release the blade tension by turning the Blade Tension Switch to "-".
- 3) Remove the blade guard.
- 4) Shut the machine off and open the idler and drive doors.
- 5) At the top of the head, the saw blade runs in a protective channel. Grip the blade at each end of this channel and twist the blade teeth down past the channel and slide the blade forward. Let the blade rest on the out feed table, then slide the blade down and out of the carbide guides.



**(2) Blade tensioning switch in the tension or run position.**

- 6) Before installing the new blade, check that it measures 1.615" wide including the teeth. Some blade manufacturers supply blades that measure 1.5" including the teeth. The same applies to 2" blades, they should measure 2.120". In this case you may not be able to adjust the head down limit to complete the cut.
- 7) Your new blade will be in a coil. While wearing gloves, hold the blade away from yourself, twist the blade to uncoil it. Do not let the blade teeth bounce on the concrete floor as some damage to the blade may be caused.
- 8) Place the new blade in the carbide guides and then slide the blade over the wheels. The teeth should be pointing towards the drive side as they pass through the carbide guides.
- 9) Turn the machine on and the blade tension switch to the "+ RUN" position, turn the two carbide locking handles clockwise to the locked position. Jog the blade a few rotations to check that the blade is not moving on or off the wheels.

**NOTE:** Whenever the blade is changed, the KERF value (1 1/4" blade = 0.060" - 0.065", 1 1/2" blade = 0.076 - 0.082") should be checked and the new value entered into the PLC. See page 12 for entering instructions.

## **BLADE BRUSH ADJUSTMENT**

The blade brush is properly set when machine leaves the factory, but it wears out during operation and needs to be readjusted periodically. The blade brush assembly is found behind the drive side door and is shown below. To adjust the assembly, loosen the hex nut, turn the set screw counterclockwise until the wires on the brush touch the bottom of the blade gullets and tighten the hex nut.

The brush should be replaced as it becomes worn to approximately 70% of it's original 3" diameter. Replacements can be purchased through your Hyd-Mech Dealer.

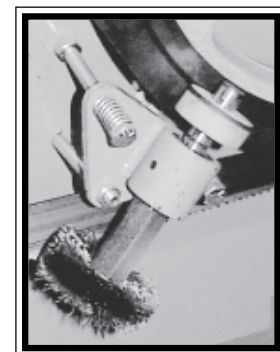

**H-18 blade brush.**

## ***BLADE TRACKING ADJUSTMENT***

For an H-18, blade tracking is set so the teeth of the blade protrude .260" (6.6mm), +/- .01 from the face of the wheels.

### ***IDLER WHEEL TRACKING***

Release blade tension before adjusting. The tracking is adjusted by regulating the "push" set screws and the "pull" hex bolts. Before making any adjustments, bolts "A & B" should be loosened but remain snug. This will allow easy movement for the slide assembly. It should be noted that most adjustments can be made with the "B & D" bolts. Loosening bolts "A" and turning in set screws "C" by equal amounts will move the blade off the wheel. Loosening bolts "B" and turning in set screws "D" by equal amounts will move the blade on to the wheel. After each "C" or "D" adjustment, tighten bolts "A & B", run the blade and then check the tracking.

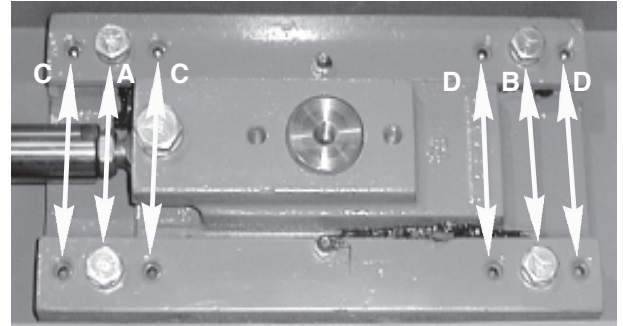

**Tracking adjusting bolts & set screws.**

### ***DRIVE WHEEL TRACKING***

Release blade tension before adjusting. Loosening bolts "A" and turning in set screws "C" by equal amounts will move the blade OFF the wheel. Loosening bolts "B" and turning in set screws "D" by equal amounts will move the blade ON to the wheel. After each "C" or "D" set screw adjustment, tighten bolts "A" or "B", turn tension switch to "+ RUN", run the blade for a moment and recheck the tracking.

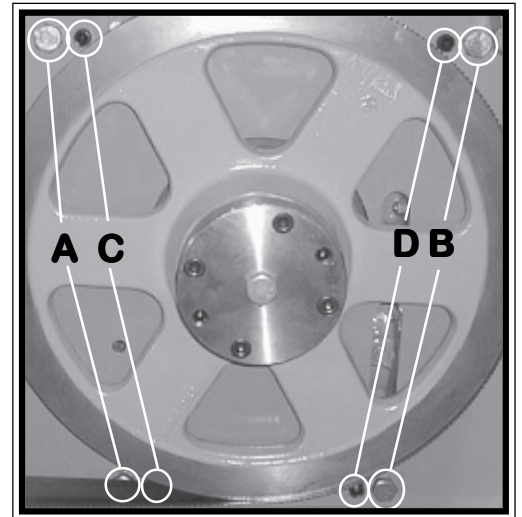

**Drive wheel tracking bolts & set screws.**

### ***CAM FOLLOWER ADJUSTMENT***

There are two cam followers mounted on the head frame. The set of cam followers is shown in the photo. One of them is fixed and the other is adjustable. The cam followers are factory set and usually do not require adjustment. In a properly adjusted system of cam followers only one side should be in contact with the guide. The gap between the other and the guide bar should not exceed 0.001". If it exceeds 0.001" you should contact your dealer to arrange for adjustment.

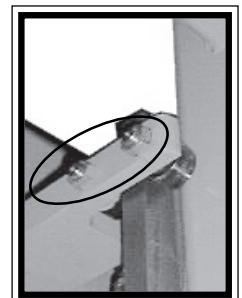

**Cam followers.**

## H-18 HYDRAULIC CARBIDE SET-UP PROCEDURE

- 1) Clean the roll pin bored holes and remove all burrs.
- 2) Install the roll pins with the gaps toward the top of the guide arms. Install the top carbide and check with a straightedge that the carbide can rock back and forth on the larger middle roll pin. Rock the carbide back until the straightedge touches one of the smaller roll pins, Measure with a feeler gauge between the straightedge and the other roll pin, this measurement should not be less than .020/inch.
- 3) Install the fixed carbide and check with a flashlight for any gap behind the pad. (It may be necessary to break the corner or rotate the pad for a proper fit).
- 4) Install a .015/inch shim and a .015/inch spring tension washer into the piston bore, followed by the piston and then the carbide pad. Install the cover and apply pressure, measure the gap and shim as needed to achieve .043/inch gap  $\pm$  .001/inch. After the pads are set, ensure that the carbide gap is uniform (see sketch below) check that the top carbide is still able to rock.

### Notes:

- 1) Make sure that the .750/inch O.D. of the spring washers and shims are slightly less than .750/inch to prevent any binding in the bore of the piston.
- 2) In certain situations it may be necessary, and is recommended to remove the threads on the front carbide pad, to allow it to float on the piston rather than thread onto the piston, this will allow for easier alignment and proper setup of the required gap.

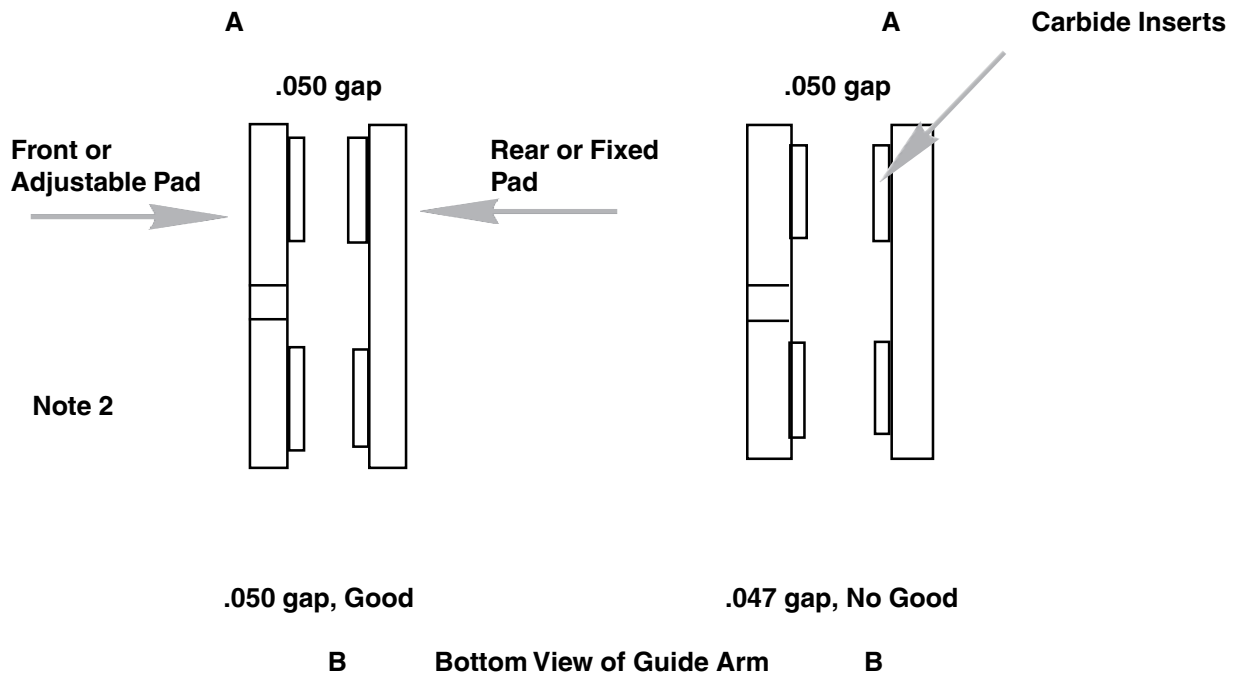

## LUBRICATION

The design of the H-18 was intended to minimize maintenance, although periodically certain moving parts need lubrication. We recommend that this periodic lubrication be done once a month using any general purpose grease. In addition to the grease points shown, vise jaw guides, infeed rollers and bundling assemblies require greasing.



**H-18 idler wheel tension slider (one at both ends).**



**2 vise grease nipples**

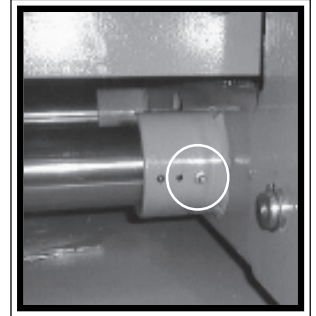

**2 shuttle shaft bearing housings (not on P models).**

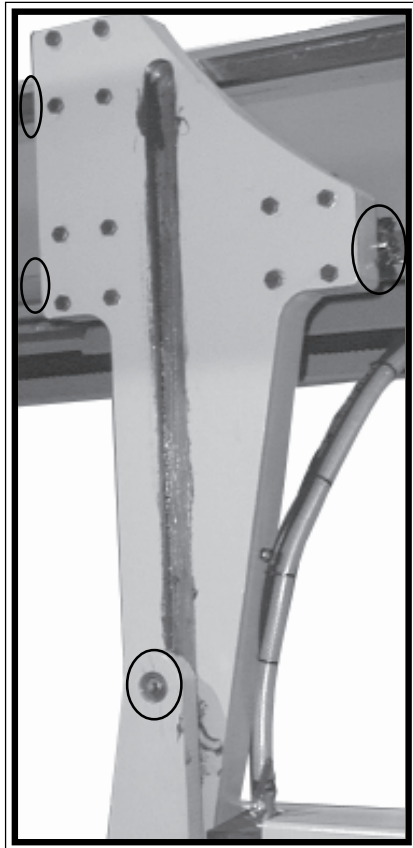

**Guide arm grease points (4).**

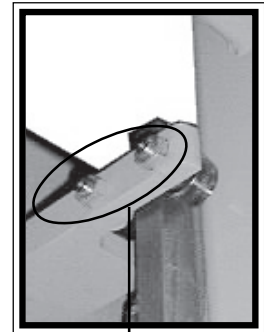

**Cam follower grease nipples.**



---

## **HYDRAULIC MAINTENANCE**

There are only FIVE items of routine maintenance associated with the hydraulic system.

1. OIL FILTER - Ten micron filtration of the hydraulic oil is provided by a spin on type filter mounted on the tank return line. The element should be changed after the first 50 Hours of operation and then every 500 working hours. Suitable replacement elements are:

CANFLO RSE-30-10  
GRESEN K-22001  
PARKER 921999  
ZINGA AE-10

2. OIL LEVEL - Oil level should be maintained in the upper half of the level gauge. Normally the rate of oil consumption will be very low and it should be unnecessary to add oil more often than at filter changes. Add oil only to the top line on level gauge.

The machine is shipped from the factory with ARCO Duro AW46 hydraulic oil. Generally any brand of recognized mineral hydraulic oil with the same properties should be compatible with Duro AW46, but to avoid any risk we suggest staying with Duro AW46. If it is desired to change brands, it is necessary to drain the tank and 1/3 refill it with the new oil, operate through several full strokes of each cylinder, drain the tank again, and finally fill the tank with the new brand.

Hydraulic tank capacity is approximately 11 US gallons (42 L).

Recommended replacement oils:

Chevron, AW Hydraulic Oil 46  
Esso, NUTO H46  
Mobil, Mobil DTE 25  
Texaco, Rando HD 46  
Shell, Tellus 46

3. OIL TEMPERATURE - Oil temperature is indicated by a thermometer contained in the level gauge. Oil temperature during steady operation should stabilize at about 50 - 55 F° (10-12°C) above room temperature. Thus in a 70 F° (20°C) shop one might expect an oil temperature of about 120 F° (50°C) Oil temperature should never exceed 160 F° (70°C)

4. OIL PRESSURE - Oil pressure is factory set to 950 PSI (6548 kPa ) for H-18 and should not require further attention except precautionary observation at start-up and every few days thereafter.

5. BLADE TENSION - Is preset at the factory and should under normal conditions not require attention. For adjustments, see the hydraulic schematic.

## **CLEANLINESS**

The heavy duty design should endure heavy operating conditions and provide the customer with flawless machine performance. To extend good performance some care is required especially as cleanliness is concerned.

The following areas should be kept clean:

- Control console free of dirt and grease.
- Door charts free of dirt and grease.
- Wheel boxes free of chips.
- Blade guides free of chips.
- Outfeed table free of chips.
- A large chip build-up should be avoided in the base of the saw.

**NOTE:** All parts must be cleaned before any repair service can be performed on them.

---

## **TROUBLE SHOOTING**

Most problems which may occur have relatively simple solutions which appear in this section. If the solution is not found here, contact the Hyd-Mech Distributor from whom you purchased your bandsaw. They have trained field service personnel who will be able to rectify the problem.

<b>PROBLEM</b>	<b>PROBABLE CAUSE</b>	<b>SOLUTION</b>
1. Saw is cutting out of square vertically.	1a. Blade worn.	1a. Replace blade.
	1b. Low blade tension.	1b. Reset blade tension.
	1c. Blade guides.	1c. Check for worn guides.
	1d. Excessive feed rate.	1d. Check for proper cutting parameters.
2. Saw is cutting out of square horizontally.	2. Stock not square in vises.	2. Adjust accordingly.
3. Blade comes off wheels.	3a. Not enough blade tension.	3a. Reset blade tension.
	3b. Improper tracking.	3b. Set tracking.
4. Blade stalls in cut.	4a. Not enough blade tension.	4a. Tension blade.
	4b. Excessive feed force.	4b. Reduce.
	4c. Excessive feed rate.	4c. Reduce.
	5a. Blade speed too fast.	5a. Reduce.
5. Blade vibrates excessively.	5b. Guide arms too far apart.	5b. Adjust accordingly.
	5c. Not enough blade tension.	5c. Reset blade tension.
	6a. Excessive blade tension.	6a. Reduce blade tension.
6. Excessive blade breakage.	6b. Excessive feed rate.	6b. Reduce.
	7a. Blade pitch too fine.	7a. Select coarser pitch.
7. Tooth strippage.	7b. Blade brush not cleaning.	7b. Adjust or replace blade brush.
	7c. Excessive feed rate.	7c. Reduce.
	7d. Excessive feed force.	7d. Reduce.
	8a. No coolant.	8a. Add coolant.
8. No coolant flow.	8b. Coolant line blocked.	8b. Blow out coolant line.
	8c. Coolant pump inoperable.	8c. Check, replace if

PROBLEM	PROBABLE CAUSE	SOLUTION
9. Saw will not start.	9a. Motor overload has tripped.  9b. Control circuit fuse has blown.  9c. Vise or head selector switch not in the center (neutral) position.	9a. Depress each of the overload buttons located in the electrical box. Depressing one button at a time and trying to start the saw will indicate which motor was overloaded.  9b. Replace the fuse in the control panel. Random blowouts may occur but a quickly repeated blowout points to an internal wiring fault.  9c. Turn all switches to the center (neutral) position.
10. Saw starts but will not run after Start button has been released.	10. On machines so equipped, the out-of-stock or blade breakage limit switch has been tripped.	10. Reload with stock or reset the blade. Hold the hydraulic start button and release the blade tension or open vises far enough to deactivate the limit switch.
11. Saw starts but no hydraulic functions.	11a. If blade wheels run clockwise, wrong phase order in power connection to saw.  11b. If pump is noisy cause may be low hydraulic oil level.  11c. Pump-motor coupling has separated.	11a. Stop immediately; reverse any two of the three phase connections.  11b. Stop immediately, add hydraulic oil. (See page 28 hydraulic maintenance.)  11c. Adjust accordingly.
<b>In Manual Mode</b>		
12. No individual function will respond to its manual control switch.	12a. Observe pilot light(s) on relevant valve. If pilot light fails to go on, problem is electrical.  12b. If pilot light related to inoperative function does light, problem may still be the coil . If problem remains it may result from dirt in the valve spool.	12a. This requires the attention of a qualified service person.  12b. Disassembly of hydraulic valves should be under taken only by qualified service personnel or those knowledgeable with hydraulic components.
13. Head will not descend.	13a. Feed Rate Valve is fully closed - pointer is set on "0" or close to "0" in/min.  13b. Feed Force Limit is set too low.  13d. Check for physical interference preventing the head from falling.	13a. Turn Feed Rate Knob in a counter clockwise to open valve.  13b. Increase Feed Force Limit.  13d. Remove obstructions.
<b>In Automatic Mode</b>		
14. Auto cycle will not start.	14. No job queue programmed to run.	14. Enter job numbers(s) and job data as described in Section 2.

---

## **PROGRAMMABLE LOGIC CONTROL, MITSUBISHI 100**

(with 2100 series software)

**NOTE:** The PLC is equipped with a lithium battery to keep the program stored while the power is shut down. The battery will need to be replaced every 3 to 5 years, depending on usage. A visual warning will be displayed on the interface when the battery drains to a certain level. Batteries can be purchased through your Hyd-Mech Distributor.

The programmable length control (PLC) uses signals from limit switches, control panel switches, an encoder (rotary shaft or linear) and information which is programmed into it, to supply accurate automatic length control and sawing functions.

The inputs used include;

- a head up limit switch, a head down limit switch.
- the machine function switches & push-button.
- proximity switch & encoders.
- also a signal from the auto/manual push button (telling the PLC whether auto or manual operation has been chosen).

An encoder is attached to the shuttle assembly and travels with the shuttle to provide length information to the PLC. A feed rate encoder is attached to the back of the head frame to provide feed rate information. And a proximity switch and target, mounted to the gearbox drive pulley or behind idler wheel, provides blade speed input to the PLC.

The programmed information includes PLC logic put into the PLC by its manufacturer, as well as information programmed in, through the keypad, by the assembly plant. Information from the assembly plant is referred to as the parameters. The parameters are important for the PLC to provide accurate sawing lengths and blade speed display. Following is a description of each parameter and the procedure to access them.

To access the PLC parameters:

In manual mode, with front vise switch in 'CLOSE' position press FWD. and REV buttons simultaneously ( not more than 0.5 sec. apart). The PLC will prompt for a password which is obtainable from Hyd-Mech. If the password is correct a screen of parameters will appear. The display will show four lines of parameters at a time. To move through the parameters use the cursor keys to scroll up or down. To change a parameter, cursor to that parameter line, and, using the number keys, type in the new value and press enter. To leave the parameters press the Auto/ Man key. The following page lists the available parameters and their definition.

---

## PLC 100 PARAMETERS

<i>Parameter</i>	<i>DEFINITION</i>
<b>SPEED CONST</b>	<b>Blade speed adjustment number.</b> If Actual Blade speed is different than displayed Blade Speed a new speed factor will need to be calculated. (Providing wheel Trgs is set correctly): Actual speed / Display = Adjustment factor X Existing speed factor = New speed factor.
<b>WHEEL TRGETS</b>	<b>Number of targets per revolution of the idler wheel.</b> S20A, S23A, H10/14, M16/20 = 1 H18/22, H28/32 = 6.
<b>HGT CLB (PRESS "ENTER")</b>	This is to be used only if calibration is required. Call Hyd-Mech Service department for instruction.
<b>ACTUAL HGT</b>	<b>Actual Height Value.</b> Value entered after performing length calibration procedure (described later in this section). This value represents the headfull stroke height.
<b>HGT CONST</b>	<b>Height constant.</b> Specifies linear distance of head movement in inches per one pulse of head encoder.
<b>LTH CLB (PRESS "ENTER")</b>	<b>Length calibration.</b> This is to be used only if calibration is required. Call Hyd-Mech Service department for instruction.
<b>ACTUAL LTH</b>	<b>Actual Length Value.</b> Value entered after performing length calibration procedure (described later in this section). PLC uses this value to calculate it's length encoder resolution and stroke parameter. <b>Note:</b> If Calibration Procedure is activated and not completed, or activated and a value not entered for ACT LTH, this value will reset to 00.000 and the PLC will not be able to count/display lengths.
<b>LTH CONST</b>	<b>Length constant.</b> Specifies linear distance of shuttle movement in inches per one pulse of shuttle encoder.
<b>ACCEL DIST</b>	<b>Shuttle acceleration distance.</b> Distance, in inches, the shuttle will travel slowly before reaching fast speed while starting to move in either direction. (i.e. 1.000).
<b>DECEL DIST</b>	<b>Shuttle deceleration distance.</b> Distance, in inches, the shuttle will travel slowly reaching home or target position. (i.e. 1.000)
<b>MIN FST DIST</b>	<b>Minimum fast speed distance.</b> If programmed length is smaller than this parameter override to slow speed. (Shuttle)
<b>TARGET WINDOW</b>	<b>Allowable +/- tolerance</b> from programmed length.
<b>FVO DWELL</b>	<b>Delay time</b> for the opening of the fixed VISE in seconds.
<b>SVO DWELL</b>	<b>Delay time</b> for the opening of the shuttle VISE in seconds.
<b>CLOSE TIME</b>	<b>Delay time</b> for the closing of the shuttle or fixed VISE in seconds.
<b>FEED RATE</b>	<b>Activates feed rate display.</b> Not active on S20A, S23A and H10 machines.
<b>ACTUAL POSITION</b>	If this value is set to "YES" displays shuttle vise actual position.
<b>HOLD SHT HOME</b>	<b>Hold shuttle VISE</b> home and closed during cut.
<b>BRKN PROX</b>	<b>Allows user to override signal</b> from prox switch in case it is broken. (When set to "NO" machine will not run with broken proximity sensor. Set to "YES" allows machine to run).
<b>MIN BLD SPEED</b>	<b>Minimum blade speed</b> on which the PLC will detect the that blade is running
<b>SPD PROX DELAY</b>	<b>Speed proximity delay</b> time between pulses read by the proximity switch on which the blade breakage function will be activated.

---- Continued ----

---

<b>POWER DWN TIMER</b>	<b>If “0” selected</b> , then the machine will shut down after the job is completed. This will allow the machine to continue running for a specified time after the job (in Manual Mode) or the cycle (in Auto Mode) has been completed. Range from “0” to “180” minutes.
<b>BLADE CLEAR</b>	<b>If set to “YES”</b> ; When the AUTO cycle reaches the function of head up, the shuttle will retract the material from the blade by 1/8" before the head will move up. When the head reaches the up position the next length of material is shuttled into position.
<b>TRIM CUT</b>	<b>If “YES” selected</b> the machine will perform a facing cut of the material at the beginning of an automatic cycle.
<b>OUT OF STOCK</b>	<b>Selecting “YES”</b> activates the out of stock option which prevents the shuttle vise from closing if insufficient length of material is available for the next length advance. Also stops the automatic cycle after completing the last cut.
<b>COOLANT</b>	<b>When “BLD” selected</b> , coolant flows when the blade is running. <b>When “BLD+ DWN” selected</b> , coolant flows when the blade is running and head is moving down.
<b>QUEUE</b>	<b>The queue allows</b> the operator to run several jobs (max 5) in series. <b>If “REPEAT”</b> is selected the above series will be executed the selected number of times.

---

## PLC 100 TROUBLESHOOTING

**PROBLEM #1,** *for automatic models with a shuttle.*

**PLC is not measuring lengths.**

### POSSIBLE CAUSES;

- i) Encoder
  - pinion gear loose on encoder shaft
  - bad encoder
- ii) Encoder Cable
  - bad connection at encoder or PLC
  - open or shorted wire
- ii) PLC unit
  - damaged hardware
- iii) Display unit
  - no power from PLC unit
  - damaged hardware
- iv) Actual Length (Actual LTH)
  - perform self calibration procedure and enter value.Parameter value is set to 00.000

### DIAGNOSIS;

**I)** With the machine in MANUAL mode; bring the shuttle forward to the home position and clear the length display to read '0.000'. Run the shuttle, in slow speed, to the rear then back to home, moving full shuttle strokes.

- length should accumulate on the display as a positive number when the shuttle move away from the blade and should count is negative going back and goes in a positive direction coming toward home, then the green channel wire and the white channel wire should be reversed.

- if the display alters between 0.000 and 0.001 or 0.000 and -0.001, then one of the encoder channels is not being recorded correctly.

**ii)** To determine the cause, first, check the encoder cable connections at both ends to be sure all four wires are connected properly. (See page 3.16 for connection / wiring information)

Measure the voltage:

- a)** At encoder connector; - between 0 V pin and 24 V pin. This voltage should be a minimum of 22 to 26 VDC.

If the voltage is incorrect; check encoder cable continuity - if OK, possible PLC problem.

If the voltage is correct, go to step b)

- b)** At encoder connector; - between 0 V and channel A and 0V and channel B. This should be slightly less than supply voltage at each channel.

If voltage is incorrect at this point, check for proper continuity of these wires and repair as necessary.

**NOTE:** When checking the encoder cable for continuity, each wire should also be checked for shorting to ground and shorting to each other. If voltage to the encoder is correct; go to Step C).

- c)** At the encoder connection of the PLC; - between 0 V and A&B channels.

With the shuttle moving slow, voltage should be approximately 10 -13 VDC. Input LED's X0 and X1 should flicker or go dim with the shuttle moving. If these LED's show no change with the shuttle moving, the encoder is likely at fault. Check that the pinion gear is securely fastened to the encoder shaft and that it can rotate along the rack as the shuttle moves.

If all mechanical components are functioning correctly then the encoder is defective.

If all tests check positive, the problem is in the PLC unit.

---- Continued ----

**PROBLEM # 2, for automatic models with a shuttle.**

**Inaccurate lengths in AUTO mode.**

**POSSIBLE CAUSES;**

- i) Encoder - pinion not engaging rack all the way from front to back; mechanical interference, pinion loose on encoder shaft.
- ii) Encoder Cable - bad connection at encoder or at PLC  
- intermittent open in one or more signal wires
- iii) Improper programmed information  
- existing parameter(s) incorrect  
- incorrect blade kerf
- iv) PLC - faulty PLC unit (not repairable in the field)

**GENERAL RULES** - Normally, three types of length inaccuracies may occur.

- 1) Inconsistent - lengths cut are not consistent, error changes. It doesn't matter how long the part required is the error is never the same.  
Cause: - most likely a defective electrical, hydraulic or mechanical component.
- 2) Consistent - lengths cut are consistent and the error is also consistent. The error always stays the same regardless of part length.  
Cause: - Kerf value
- 3) Linear - lengths cut are consistent but the error increases as the part length increases. The longer the part the greater the error.  
Cause: - when self-calibration is executed, incorrect "Act Lth" value entered

**DIAGNOSIS;**

- i) Check and record existing parameters. Also check for proper blade kerf.  
By making a cut part way into a piece of material and measuring the width of the cut, the operator can check blade kerf.

**INCONSISTENT INACCURACY**

- i) - With the machine in MANUAL mode, move the shuttle all the way forward and clear (zero) the length display. Move the shuttle in reverse, in slow speed, all the way to the end of it's travel. Return the shuttle forward to the home position, also in slow. The display should read 0.000" +/- .005". Do this test several times to be sure the read-out is repeatable.

**DIAGNOSIS;**

- i) Following the same procedure, run the shuttle alternating between fast and slow speed going back and coming forward. Again the display should be able to read 0.000" +/- .005" when returning to the home position. If the display does not read as specified:
  - check the encoder pinion gear to be sure it can run smoothly down the rack and that the gear and rack teeth engage over the entire travel of the shuttle.
  - check that the pinion gear is tight on the encoder shaft.
  - check the encoder cable connections, a loose connection could easily cause this concern.
  - remove the encoder from the machine and check that the shaft can rotate freely. There should be no binding or rough spots felt when spinning the shaft. Plug the encoder cable into the encoder, clear the length display, and rotate the shaft exactly (or as close as possible) one revolution. The display should read approximately 3.142" (positive or negative). Repeat this 3 or 4 times, spinning the shaft several times between tries.

---- Continued ----

---

## **CONSISTENT INACCURACY**

(make sure blade kerf value is correct)

- change "Actual Pos." parameter to 1. This will make the PLC show actual shuttle travel in AUTO

With no material in the machine:

- program JOB 1 for 2 pieces of 5" length, JOB 2 for 2 pieces of 10" length, and JOB 3 for 2 pieces of a length as one shuttle will allow.
- enter JOBS 1, 2 and 3 into QUEUE.
- record measurement on the display each time the shuttle vise reaches the target length and closes. It should equal the required length plus the programmed kerf value. Check that this measurement is +/- .002" for each length. If the overshoot /undershoot is very inconsistent, it could be related to an incorrect shuttle cushion period. This may be caused by "Decel. Dist." parameter being set too low, defective fast or reverse output relays on the PLC, or the hydraulic cushion valve (located at the hydraulic manifold) may be faulty.

## **LINEAR INACCURACY**

(not valid for machines with linear encoder)

- i) - load machine with a piece of stock for test cutting
- open parameters screen
- initiate length calibration (see 41)
- re-enter new ACT LTH (Actual Length) value
- recut test lengths and check if accuracy is satisfactory.

**NOTE;** Linear inaccuracy may be corrected in two ways, by using the length calibration as described i) or by adjusting the LTH CONST as follows;

- load machine with a piece of stock for test cutting
- program the PLC to cut two pieces each of 1", 12" and a length equal to a shuttle and a half of the machine being checked.
- make the cuts and measure as accurately as possible (vernier caliper)
- using the formula provided below, calculate the new parameter "LTH CONST"

Formula for determining new parameter "LTH CONST"

Measured length divided by Programmed length X Existing constant = New "LTH CONST"

i.e. Programmed length	= 1.00"	Measured length	= .999"	-0.001" short
	= 12.00"		= 11.988"	-0.012" short
	= 60.00"		= 59.940"	-0.060" short

Existing parameter "LTH CONST" = 0.001256

11.988 divided by 12.00 x 0.001256 = 0.001255

The new parameter "LTH CONST" would be 0.001255. This value should be entered as the new "LTH CONST" parameter and test cuts repeated. Adjust the parameter again if necessary.

**GENERAL RULE:** Lowering the parameter value = longer shuttle travel = longer parts  
Increasing the value = shorter shuttle travel = shorter parts

---- Continued ----

---

**PROBLEM # 3, *for P models, disregard all references to a shuttle.***

***AUTO cycle not being completed***

In the AUTO mode, the PLC controls saw functions through output relays. For a certain function to be actuated, the PLC must first see specific input(s). Like the output relays, the input relays are located on the PLC unit. Directly beside input and output terminals are red LED lights, which light up when the corresponding input is being received or output is being actuated. Observation of these input/output LEDs can help to diagnose AUTO cycle problems. (See PLC UNIT drawing on page 39) When a problem occurs in the AUTO mode, the lights should be checked to see if they are coming on at the proper time or at all.

INPUT LED's           - If a specific input light does not come on when expected;  
                              - check for a faulty/misadjusted limit switch, push button, encoder or by faulty wiring and connections.  
                              - wiring for each limit switch should be connected from the VDC terminal connection to particular limit switch, and from the limit switch to the input connector of the PLC.

**NOTE:** All inputs are denoted by "X"  
          All outputs are denoted by "Y"

Following is information on output diagnosis and the sequence of inputs and outputs during AUTO cycle.

**AUTO CYCLE SEQUENCE:** After the mode push button is in the AUTO position and the job has been Programmed into the PLC, and the Cycle Start push button pressed:

- 1) Hydraulics running, the head should move to it's up limit, if it is not already there. Shuttle vise should open and come forward to the home position. HUP input light must come on for cycle to continue.  
**HUP input on** - cycle should continue, if not check outputs per step 2.  
**HUP input not on** - check that head up limit switch is being actuated, check limit switch / limit switch wiring.
- 2) Front vise should be closed, the shuttle vise should stay open and move back to the programmed length; FVC output should be on SVO output will light momentarily, REV output and FST output should be on when the shuttle moves back fast.
- 3) As the shuttle approaches target length the FST output should shut off and the shuttle should travel slow for the "Dec. Dist." parameter, cushion distance. (i.e. 1.00") When the shuttle reaches target length, the SVC output should light, and the shuttle vise should close on the material.
- 4) FVO output light should come monetarily on and front vise should open.
- 5) FWD output should light as will as FST for the shuttle to move forward in fast speed. FST will turn off when the shuttle home cushion period is reached and the shuttle should slow down into the home position.
- 6) FVC output should light and the front vise should close. FWD light should go out, HDN output should come on and the head should start to descend for the cut. If blade is not running at this time, auto cycle will hold until min. SFM is reached. Depending on "Hld Shtl Hm" parameter in the PLC, the shuttle may stay home and closed during the cut or may move back to pick up the next length. HUP input should go out as the head descends, and HUP L/S deactivates.
- 7) After the cut is completed HDN input should light, HDN output should go out, the HUP output should light and the head should move up. When the head reaches it's up limit, HUP input should come on, RHD output off and the cycle repeats with the next length being clamped on by the shuttle, front vise opening and the length being brought forward to home position.

As mentioned, beside each input and output terminal there is a bank of red LEDs. Each light corresponds to its input or output. An input LED will light when it's specific input signal is being received at the PLC and output LED's will light when the PLC commands specific outputs. If an output LED is on but the output does not happen, check for voltage at the specific output wire. If voltage is not present then either the output relay is faulty/stuck or the output (3 amp) fuse has blown (See fuse information on the next page). If a fuse is blown, a shorted directional valve coil (good coil should measure 30 to 40 ohms), shorted noise suppresser at the coil, or shorted wiring could be the cause. If the fuse is good and no output voltage condition still exists, with the output light on, then the relay is defective. If this is the case the PLC will have to be returned to the manufacturer for repair. (Contact Hyd-Mech Service).

---- Continued ----

---

## **FUSES**

The PLC has five glass fuses in line with it.

Fuse '4FU' is a 2 amp instant blow fuse which feeds power to the input side of the PLC through input terminal 'L'.

Fuses '5FU1' to '5FU4' are 3 amp time delay fuses which each supply power to a specific bank of output relays through that bank of relay's 'COM' terminal:

5FU1 is wired to terminal 'COM 1' supplying Outputs	- Y0, Y1, Y2, Y3
5FU3 to terminal 'COM 3' supplying Outputs	- Y10, Y11, Y12, Y13
5FU4 to terminal 'COM 4' supplying Outputs	- Y14, Y15, Y16, Y17
5FU5 +- terminall "COM 5" supplying outputs	-Y20, Y21, Y22, Y23

### **PROBLEM # 4**

#### ***No Display***

##### **POSSIBLE CAUSES;**

- i) No power to the PLC.
- ii) PLC unit failure.
- iii) Faulty connection of cable between PLC & Interface

##### **DIAGNOSIS;**

- i) Check POWER LED (see next page - Status lights) - to be on when the PLC is switched on. If the light is on, PLC may have failed. Check for proper connection of cable at PLC & at interface. If connection is secure replace. If light is not on - check the (2 amp) PLC fuse. If the fuse is OK, check power to it.

### **PROBLEM # 5**

#### ***No Blade Speed Display.***

##### **POSSIBLE CAUSES;**

- i) Fault at proximity sensor
  - bad sensor, misadjusted sensor (gap should be approx. 0.015")
  - contamination on the end of the sensor
- ii) Fault at the PLC
  - bad connection of sensor wiring
  - faulty PLC input

##### **DIAGNOSIS;**

- i) Check for LED light on the sensor - light on indicates prox. sensor power connections are correct and sensor is activated. Problem could be with the sensor, signal wire to the PLC or with the PLC. With blade running, proximity LED should pulse. Likewise, the PLC input LED (X2) should be pulsing. If both LED's are pulsing with the blade running, the PLC is the problem. If the sensor LED is pulsing but the input (X2) LED is not; there is a problem between the sensor and the PLC input (X2) terminal.
  - If the LED on the sensor is not on, the problem is with the sensor wiring or the sensor is at fault.

## MITSUBISHI 100 INPUTS & OUTPUTS

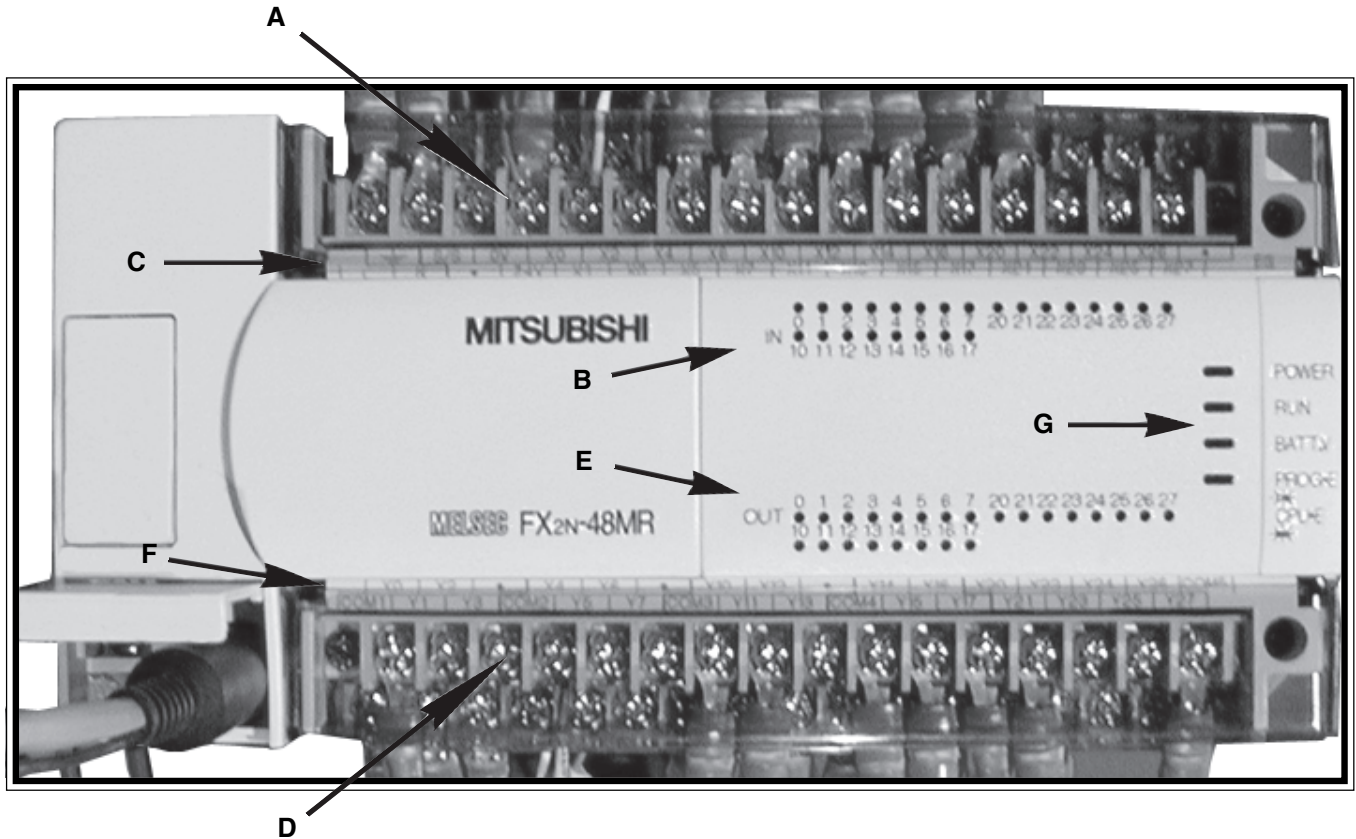

- |                                   |                                    |
|-----------------------------------|------------------------------------|
| A - input terminals               | E - output indicating LED 's       |
| B - input indicating LED's        | F - output terminal identification |
| C - input terminal identification | G - PLC status indicator lights    |
| D - output terminals              |                                    |

**Input and output terminal identification** : - the top row of identification labels corresponds to the top row of terminals and the bottom row of labels to the bottom row of terminals.

Input and Output LED numbers correspond to the Input or Output of the same number.  
ie. Input LED #0 corresponds to Input X0 . Output LED #0 corresponds to Output Y0

**PLC Status indicators** :

- Power - on when power exists to the PLC
- Run - on when the PLC is running
- Batt V - on when PLC memory backup battery has low voltage condition
- Prog E - on when PLC has a program error.

## Input / Output Terminal Information

<p><b>Inputs -</b></p> <ul style="list-style-type: none"> <li>X0 - Shuttle Encoder, Channel A</li> <li>X1 - Shuttle Encoder, Channel B</li> <li>X2 - Blade Speed</li> <li>X3 - Feed rate encoder A</li> <li>X4 - Feed rate encoder B</li> <li>X5 - Head Lower L/S</li> <li>X6 - Coolant Switch</li> <li>X7 - Coolant Switch</li> </ul>	<ul style="list-style-type: none"> <li>X10 - Shuttle Vise Close Switch</li> <li>X11 - Shuttle Vise Open Switch</li> <li>X12 - Front Vise Close Switch</li> <li>X13 - Front Vise Open Switch</li> <li>X14 - Head Raise Switch</li> <li>X15 - Head Lower Switch</li> <li>X16 - Blade Start</li> <li>X17 - Cycle Start</li> <li>X20 - Blade Stop P/B</li> <li>X21 - Out of Stock (Option)</li> <li>X22 - Head Raise L/S</li> </ul>
<p><b>Outputs -</b></p> <ul style="list-style-type: none"> <li>Y0 - Machine Latch</li> <li>Y1 - Open</li> <li>Y2 - Open</li> <li>Y3 - Blade Run Pilot Light</li> <li>Y4 - VFD Start</li> <li>Y5 - VFD Stop / Reset</li> <li>Y6 - Open</li> <li>Y7 - Open</li> </ul>	<ul style="list-style-type: none"> <li>Y10 - Front Vise Close</li> <li>Y11 - Front Vise Open</li> <li>Y12 - Shuttle Fast</li> <li>Y13 - Blade Motor Contactor</li> <li>Y14 - Shuttle Rev</li> <li>Y15 - Shuttle Fwd</li> <li>Y16 - Head Raise</li> <li>Y17 - Head Lower</li> <li>Y20 - Shuttle Vise Close</li> <li>Y21 - Shuttle Vise Open</li> <li>Y22 - Coolant Pump On / Off</li> <li>Y23 - Cycle On Pilot Light</li> </ul>

## ENCODER and PROXIMITY SENSOR CONNECTIONS

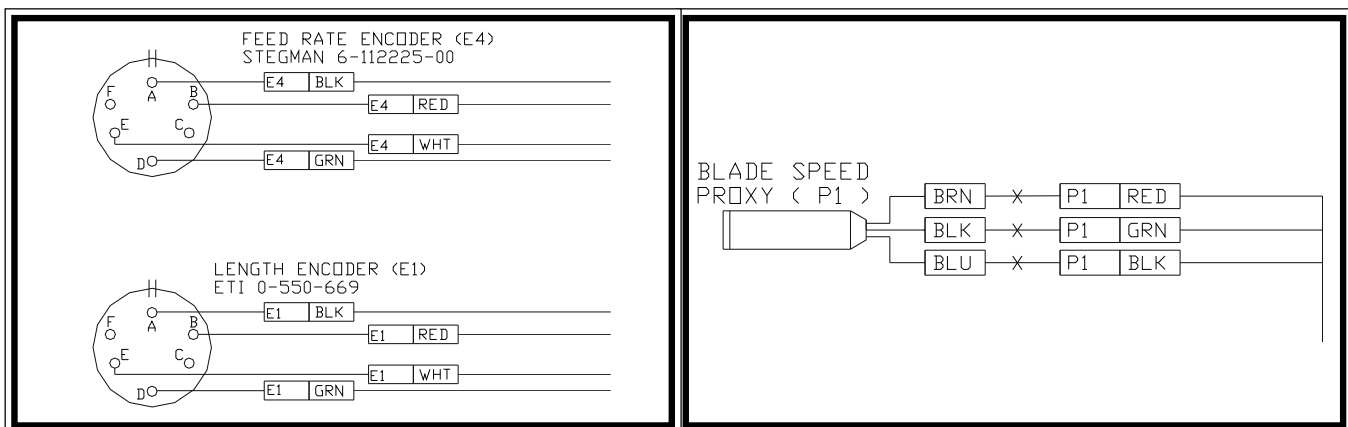

---

## **CALIBRATION PROCEDURE**

### **FOR MITSUBISHI PLC with 2100 series software**

Length calibration may be achieved in two ways: by inputting "ACTUAL LTH" (actual length) or "LTH CONST" (length constant) parameter.

To determine "Actual LTH" value, the "LTH CLB" (length calibration) procedure must be executed.

In manual mode position a piece of material which is longer than the shuttle full stroke length (i.e.S20A=29.00") and close the front VISE. Simultaneously depress "FWD" & "REV" buttons on the PLC to access parameters. A password is required at this point which can be obtained from Hyd·Mech Service Department.

#### **SCREEN WILL DISPLAY:**



```
LTH CLB PRESS ENTER
ACTUAL LTH - 33.085"
LTH CONST 0.001256
ACCEL DIST 0.250"
```

With the cursor @ shown position (as illustrated above) press . The cycle start button will then start to flash & "ENTER" will change to "ON" indication self-calibration mode. Start the blade and the trim cut will be made. After the trim cut is made the head will rise, the shuttle will retract fully in slow speed, clamp the material and come fully forward in slow speed to the home position and make a cut. After the cut is complete "ON" will change back to "PRESS ENTER". Measure the cut part length.

Move cursor down to "ACTUAL LTH" and enter length of cut part plus the actual kerf value. Then exit the parameters by pressing the AUTO/MAN key (the cycle start button will stop flashing). To determine if the encoder channels are connected correctly, observe the actual length parameter for the sign only during shuttle retraction in calibration mode. If the actual length value shows as a negative number, then the channels must be reversed and the calibration procedure repeated.

To determine "LTH CONST" value, use this formula;

$$\text{LTH CONST} = \text{ENCODER PINION CIRCUMFERENCE (TTd)} \div \text{ENCODER RESOLUTION}$$

Example;

For a 1" pinion diameter and 2500 PPR encoder:

$$\text{LTH CONST} = \text{TTd} \div 2500 \text{ PPR} = 0.001257$$

**\*NOTE:** When first entering the parameters screen if not running the self calibration do not use the enter key but use the cursor keys to scroll through the parameters.

#### **To check length control consistency:**

- 1) Perform test cuts of three different lengths (i.e. 1", 12", 20") and measure as accurately as possible with a Vernier or dial caliper.
- 2) If the measurements indicate a linear problem (measured length error increases as the programmed length increases), the "ACTUAL LGTH" or "LTH CONST" value will have to be adjusted.

**To adjust "ACTUAL LGTH" value** The Length Calibration Procedure **MUST** be performed. This may be done with material in the machine (cut and measure material length) or with no material in the machine (let machine complete the calibration cycle, then enter new value).

- If part length error gets longer as the programmed length increases; ACTUAL LTH value should be increased.
- If part length error gets shorter as the programmed length increases; ACTUAL LTH value should be decreased.
- Make small adjustments at a time (i.e. .020" - .030") and recheck with test cuts.

---- Continued ----

**To adjust “LTH CONST”, follow this procedure;**

Cut length ÷ Programmed length X Existing “LTH CONST” = New “LTH CONST”

Example;

Cut length of 11.998”, Programmed length of 12”, Existing “LTH CONST” parameter of 0.001256.

11.988 ÷ 12.000 X 0.001256 = 0.001255

The new “LTH CONST” value of 0.001255 should be entered as the “LTH CONST” parameter and test cuts repeated. Adjust the parameter again if necessary.

**General rule:** Lowering the “LTH CONST” value = Longer shuttle travel = Longer parts.  
Increasing the “LTH CONST” value = Shorter shuttle travel = Shorter parts.

### **HEAD HEIGHT CALIBRATION PROCEDURE**

**NOTE:** On "M" machines remove the head up limit switch target to prevent damage of the head up limit switch during calibration.

Head calibration may be achieved in two ways: by inputting “ACTUAL HGT” (actual height) or “HGT CONST” (height constant) parameter.

To determine “Actual HGT” value, the “HGT CLB” (height calibration) procedure must be executed.

- 1) Enter the PLC parameter screen as per Length Calibration Procedure above.
- 2) Using the arrow cursor keys scroll down until the screen displays :

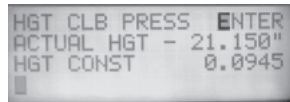

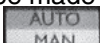

3) With the cursor on the word “ENTER”, press the  key. The cycle start button will begin to flash, the “ENTER” will change to “ON” (indicating self calibration mode) and the head will move to it's down limit and then will move up to it's full upper limit.

4) Measure the distance from the vise horizontal wear strip to the blade teeth tips, and enter this value in the ACTUAL HGT parameter. Measurement must be made along the front vise datum jaw. Input this measurement value & press the  key. Press the  key to finish the procedure & exit the parameters screen.

**NOTE;** To determin if the encoder channels are connected, observe the actual height value parameter for the sign during head up movement only while in calibration mode. If the actual height value shows as a negative number, the channels must be reversed and the calibration procedure repeated.

To determine “HGH CONST” value, use this formula;

ACTUAL FEED RATE | Displayed FEED RATE x HGT CONST = new HGT CONST.

- 5) Input new HGT CONST & press .
- 6) Press  key to exit the parameters screen.



---

## ***SECTION 4, ELECTRICAL SYSTEM***

### ***GENERAL INFORMATION***

This machine has been built to the customers requirements, however, if any voltage changes are required, consult Hyd-Mech service department before implementing any changes.

### ***INITIAL HOOKUP***

At initial hook-up it is important to check that the phase order is correct. This is indicated by the blade drive wheel revolving in a counter clockwise direction and the hydraulic pressure gauge registering a pressure rise. On the following pages are the electrical schematics and physical wiring diagrams along with a list and photos of electrical components.

**NOTE:** 1)The PLC is equipped with a lithium battery to keep the program stored while the power is shut down. The battery will need to be replaced every 3 to 5 years, depending on usage. A visual warning will be displayed on the interface when the battery drains to a certain level. Batteries can be purchased through your Hyd-Mech Distributor.

2) If the machine is equipped with an inverter, do not turn disconnect on for 3 three minutes after disconnect has been shut off. Cycling power sooner than 3 minutes will result in damage to the Variable Frequency Drive.

3) All of the machines equipped with a Mitsubishi PLC have a snap on Ferrite core on the interface cable. This is placed near the interface in order to reduce "noise".

**ELECTRICAL COMPONENTS, PHOTOS**

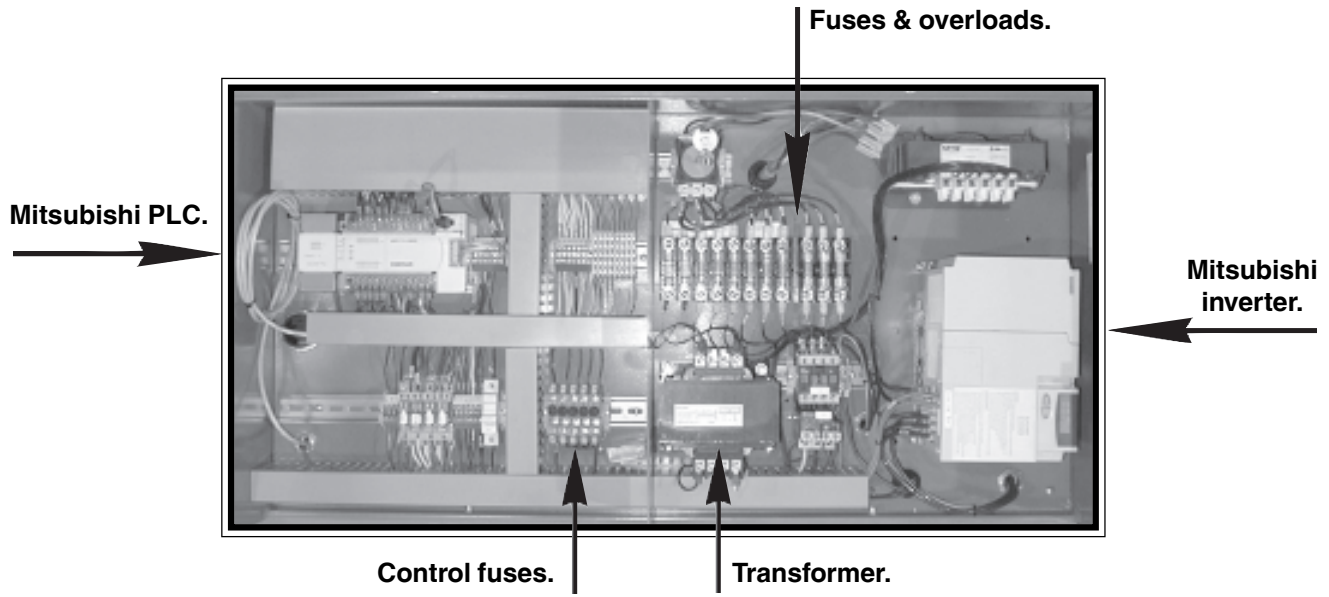

**Electrical control box layout.**

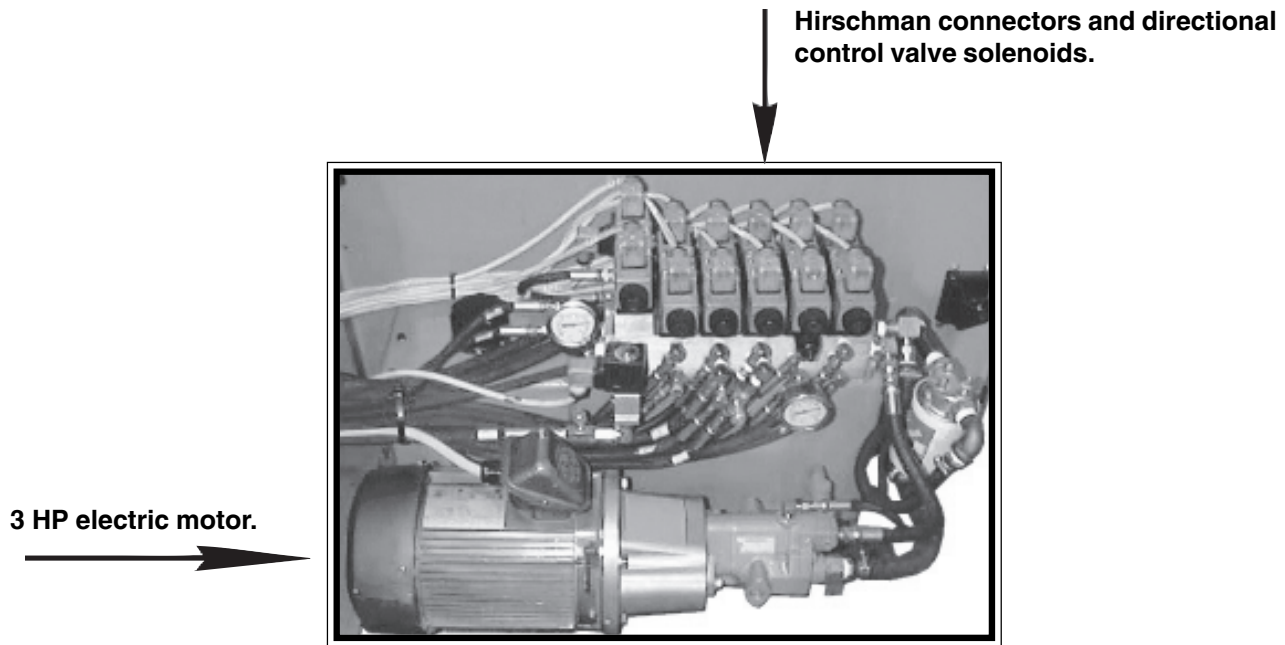

**Hydraulic control components.**

## ELECTRICAL COMPONENTS LISTS

<b>LIST OF H18A SV H22A ELECTRICAL COMPONENTS</b>			
<i>Item Code as on H22A Schematic</i>	<i>Description</i>	<i>Part Number</i>	<i>Component Manufacturer</i>
1PB-Emergency Stop Push Button	Red mushroom head, latching push button. Mounting base with 1 N/C contact block.	ZB2 BT4 ZB2 BZ102	Telemecanique Telemecanique
2PB-Hydraulic Start Push Button	Green, illuminated, flush head push button. Light module with 1 N/O contact block plus 130V (BA9s) light bulb.	ZB2 BW33 ZB2 BW061 SP105	Telemecanique Telemecanique Spectro
3PB-Cycle Start Push Button	White, illuminated, flush head push button. Light module with 1 N/O contact block & 130V (BA9s) light bulb.	ZB2 BW31 ZB2 BW061 SP105	Telemecanique Telemecanique Spectro
4PB-Blade Stop Push Button	Black, non-illuminated, flush head push button. Mounting base with 1 N/C contact block.	ZB2 BA2 ZB2 BZ102	Telemecanique Telemecanique
5PB-Blade Start Push Button	Green, illuminated, flush head push button Light module with 1 N/O contact block and 130V (BA9s) light bulb.	ZB2 BW33 ZB2 BW061 SP105	Telemecanique Telemecanique Spectro
1SS-Coolant Selector Switch	Black, 3 positions, maintained selector switch. Mounting base with 2 N/O contact blocks.	ZB2 BD3 ZB2 BZ103	Telemecanique Telemecanique
2SS-Shuttle Vise Selector Switch	Black, 1 position spring return from left to center & 1 position maintained to right s/s. Mounting base with 2 N/O contact blocks plus 1 N/C contact.	ZB2 BD7 ZB2 BZ103 ZB2 BE102	Telemecanique Telemecanique Telemecanique
3SS-Front Vise Selector Switch	Black, 1 position spring return from left to center & 1 position maintained to right s/s. Mounting base with 2 N/O contact blocks plus 1 N/C contact.	ZB2 BD7 ZB2 BZ103 ZB2 BE102	Telemecanique Telemecanique Telemecanique
4SS-Head Selector Switch	Black, 3 positions, maintained selector switch. Mounting base with 2 N/O contact blocks plus 2 N/C contact blocks.	ZB2 BD3 ZB2 BZ103 ZB2 BE102	Telemecanique Telemecanique Telemecanique
5SS-Blade Tension Selector Switch	Black, 3 positions, maintained selector switch. Mounting base with 2 N/O contact blocks and Mounted in plastic enclosure (black/yellow).	XALJ133	HMG
6SS-Guide Arm Selector Switch (H22A only)	Black, 2 positions, spring return to center selector switch. Mounting base with 2 N/O contact blocks.	ZB2 BD5 ZB2 BZ103	Telemecanique Telemecanique
7SS-Work Lamp Selector Switch	Black, 2 positions maintained selector switch. Mounting base with 1 N/O contact block.	ZB2 BD2 ZB2 BZ102	Telemecanique Telemecanique
1BS -Blade Speed	1 K ohm Potentiometer	KU1021S20	HMG

## LIST OF H18 SV\_H22A ELECTRICAL COMPONENTS

<i>Item Code as on H18 + H22 Schematic</i>	<i>Description</i>	<i>Part Number</i>	<i>Component Manufacturer</i>
FX2N-48MR	Mitsubishi PLC.	FX2N-48MR	Mitsubishi
E200	Mitsubishi Interface	E200	Mitsubishi
	Interface communication cable	H22-FX2N32-009	HMG
	Ferrite core	444164951	Ferrite
Hyd. Valve Connector	Hirschmann connector	H/927811311	Hirschmann
6CR	Coolant pump relay plus mounting base.	G2R-2-S P2RF-08-E	Omron
1FU	Fuse holder 5A Time-delay fuse	USM1 ATDR5	Gould
6FU	Fuse holder for "power" into PLC 2A Instant glass fuse	WK10/Si AGC-2	Wieland Buss
5FU1 - 5FU4	Fuse holder for PLC outputs 3A Time Delay glass fuse	WK10/Si MDL-3	Wieland Buss
1 L/S Head up	Limit switch with roller lever	XCK L115H7	Telemecanique
2 L/S Head Down	Limit switch with roller lever	XCK L115H7	Telemecanique
4 L/S Out Of Stock	Limit switch with roller lever	XCK L115H7	Telemecanique
P1 - Blade Speed	Proximity switch c/w washer & nut (NPN - N0)	DCA12/4608KS	Burgess-Saia
E1	Incremental encoder for length count (2500 PPR)	H2098017	ETI
E4	Incremental encoder for feed rate count.(8192 PPR)	6-112225-00	Stegmann
Fan	Hydraulic component cooling fan	28316	Muffin
Coolant Pump	Coolant pump 1 Phase /120 VAC	3E-NT	Little Giant
	Coolant Pump Junction Box	SCEJB442	HMG
	Wire terminal 20-10 AWG	WK4/U	Wieland
	Wire terminal 20-8 AWG	WK6/U	Wieland
	Wire terminal 16-6 AWG	WK10/U	Wieland
	Double ground terminal 20-8 AWG	WK4/D2/2SLU	Wieland
	Ground terminal 16-6 AWG	WK10/U	Wieland
	Suppressor	SSQUENCHO1	HMG
	R-C Suppressor Quenchark	504M02QA100	Quenchark
<b>Options</b>			
8SS-Auxiliary Vise Selector Switch	Black, 1 position spring return from left to center & 1 position maintained to right s/s. Mounting base with 2 N/O contact blocks plus 1 N/C contact.	ZB2 BD7 ZB2 BZ103 ZB2 BE102	Telemecanique Telemecanique Telemecanique
5FU5	Fuse holder for PLC output ( for Auxiliary Vise option ) 3A Time Delay glass fuse	WK10/Si MDL-3	Wieland Buss
15SS-Laser Guide Selector Switch.	Black, 2 positions maintained selector switch. Mounting base with 1 N/O contact block.	ZB2 BD2 ZB2 BZ102	Telemecanique Telemecanique
26SS-Oil Heater Selector Switch.	Black, 2 positions maintained selector switch. Mounting base with 1 N/O contact block.	ZB2 BD2 ZB2 BZ102	Telemecanique Telemecanique

### H18A SV POWER COMPONENTS for SPECIFIC VOLTAGES

Description & (Item Code) as on schematic	MACHINE VOLTAGE						Component Manufacturer
	3ph 208V	3ph 240V	3ph 380	3ph 415V	3ph 480V	3ph 600V	
<b>3HP HYDRAULIC PUMP MOTOR (1M) Frame Size 182TC, 1800 R.P.M.</b>							
CONTACTOR (1M)	LC1D1210G6	LC1D1210G6	LC1D1210G6	LC1D1210G6	LC1D1210G6	LC1D1210G6	Telemecanique
THERMAL OVERLOAD (1 O/L)	LR2D1314	LR2D1314	LR2D1310	LR2D1310	LR2D1310	LR2D1308	Telemecanique
MOTOR F.L.A. (1750 RPM)	8.6 A	8.0 A	4.8 A	4.6 A	4.0 A	3.5 A	
FUSE SIZE & FUSE HOLDER PART # (3FU1, 3FU2, 3FU3)	20A T.D ATDR20 30310	20A T.D ATDR20 30310	10A T.D ATDR10 USM3	10A T.D ATDR10 USM3	10A T.D ATDR10 30310	8A T.D ATDR8 30310	Gould
<b>10HP INVERTER &amp; 10HP BLADE DRIVE MOTOR (2M) Frame Size 286TC, 1200 R.P.M.</b>							
INVERTER PART # & INPUT CURRENT	FR-E520-7.5K -NA 31.3A	FR-E520-7.5K-NA 28.3A	FR-E540-7.5K-NA 17.5A	FR-E540-7.5K-NA 15.9A	FR-E540-7.5K-NA 14.1A	FR-A560-7.5K-NA 11.4A	Mitsubishi
2M CONTACTOR	LC1D5011	LC1D5011	LC1D2510	LC1D2510	LC1D1810	LC1D1210	
FUSE SIZE & FUSE HOLDER PART # (4FU1, 4FU2, 4FU3)	50A T.D AJT50 60608J	45A T.D AJT45 60608J	35A T.D ATDR35 USM3	30A T.D ATDR30 USM3	30A T.D ATDR30 303103	20A T.D ATDR20 30310	Gould
<b>CONTROL TRANSFORMER (TR) 750 VA</b>							
TRANSFORMER PART # (TR)	9070 T750D3	9070 T750D1	9070 T750D33	9070 T750D33	9070 T750D1	9070 T750D5	Square-D
PRIMARY FUSE SIZE & FUSE HOLDER PART # (2FU1, 2FU2)	12A Fast Acting, ATM12 30310	12A Fast Acting, ATM12 30310	10A Fast Acting, ATM10 USM1	10A Fast Acting, ATM10 USM1	8A Fast Acting, ATM8 30310	8A Fast Acting, ATM8 30310	Gould
SECONDARY FUSE SIZE & FUSE HOLDER PART # (1FU)	8A T.D ATDR8 30310	8A T.D ATDR8 30310	8A T.D ATDR8 USM1	8A T.D ATDR8 USM1	8A T.D ATDR8 30310	8A T.D ATDR8 30310	Gould
LINE REACTOR PART # (480 575 VAC ONLY)	-	-	-	-	MTE RL-01803	MTE RL-01203	MTE Corporation
DISCONNECT RATING (A) & PART #	83A VCCF4	83A VCCF4	40A VCCF2	40A VCCF2	25A VCCF2	25A VCCF2	Telemecanique

**ELECTRICAL SCHEMATIC and WIRING DRAWINGS**

208 - 240 volt power schematic

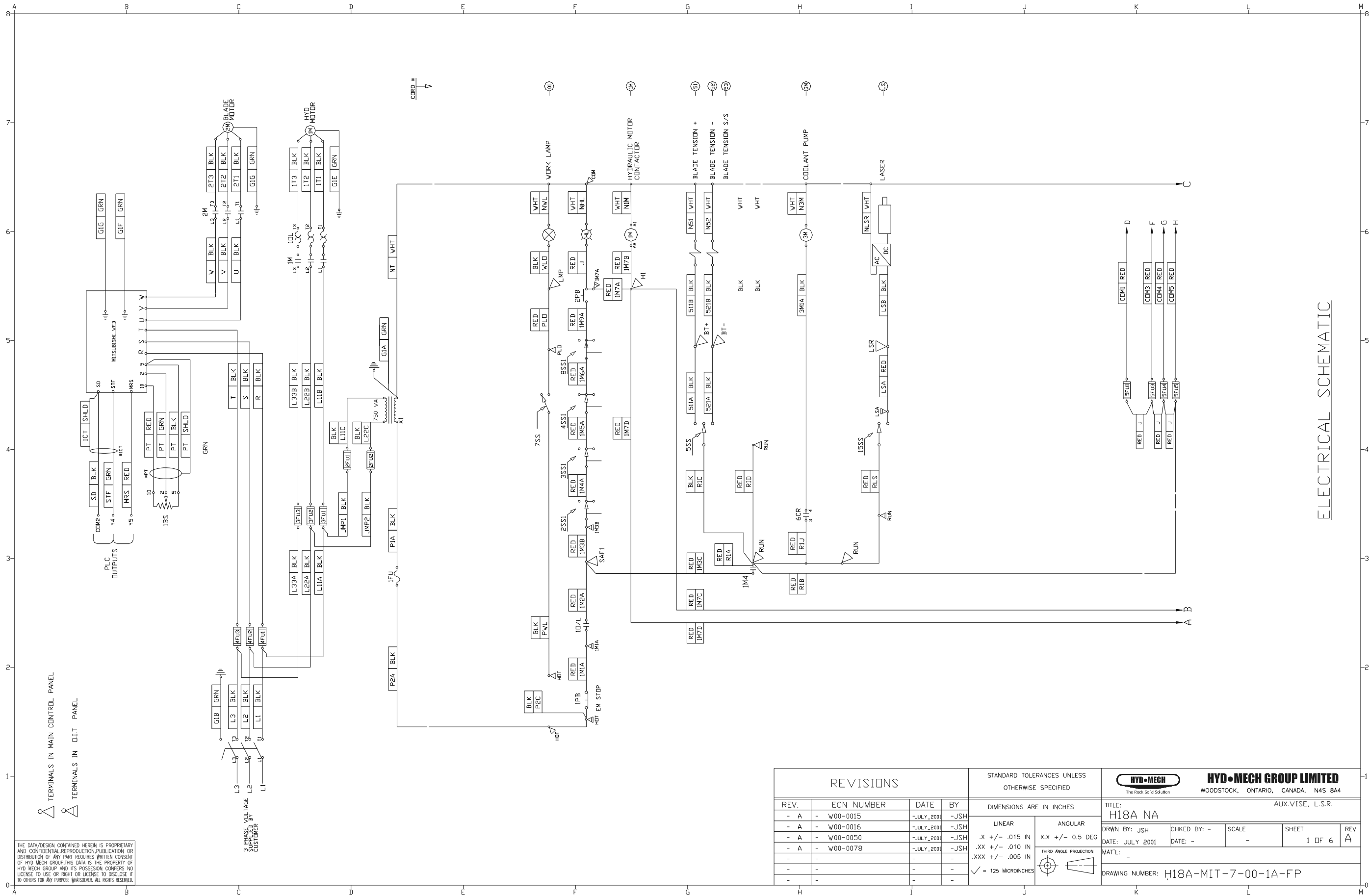

ELECTRICAL SCHEMATIC

REVISIONS				STANDARD TOLERANCES UNLESS OTHERWISE SPECIFIED		HYD-MECH GROUP LIMITED	
REV.	ECN NUMBER	DATE	BY	DIMENSIONS ARE IN INCHES		AUX.VISE, L.S.R.	
- A	- W00-0015	-JULY_2001	-JSH	LINEAR		TITLE: H18A NA	
- A	- W00-0016	-JULY_2001	-JSH	ANGULAR		DRWN BY: JSH	
- A	- W00-0050	-JULY_2001	-JSH	.X +/- .015 IN		CHKD BY: -	
- A	- W00-0078	-JULY_2001	-JSH	.XX +/- .010 IN		SCALE: -	
-	-	-	-	.XXX +/- .005 IN		SHEET: 1 OF 6	
-	-	-	-	✓ = 125 MICRINCHES		REV: A	
-	-	-	-	THIRD ANGLE PROJECTION		DATE: JULY 2001	
-	-	-	-			DRAWING NUMBER: H18A-MIT-7-00-1A-FP	

TERMINALS IN MAIN CONTROL PANEL  
TERMINALS IN D.I.T. PANEL

PLEASE CONTACT SUPPLIER FOR CUSTOMER

THE DATA/DESIGN CONTAINED HEREIN IS PROPRIETARY AND CONFIDENTIAL. REPRODUCTION, PUBLICATION OR DISTRIBUTION OF ANY PART REQUIRES WRITTEN CONSENT OF HYD-MECH GROUP. THIS DATA IS THE PROPERTY OF HYD-MECH GROUP AND ITS POSSESSION CONFERS NO LICENSE TO USE OR RIGHT OR LICENSE TO DISCLOSE IT TO OTHERS FOR ANY PURPOSE WHATSOEVER. ALL RIGHTS RESERVED.

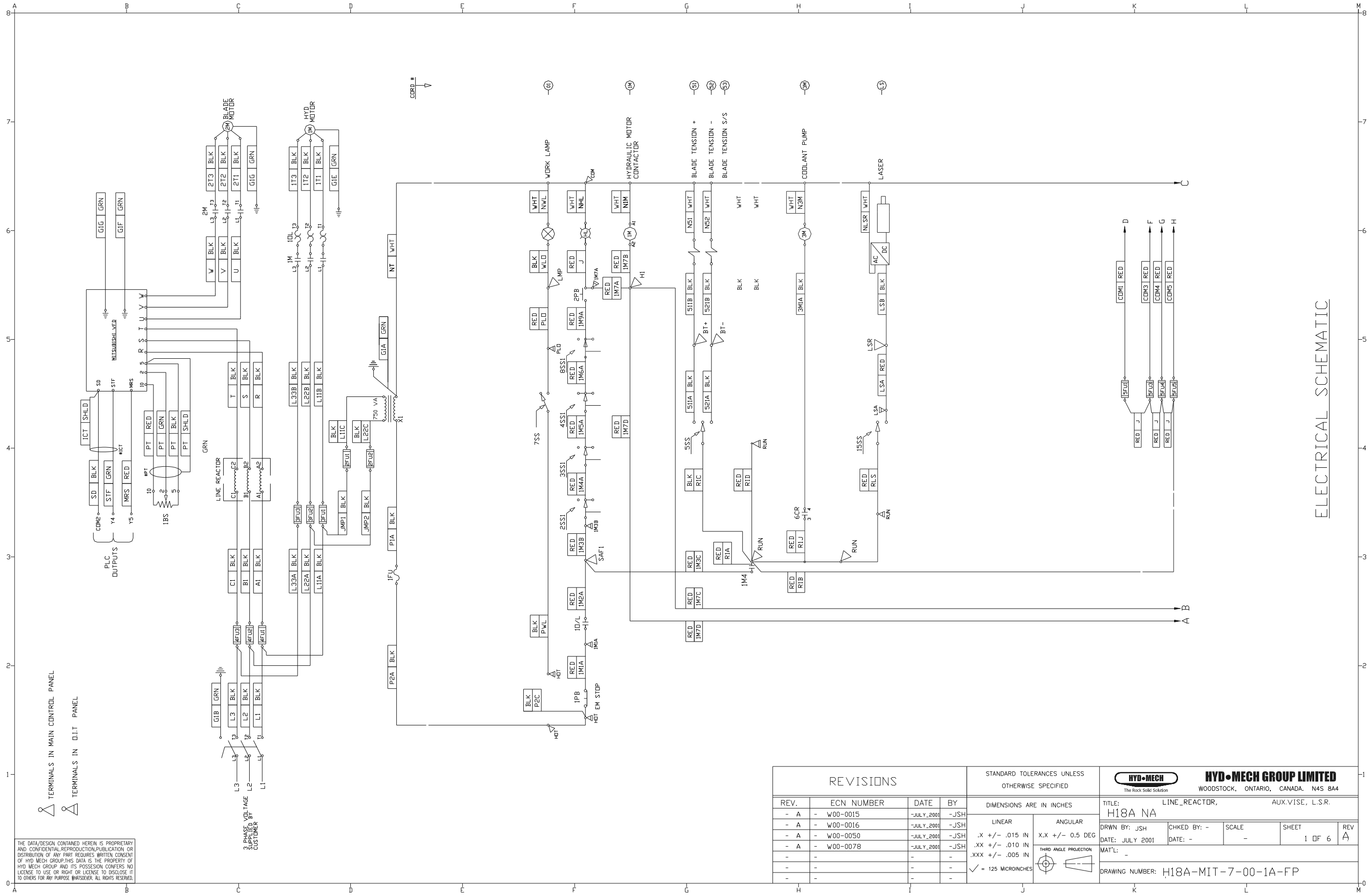

ELECTRICAL SCHEMATIC

REVISIONS				STANDARD TOLERANCES UNLESS OTHERWISE SPECIFIED		HYD-MECH GROUP LIMITED	
REV.	ECN NUMBER	DATE	BY	DIMENSIONS ARE IN INCHES		TITLE: LINE_REACTOR, AUX.VISE, L.S.R.	
- A	- W00-0015	-JULY_2001	-JSH	LINEAR	ANGULAR	DRAWN BY: JSH	
- A	- W00-0016	-JULY_2001	-JSH	.X +/- .015 IN	X.X +/- 0.5 DEG	DATE: JULY 2001	CHKD BY: -
- A	- W00-0050	-JULY_2001	-JSH	.XX +/- .010 IN		SCALE: -	SHEET: 1 OF 6
- A	- W00-0078	-JULY_2001	-JSH	.XXX +/- .005 IN		DATE: -	REV: A
-	-	-	-	✓ = 125 MICRONS	THIRD ANGLE PROJECTION	DRAWING NUMBER: H18A-MIT-7-00-1A-FP	

TERMINALS IN MAIN CONTROL PANEL  
 TERMINALS IN D.I.T. PANEL

THE DATA/DESIGN CONTAINED HEREIN IS PROPRIETARY AND CONFIDENTIAL. REPRODUCTION, PUBLICATION OR DISTRIBUTION OF ANY PART REQUIRES WRITTEN CONSENT OF HYD-MECH GROUP. THIS DATA IS THE PROPERTY OF HYD-MECH GROUP AND ITS POSSESSION CONFERS NO LICENSE TO USE OR RIGHT OR LICENSE TO DISCLOSE IT TO OTHERS FOR ANY PURPOSE. #W/ISS/VER. ALL RIGHTS RESERVED.

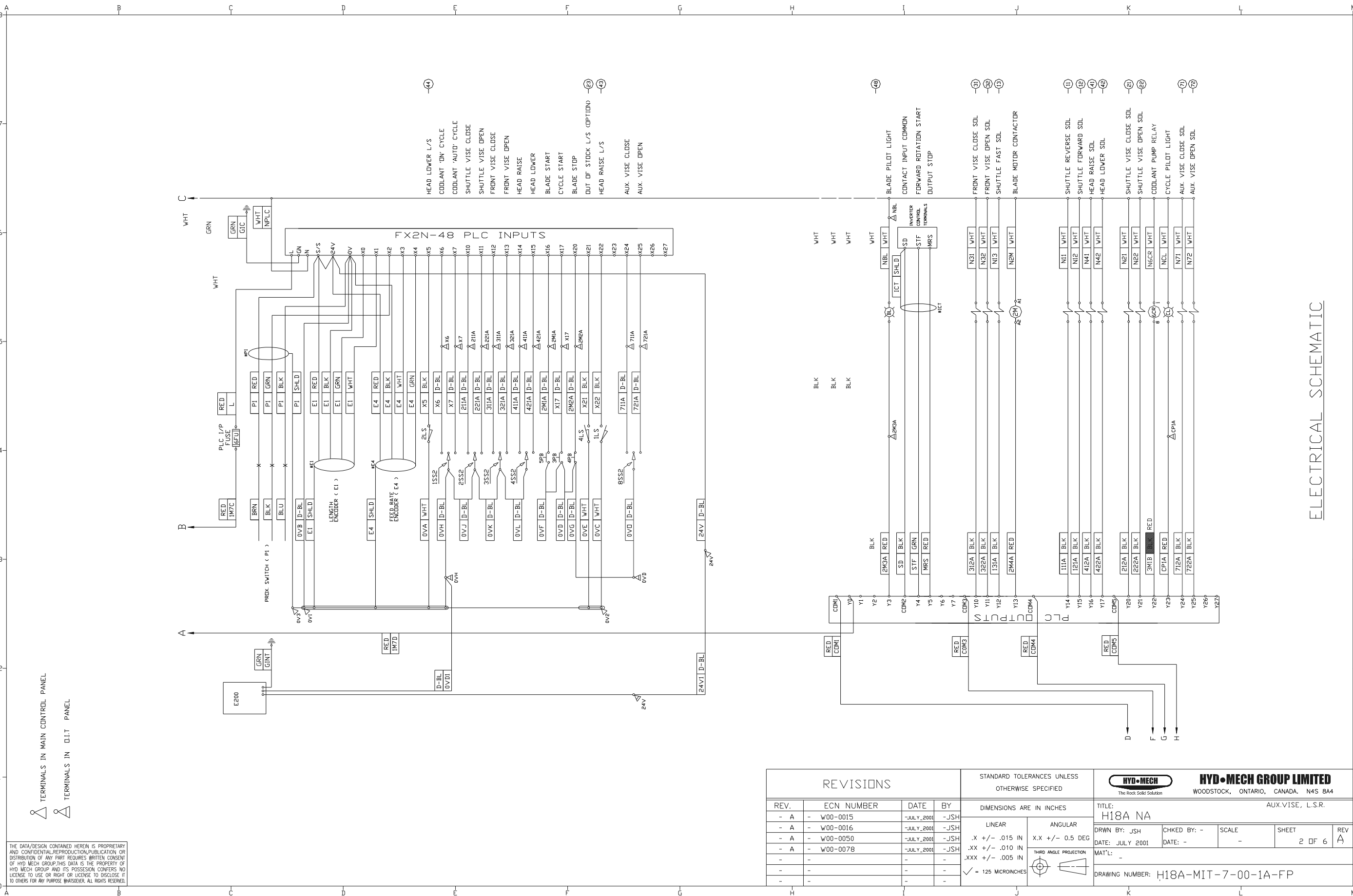

ELECTRICAL SCHEMATIC

TERMINALS IN MAIN CONTROL PANEL  
 TERMINALS IN O.I.T. PANEL

THE DATA/DESIGN CONTAINED HEREIN IS PROPRIETARY AND CONFIDENTIAL. REPRODUCTION, PUBLICATION OR DISTRIBUTION OF ANY PART REQUIRES WRITTEN CONSENT OF HYD-MECH GROUP. THIS DATA IS THE PROPERTY OF HYD-MECH GROUP AND ITS POSSESSION CONVEYS NO LICENSE TO USE OR RIGHT OR LICENSE TO DISCLOSE IT TO OTHERS FOR ANY PURPOSE. © 2001 HYD-MECH GROUP. ALL RIGHTS RESERVED.

REVISIONS				STANDARD TOLERANCES UNLESS OTHERWISE SPECIFIED		HYD-MECH GROUP LIMITED	
REV.	ECN NUMBER	DATE	BY	DIMENSIONS ARE IN INCHES		AUX.VISE, L.S.R.	
- A	- W00-0015	- JULY_2001	- JSH	LINEAR	ANGULAR	TITLE: H18A NA	
- A	- W00-0016	- JULY_2001	- JSH	.XX +/- .010 IN	X.X +/- 0.5 DEG	DRWN BY: JSH	CHKD BY: -
- A	- W00-0050	- JULY_2001	- JSH	.XXX +/- .005 IN	THIRD ANGLE PROJECTION	DATE: JULY 2001	SCALE: -
-	-	-	-	✓ = 125 MICRONCHES		DATE: -	SHEET: 2 OF 6
-	-	-	-			REV: A	
-	-	-	-			DRAWING NUMBER: H18A-MIT-7-00-1A-FP	

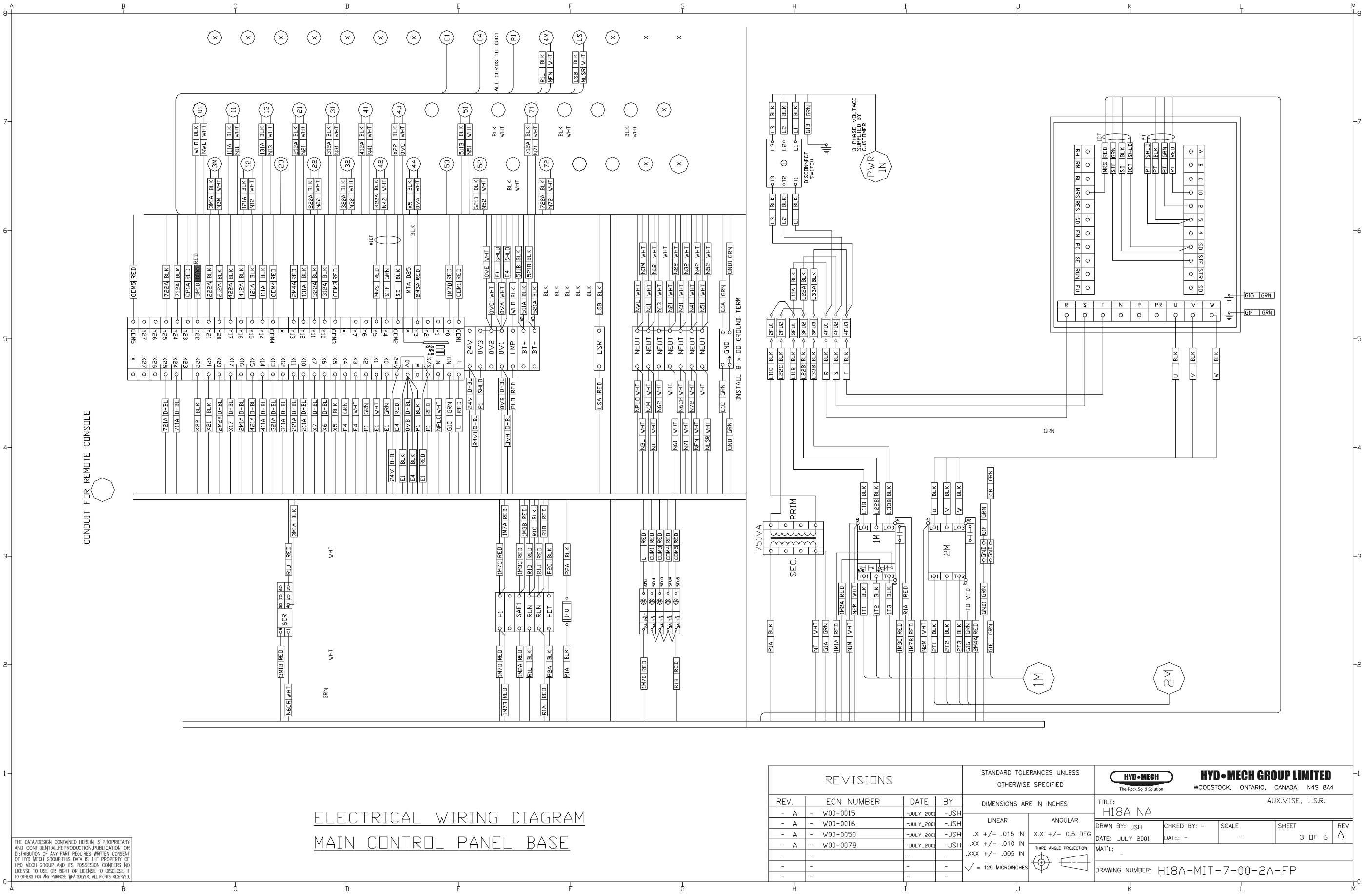

ELECTRICAL WIRING DIAGRAM  
MAIN CONTROL PANEL BASE

REVISIONS				STANDARD TOLERANCES UNLESS OTHERWISE SPECIFIED		HYD-MECH The Rock Solid Solution		HYD-MECH GROUP LIMITED WOODSTOCK, ONTARIO, CANADA, N4S 8A4				
REV.	ECN NUMBER	DATE	BY	DIMENSIONS ARE IN INCHES		TITLE:		AUX.VISE, L.S.R.				
- A	- W00-0015	-JULY_2001	-JSH	LINEAR		H18A NA		DRWN BY: JSH	CHKED BY: -	SCALE	SHEET	REV
- A	- W00-0016	-JULY_2001	-JSH	ANGULAR		DATE: JULY 2001		DATE: -	-	-	3 OF 6	A
- A	- W00-0050	-JULY_2001	-JSH	.X +/- .015 IN		MAT'L: -		DRAWING NUMBER: H18A-MIT-7-00-2A-FP				
- A	- W00-0078	-JULY_2001	-JSH	.XX +/- .010 IN		THIRD ANGLE PROJECTION						
-	-	-	-	.XXX +/- .005 IN		✓ = 125 MICRONS						

THE DATA/DESIGN CONTAINED HEREIN IS PROPRIETARY AND CONFIDENTIAL. REPRODUCTION, PUBLICATION OR DISTRIBUTION OF ANY PART REQUIRES WRITTEN CONSENT OF HYD-MECH GROUP. THIS DATA IS THE PROPERTY OF HYD-MECH GROUP AND ITS POSSESSION CONFERS NO LICENSE TO USE OR RIGHT OR LICENSE TO DISCLOSE IT TO OTHERS FOR ANY PURPOSE WHATSOEVER. ALL RIGHTS RESERVED.

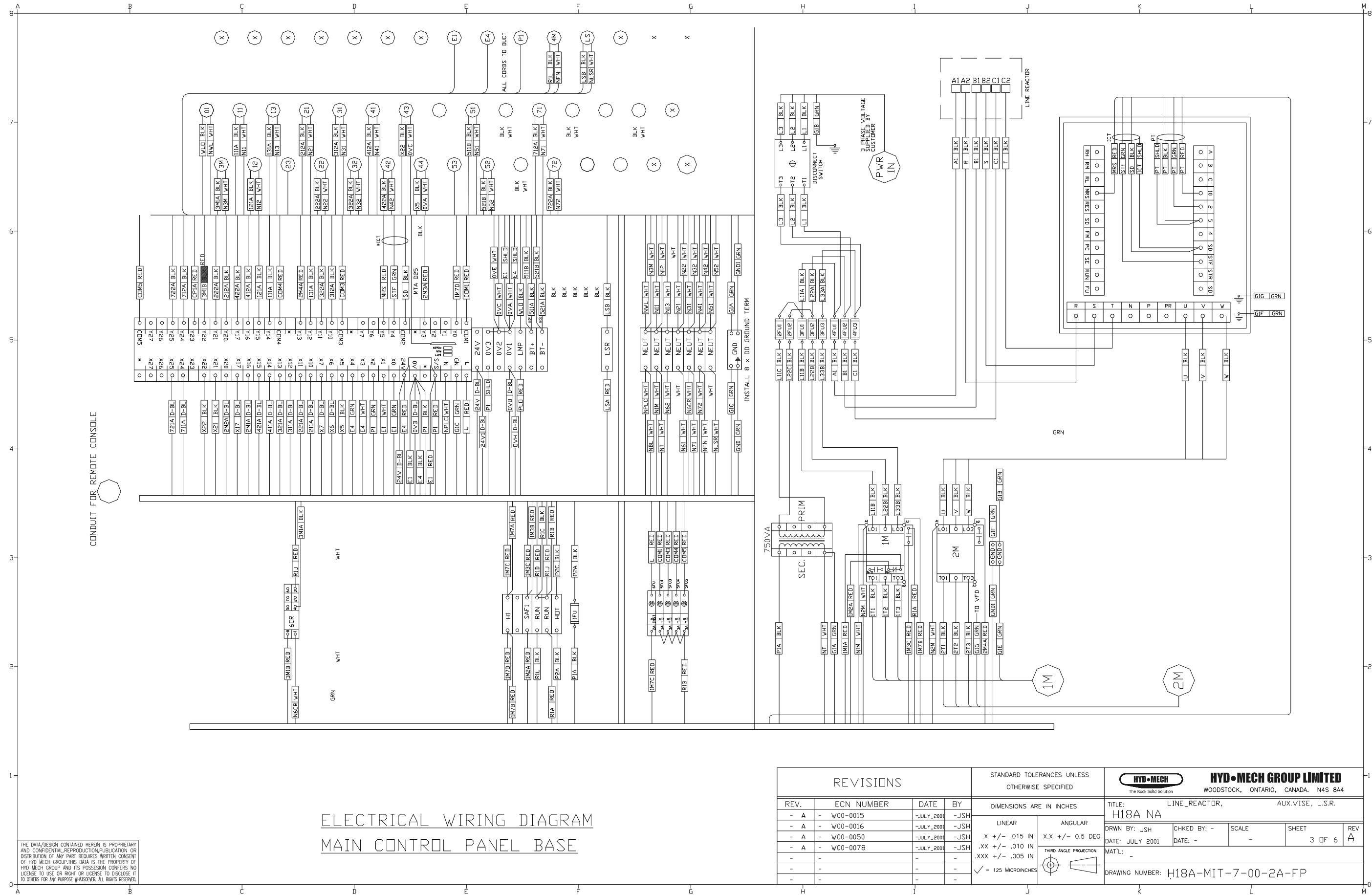

ELECTRICAL WIRING DIAGRAM  
MAIN CONTROL PANEL BASE

THE DATA/DESIGN CONTAINED HEREIN IS PROPRIETARY AND CONFIDENTIAL. REPRODUCTION, PUBLICATION OR DISTRIBUTION OF ANY PART REQUIRES WRITTEN CONSENT OF HYD-MECH GROUP. THIS DATA IS THE PROPERTY OF HYD-MECH GROUP AND ITS POSSESSION CONFERS NO LICENSE TO USE OR RIGHT OR LICENSE TO DISCLOSE IT TO OTHERS FOR ANY PURPOSE. (WHEREVER ALL RIGHTS RESERVED)

REVISIONS			
REV.	ECN NUMBER	DATE	BY
- A	- W00-0015	- JULY_2001	- JSH
- A	- W00-0016	- JULY_2001	- JSH
- A	- W00-0050	- JULY_2001	- JSH
- A	- W00-0078	- JULY_2001	- JSH

STANDARD TOLERANCES UNLESS OTHERWISE SPECIFIED	
DIMENSIONS ARE IN INCHES	
LINEAR	ANGULAR
.X +/- .015 IN	X.X +/- 0.5 DEG
.XX +/- .010 IN	
.XXX +/- .005 IN	
✓ = 125 MICRONS	

		<b>HYD-MECH GROUP LIMITED</b> WOODSTOCK, ONTARIO, CANADA. N4S 8A4	
TITLE: LINE_REACTOR, AUX.VISE, L.S.R.		DRAWN BY: JSH    CHKD BY: -    SCALE: -    SHEET: 3 OF 6    REV: A	
DATE: JULY 2001    DATE: -		MAT'L: -	
DRAWING NUMBER: H18A-MIT-7-00-2A-FP			



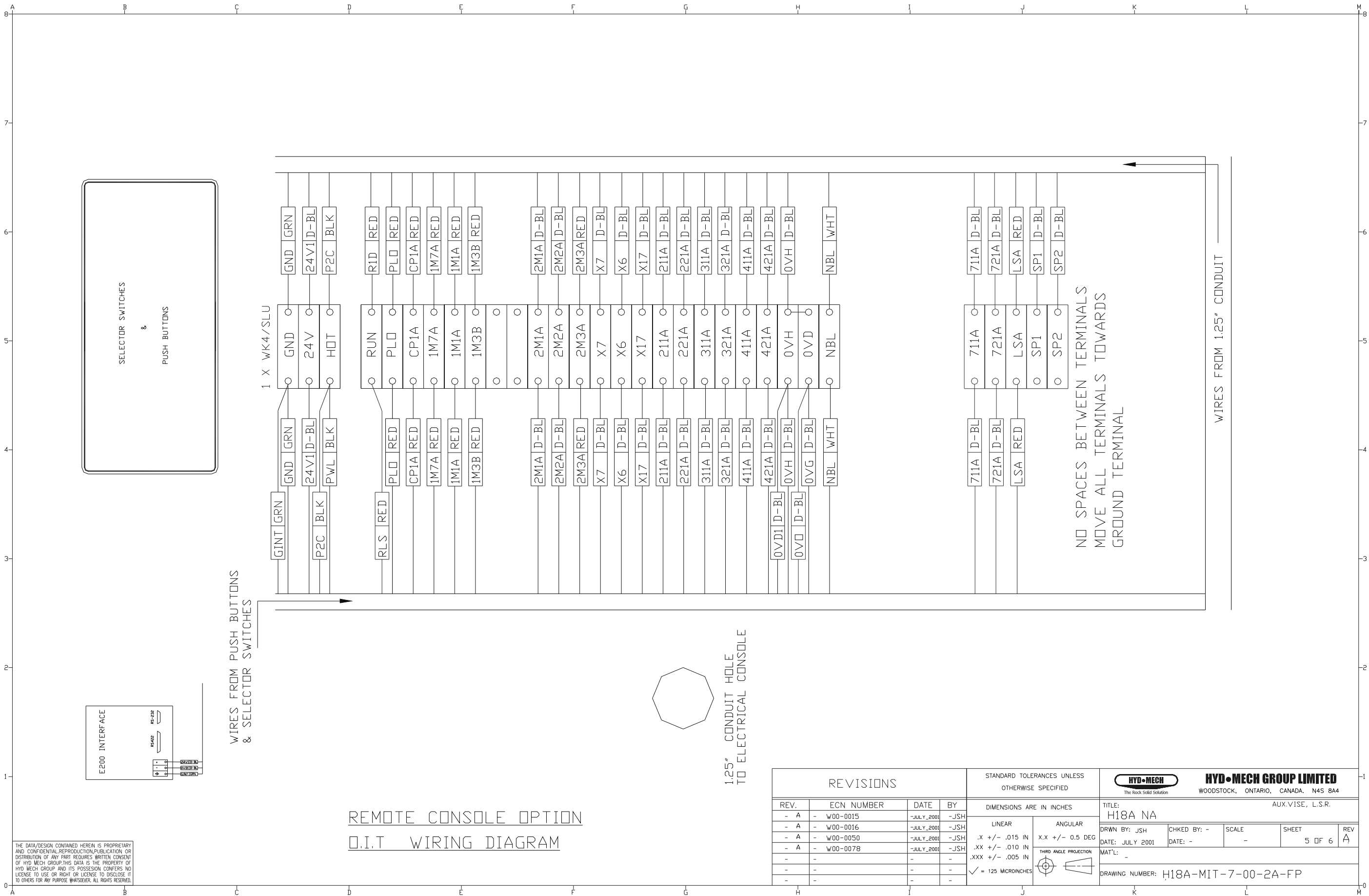

SELECTOR SWITCHES  
&  
PUSH BUTTONS

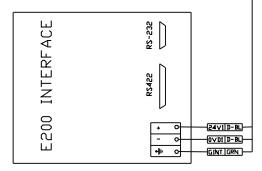

WIRES FROM PUSH BUTTONS  
& SELECTOR SWITCHES

1 X WK4/SLU

REMOTE CONSOLE OPTION  
O.I.T WIRING DIAGRAM

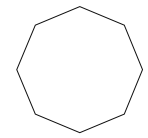

1.25" CONDUIT HOLE  
TO ELECTRICAL CONSOLE

NO SPACES BETWEEN TERMINALS  
MOVE ALL TERMINALS TOWARDS  
GROUND TERMINAL

WIRES FROM 1.25" CONDUIT

REVISIONS				STANDARD TOLERANCES UNLESS OTHERWISE SPECIFIED		HYD-MECH The Rock Solid Solution		HYD-MECH GROUP LIMITED WOODSTOCK, ONTARIO, CANADA. N4S 8A4			
REV.	ECN NUMBER	DATE	BY	DIMENSIONS ARE IN INCHES		TITLE:		AUX.VISE, L.S.R.			
- A	- W00-0015	-JULY_2001	-JSH			H18A NA					
- A	- W00-0016	-JULY_2001	-JSH	LINEAR	ANGULAR	DRWN BY: JSH	CHKD BY: -	SCALE	SHEET	REV	
- A	- W00-0050	-JULY_2001	-JSH	.X +/- .015 IN	X.X +/- 0.5 DEG	DATE: JULY 2001	DATE: -	-	5 OF 6	A	
- A	- W00-0078	-JULY_2001	-JSH	.XX +/- .010 IN		MAT'L:					
-	-	-	-	.XXX +/- .005 IN		DRAWING NUMBER: H18A-MIT-7-00-2A-FP					
-	-	-	-	√ = 125 MICRONCHES	THIRD ANGLE PROJECTION						

THE DATA/DESIGN CONTAINED HEREIN IS PROPRIETARY AND CONFIDENTIAL. REPRODUCTION, PUBLICATION OR DISTRIBUTION OF ANY PART REQUIRES WRITTEN CONSENT OF HYD-MECH GROUP. THIS DATA IS THE PROPERTY OF HYD-MECH GROUP AND ITS POSSESSION CONFERS NO LICENSE TO USE OR RIGHT OR LICENSE TO DISCLOSE IT TO OTHERS FOR ANY PURPOSE WHATSOEVER. ALL RIGHTS RESERVED.

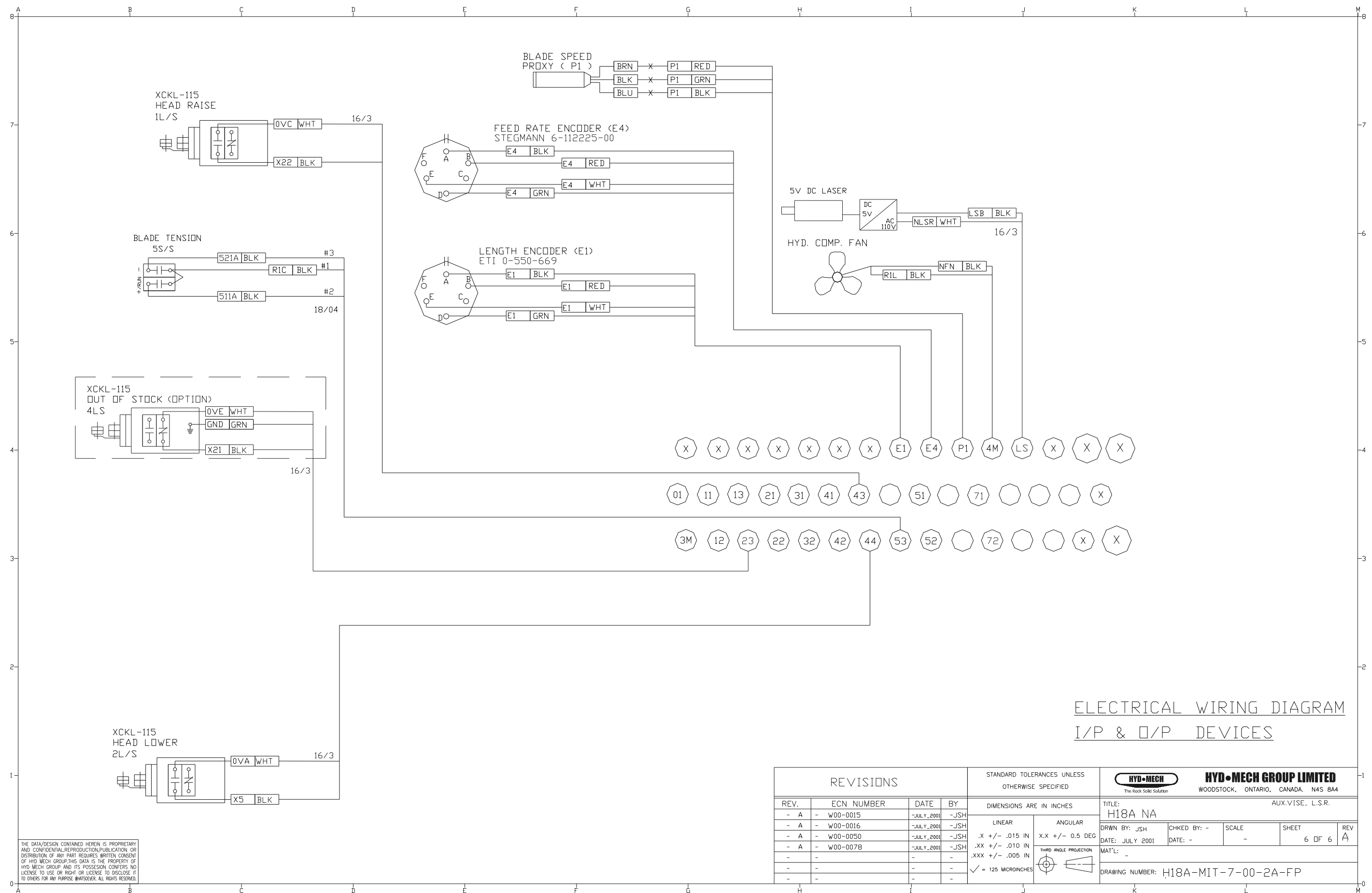

ELECTRICAL WIRING DIAGRAM  
I/P & O/P DEVICES

REVISIONS				STANDARD TOLERANCES UNLESS OTHERWISE SPECIFIED		HYD-MECH GROUP LIMITED WOODSTOCK, ONTARIO, CANADA, N4S 8A4				
REV.	ECN NUMBER	DATE	BY	DIMENSIONS ARE IN INCHES		TITLE: H18A NA AUX.VISE, L.S.R.				
- A	- W00-0015	-JULY_2001	-JSH	LINEAR	ANGULAR	DRWN BY: JSH	CHKD BY: -	SCALE	SHEET	REV
- A	- W00-0016	-JULY_2001	-JSH	.X +/- .015 IN	X.X +/- 0.5 DEG	DATE: JULY 2001	DATE: -	-	6 OF 6	A
- A	- W00-0050	-JULY_2001	-JSH	.XX +/- .010 IN		MAT'L: -				
- A	- W00-0078	-JULY_2001	-JSH	.XXX +/- .005 IN		DRAWING NUMBER: H18A-MIT-7-00-2A-FP				
-	-	-	-	✓ = 125 MICRONS	THIRD ANGLE PROJECTION					

THE DATA/DESIGN CONTAINED HEREIN IS PROPRIETARY AND CONFIDENTIAL. REPRODUCTION, PUBLICATION OR DISTRIBUTION OF ANY PART REQUIRES WRITTEN CONSENT OF HYD-MECH GROUP. THIS DATA IS THE PROPERTY OF HYD-MECH GROUP AND ITS POSSESSION CONFERS NO LICENSE TO USE OR RIGHT OR LICENSE TO DISCLOSE IT TO OTHERS FOR ANY PURPOSE WHATSOEVER. ALL RIGHTS RESERVED.

## **SECTION 5, HYDRAULIC SYSTEM**

The H-18 hydraulic system does not require any special work on a new machine before its start-up. The hydraulic tank is filled with Duro AW46 hydraulic oil and all machine functions have been tested at the factory to ensure proper operation upon initial start-up.

### **HYDRAULIC COMPONENT PARTS LIST**

Quantities in (#) are option quantities.

<b>ITEM</b>	<b>QTY</b>	<b>H-18 PART NUMBER</b>	<b>DESCRIPTION</b>
1	1	MAIN HEAD CYLINDER	H22-C41-00A
2	1	AUX HEAD CYLINDER	H22-C42-00
3	1	SHUTTLE CYLINDER	H14-C1-00A
4	1	DATUM CYLINDER	H22-C22-00
5	1	FT VISE CYLINDER	H18SV-C31-00
6	1	SHT VISE CYLINDER	H22-C31-00A
7	(2)	BUNDLING CYLINDER	H18SV-C23-00
8	(1)	OUTBOARD BUNDLIG CYL	H18SV-G531-00
9	1	BLADE TENSION CYLINDER	S25-C5-00
10	1	MANIFOLD BLOCK	MB6P_A
11	1	DDF VALVE	DDF6-0-00
12	2 (4)	DOUBLE PILOT CHECK VALVE	DPCH-1
13	2 (4)	DIRECTIONAL VALVE	DCV3P-AB-T
14	3 (1)	DIRECTIONAL VALVE	DCV3P-AB-C
15	1	POPET VALVE	PV2P-A-C
16	1	CUSHION BLOCK	CHB-25
17	1	CHIP AUGER MOTOR	HM-01
18	1	PRESSURE REDUCING VALVE	PRV-2
19	1	HYDRAULIC PUMP	HYP-1
20	1	RETURN FILTER ELEMENT	SF 6520
21	1	EXTENSION BLOCK	EB-01 (option)
22	(2)	GRAVITY VALVE	H16-53A-00 (option)
23	1(3)	PRESSURE REDUCING VALVE	PBDP OBN EZ1

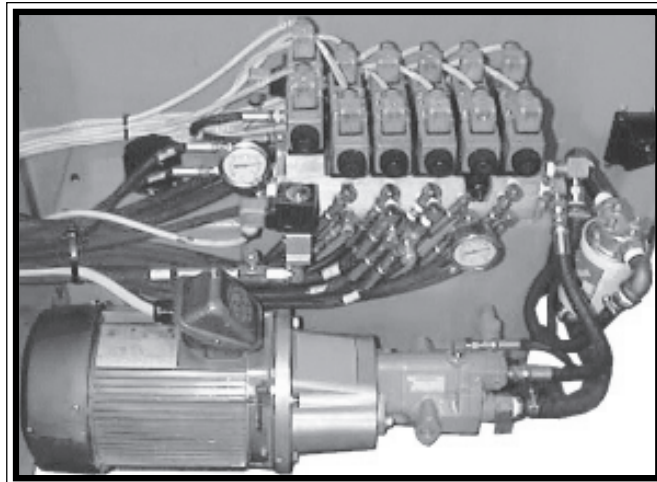

**Hydraulic Manifold & Pump Motor Assembly**

## CYLINDER ASSEMBLIES

### Gland assemblies

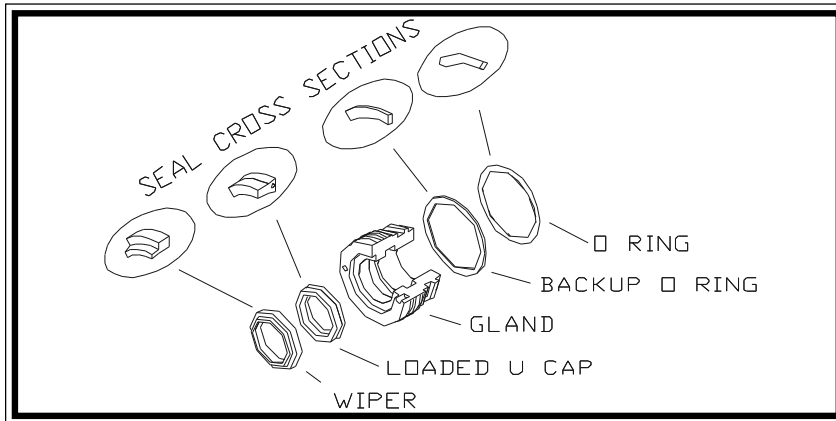

CYLINDER DIAMETER	E O-RING	F BACKUP O-RING	G GLAND	H LOADED U CAP	I WIPER
2.0"	2-224	8-224	CS20-GL-01	1250-1125-250B	U-1125
2.5"	2-228	8-228	CS25-GL-01	1870-1125-312B	U-1250
3.0"	2-232	8-232	CS30-GL-01	1870-1125-312B	U-1250
3.5"	2-236	8-236	CS35-GL-01	2500-1500-375B	U-1500
4.0"	2-342	8-342	CS40-GL-01	2500-2250-375B	U-2250
5.0"	2-350	8-350	CS50-GL-01	2500-2250-375B	U-2250

### Piston assemblies

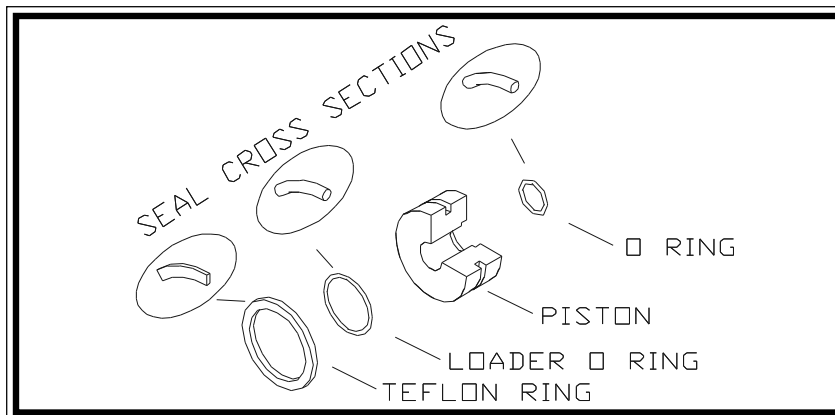

CYLINDER DIAMETER	A TEFLON RING	B LOADER O-RING	C PISTON	D O-RING
2.0"	TFE-S2000	2-129	CS20-PS-01	2-114
2.5"	TFE-S2500	2-137	CS25-PS-01	2-116
3.0"	TFE-S3000	2-145	CS30-PS-01	2-116
3.5"	TFE-S3500	2-151	CS35-PS-01	2-118
4.0"	TFE-S4000	2-153	CS40-PS-01	2-124
5.0"	TFE-S4500	2-157	CS50-PS-01	2-124



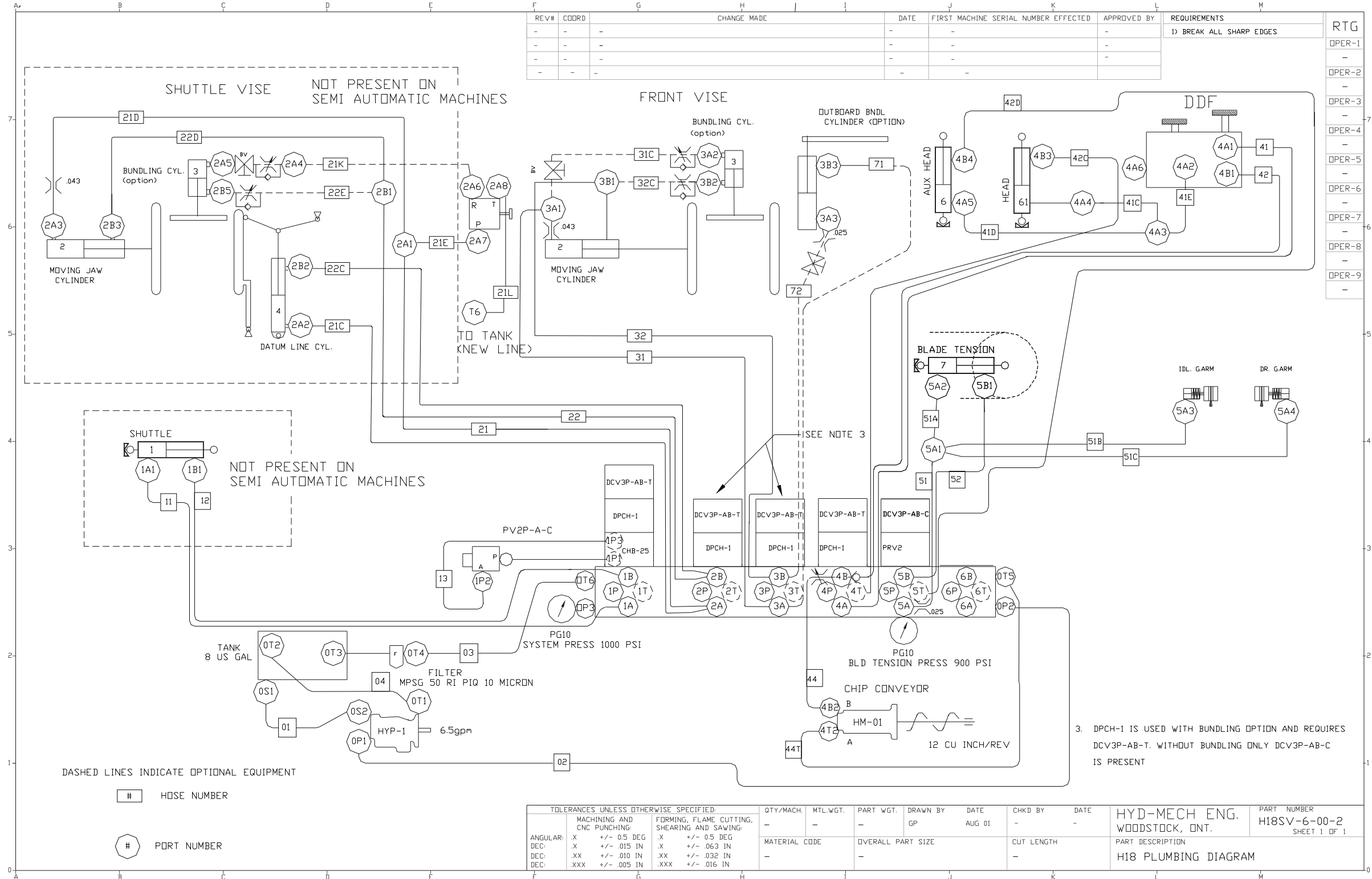

## SECTION 6, MECHANICAL ASSEMBLIES

### H-18 BLADE BRUSH ASSEMBLY

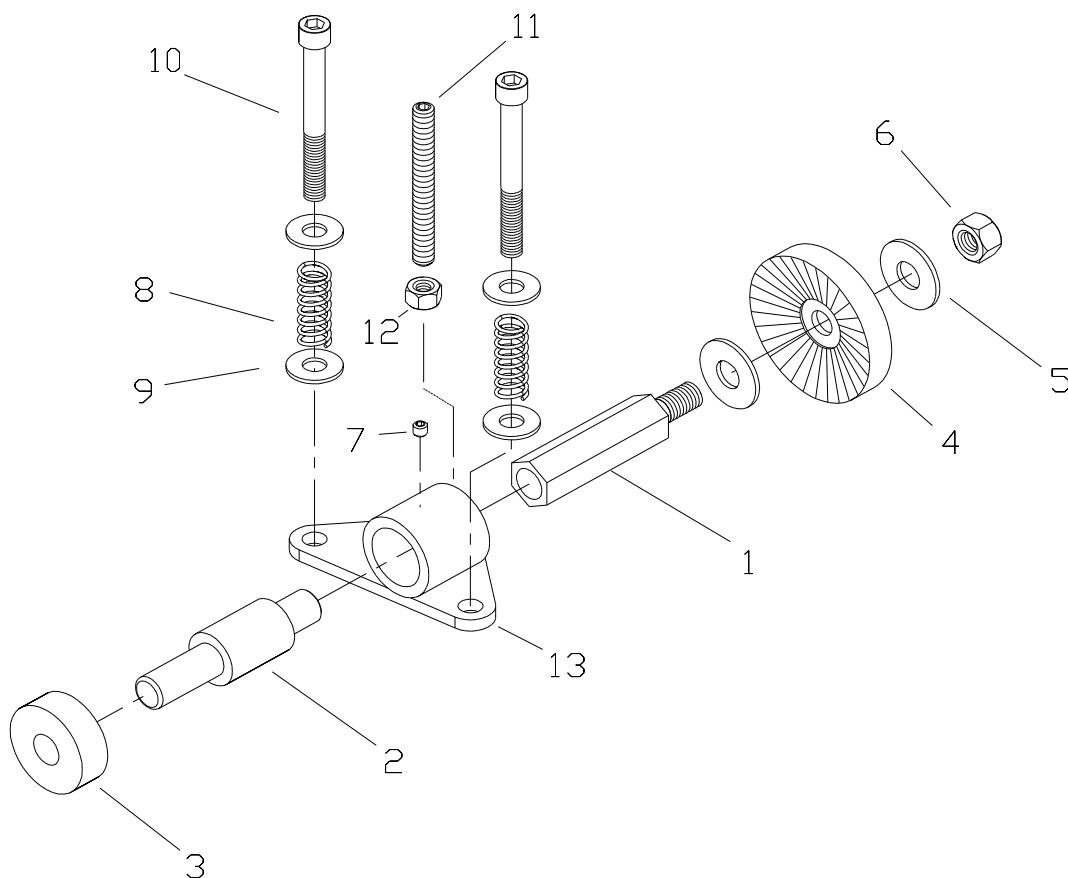

ITEM	QTY	S-22 PART NUMBER	DESCRIPTION
1	1	S22-43-01B	SHAFT EXTENSION
2	1	W6440-4	BEARING
3	1	S20-925-03	POLYURETHANE WHEEL
4	1	5043	3" BLADE BRUSH
5	2	.5FLT	FLAT WASHER
6	1	.5-13HXNUT	HEX NUT
7	1	S1-.25X.25-C	SOCKET SET SCREW, CUP POINT
8	2	TC 13	COMPRESSION SPRING
9	4	.375FLT	FLAT WASHER
10	2	A1-.375X3.5	SOCKET HEAD CAP SCREW
11	1	S1-.375X2.5	SOCKET SET SCREW, FLAT POINT
12	1	.375-16HXNUT	HEX NUT
13	1	S22-431-00A	BEARING PLATE WELDMENT

## H-18 GUIDE ARM ASSEMBLY

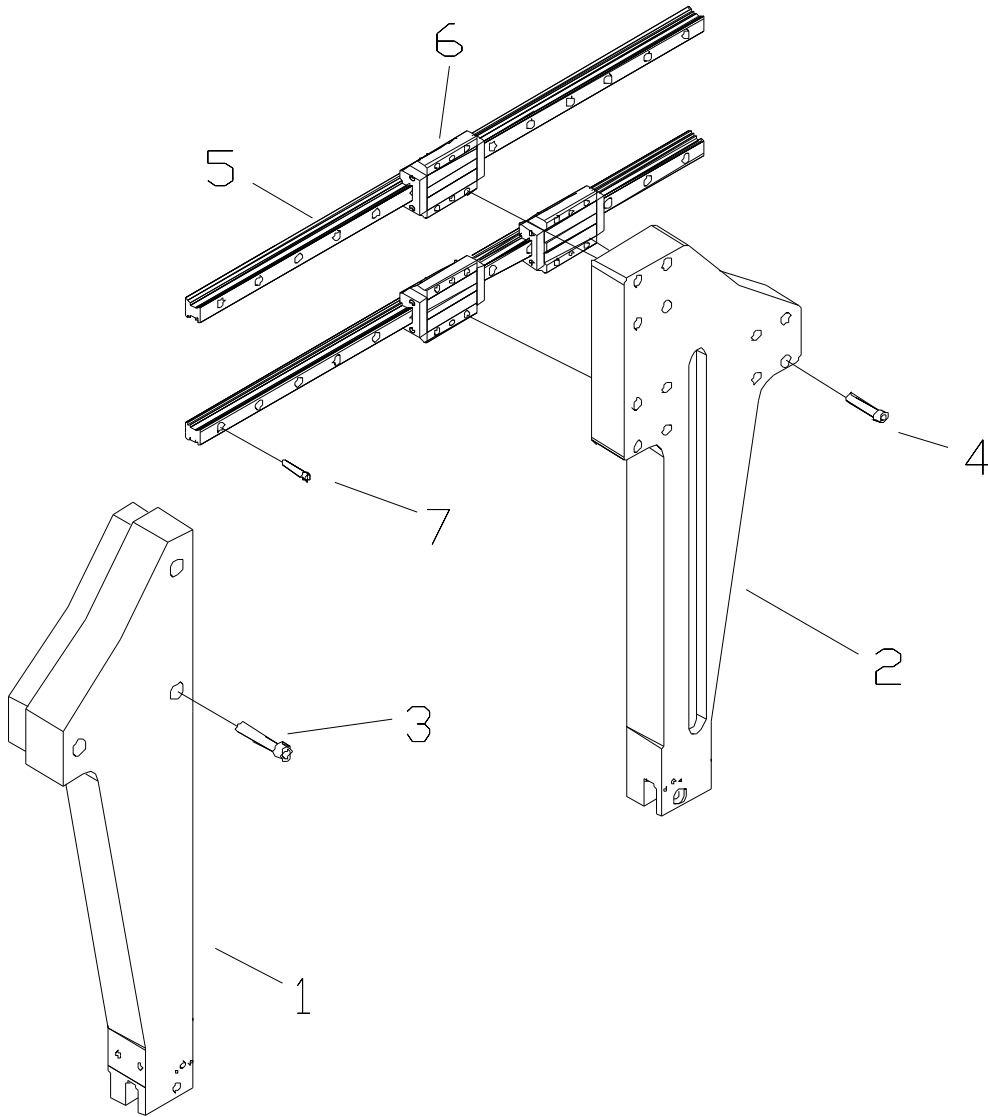

ITEM	QTY	H-18SV PART NUMBER	DESCRIPTION
1	1	H18SV-461-00	FIXED GUIDE ARM
2	1	H18SV-471-01B	MOVABLE GUIDE ARM
3	3	A1-.5x3.5	SOCKET HEAD CAP SCREW
4	12	A3-8x40	SOCKET HEAD CAP SCREW, METRIC
5	2	LGR25R780	LINEAR BEARING RAIL
6	3	LGW25CA	LINEAR BEARING BLOCK
7	24	A1-.25x1.25	SOCKET HEAD CAP SCREW

## HYDRAULIC CARBIDE GUIDE ASSEMBLY

(One assembly on each guide arm.)

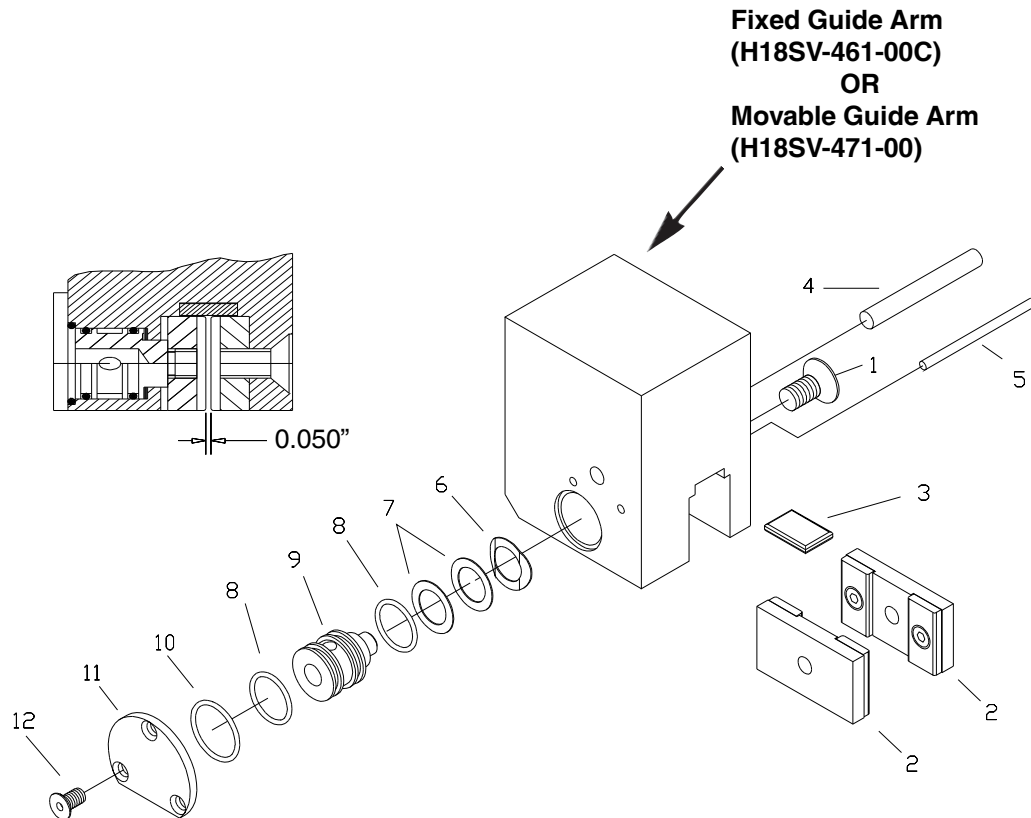

See the following page for set up instructions.

ITEM	QTY	H-18 PART NUMBER	DESCRIPTION
1	1	F1-.312x.5	FLAT SOCKET HEAD CAP SCREW
2	2	CRB-150-22-00A	CARBIDE PLATE
3	1	CRB-TL-770	TOP CARBIDE
4	1	.25x1.25	ROLL PIN
5	2	.156x1.75	ROLL PIN
6	1	W-270	bow WASHER
7	0...4	1059-159....-162	SHIMS (as required)
8	2	016	O RING (chlorophene)(1/16X5/8X3/4)
9	1	H14-47-04B	CARBIDE LOCKING piston
10	1	1/16x7/8x3/4	O RING
11	1	H14-47-05a	COVER, carbide locking cylinder
12	3	A1-.19x.25	SOCKET HEAD CAP SCREW

## ANTIVIBRATION ROLLER ASSEMBLY

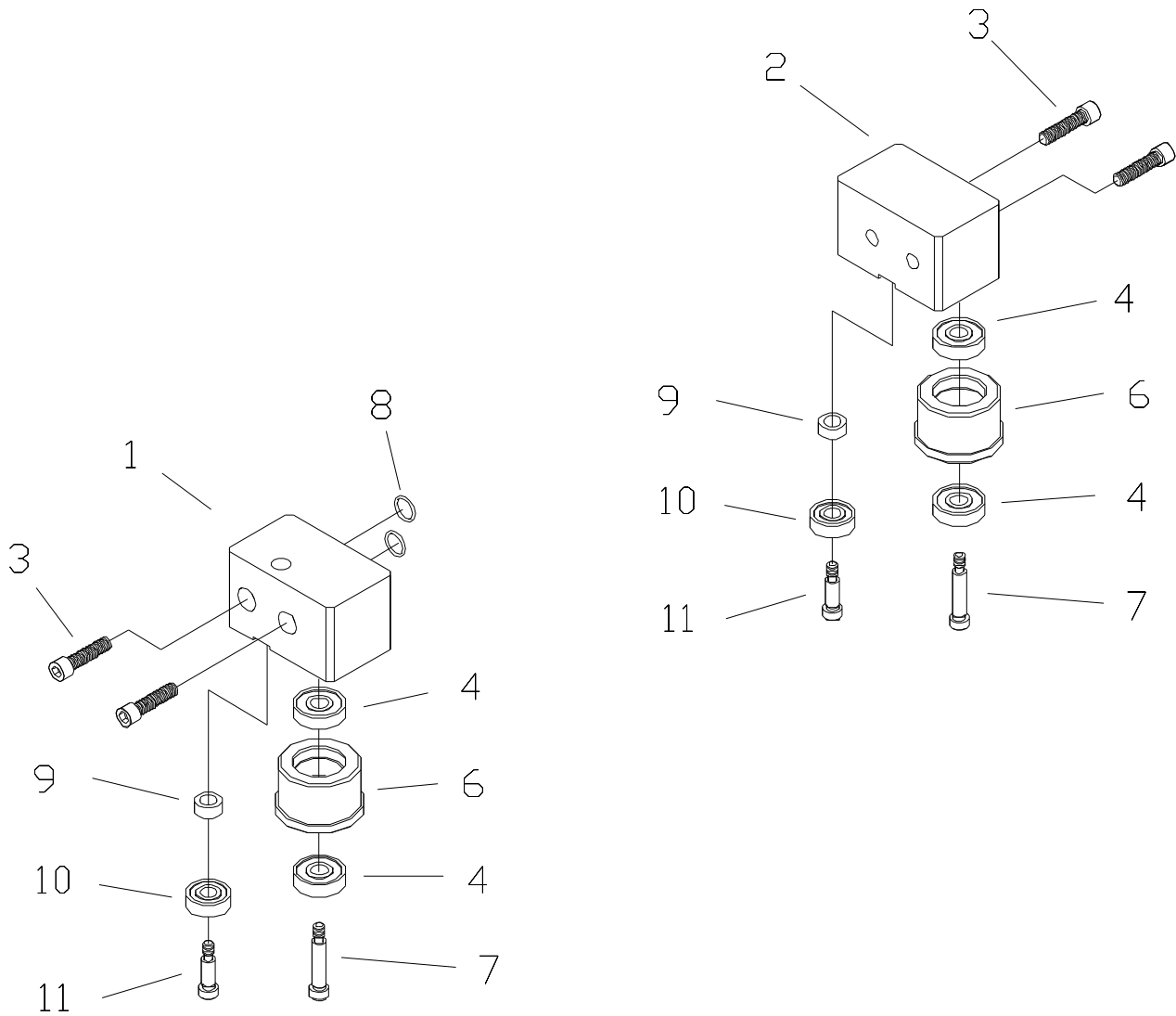

ITEM	QTY	H18-22 PART NUMBER	DESCRIPTION
1	1	AVR-471-01A	BLOCK, IDLER SIDE
2	1	AVR-461A-01	BLOCK, DRIVE SIDE
3	4	A1-.375x2	SOCKET HEAD CAP SCREW
4	6	6200 2RS	BALL BEARING
5	1	AVR-461-03	BACK ROLLER RACE
6	2	AVR-461-02A	FRONT ROLLER RACE
7	3	B3-10x30S	METRIC SOCKET HEAD SHOULDER SCREW
8	2	014	O-RING (.625x1/16)
9	4	AVR-471-02A	BUSHING
10	1	6000 2RS	BALL BEARING
11	1	B3-10x16	METRIC SOCKET HEAD SHOULDER SCREW

## H-18 IDLER WHEEL ASSEMBLY

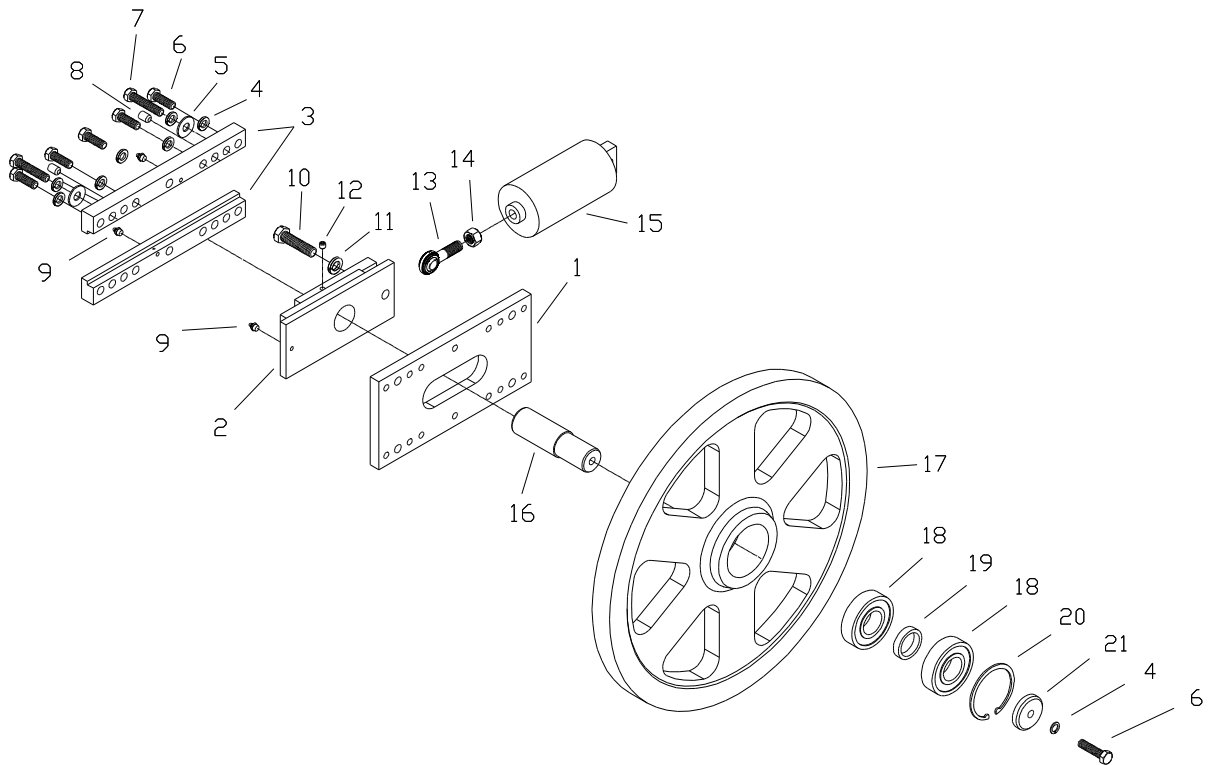

ITEM	QTY	H-18 PART NUMBER	DESCRIPTION
1	1	S25-341-01A	IDLER TRACK BASE PLATE
2	1	S25-3411-00B	IDLER WHEEL CARRIER WELDMENT
3	2	S25-341-02A	IDLER TRACK
4	15	.5LOC	LOCK WASHER
5	4	.5FLT	FLAT WASHER
6	11	B1-.5x1.5	HEX HEAD CAP SCREW
7	4	B1-.5x2.5	HEX HEAD CAP SCREW
8	4	S1-.5x.75C	SOCKET SET SCREW, CUP POINT
9	3	1613-B	STRAIGHT GREASE FITTING
10	1	B1-.625x2.5	HEX HEAD CAP SCREW
11	1	.625LOC	LOCK WASHER
12	1	S1-.375x.375	SOCKET SET SCREW, CUP POINT
13	1	CM10	5/8 NF ROD END
14	1	.625-18HNUT	5/8-18 HEX NUT
15	1	S25-C5-00	TENSION CYLINDER
16	1	H18-43-03	IDLER WHEEL SHAFT
17	1	W22-45-00	IDLER WHEEL
18	2	6310-2RS	BALL BEARING
19	1	H18-45-02	IDLER WHEEL BEARING SPACER
20	1	HO-0433-PA	3/16 INTERNAL RETAINING RING
21	1	WP-1-01	IDLER WHEEL RETAINER

## HYDRAULIC PUMP ASSEMBLY

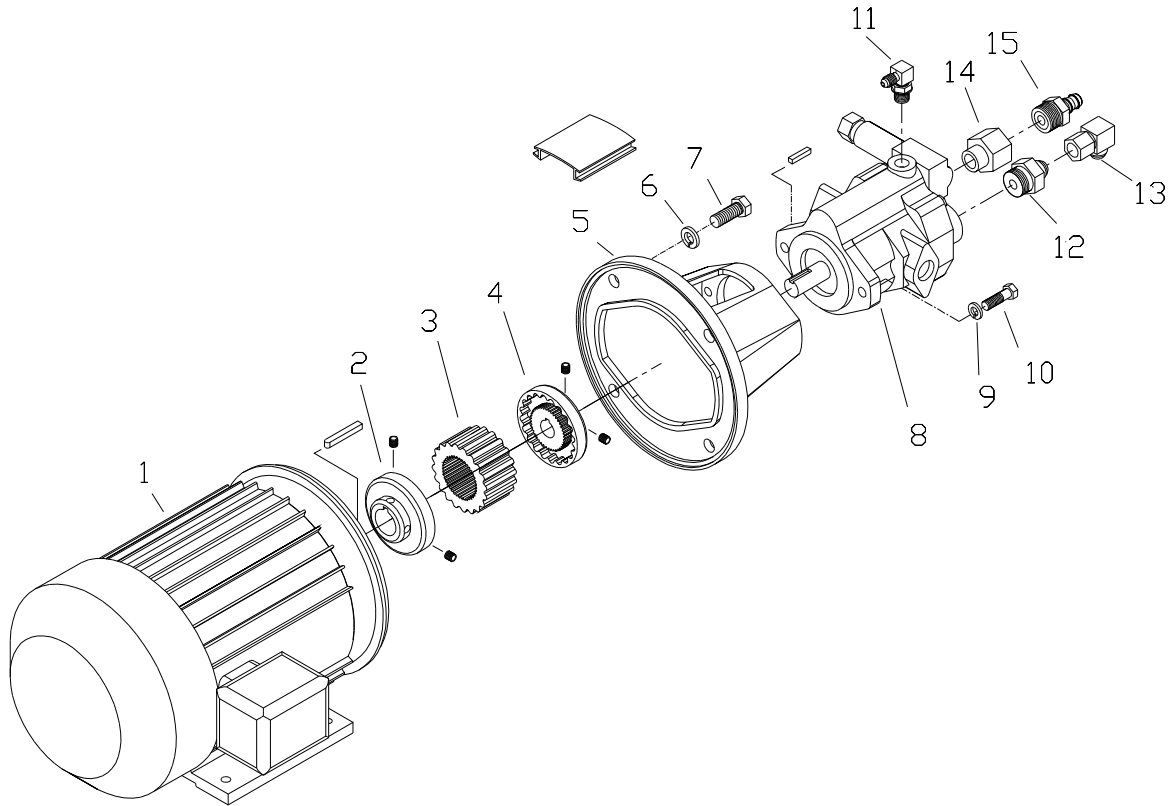

ITEM	QTY	H-18 PART NUMBER	DESCRIPTION
1	1	182TC	3 HP, 1800RPM, SPECIFY VOLTAGE
2	1	5J - 1 1/8	SUREFLEX COUPLING FLANGE
3	1	5JEM	SLEEVE
4	1	5J 3/4	SUREFLEX COUPLING FLANGE
5	1	1960	3 & 5HP BELL HOUSING
6	4	.5LOC	LOCK WASHER
7	4	B1-.5x1.5	HEX HEAD CAP SCREW
8	1	PVQ-13-A2R-SE-15-10-CM7	HYDRAULIC PUMP
9	2	.375LOC	LOCK WASHER
10	2	B1-.375x.75	HEX HEAD CAP SCREW
11	1	2501-6-4	90 deg ELBOW, 9/16NF/MJIC
12	1	0503-12-8	O RING FITTING, 1 1/16"NF/MJIC
13	1	3903-8-8	FITTING, 90 deg SWIVEL, F/MJIC
14	1	0502-12-12	FITTING, 1 1/16"NF/FNPT
15	1	0188-12-12	FITTING, MNPT/HOSE BARB

## HYDRAULIC TANK ASSEMBLY

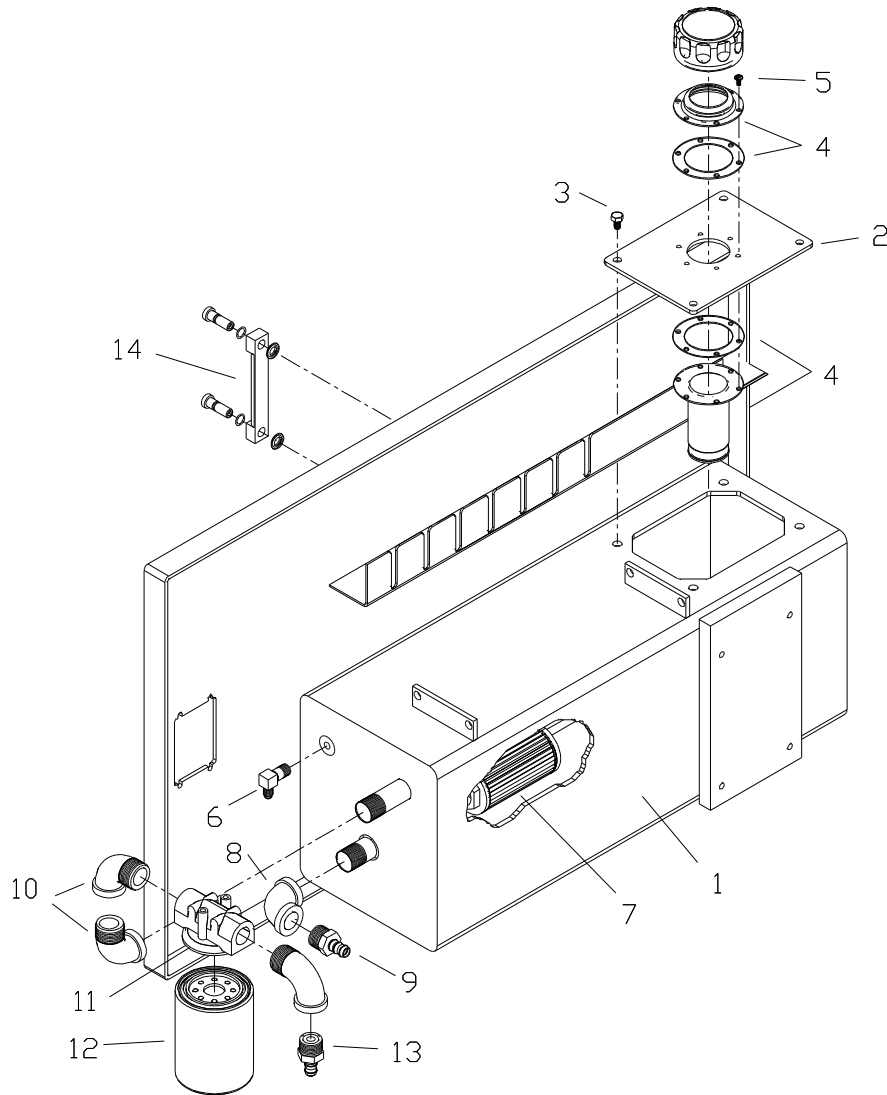

ITEM	QTY	H-18 PART NUMBER	DESCRIPTION
1	1	H16-611-00	POWER PACK WELDMENT
2	1	H16-61-01	OIL TANK LID
3	10	S1-.19x.5	SOCKET HEAD CAP SCREW
4	1	SES-3-40-S-80	FILLER CAP & BREATHER, 50micron
5	6	T1-.19x.5	TRUSS HEAD MACHINE SCREW
6	1	2103-4-4	90 deg ELBOW, MNPT/MJIC
7	1	TFS-100-0-P	SUCTION STRAINER
8	1	MP-100-FE	90 deg ELBOW, FNPT/FNPT
9	1	30182B-12-8	FITTING, FNPT/HOSE BARB
10	3	MP-116-E	90 deg ELBOW, FNPT/MNPT
11	1	SA-F07-25-0	FILTER HEAD
12	1	SF-6520	10 micron RETURN FILTER
13	1	0188-12-12	FITTING, MNPT/HOSE BARB
14	1	SNA-2B	LEVEL & TEMPERATURE GAUGE

## FRONT VISE ASSEMBLY

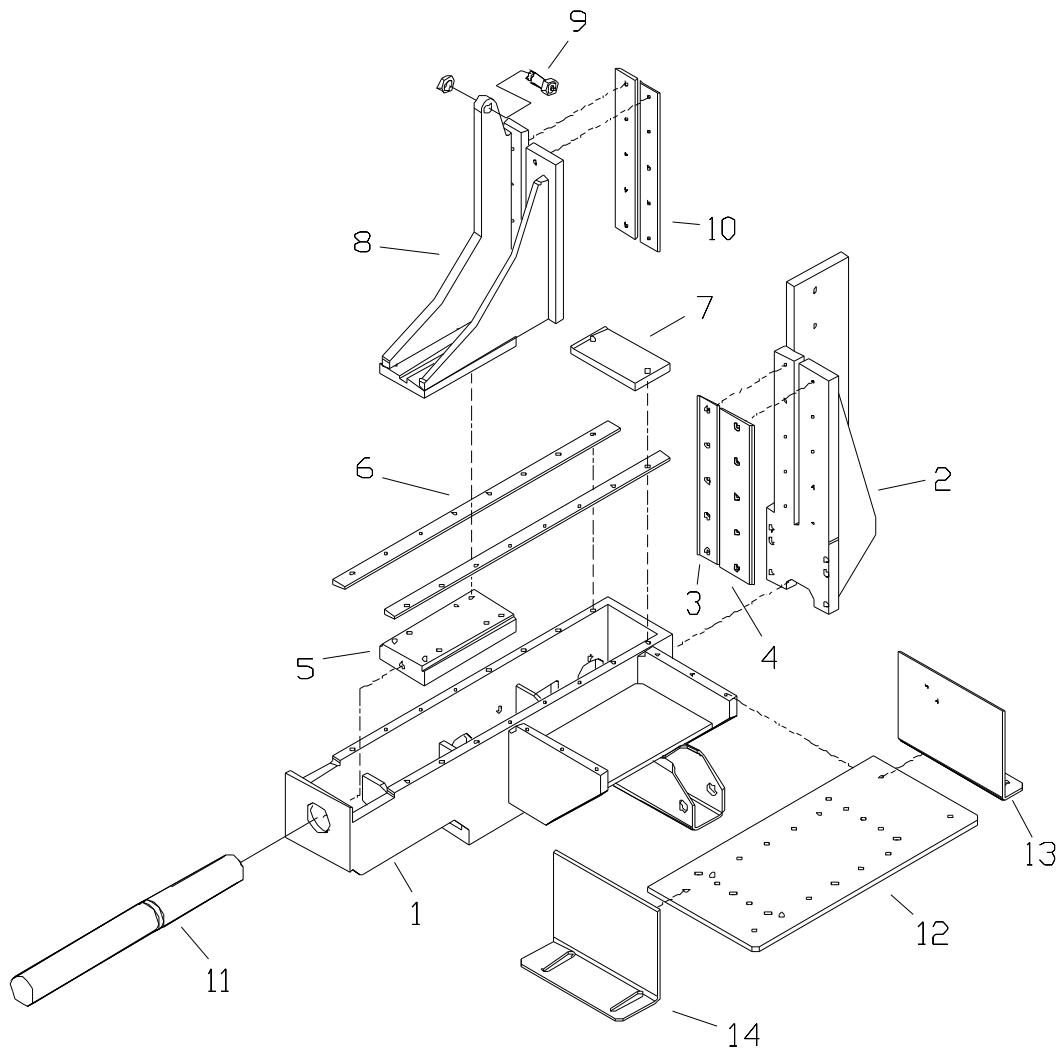

ITEM	QTY	H-18 PART NUMBER	DESCRIPTION
1	1	H18SV-511-00	FRONT VISE FRAME WELDMENT
2	1	H18SV-512-00	FRONT VISE DATUM WELDMENT
3	3	H18SV-5-02	WEAR STRIP
4	1	H18SV-5-03	WEAR STRIP OUT FEED SIDE
5	1	H18SV-5-04	MOVABLE JAW SLIDER
6	2	H18SV-51-01	FRONT VISE WAY
7	3	H18SV-2-06	TABLE INSERT
8	1	H18SV-513-00	FRONT VISE MOVABLE JAW WELDMENT
9	1	H18SV-514-00	TRACK ROLLER ASEMBLY
10	2	H18SV-5-01	WEARSTRIP
11	1	H18SV-C31-00	VISE CYLINDER
12	1	H18SV-2-07	OUT FEED PLATE
13	1	H18SV-2-08	FIXED FENCE
14	1	H18SV-2-09	ADJUSTABLE FENCE

## SHUTTLE VISE ASSEMBLY

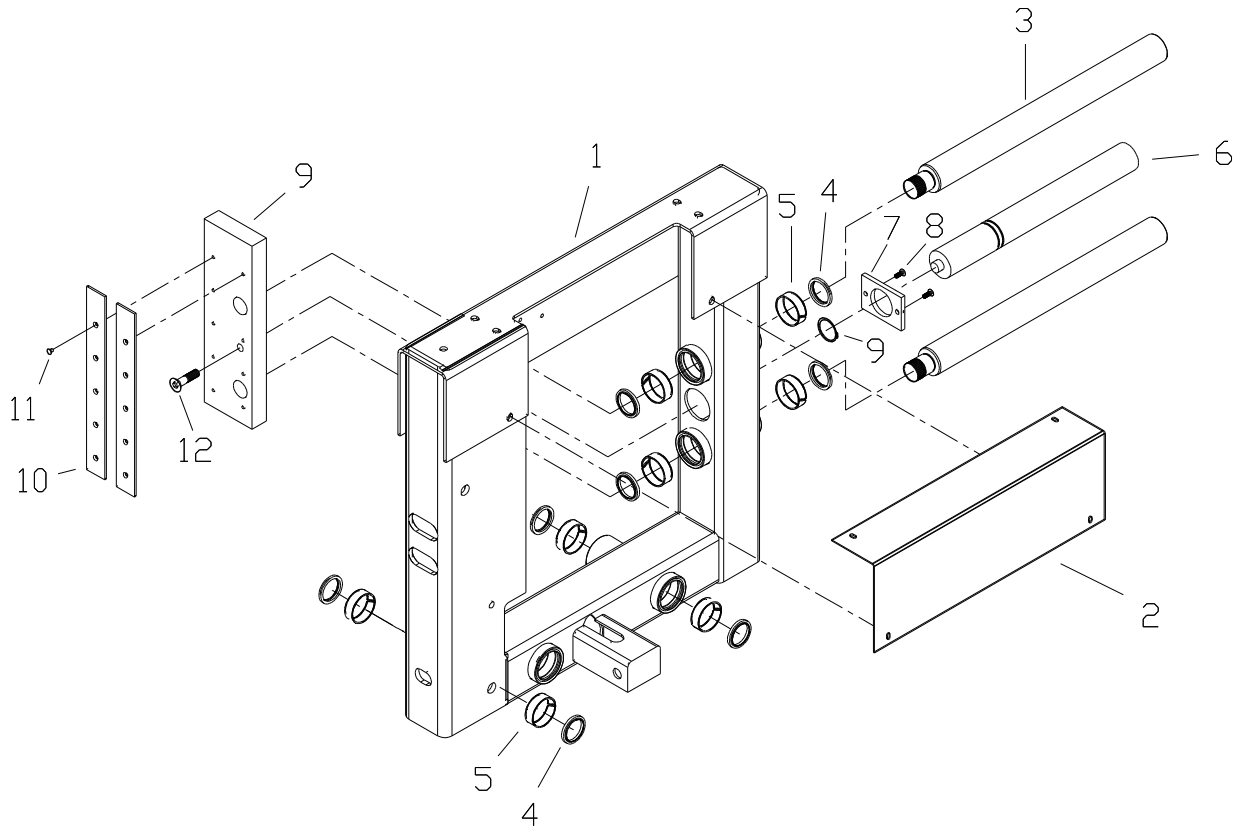

ITEM	QTY	H-18 PART NUMBER	DESCRIPTION
1	1	H22-521-00	FRONT VISE FRAME
2	1	H22-5-01	VISE FRAME COVER
3	2	H22-5-03	MOVABLE JAW SHAFT
4	4	H3000	3" SHAFT WIPER
5	4	9.375x1x.125	WEAR RING (702 STRIP)
6	1	H22-C31-00	VISE CYLINDER
7	1	H22-5-05	CYLINDER MOUNTING PLATE
8	2	F1-.5x1	FLAT SOCKET HEAD CAP SCREW
9	1	SH-0287-PA	2 7/8 EXTERNAL RETAINING RING
10	1	H18-5-04	MOVABLE JAW PLATE
11	2	H18-5-02	WEAR STRIP
12	10	F1-.312x.5	FLAT SOCKET HEAD CAP SCREW
13	1	F1-.75x2	FLAT SOCKET HEAD CAP SCREW

## SHUTTLE VISE DATUM LINE JAW ASSEMBLY

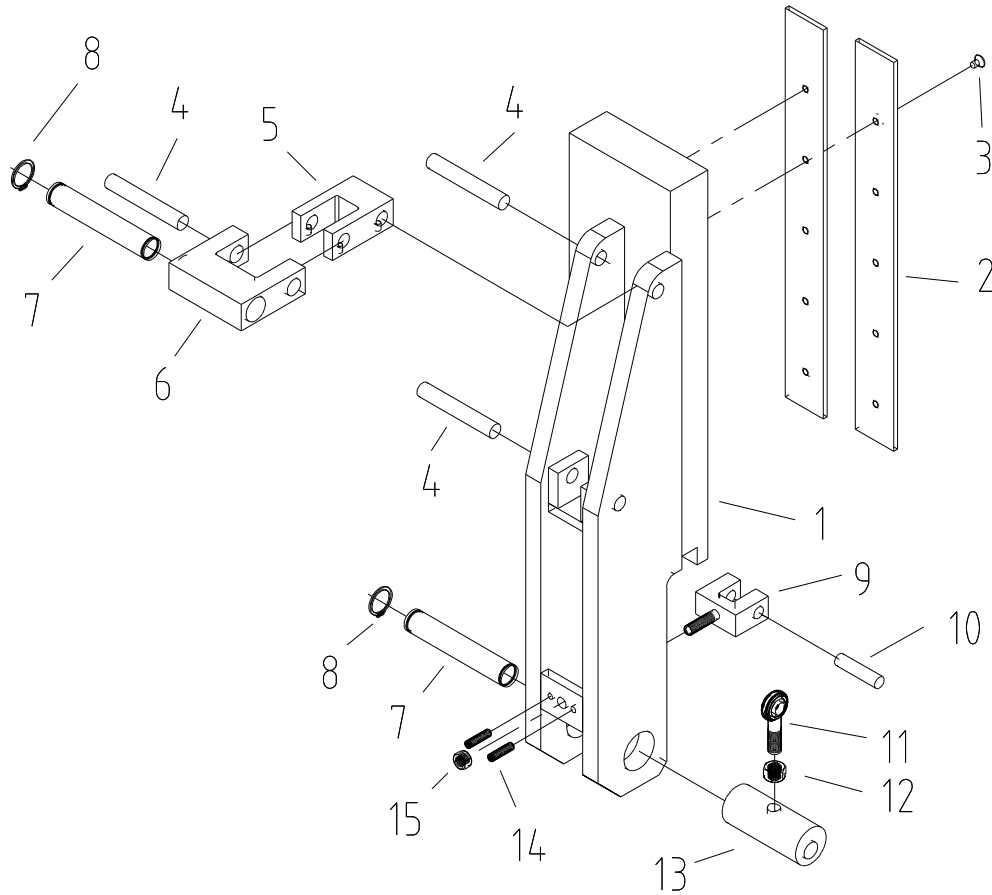

ITEM	QTY	H-18 PART NUMBER	DESCRIPTION
1	1	H18-522-00A	DATUM LINE JAW
2	2	H18-5-02	WEAR STRIP
3	10	F1-.312x.75	FLAT SOCKET HEAD CAP SCREW
4	3	H14-5A-10	SMALL JAW MOUNTING PIN
5	1	H14-5A-12	SMALL DATUM JAW LINK
6	1	H14-5A-11	LARGE DATUM JAW LINK
7	2	H14-5-15	LARGE JAW MOUNTING PIN
8	4	SH-0125-PA	1 1/8 EXTERNAL RETAINING RING
9	1	H14-523-00	YOKE WELDMENT
10	1	H14-5-14	PIN-YOKE ASSEMBLY
11	1	CM-10	1/2" ROD END
12	1	.625NFHXNUT	HEX NUT
13	1	H14-5-13	ECCENTRIC SHAFT
14	2	S1-.375x2	SOCKET SET SCREW
15	1	.375HXNUT	HEX NUT

## CHIP AUGER ASSEMBLY

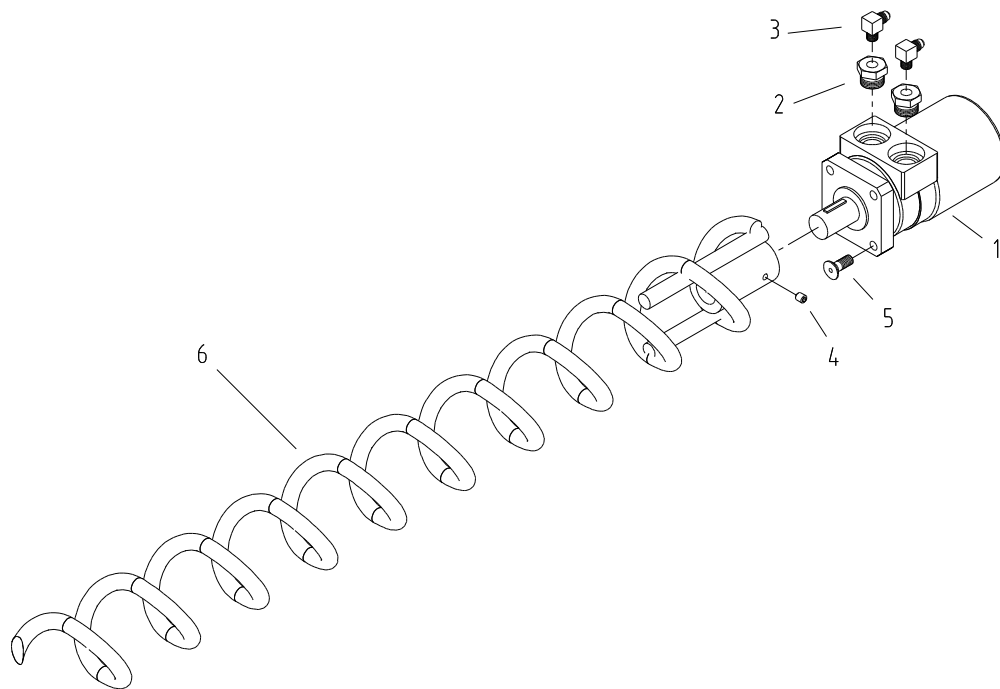

ITEM	QTY	H-18 PART NUMBER	DESCRIPTION
1	1	MG.12.09.10	HYDRAULIC MOTOR
2	2	2503-6-4	O RING ADAPTOR, M STRT/FNPT
3	2	2103-4-4	90 deg ELBOW, MNPT/MJIC
4	1	S1-.312x.25C	SOCKET SET SCREW, CUP POINT
5	4	F1-.375x1	FLAT SOCKET HEAD CAP SCREW
6	1	H18-12-00	AUGER WELDMENT

## H-18 DRIVE ASSEMBLY

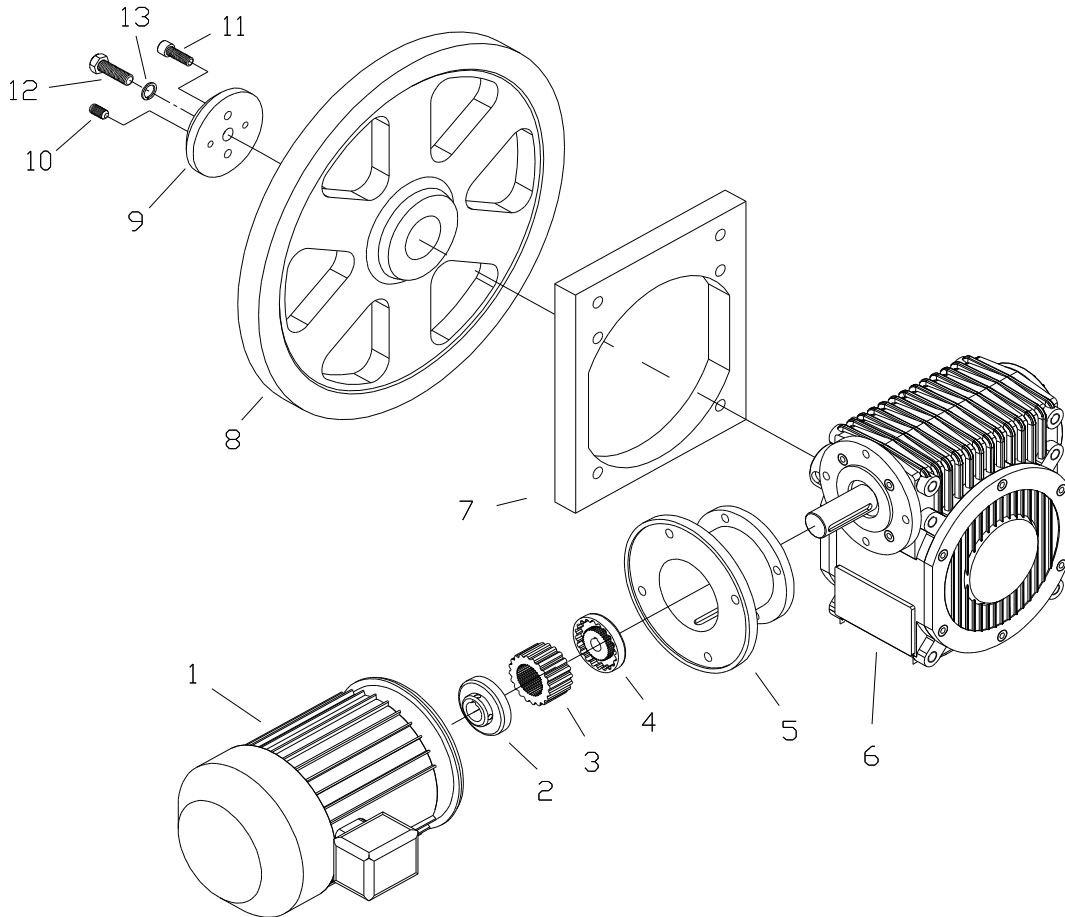

ITEM	QTY	H-18 PART NUMBER	DESCRIPTION
1	1	215TC	10HP, 1800RPM, SPECIFY VOLTAGE
2	1	6Sx1 3/8	COUPLING FLANGE
3	1	6JE	COUPLING SLEEVE
4	1	6Sx38mm	COUPLING FLANGE
5	1	H18-411-00	GEAR BOX CONNECTOR
6	1	HM5B	GEAR BOX 53:1
7	1	H18-4-01	GEAR BOX MOUNTING PLATE
8	1	S25-3-07A	DRIVE WHEEL
9	1	H18-4-02	PUSH PULL DRIVE WHEEL CAP
10	2	S2-.5x1F	SOCKET SET SCREW, FLAT POINT, NF
11	2	A1-.5x1.5	SOCKET HEAD CAP SCREW
12	1	B3-20x60	METRIC HEX HEAD CAP SCREW
13	1	M20LOC	METRIC LOCK WASHER

## SECTION 7, OPTIONS

### H-18 & H-22 BUNDLING ASSEMBLY

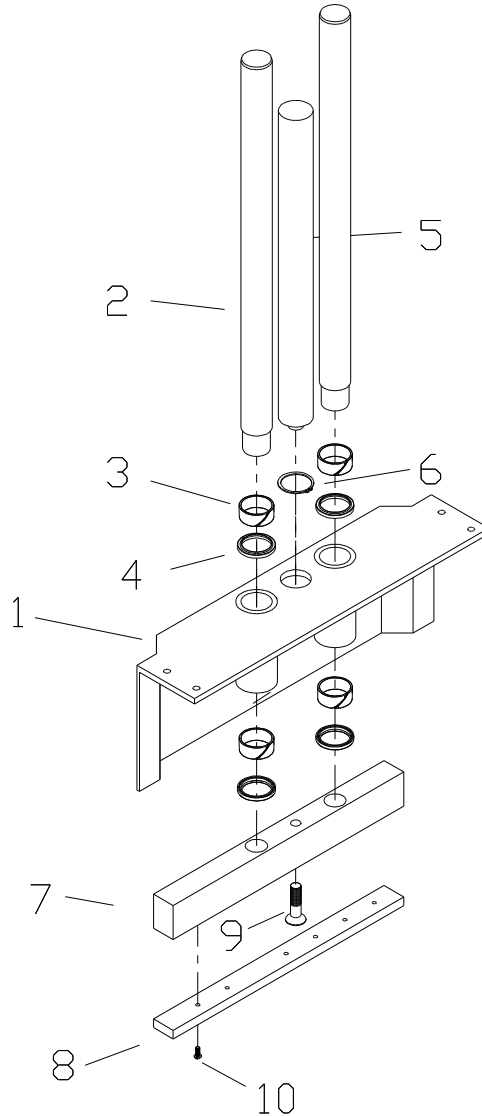

ITEM	QTY	H-22 PART NUMBER	DESCRIPTION
1	1	H22-531A-00	BUNDLING BRACKET WELDMENT
2	2	H22-532-02	BUNDLING SHAFT
3	4	7.26x1x.125	WEAR RING (702 STRIP)
4	4	H2250	2 1/4 SHAFT WIPER
5	1	H22-C23-00	BUNDLING CYLINDER
6	1	SH-0237-PA	2 3/8 EXTERNAL RETAINING RING
7	1	H22-532A-01	BUNDLING CLAMP
8	1	H22-532A-03	WEAR STRIP
9	1	F1-.75x2.5	FLAT SOCKET HEAD CAP SCREW
10	6	A1-.312x.75	SOCKET HEAD CAP SCREW

# H-18 & H-22 OUTBOARD BUNDLING ASSEMBLY

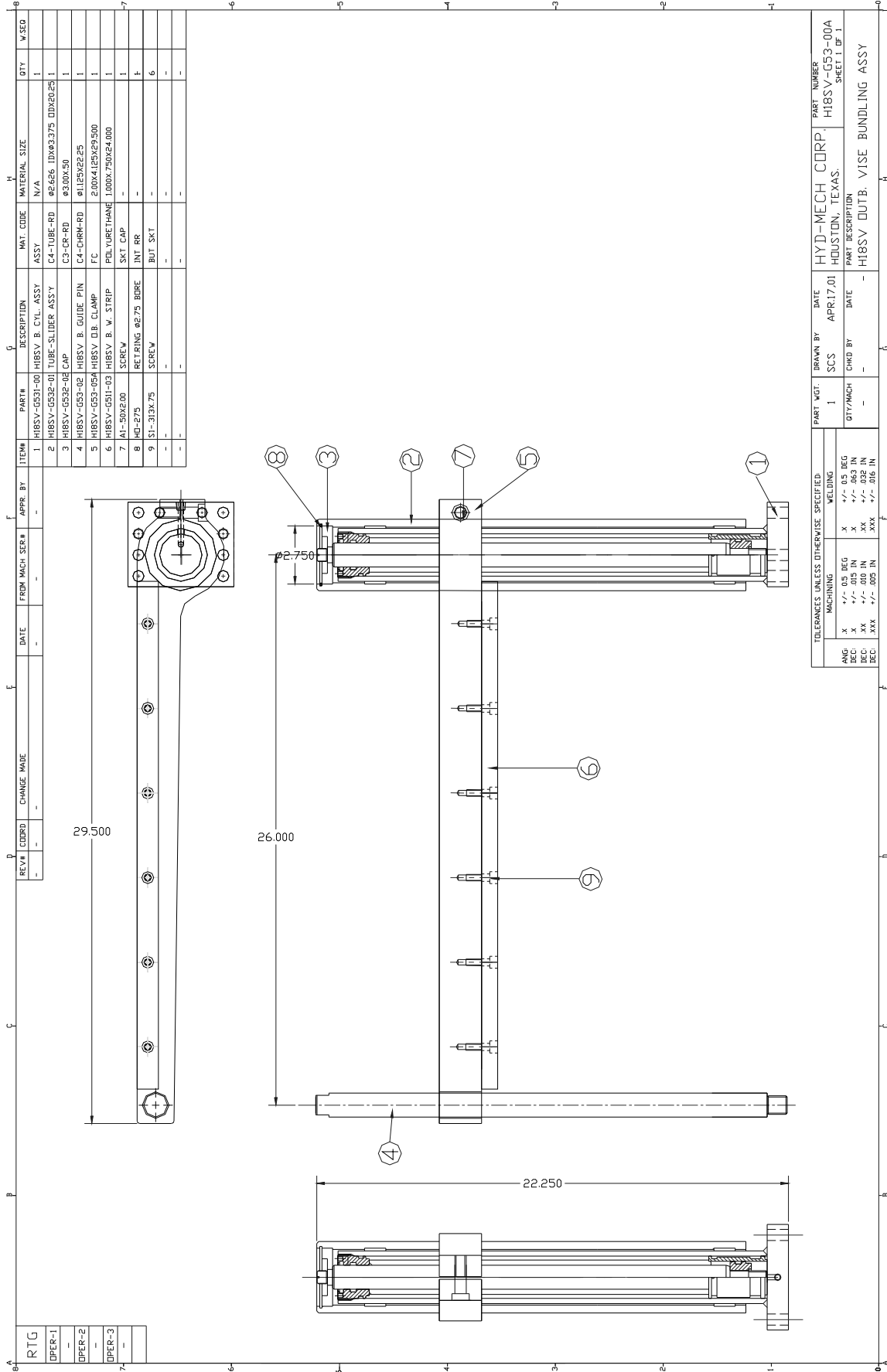

---

## **SECTION 8, SPECIFICATIONS**

### **MODEL H-18**

### **DIMENSIONS**

Capacity	Round: 18" Diameter Square: 18" x 18" (Bundling to full capacity optional)
Blade	Length: 19'2" Width: 1 1/2", 1 1/4" (Optional) Thickness: .050" (.042", 1 1/4 Blade)
Blade Speed	50-350 SFM
Blade Tension	Hydraulic
Blade Guides	Carbide
Blade Wheel Diameter	22"
Motors	Blade Drive: 10 H.P. Hydraulic Drive: 3 H.P.
Pumps	Hydraulic Pump: (Pressure Compensated) Constant pressure variable flow: (6 1/2 G.P.M) Coolant Pump: 3 1/2 G.P.M. (150W)
Hydraulic Tank	9 U.S. Gallons
Hydraulic System Pressure	1000 psi
Vise Control	Hydraulic
Shuttle Stroke	0-34" Single stroke multi-indexing standard
Table Height	31"
Control Panel	Waist Height
Machine Weight	8500 LBS
Maximum Work Load	10000 LBS
Overall Dimensions	127" Wide 88" Long 92.5" High

# H-18 LAYOUT

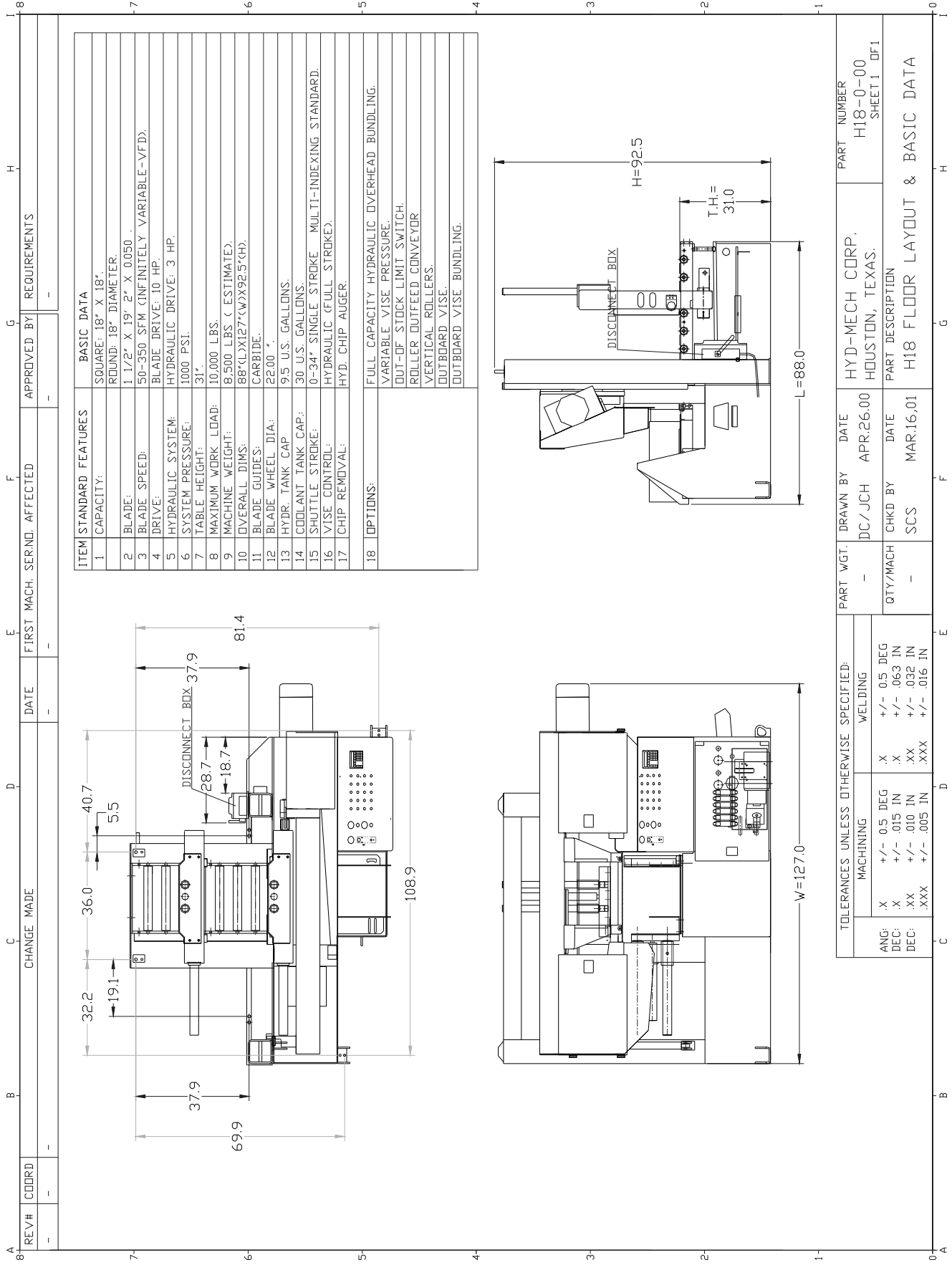

TOLERANCES UNLESS OTHERWISE SPECIFIED:		PART WGT.		DRAWN BY		DATE		PART NUMBER	
MACHINING		-		DC/JCH		APR.26.00		HYD-MECH CORP.	
ANG:	X +/- 0.5 DEG	QTY/MACH	-	CHKD BY	SCS	DATE	MAR.16.01	HOUSTON, TEXAS.	
DEC:	X +/- .015 IN							H18-0-00	
DEC:	XX +/- .010 IN							SHEET 1 OF 1	
DEC:	XXX +/- .005 IN							H18 FLOOR LAYOUT & BASIC DATA	
	XXX +/- .016 IN								

---

## **SECTION 9, WARRANTY**

Hyd-Mech Group warrants each new H-18/22 bandsaw to be free from failure resulting from defective material and workmanship under proper use and service for a period of one year following the date of shipment to the user. Hyd-Mech's sole obligation under this warranty is limited to the repair or replacement without charge, at Hyd-Mech's factory, warehouse, or approved repair shop, of any part or parts which Hyd-Mech's inspection shall disclose to be defective. Return freight must be prepaid by the user.

This warranty, in its entirety, does not cover maintenance items, including but not limited to lubricating grease and oils, filters, V-belts, saw blades, etc., nor any items herein which show signs of neglect, overloading, abuse, accident, inadequate maintenance, or unauthorized altering.

MOTOR, GEARBOX, PUMP, ELECTRIC COMPONENTS, VALVES, HOSES, FITTINGS, and any other items used in the manufacture of the H-18/22, but not originally manufactured by Hyd-Mech are subject to the original manufacturer's warranty. Hyd-Mech will provide such assistance and information as is necessary and available to facilitate the user's claim to such other manufacturer.

Liability or obligation on the part of Hyd-Mech for damages, whether general, special or for negligence and expressly including any incidental and consequential damages is hereby disclaimed. Hyd-Mech's obligation to repair or replace shall be the limit of its liability under this warranty and the sole and exclusive right and remedy of the user.

THIS WARRANTY IS EXPRESSLY IN LIEU OF ALL OTHER WARRANTIES, EXPRESSED OR IMPLIED, WRITTEN OR ORAL, INCLUDING WITHOUT LIMITATION ANY IMPLIED WARRANTIES OF MERCHANTABILITY OR FITNESS FOR A PARTICULAR PURPOSE.

This warranty may not be changed, altered, or modified in any way except in writing by Hyd-Mech Group.

HYD-MECH GROUP  
1079 Parkinson Road  
P.O. BOX 1030  
Woodstock, Ontario  
N4S 8A4

Phone: (519) 539-6341  
Fax: (519) 539-5126  
Toll Free (877) 237-0914  
e-mail: [info@hydmech.com](mailto:info@hydmech.com)

# MITSUBISHI PLC 100 (FX2n48MR) PARAMETERS

(refer to "Calibration Procedures" in Sec 3, for proper usage of paramters)

Interface, E200

2100 software, Version \_\_\_\_\_

SPEED CONSTANT	WHEEL TRGETS	HGT CLB (PRESS "ENTER")
ACTUAL HGT	HGT CONSTANT	LTH CLB (PRESS "ENTER")
ACTUAL LTH	LTH CONSTANT	ACCEL DIST
DECEL DIST	MIN FST DIST	TARGET WINDOW
FVO DWELL	SVO DWELL	CLOSE TIME
FEED RATE	ACTUAL POSITION	HOLD SHT HOME
YES / NO	YES / NO	YES / NO
BRKN PROX	MIN BLD SPEED	SPD PROX DELAY
YES / NO		
POWER DWN TIMER	BLADE CLEAR	TRIM CUT
	YES / NO	YES / NO
OUT OF STOCK (option)	COOLANT	QUEUE
YES / NO	BLD / BLD+DWN	SINGLE / REPEAT

DATE: \_\_\_ / \_\_\_ / \_\_\_  
MM DD YY

SER# \_\_\_\_\_

VOLTAGE: \_\_\_\_\_