



# DRYING SYSTEMS

by Makor



PANEL

Drying 

WOOD DIVISION



# ULTRADRY

## New UV Oven

ULTRADRY drying system for the instantaneous polymerization of the UV paints on flat and shaped panels, edges included. Its modularity allows different configurations for any kind of paints and production speed.



### PLUS

- ✓ Modular system, from one to three lamps, bottom lamp version is available
- ✓ Ergonomic, touch screen control panel
- ✓ New shape of the shields for higher efficiency
- ✓ Lamps powered by electronic feeders, high energy saving, stand-by at 15%
- ✓ Belt transport system
- ✓ Ultradry version to dry flat parts and edges (perfect for spraying lines)
- ✓ ULTRADRY FLAT version only for flat surface (ideal for roller and curtain coaters lines)
- ✓ Lamps with dichroic glass to get lower temperature on the piece (OPT)



Link to on-line  
version

HIGH EFFICIENCY AND HIGH PEAK ENERGY

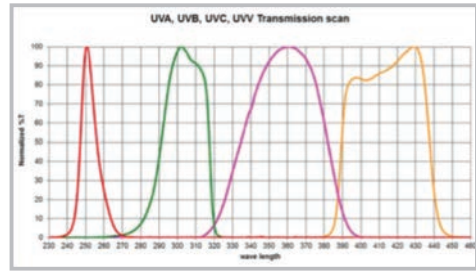
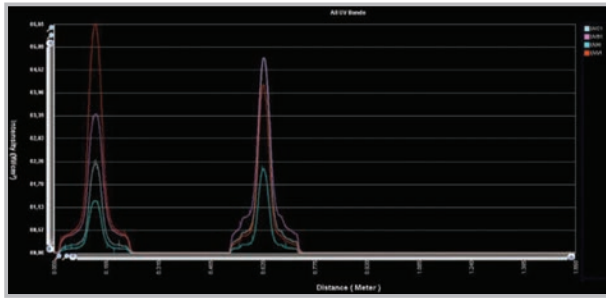

**Broad Band**  
 UVA (320-390 nm) / UVB (280-320 nm)  
 UVC (250-260 nm) / UVV (395-445 nm)

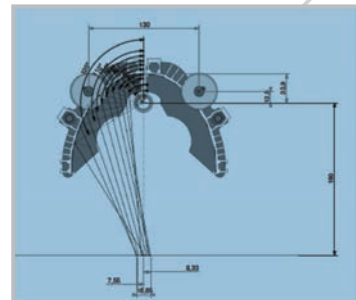
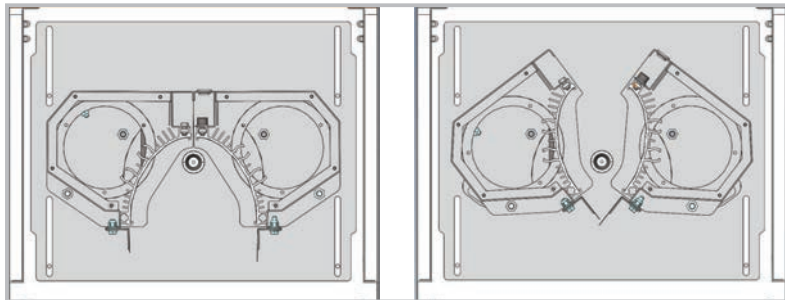

Lamp unit with shutter for stand-by management.  
High cooling efficiency

High performance,  
parabolic geometry with  
optimized focused beams

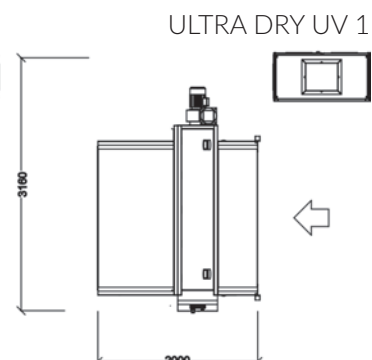
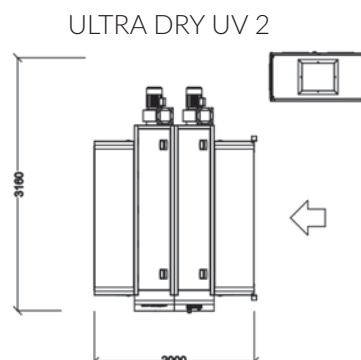
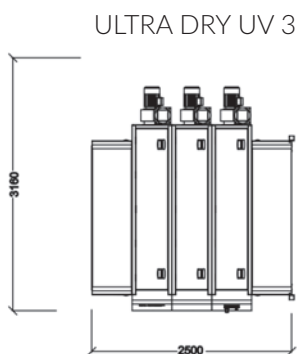
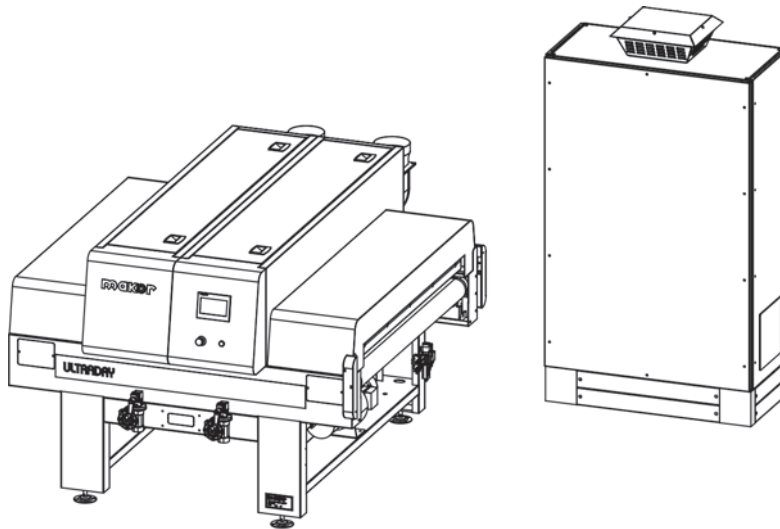



# FAST DRY

## Linear Tunnel

Modular design, it houses different thermal elements used in the drying and drying processes.  
Machine of great flexibility ideal for drying or drying painted products.  
The transport takes place thanks to a series of idle powdered-painted rollers pulled by a pair of parallel chains, or by means of a continuous conveyor belt



### CTA - AIR TREATING UNIT FOR DRY AND WATER FILTERING (optional)

Air treatment unit, Air F7 filtration, heating with hot water coil, adiabatic humidification, cooling. To guarantee optimal spraying, air cleaning, temperature and humidity conditions.

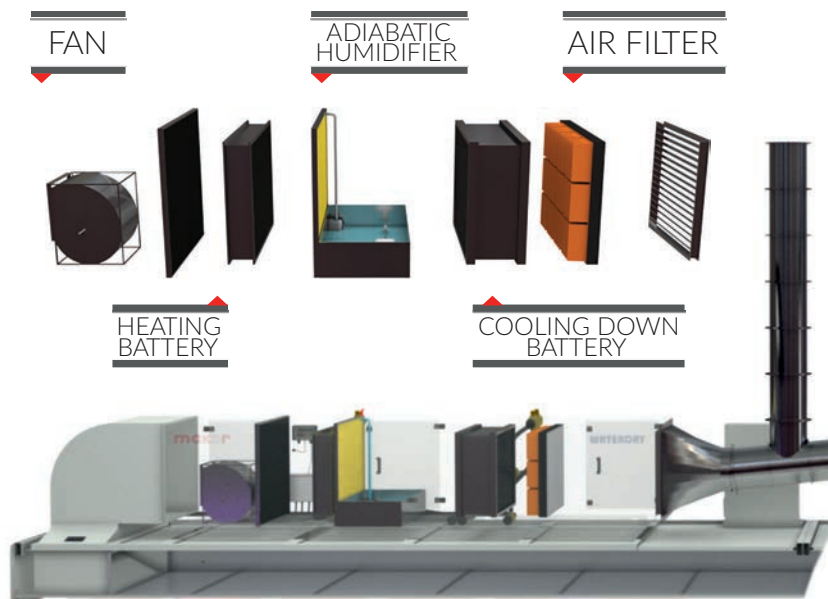

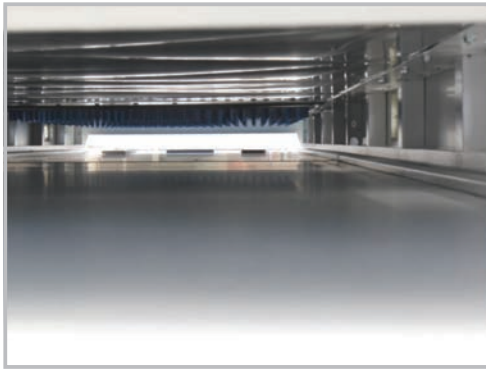

Belt transport

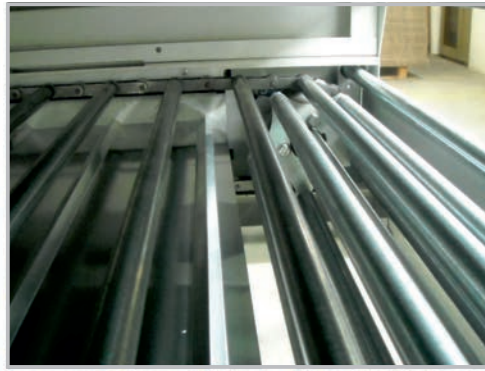

Roller transport



Wind-Jet hood



IR/NIR lamps hood



TL lamps hood



FAST DRY - Possible versions									
Length mt	4	6	8	10	12	14	16	18	20
Laminar hood	x	x	x	x	x	x	x	x	x
Wind-Jet hood	x	x	x	x	x	x	x	x	x
IR/NIR lamps	x	x	x	x	x	x	x	x	x
Roller transport	x	x	x	x	x	x	x	x	x
Belt transport	x	x	x	x	x	x	x	x	x
CTA	x	x	x	x	x	x	x	x	x
Chiller	x	x	x	x	x	x	x	x	x

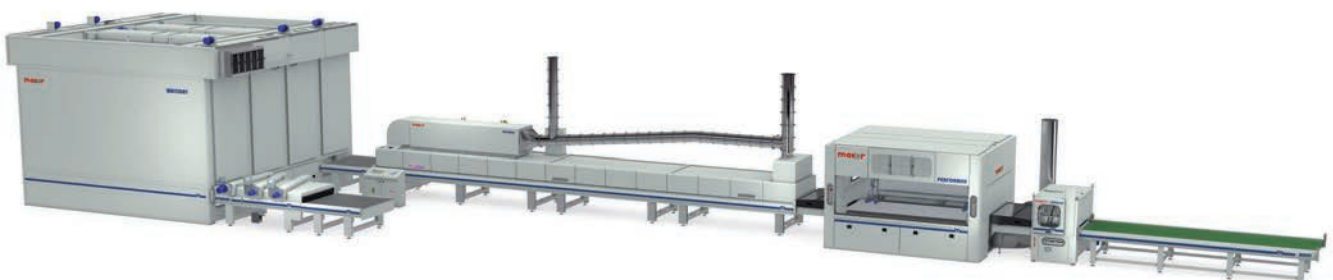



# MULTILEVEL

## Compact Drying Oven

Drying oven perfect for small or fully automatic lines. The modern technological systems added to the ventilation device allow drying in short times fast reticulation paints or flashing off paints at UV hardness or curing glues to subsequently veneer panels. Compact structure, with 6 overlapped belted-trays, housed in a highly insulated chamber, the machine can work in very reduced spaces. Euro 4 Filtering system.

No contact with external agents. Adjustable temperature. Air heated through a hot water battery.



Multilevel possible versions					
	Belt length	Number of stages	Maximum thickness 6 belts	Maximum thickness 5 belts	Maximum overall dimensions mm.
Multilevel 3600	3600	6-5	60 mm	90mm	5310x3075x3175 H.
Multilevel 5500	5500	6-5	60mm	90mm	7210x3075x3175 H.
Multilevel 7000	7000	6-5	60mm	90mm	8710x3075x3175 H.
On the upper belt without covering Max 100mm Special Version					

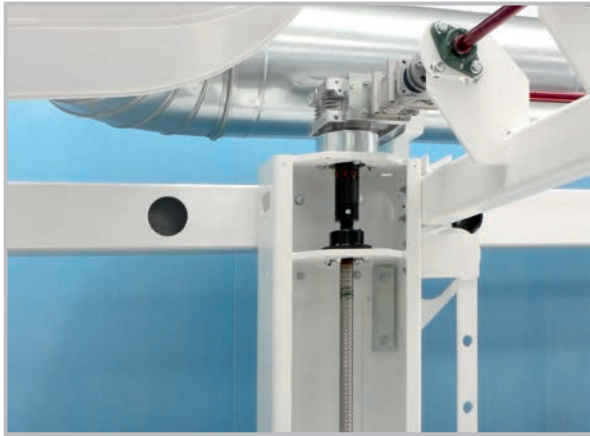

**LEVEL MOTORIZATION**

It is realized with precision mechanic, synchronized motors and ball recirculation screws. Maximum precision, reliable over time

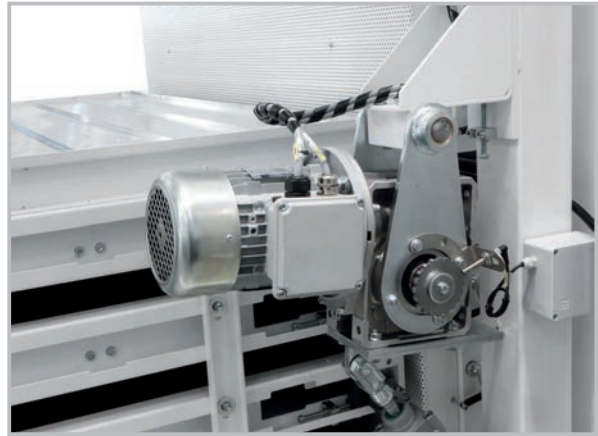

**MOTORIZATION AND AIR**

Belt motorization and air distribution plenum detail



High quality construction. Functional design.

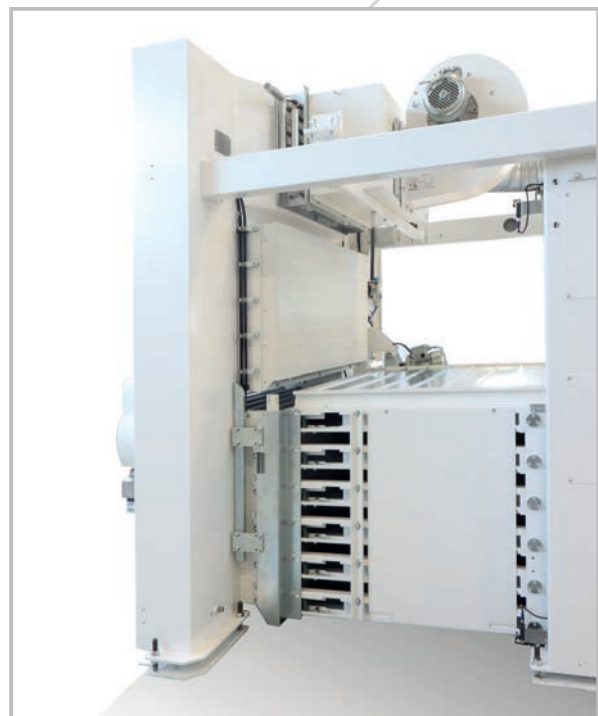

Laminar ventilation hood with activation shutter

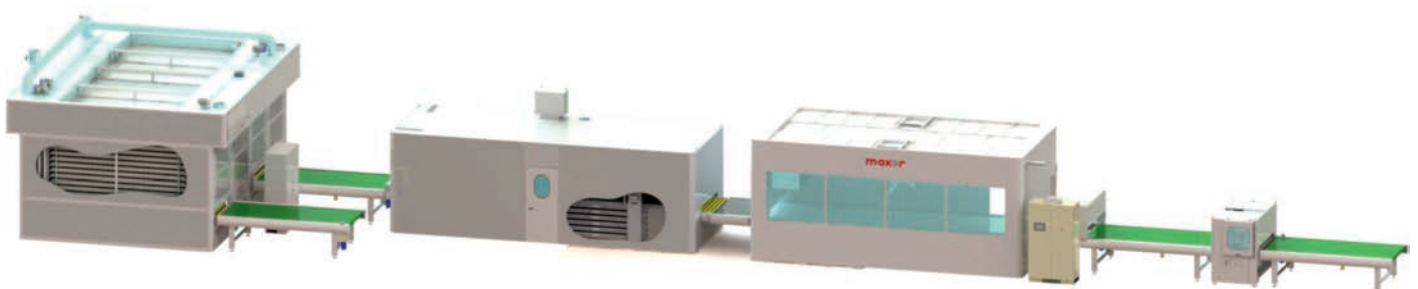



# MULTIDRY

## Drying Oven

Hot air drying oven, 2-3-4-6 stages version.  
 With medium-long dwelling drying time.  
 Oven version with trays and belts



2 STAGES

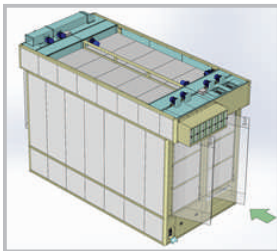

3 STAGES

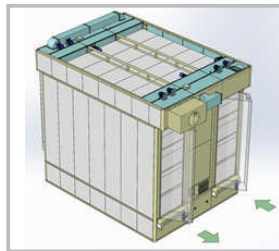

4 STAGES

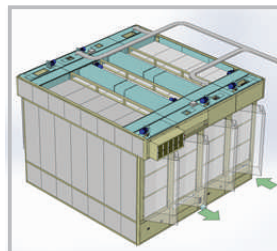

6 STAGES

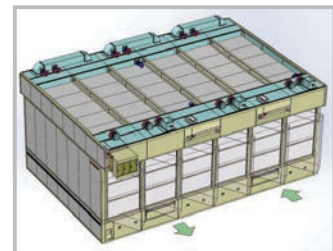

MULTIDRY - Possible versions			
	2 stages	3 stages	4 stages
trays number for piece thickness max 40-70 mm	30-48	31-49	54-90
trays number for piece thickness max 60-90 mm	20-40	21-41	34-74
belts number for piece thickness max 50-60	20-40	21-41	34-74
trays version	x	x	x
belts version	x	x	x
trays length 3600	x	x	x
trays length 5500	x	x	x
belts length 5500	x	x	x
belts length 7000	x	x	x
Versions for special thicknesses up to 300 mm	x	x	x

Operating scheme of 4 stages oven.

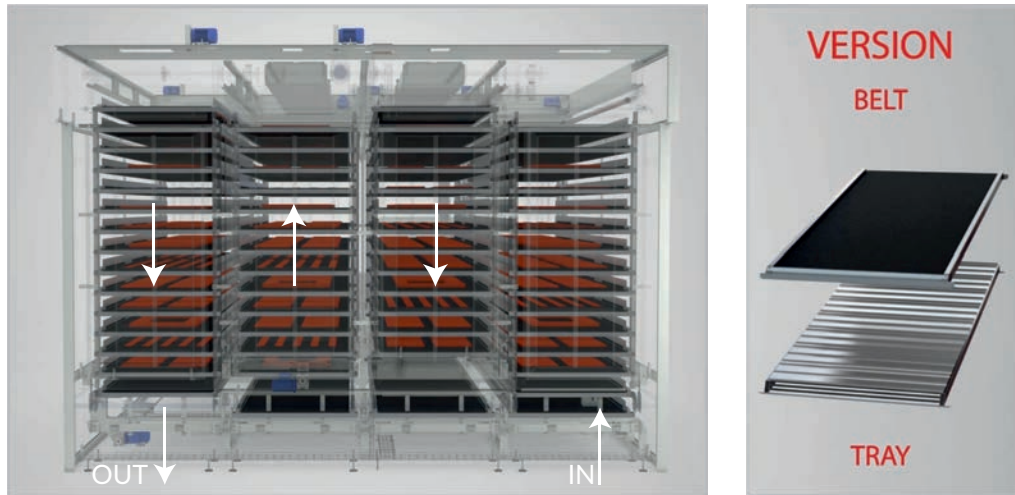

Air flows of 4-stages oven

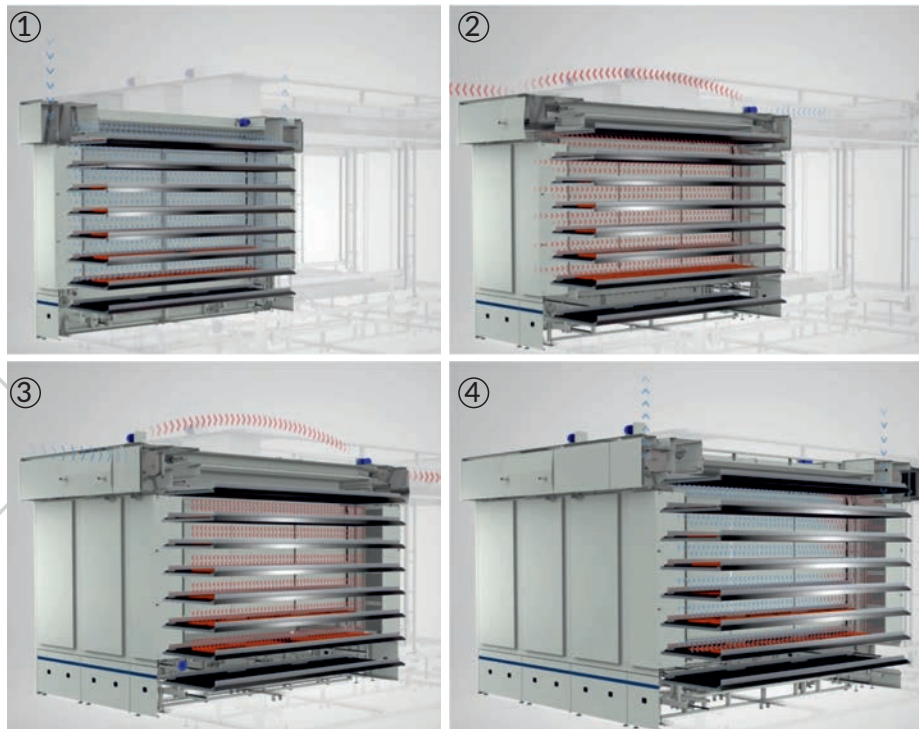

Suction hood  
Air accessible through  
side door



Intake hood  
Air accessible through  
side door



# FLEXI OVEN

New flexible oven

Flexible system of the drying level, it can be set level-by-level, flexibility in the management just like a real storage.

For flexible drying both of different drying time and for pieces of different height.

For flexible oven of small capability (just in-time) or combined oven-storage of big capability (high production and just in-time)



## PLUS



Independent on-off air flow (flash off or drying) for each tray



Flexible Solution



Water base and solvent paint drying



Energy Recovery



Independent drying time for every bar-tray



Covered bar-tray for high quality, Glossy



Patent pending



Storage or productive buffer



Also settable for small quantities



watch the video

# SMART SOLUTION

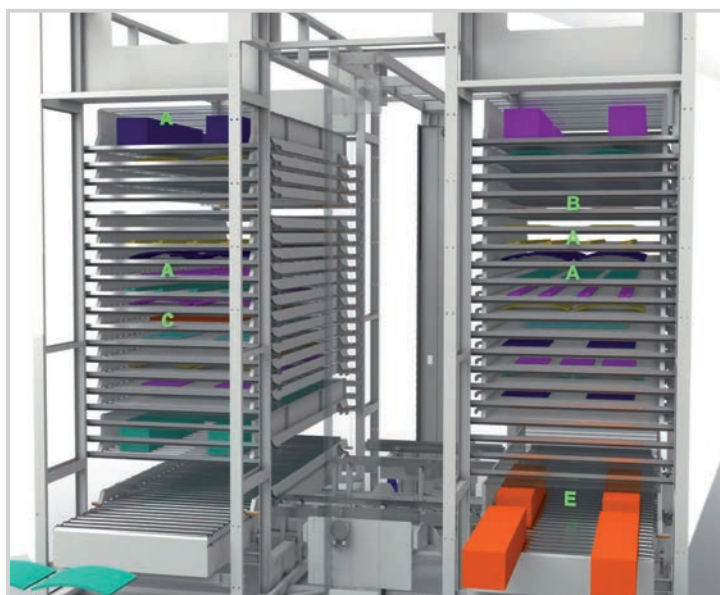
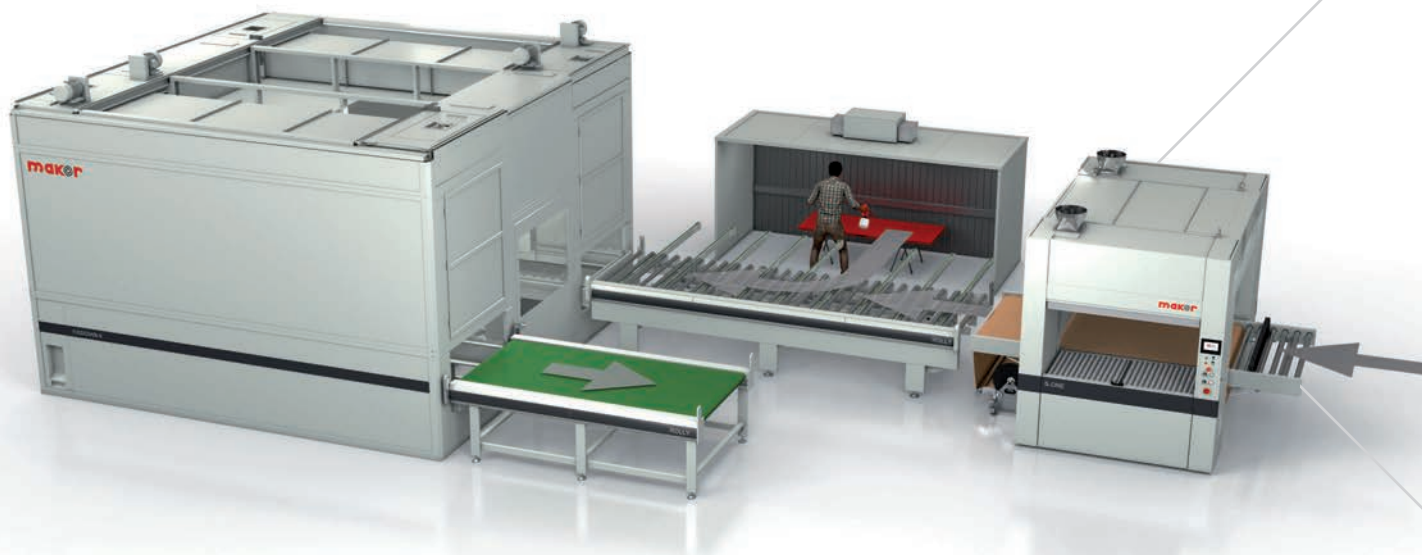

## MODELS AND FUNCTIONING MODE

- The tray moves with the pieces inside
- Total cover of the tray for quality finishing, glossy included
- Possibility to select the dwelling time (even different for every tray)
- Cycle time equal to 40 sec, that in the version with 5.5m tray allows feeding in continuous up to 8 m/min

## OFF-LOAD MODE

- FIFO (like in the standard oven)
- At set time (every bar-tray is evacuated after the time set)
- Per order (independently for the entrance order, the trays of one order are off-loaded)
- These modes can be realized with any sequence

## MODULARITY

- Possibility to remove/add by hand trays to manage the space dedicated to different thickness
- Height from 4.2m (20 trays) to 6.5m (50 trays)
- Up to 3 unities in line
- Tray length 3.6m or 5.5m

## AIR FLOWS AND THERMO CONDITIONS

- Air intake from ambient or from one CTA (air treating unit)
- Air warmed by inner coils and available on every tray
- Management from recipe to have, on every tray, laminar air or still air (optional)
- Manual recirculation of emission air or by humidity control system (optional)



Plant for glossy lacquered doors - 2 stages flash-off oven - 6 stages drying oven

Link to the website



We are the finishing specialist, leader for 50 years. Since 1968 we create and sell technology.



**makor**

Via Casalpiano, 9  
53048 Sinalunga (SI) - Italy  
Tel. +39 0577 634011  
makor@makor.it

**tecnolegno**

Via Benucci, 23  
61122 Pesaro - Italy  
Tel. +39 0721 23600  
info@tecnolegnoitaly.it

**comar**

Via F. Turati, 21  
53048 Sinalunga (SI) - Italy  
Tel. +39 0577 679998  
comar@makor.it