

# Nesting. One procedure. Many possibilities.

**HE HOMAG**

**Our CNC-Gantry Processing Center**  
CENTATEQ N-500

**YOUR SOLUTION**







## Nesting: one procedure – many possibilities...

**THE TYPICAL APPLICATIONS OF NESTING** are creation of carcass furniture, dividing and refining of furniture fronts and construction of frame furniture.

### CARCASS FURNITURE

- Routing of all components required for a carcass
- Drilling and grooving in just one cycle
- Clamping elements also provide horizontal drilling

### FURNITURE FRONTS

- Fast dividing and refining of furniture fronts from one workpiece – everything in one cycle!
- The application of units provides high flexibility for the further processing

### FRAME FURNITURE

- High degree of utilization due to easy handling of “free” formed parts

### MORE: HOMAG.COM



CENTATEQ N-500

## CONTENT

- 04 Highlights of the CENTATEQ N-500
- 06 All inclusive
- 08 Table field occupation
- 10 Options
- 12 Processing unit technology
- 14 Everything at a glance
- 16 Handling solutions
- 18 Option | Process optimization
- 20 Technical data
- 22 LifeCycleServices

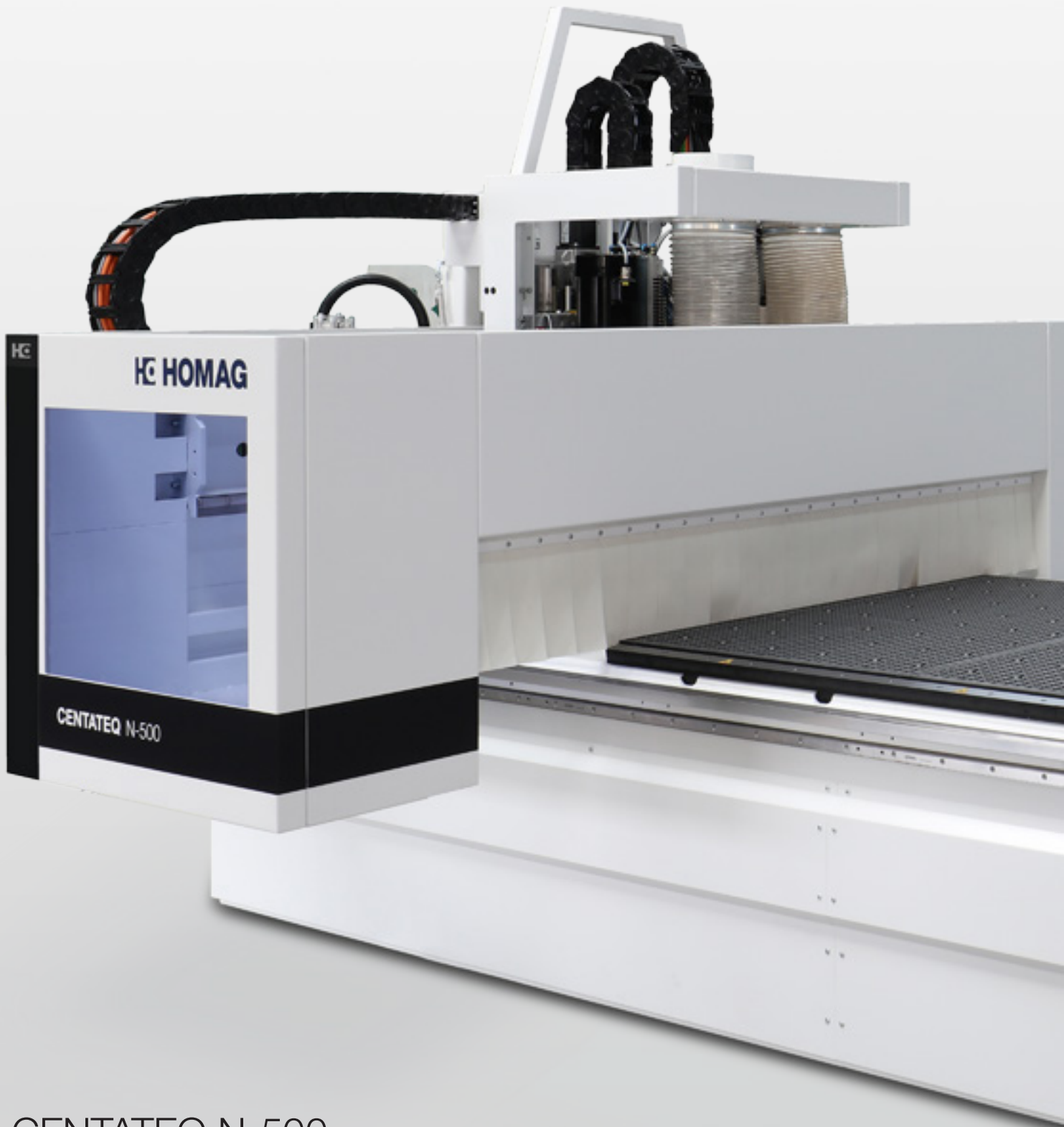

## CENTATEQ N-500 – The compact nesting machine in gantry design

Our nesting machines enable cutting-optimized processing and dividing of plate-shaped materials. Various possibilities for the automation of the material handling ensure a high time saving and more effective work.

## The highlights

- Gantry style – for highest precision over the total working width
- High acceleration
- Vector speed X/Y 96 m/min
- The whole working field is reachable with all processing tools
- Electronic surveillance of all stops
- Side stop guides (optional)
- 14-fold tool changing system incl. pick-up (optional)
- Optimization software (optional)
- Remaining parts handling (optional)

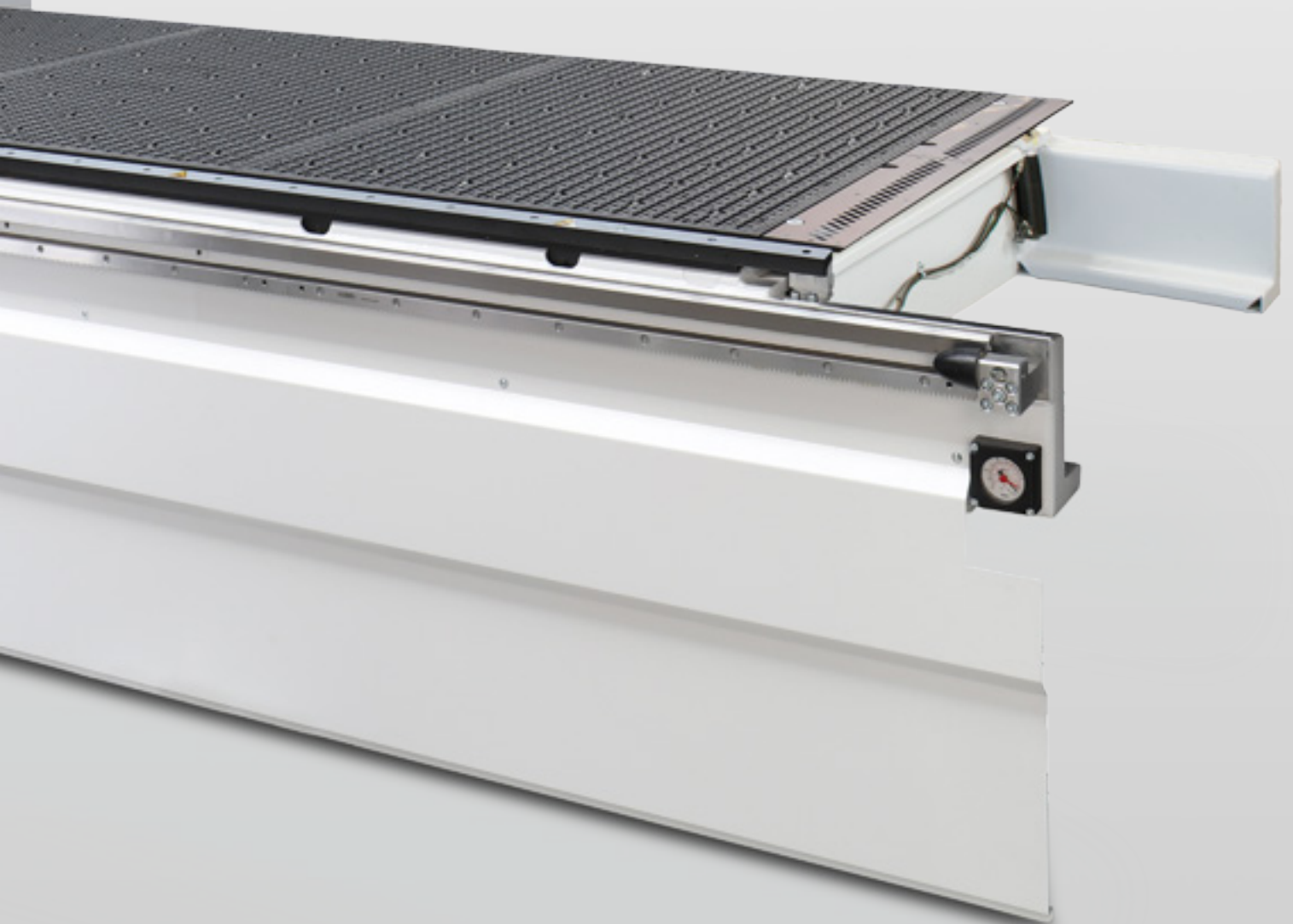

## CENTATEQ N-500 – Highlights as standard

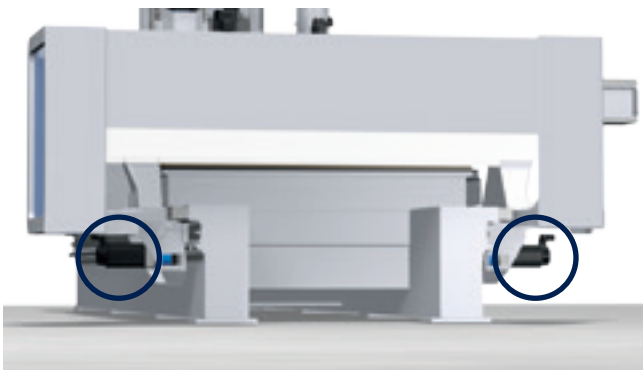

### Synchronous drive

- 2 synchronized digital servo-drives in X-direction guarantee highest processing quality

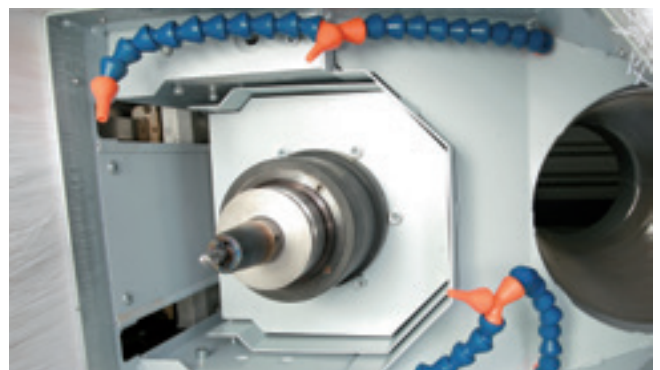

### Configuration

- Standard: 13,4 HP (10 kW) HSK routing spindle
- Optional: 17,7 HP (13,2 kW) HSK routing spindle

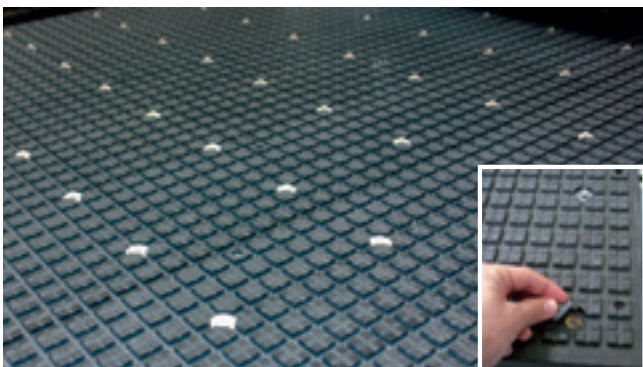

### MATRIX table Pro Plus

- High flexibility
- With grid grooves for clamping of templates or workpieces. Grid grooves for inlaying of a rubber sealing.

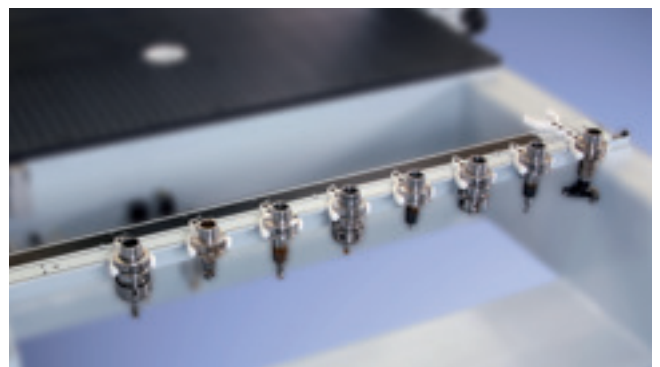

### Tool changing system

- Depending on working field in standard:  
CENTATEQ N-500 / 480 = 7 places  
CENTATEQ N-500 / 512 = 8 places  
CENTATEQ N-500 / 612 = 10 places  
CENTATEQ N-500 / 714 = 12 places

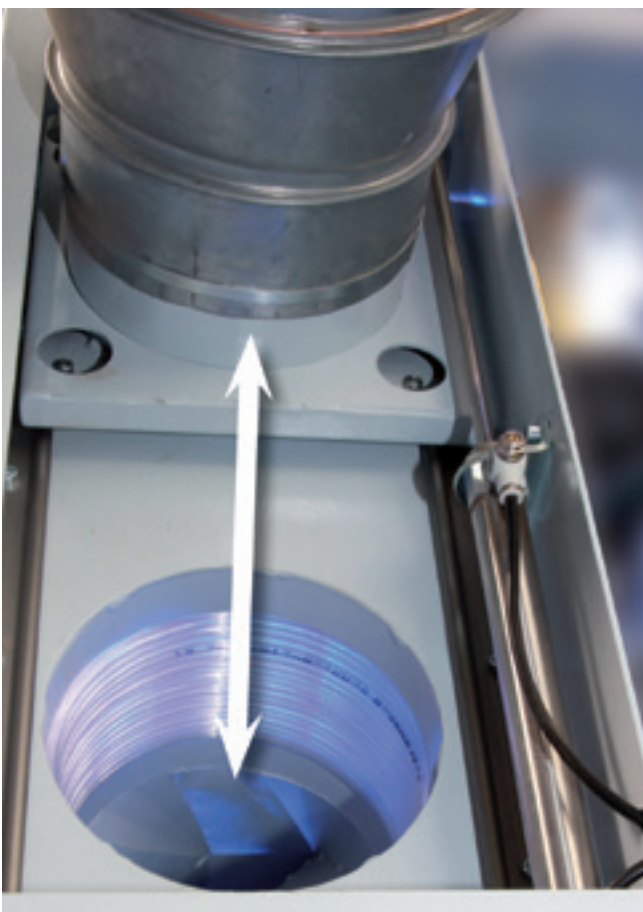
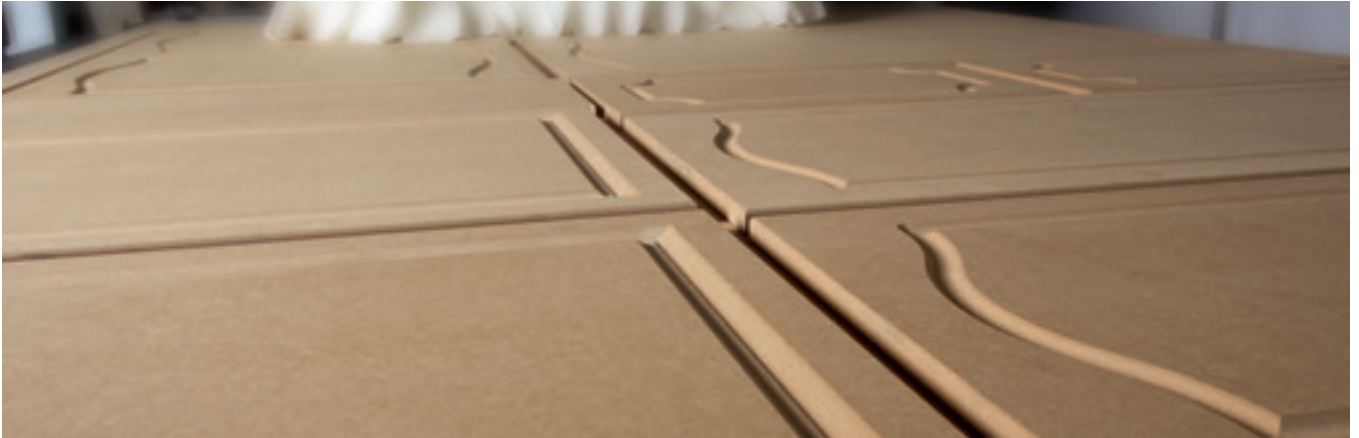

**Program-controlled extraction connection**

- For an optimum dust extraction and economic use of extraction energy (ecoPlus)

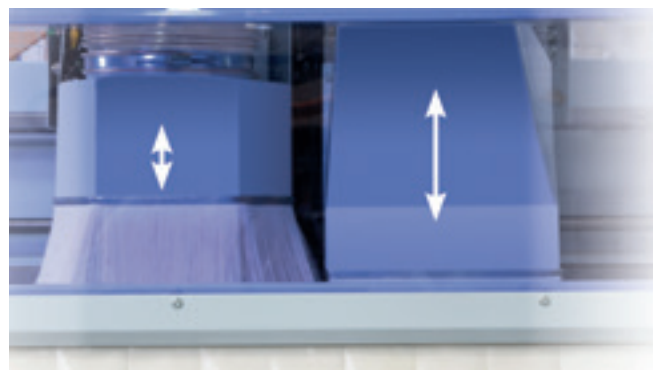

**2 CNC-controlled Z-axes in combination with drilling block**

- Optimal dust extraction and bigger operative range for processing units
- Weight distribution of the mass (processing units) to the two Z-axes = more stability, higher processing quality

**YOUR BENEFITS:**

**1.** Proven components for high quality standards

**2.** Optimal design of the tool changing places

**3.** Clean nesting by optimized extraction

# CENTATEQ N-500 – Efficient table field occupation by MATRIX Pro Plus

By automatically selecting and deselecting the table field occupation, the vacuum is activated in the required area and is effective where it is needed. The areas are optimally matched to the established range of boards.

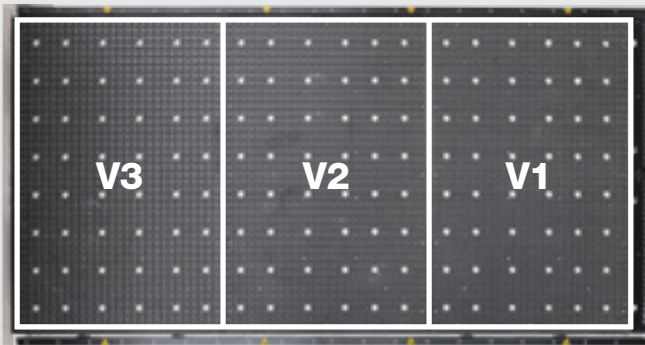

Segmentation of vacuum zones on the example of table size  
**1.250 x 2.520 mm | 4 x 8 ft**

- Segmentation in 3 fields
- 2,6 x 4 ft
- 5,2 x 4 ft
- 8,4 x 4 ft

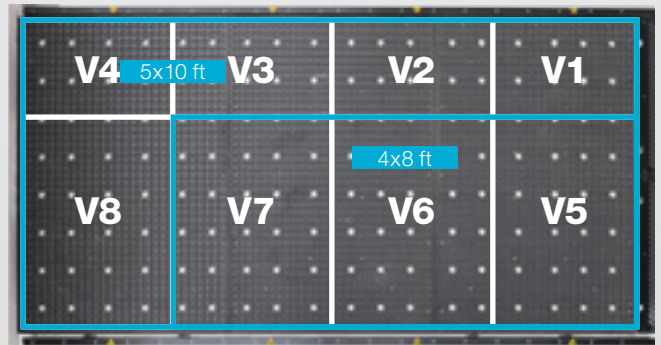

Segmentation of vacuum zones on the example of table size  
**1.550 x 3.100 mm | 5 x 10 ft**

- Segmentation in 8 fields
- 4 x 8 ft, 4 x 10 ft
- 5 x 8 ft, 5 x 10 ft

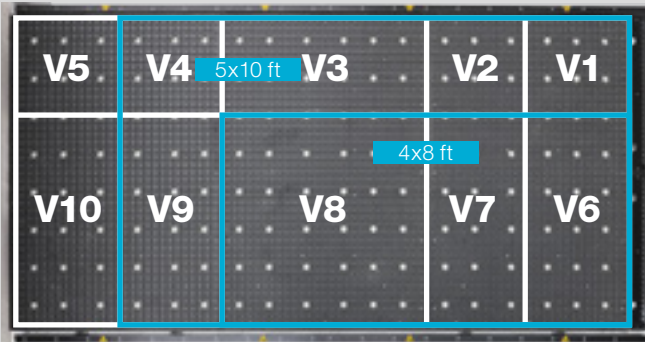

Segmentation of vacuum zones on the example of table size  
**1.550 x 3.700 mm | 5 x 12 ft**

- Segmentation in 10 fields
- 4 x 8 ft, 4 x 10 ft, 4 x 12 ft
- 5 x 8 ft, 5 x 10 ft, 5 x 12 ft

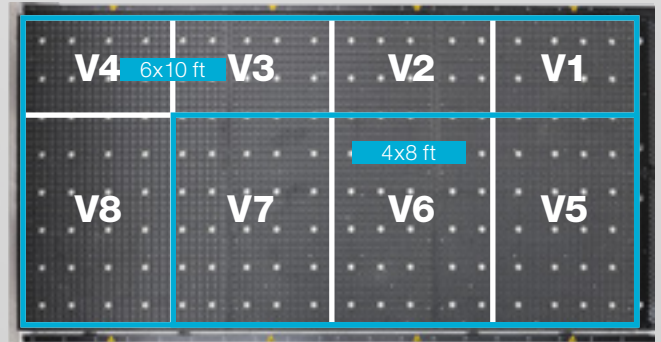

Segmentation of vacuum zones on the example of table size  
**1.850 x 3.100 mm | 6 x 10 ft**

- Segmentation in 8 fields
- 4 x 8 ft, 4 x 10 ft
- 6 x 8 ft, 6 x 10 ft

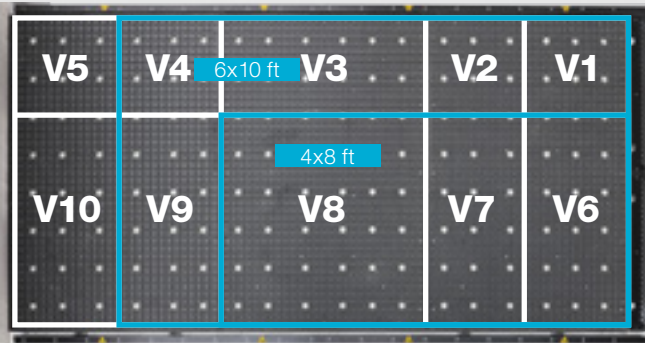
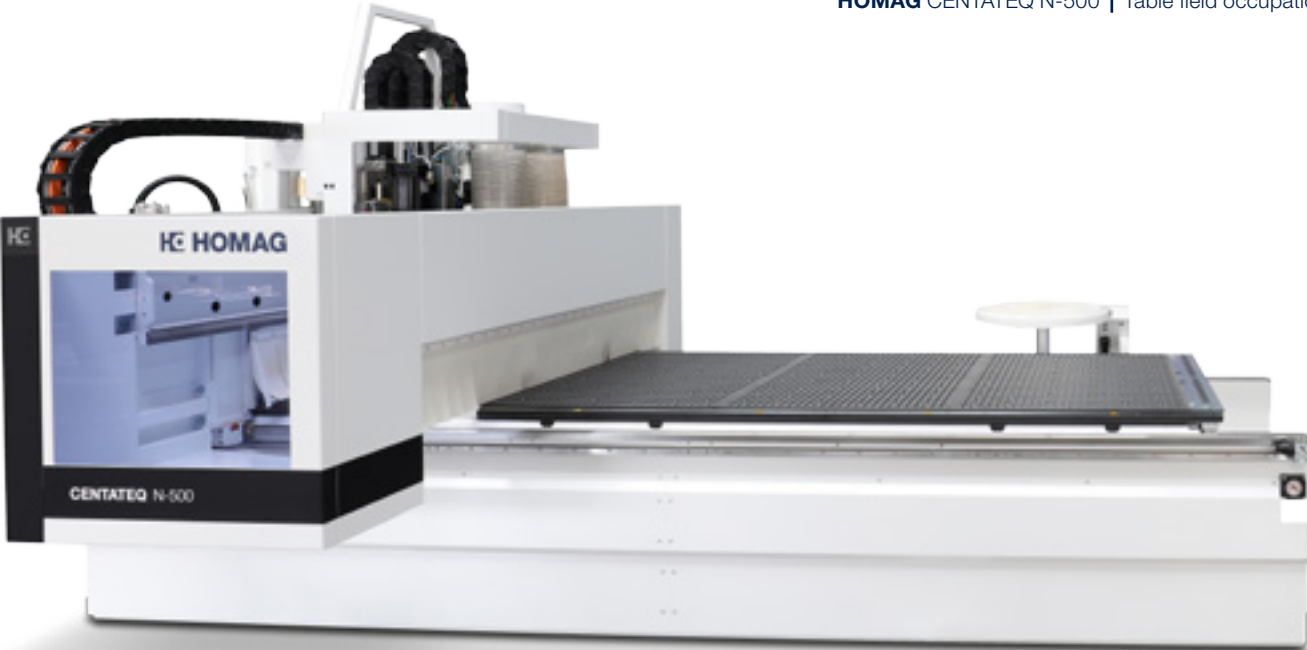

Segmentation of vacuum zones on the example of table size **1.850 x 3.700 mm | 6 x 12 ft**

- Segmentation in 10 fields
- 4 x 8 ft, 4 x 10 ft, 4 x 12 ft  
6 x 8 ft, 6 x 10 ft, 6 x 12 ft

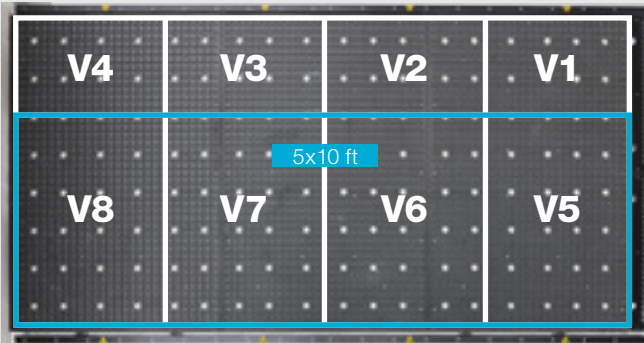

Segmentation of vacuum zones on the example of table size **2.250 x 3.100 mm | 7 x 10 ft**

- Segmentation in 8 fields
- 5 x 8 ft, 5 x 10 ft  
7 x 8 ft, 7 x 10 ft

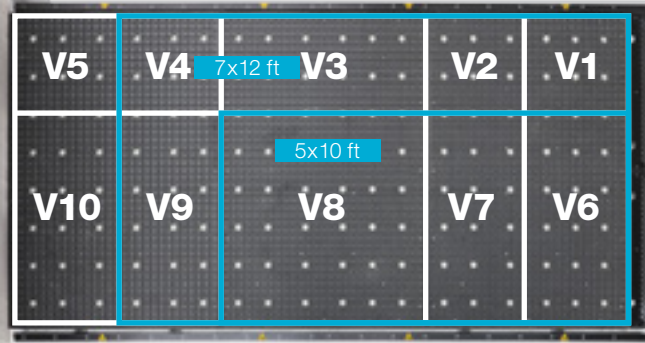

Segmentation of vacuum zones on the example of table size **2.250 x 4.300 mm | 7 x 14 ft**

- Segmentation in 10 fields
- 5 x 10 ft, 5 x 12 ft, 5 x 14 ft  
7 x 10 ft, 7 x 12 ft, 7 x 14 ft



## Options

**WOULD YOU LIKE SOMETHING EXTRA?** Our options provide all opportunities for a perfect adjustment of your nesting machine to your requirements.

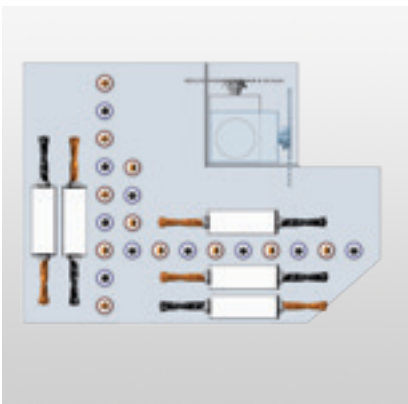

### High-Speed 7500 Drilling block | 21 spindles

- 21 vertical drilling spindles
- 6 horizontal drilling spindles in X
- 4 horizontal drilling spindles in Y
- 1 grooving saw  $\varnothing$  125 mm (0° / 90°)

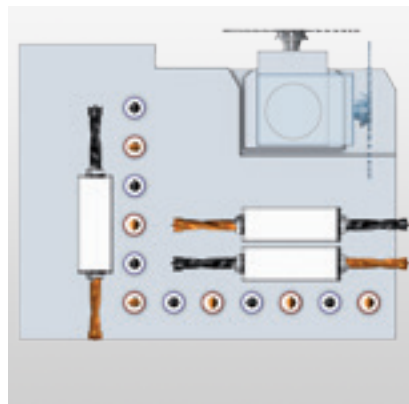

### High-Speed 7500 Drilling block | 12 spindles

- 12 vertical drilling spindles
- 4 horizontal drilling spindles in X
- 2 horizontal drilling spindles in Y
- 1 grooving saw  $\varnothing$  125 mm (0° / 90°)



### High-Speed 7500

- Spindles with 1500 - 7500 RPM incl. the patented quick change system

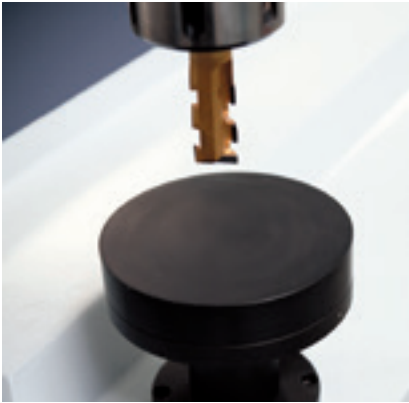

**Tool length control**

- Following the tool change a tool length control is carried out and compared with the integrated tool data file



**Tool changer**

- Tool changing system, fixed behind the machine, 14, 28 or 42 places



**Tool box »STARTER KIT«**

- Top equipment – from the very start

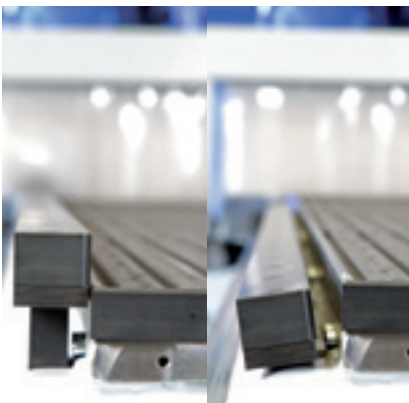

**Lowerable fence guide**

- Suitable for safe outfeed of workpieces



**Extension stop system**

- 4 pneumatically lowerable aluminium stop cylinders (in front right or in front left)



**Clamping elements**

- Different clamping elements available as option

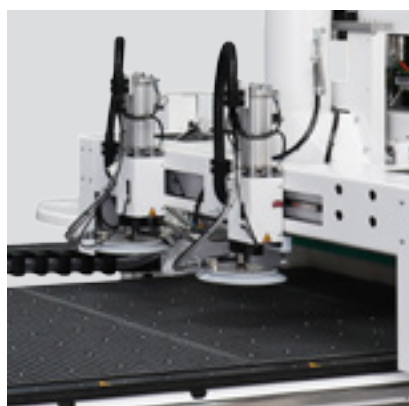

**Vacuum lever for raw panel positioning**

- For automatic positioning of the raw panels against the fence guide



**Barcode connection**

- Barcodescanner / -software
- Supported barcodes:  
1D – Barcode  
2D – Data Matrix Code
- Every workpiece is exactly identified for the further workpiece flow



## Processing unit technology

**INNOVATION. PRECISION. PASSION.** Over 20 years of experience in the development of units are reflected in the advanced stage of today's unit engineering. The HOMAG units are distinguished by their extreme rigidity, outstanding precision and stability.



**C-axis (0-360°)** for the use of units



**Extension to FLEX5** consisting of FLEX5 interface and FLEX5 unit

**HIGH PERFORMANCE UNITS** ensure optimum lubrication of gear components for prolonged operations.

**FLEX5**



**HIGH PERFORMANCE**  
Drilling/Sawing/Routing



**HIGH PERFORMANCE**  
Sawing Ø 220 mm



**HIGH PERFORMANCE**  
Planing unit | Tool diameter max. 120 mm



**Drilling/Routing/Sawing**  
2 spindles  
(also available as HIGH PERFORMANCE unit)



**Drilling/Sawing**  
swivelling (0° - 90°), Ø 180 mm  
(also available as HIGH PERFORMANCE unit)

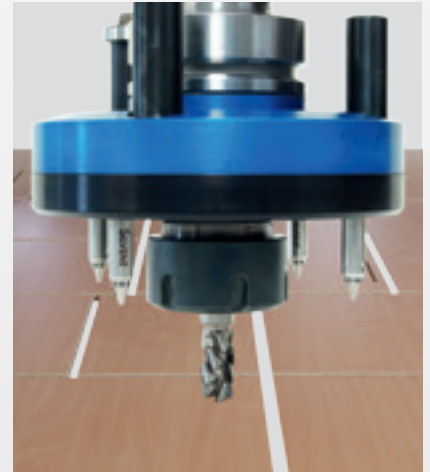

**Routing**  
with 4-fold blowing nozzle



**Tracing routing unit with tracing ring**  
Ø 70 mm | Ø 130 mm



**Cutting unit**  
1 cutting blade | 10 mm cutting surface

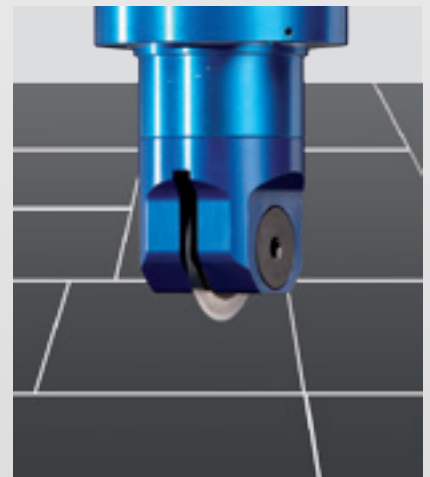

**Foil cutting unit**  
1 cutting wheel | Ø 75 mm



**Drilling/Routing**  
swivelling cranked (0° - 90°),

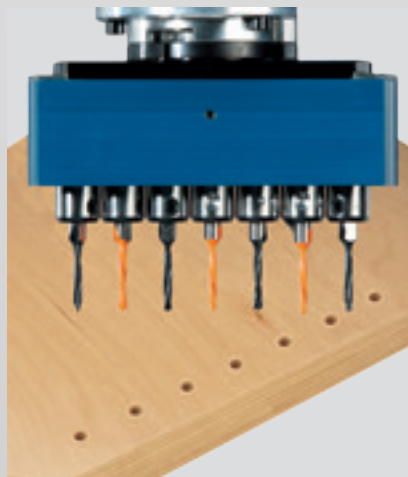

**Drilling**  
7 spindles, 25 mm raster

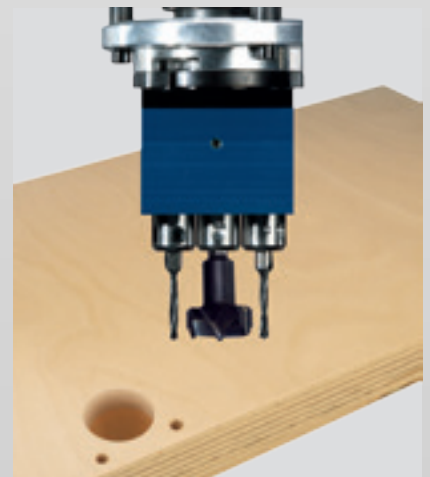

**Fitting drilling head**  
3 spindles

# CENTATEQ N-500 | Everything at a glance...

With these packages you are up to all tasks. The choice is yours.

	Table sizes							Tool changing spindle				Unit interfaces			Drilling gear				Drilling gear additional			Tool changing system									
	4 x 8 ft	5 x 10 ft	5 x 12 ft	6 x 10 ft	6 x 12 ft	7 x 10 ft	7 x 14 ft	10 kW air-cooled (standard)	13,2 kW air-cooled (optional)	11 kW liquid-cooled (optional)	16 kW liquid-cooled (optional)	360° adjusting axis	C-axis	C-axis for Flex5 unit	V12	V21	V12 incl. quick-change system	V21 incl. quick-change system	Horizontal drilling unit with 2 spindles in X direction	Horizontal drilling unit with 2 spindles in Y direction	Grooving saw 0°/90° swivelling	4 x 8 ft	5 x 10 ft	5 x 12 ft	6 x 10 ft	6 x 12 ft	7 x 10 ft	7 x 14 ft			
Basic machine	●	●	●	●	●	●	●	✓	○	○	○	○	○	○	○	○	○	○	○	○	○	○	○	○	7	8	8	10	10	12	12
Nesting concept outfeed	●	●	●	●	●	●	●	✓	○	○	○	○	○	○	○	○	○	○	○	○	○	○	○	○	7	8	8	10	10	12	12
Nesting concept 1	●	●	●	●	●	●	●	✓	○	○	○	○	○	○	○	○	○	○	○	○	○	○	○	○	7	8	8	10	10	12	12
Nesting concept 1R	●	●	●	●	●	●	●	✓	○	○	○	○	○	○	○	○	○	○	○	○	○	○	○	○	7	8	8	10	10	12	12
Nesting concept 2	●	●	●	●	●	●	●	✓	○	○	○	○	○	○	○	○	○	○	○	○	○	○	○	○	7	8	8	10	10	12	12
Nesting concept 3	●	●	●	●	●	●	●	✓	○	○	○	○	○	○	○	○	○	○	○	○	○	○	○	○	7	8	8	10	10	12	12
Nesting concept 3R	●	●	●	●	●	●	●	✓	○	○	○	○	○	○	○	○	○	○	○	○	○	○	○	○	7	8	8	10	10	12	12



Tool changer disk type with pick-up fixed (optional)			Automation						Equipment													
14-fold	28-fold	42-fold	Conveyor belt	Roller track	Lifting table	Infeed roller table	Barcode printer	tapio-ready	PowerControl with powerTouch	Synchronous drive	Vacuum arms for panel positioning	Push-Off device for workpieces	Extraction in the outfeed from below	Extraction in the outfeed from above	Vacuum system	Clamping elements	Air cushion function	Air-conditioning	Manual labeling terminal	Simultaneous pull-in and push-out		
<input type="radio"/>	<input type="radio"/>	<input type="radio"/>	-	-	-	-	-	✓	✓	✓	-	-	-	-	✓	<input type="radio"/>	<input type="radio"/>	<input type="radio"/>	<input type="radio"/>	<input type="radio"/>	-	
<input type="radio"/>	<input type="radio"/>	<input type="radio"/>	✓	-	-	-	-	✓	✓	✓	-	✓	<input type="radio"/>	<input type="radio"/>	✓	<input type="radio"/>	<input type="radio"/>	<input type="radio"/>	<input type="radio"/>	<input type="radio"/>	-	
<input type="radio"/>	<input type="radio"/>	<input type="radio"/>	✓	✓	-	-	-	✓	✓	✓	✓	✓	✓	<input type="radio"/>	✓	<input type="radio"/>	<input type="radio"/>	<input type="radio"/>	<input type="radio"/>	<input type="radio"/>	<input type="radio"/>	
<input type="radio"/>	<input type="radio"/>	<input type="radio"/>	✓	✓	-	✓	-	✓	✓	✓	✓	✓	✓	<input type="radio"/>	✓	<input type="radio"/>	<input type="radio"/>	<input type="radio"/>	<input type="radio"/>	<input type="radio"/>	<input type="radio"/>	
<input type="radio"/>	<input type="radio"/>	<input type="radio"/>	✓	✓	✓	-	-	✓	✓	✓	✓	✓	✓	<input type="radio"/>	✓	<input type="radio"/>	<input type="radio"/>	<input type="radio"/>	<input type="radio"/>	<input type="radio"/>	<input type="radio"/>	
<input type="radio"/>	<input type="radio"/>	<input type="radio"/>	✓	✓	✓	-	✓	✓	✓	✓	✓	✓	✓	<input type="radio"/>	✓	<input type="radio"/>	<input type="radio"/>	<input type="radio"/>	<input type="radio"/>	<input type="radio"/>	<input type="radio"/>	
<input type="radio"/>	<input type="radio"/>	<input type="radio"/>	✓	✓	-	✓	✓	✓	✓	✓	✓	✓	✓	<input type="radio"/>	✓	<input type="radio"/>	<input type="radio"/>	<input type="radio"/>	<input type="radio"/>	<input type="radio"/>	<input type="radio"/>	

Standard: ✓ Available: ● Option: ○

# We have the solution for your nesting requirements!

With the HOMAG nesting solutions you are always well-advised. Whether the workpieces should be fed by hand, by lifting carriage or by storage – we have always the proper concept for your application. You wish to identify, for example, the workpiece flow exactly by barcode? No problem! With our plug & play features, we enable the successive expansion of the machine from concept 1 onwards.

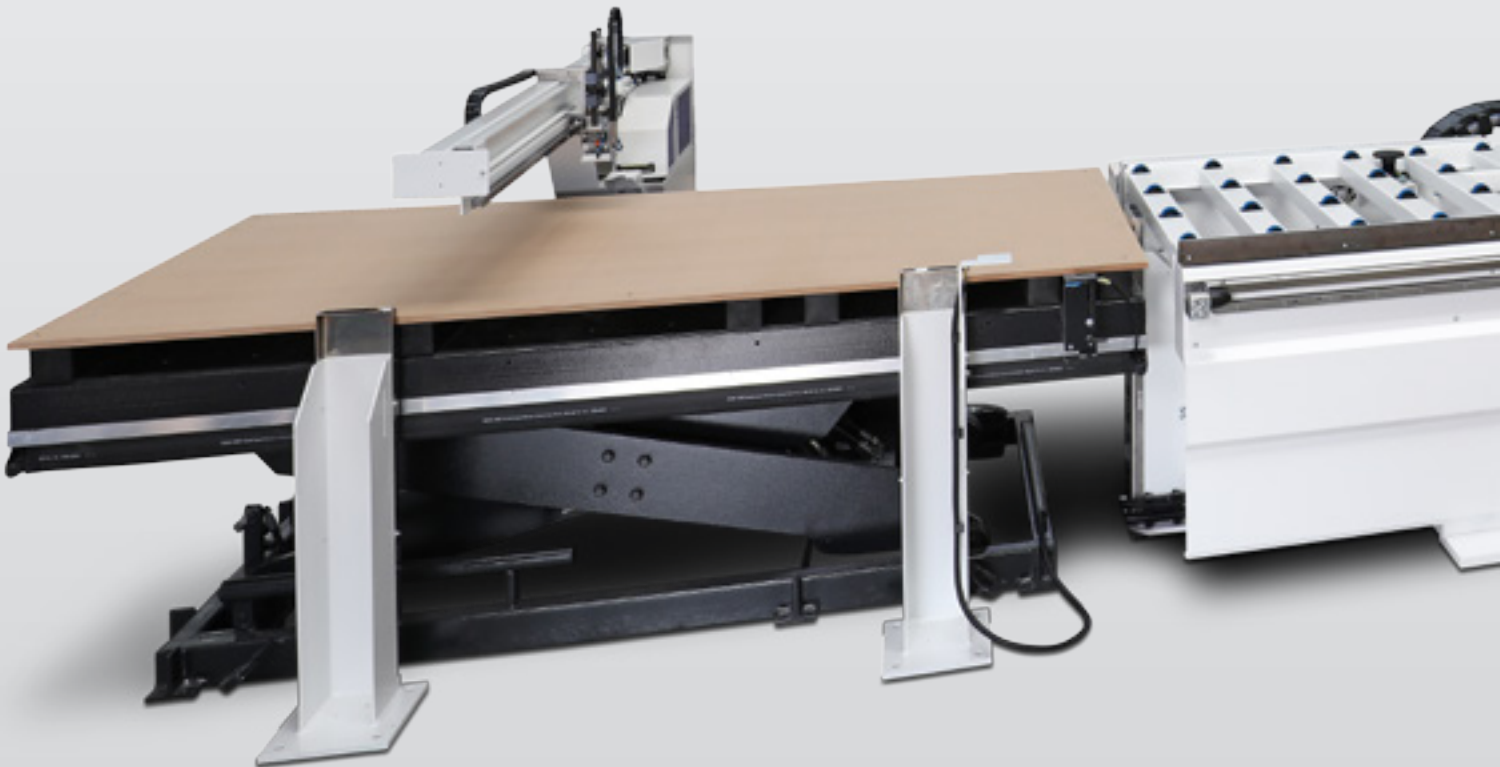

## Concept 3

- Optimized with new printing system



## Label printing system

- Automatic labelling of raw boards before processing
- Modular concept – plug & play (retrofitable)
- Fast – 60 m/s in X-direction



## Air cushion function

- Optimal and smooth feeding of workpieces for easy handling

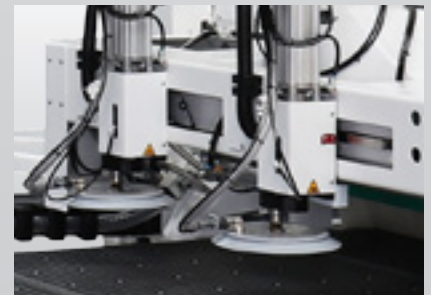

## Infeed- and push-off function

- For simultaneous infeed of the raw material and push-off of processed workpieces



## Handling solutions for CENTATEQ N-500

Basic machine

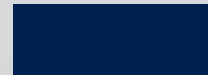

Basic machine  
with outfeed belt



Basic machine with outfeed belt  
incl. preparation for external infeed



Basic machine  
with outfeed belt and conveyor  
(available with lift table or roller table)

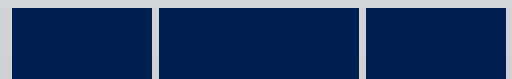

Basic machine  
with outfeed belt, conveyor and labelling system  
(Lift table or roller table)

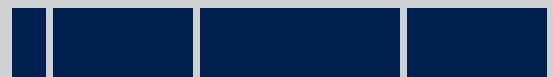

Integration in  
HOMAG Automation storage



### powerControl with powerTouch

- 21,5" Full-HD multitouch display with wide screen 16:9
- Provision of teleservice capability
- USB frontside bus
- Ethernet connection 10/100 Mbit
- Ergonomic hand terminal

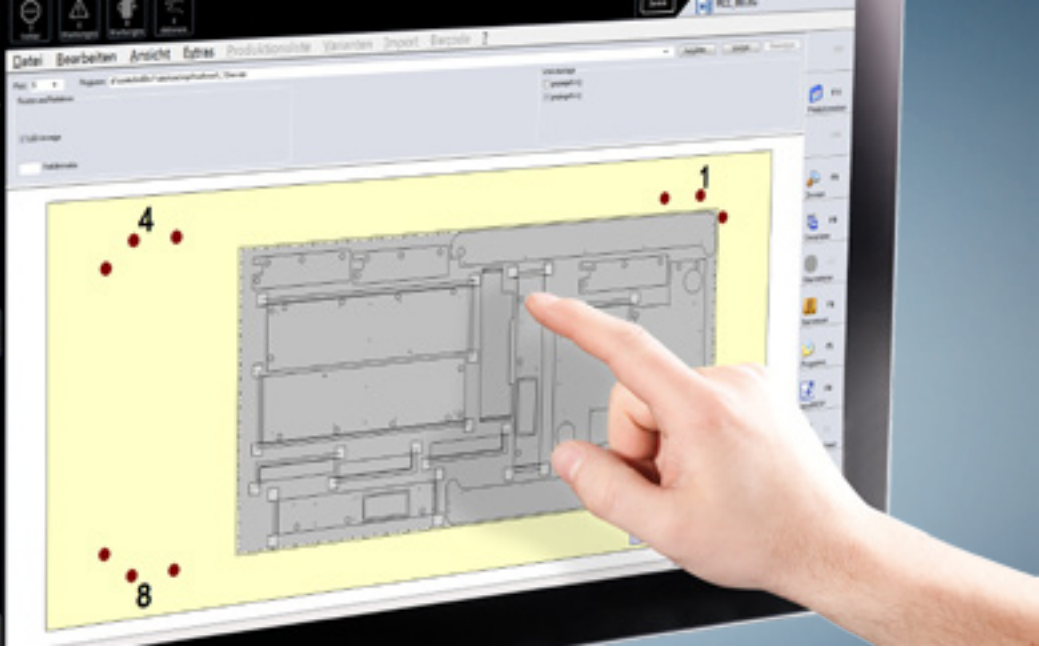

## Software | Machine

Our machines are equipped with everything needed for productive use as standard. In addition, a wide range of software modules can be supplemented to create the optimum configuration.

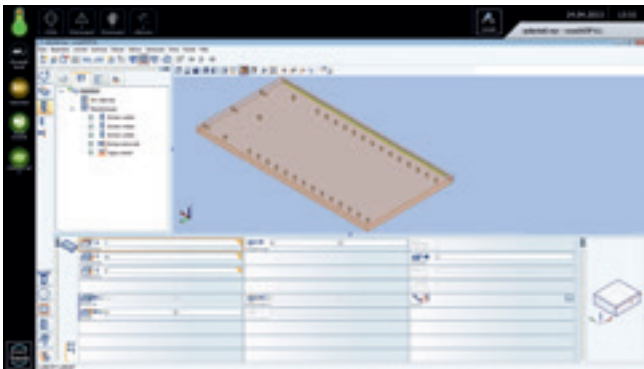

### woodWOP

- Modern software based on Windows®
- Import of CAD files in DXF format
- More than 30,000 installations worldwide
- Worldwide largest forum for woodWOP



### Production list software

- For management and creation of product lists for individual manufacturing



### Slot assignment

- Simple control of main machine functions through soft keys
- Graphical loading

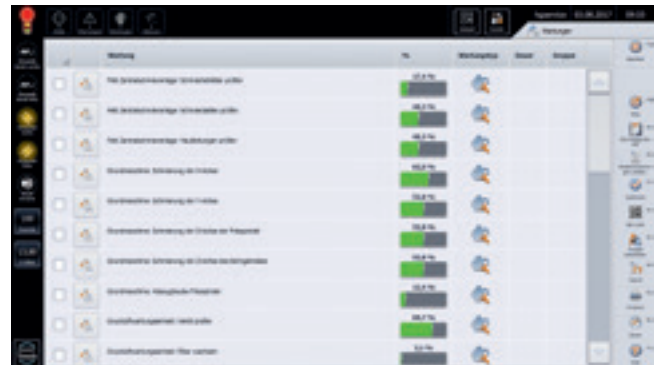

### MMR Basic

- Machine Data Recording – collecting and evaluating machine states via time meter and event meter
- Display and logging of maintenance measures

# Process optimization

**CUT RITE, THE OPTIMIZATION SOFTWARE OF THE HOMAG**, is used for cutting boards on sawing machines as well as nesting machines. The modular structure of the software allows users already controlling their sawing machine via Cut Rite to integrate the nesting module without problems. Plus, customer processes can be made even more efficient by woodCAD|CAM and residual parts management.

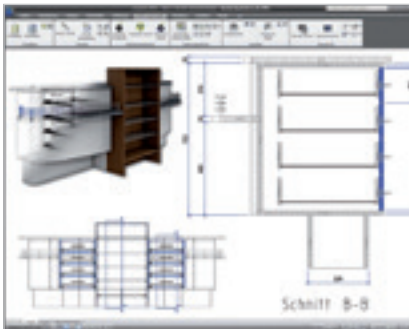

### woodCAD|CAM

- Parametric design in 3D
- Seamless data flow in operation
- Bill of materials, cutting to size and cost estimation
- CNC data for HOMAG Group machines
- Bar code generation
- Photorealism for sales negotiations



### Residual parts management | Basic

- Labels for residual parts from Cut Rite
- Manual management

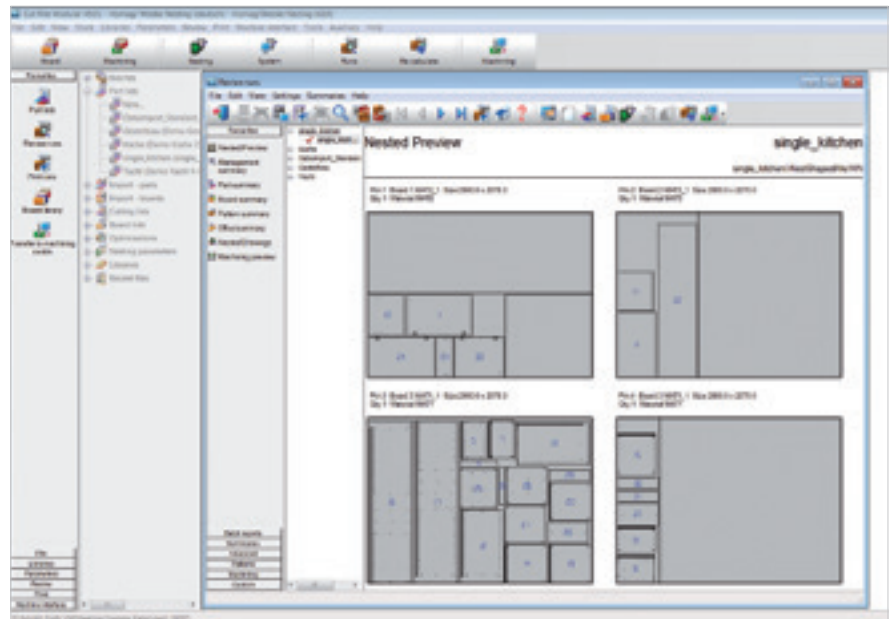

### Optimization software: woodNest Basic and Cut Rite Nesting

- Optimization and generation of cutting plans for rectangular and free-formed workpieces (woodNest Basic: manually | Cut Rite: automatically)
- Functions with Cut Rite:
  - Import of parts lists, e.g. from Excel, or direct import of woodWOP programs
  - Additional milling strategies “bars”, “common line” and “stay down”
  - Includes material management, parts sorting by material type, and label printing in the office
  - Manual editing of cutting plans



### Residual parts management | Advanced

- Automatic management within the storage database
- Manual positioning in automatic mode
- Labels for residual parts can be produced on the machine itself

### Residual parts management | Professional

- Automatic residual parts handling for nesting concepts in conjunction with storage solutions from HOMAG Automation
- Only in combination with residual parts management | Advanced

# Technical data

Our machines are equipped with everything needed for safe and effective operation.

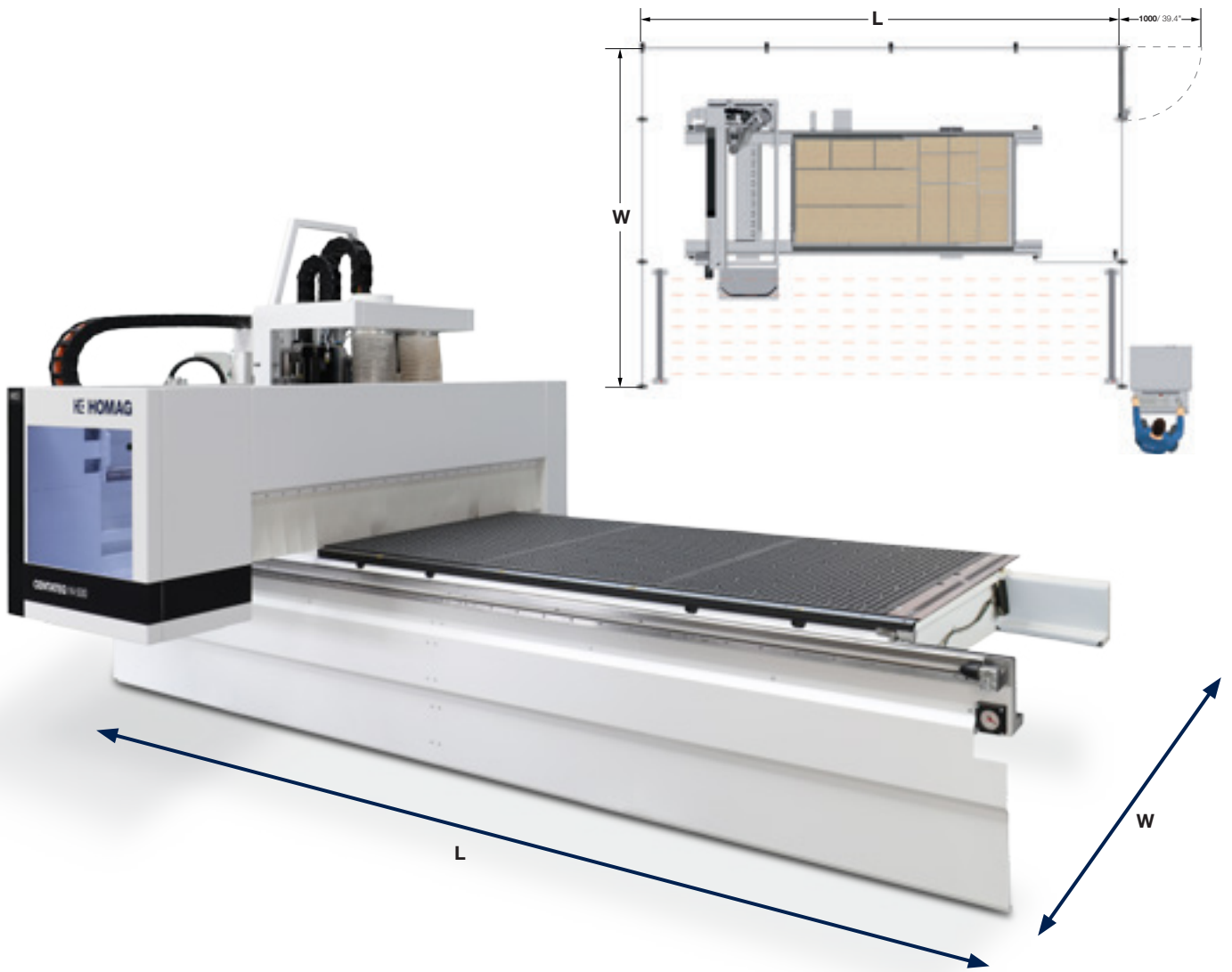

Vector speed X/Y - Z-axis	m/min	96 - 25
Compressed air connection	inch	R ½
Compressed air required	bar	7
Dust extraction port	mm	Ø 200*
Dust extraction volume	m³/h	min. 3.170*
Electrical power – total connection load	kW	27,5*

\*Basic machine

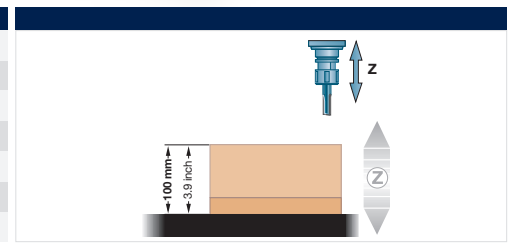

Working field		X	Y	Z
4 × 8 ft		2.520 / 99.2	1.250 / 49.2	100 / 3.9
5 × 10 ft		3.100 / 122.0	1.550 / 61.0	100 / 3.9
5 × 12 ft		3.700 / 145.7	1.550 / 61.0	100 / 3.9
6 × 10 ft		3.100 / 122.0	1.850 / 72.8	100 / 3.9
6 × 12 ft		3.700 / 145.7	1.850 / 72.8	100 / 3.9
7 × 10 ft		3.100 / 122.0	2.250 / 88.6	100 / 3.9
7 × 14 ft		4.300 / 169.3	2.250 / 88.6	100 / 3.9
mm/inch				
Travel range		Drilling gear		Routing unit
All table sizes	4-sided formatting possible	215 / 8.5		245 / 13.7
mm/inch				

Floor space incl. safety area**		L	W
<b>Manual concepts</b>			
Basic machine	4 × 8 ft	6.480 / 255.1	4.350 / 171.3
	5 × 12 ft	7.630 / 300.4	4.550 / 179.1
	6 × 12 ft	7.630 / 300.4	4.990 / 196.5
	7 × 10 ft	7.030 / 276.7	6.150 / 242.1
	7 × 14 ft	8.230 / 324.0	6.150 / 242.1
Nesting concept outfeed	4 × 8 ft	7.870 / 309.8	4.350 / 171.3
	5 × 12 ft	9.996 / 393.5	4.550 / 179.1
	6 × 12 ft	10.002 / 393.8	4.990 / 196.5
	7 × 10 ft	9.400 / 370.1	6.150 / 242.1
	7 × 14 ft	11.610 / 457.1	6.150 / 242.1
<b>Automatic concepts</b>			
Nesting concept 1	4 × 8 ft	8.220 / 323.6	5.150 / 202.8
	5 × 12 ft	10.400 / 409.5	5.440 / 214.2
	6 × 12 ft	10.400 / 409.5	5.840 / 229.9
	7 × 10 ft	9.750 / 383.9	6.150 / 242.1
	7 × 14 ft	11.960 / 470.9	6.150 / 242.1
Nesting concept 1R	4 × 8 ft	11.770 / 463.4	5.150 / 202.8
	5 × 12 ft	14.600 / 574.8	5.440 / 214.2
	6 × 12 ft	14.600 / 574.8	5.840 / 229.9
	7 × 10 ft	13.380 / 526.8	6.150 / 242.1
	7 × 14 ft	17.800 / 700.8	6.150 / 242.1
Nesting concept 2	4 × 8 ft	10.470 / 412.2	5.150 / 202.8
	5 × 12 ft	13.950 / 549.2	5.440 / 214.2
	6 × 12 ft	13.950 / 549.2	5.840 / 229.9
	7 × 10 ft	12.720 / 500.8	6.150 / 242.1
	7 × 14 ft	16.100 / 633.9	6.150 / 242.1
Nesting concept 3	4 × 8 ft	10.850 / 427.2	5.150 / 202.8
	5 × 12 ft	14.300 / 563.0	5.440 / 214.2
	6 × 12 ft	14.300 / 563.0	5.840 / 229.9
	7 × 10 ft	13.470 / 530.3	6.150 / 242.1
	7 × 14 ft	16.260 / 640.2	6.150 / 242.1
Nesting concept 3R	4 × 8 ft	12.400 / 488.2	5.150 / 202.8
	5 × 12 ft	15.600 / 614.2	5.440 / 214.2
	6 × 12 ft	15.600 / 614.2	5.840 / 229.9
	7 × 10 ft	14.670 / 577.6	6.150 / 242.1
	7 × 14 ft	18.200 / 716.5	6.150 / 242.1
mm/inch			

\*\* Dimensions for table sizes 5 × 10 ft and 6 × 10 ft on request



## HOMAG LifeCycleServices

The sale of our machines comes with all-in optimum service backup and individual advice. We support you with service innovations and products which are optimally tailored to your requirements. With short response times and fast customer

solutions we guarantee consistently high availability and economical production – over the entire life cycle of your machine.



### Remote Service

- Hotline support via remote diagnosis regarding control, mechanics and process technology. Thus the on-site service can be reduced by more than 90%!
- Mobile applications such as ServiceBoard reduce the costs through fast help in case of troubles by mobile live video diagnosis, online service message and the online spare parts shop eParts



### Spare Parts Service

- Identify, request and order spare parts around the clock via [www.eParts.de](http://www.eParts.de)
- Local availability of parts offered by our sales and service companies as well as sales and service partners all over the world
- Reduction of downtime through defined spare parts and wear parts kits



### Modernization

- Keep your machinery up-to-date and increase your productivity as well as your product quality. This is how you can meet tomorrow's requirements today!
- We support you with upgrades, modernization as well as individual consultancy and developments



**HOMAG Finance –  
precisely the right financing**

- We offer you tailored financing proposals for your machinery or plants. Our financial advice goes hand in hand with our expertise relating to technical questions. Your personal contact person will take care of the whole process.
- The benefit for you: The ability to invest without delay in new technologies and remain financially flexible.

**1,200**  
service employees around the world

**5,000**  
customers in training courses / year

**> 90%**  
less on-site-services through successful remote diagnosis

**> 150,000**  
machines, all electronically documented in 28 different languages – in eParts



**Training courses**

- The trainings perfectly suit to your requirements. Through this your machine operators can operate and maintain the HOMAG machines optimally.
- The training courses also include customer-specific training documents with practice-proven exercises

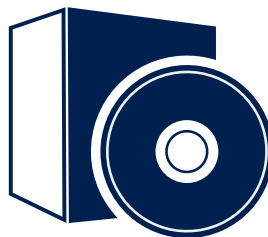

**Software**

- Telephone support and consultancy through software support
- Digitalization of your sample parts via 3D scanning saves time and money compared to new programming
- Subsequent networking of your machinery with intelligent software solutions ranging from construction to production



**Field Service**

- Increased machine availability and product quality by certified service staff
- Regular checks through maintenance / inspection guarantee the highest quality of your products
- We offer you the highest availability of technicians in order to reduce downtimes in case of unpredictable troubles

## **HOMAG Group AG**

info@homag.com

www.homag.com



## **YOUR SOLUTION**