

// WEIMA High-Powered Shredders WL(K) 10-20 Series

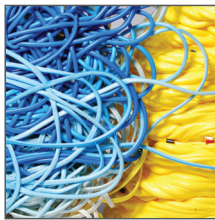
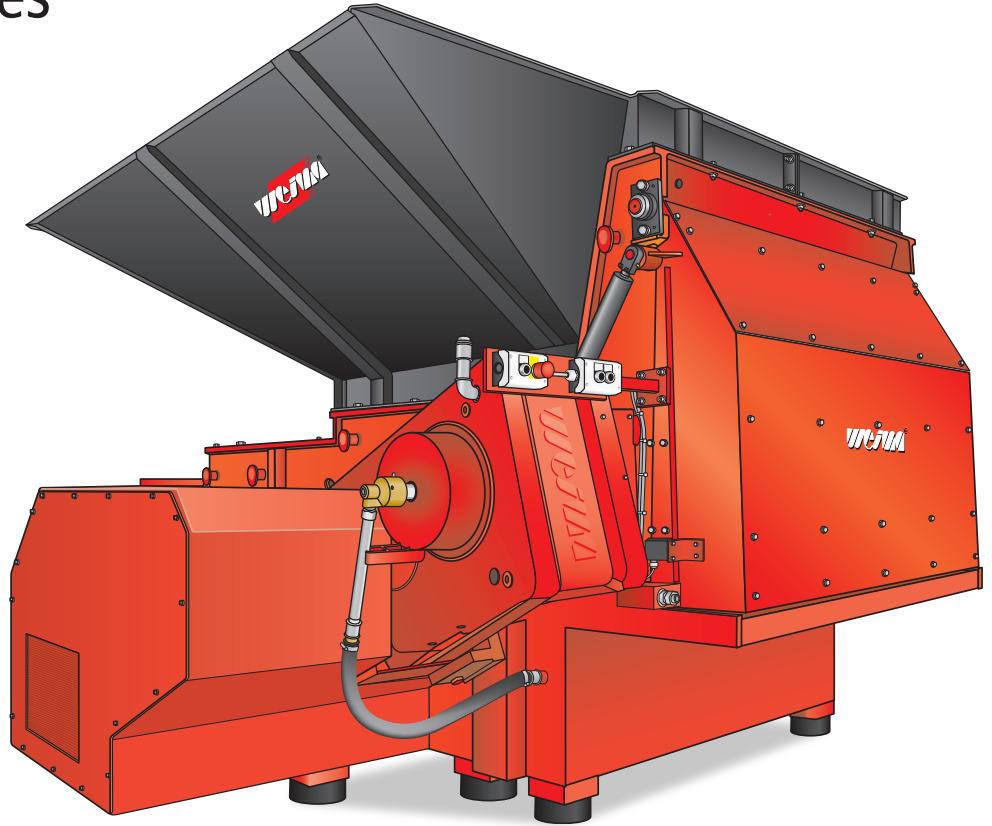

The Optimum Shredder for Maximum Throughout Rates

WEIMA America offers a diverse line of shredding and grinding equipment to the wood, plastic, paper and recycling industries. Our broad range of products include standard machines as well as custom solutions for any size reduction requirements. The WL(K) single-shaft shredders come in different configurations which can handle most materials including, PE, PP, film, sheets, rolls, carpet, wood and much more.

We're Tearing It Up

The WL(K) 10-20 shredders have machine openings from 39" – 78" wide. The material is loaded into the hopper and pressed against the rotor by the hydraulic ram. The rotor shreds the material until it can fall through the desired screen size. The multiple machine functions and available options are featured below.



CUSTOM HOPPERS

- Custom flared versions
- Hopper extensions
- Doghouse options
- Hopper lid
- Sound reduction



GEARBOX

- WEIMA gearbox design
- Hydraulic drives available
- Limit switch

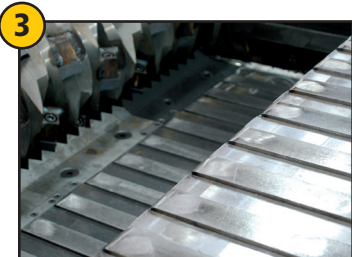

RAM

- Serrated version
- Ram extensions
- Ram comb

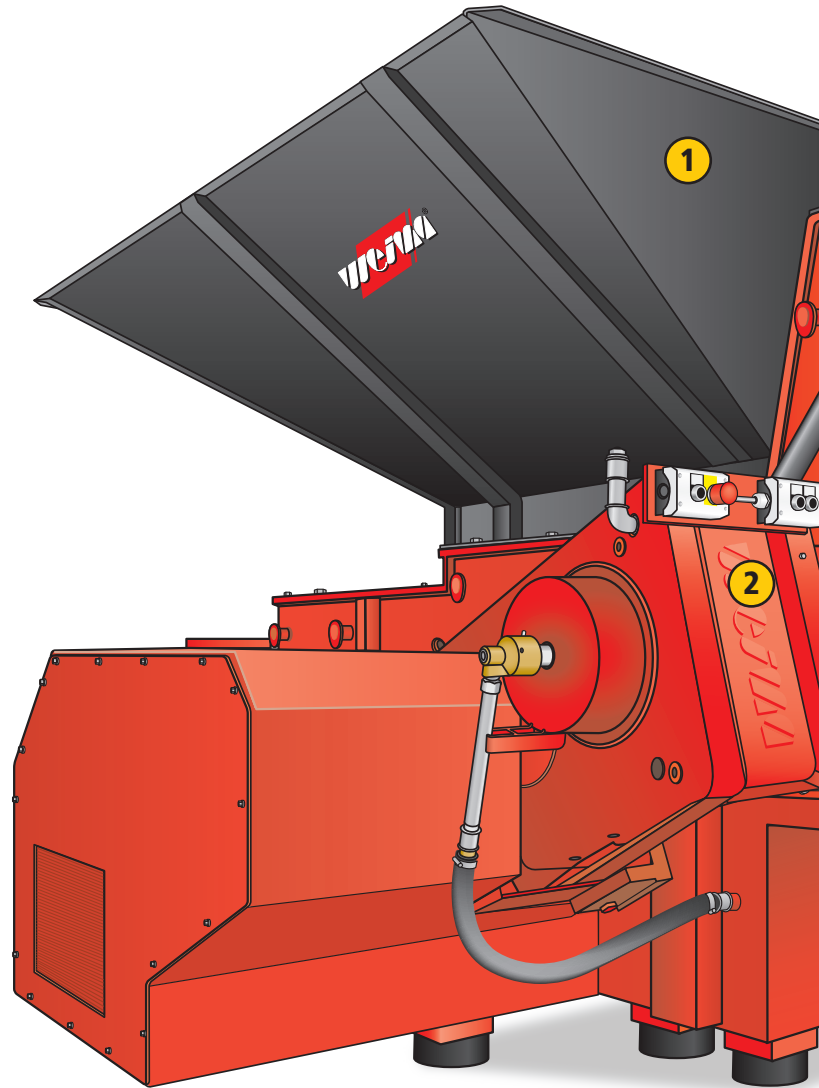

WEIMA's extensive line of equipment also includes: multi-stage systems, horizontal shredders and briquette presses

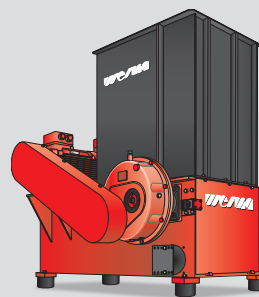

ECO

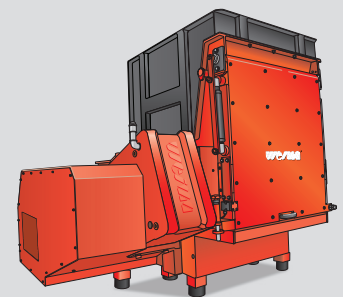

WL 10

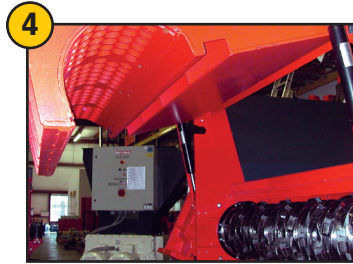
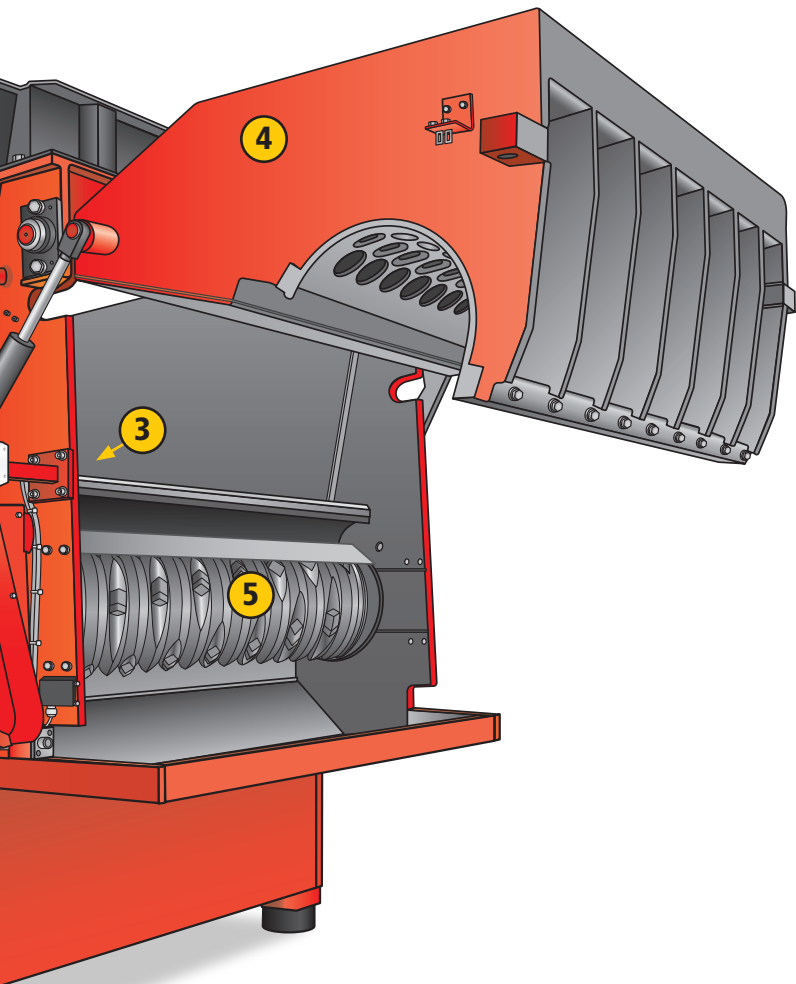

LIFT-UP DOOR (OPTIONAL)

- Easy access to the rotor and screen
- Maintenance and safety feature
- Only offered by WEIMA

ROTOR AND KNIVES

- Welded knife holders
- V-rotor – 4x indexable knives and broaching knives
- E-rotor for film and fiber
- Bolted knife holder available
- Vaudit protection available
- Carbide tips are optional
- Rotor cooling available for low melt point materials

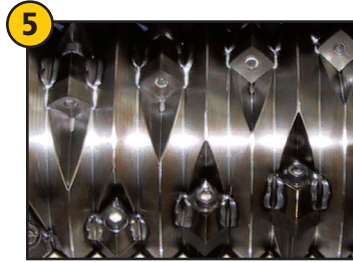

HYDRAULIC*

- Completely enclosed in machine
- Cylinders mounted on universal joints
- Cooling package available for 24-hour operations
- Heating package available for cold weather start-up

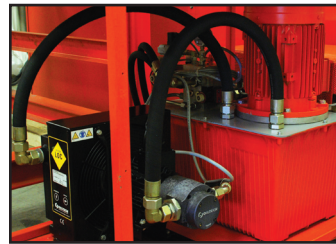

BEARINGS*

- Bearings with spatter ring
- Flange mounted
- Pillow block available

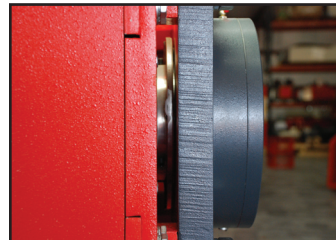

*not visible from this angle

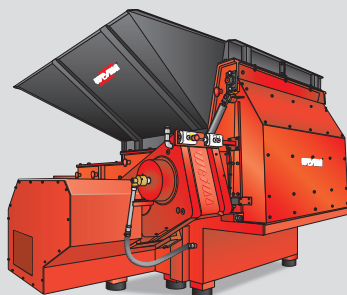

WL 15

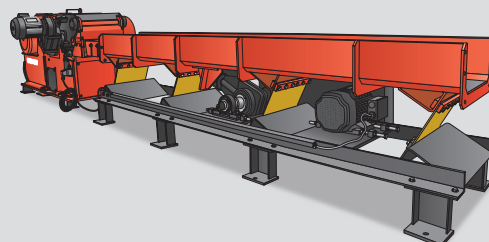

HORIZONTAL

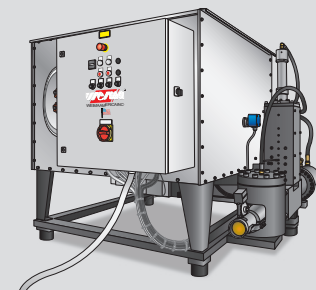

BRIQUETTE PRESS

Technical Data

WL(K) 10 – WL(K) 20

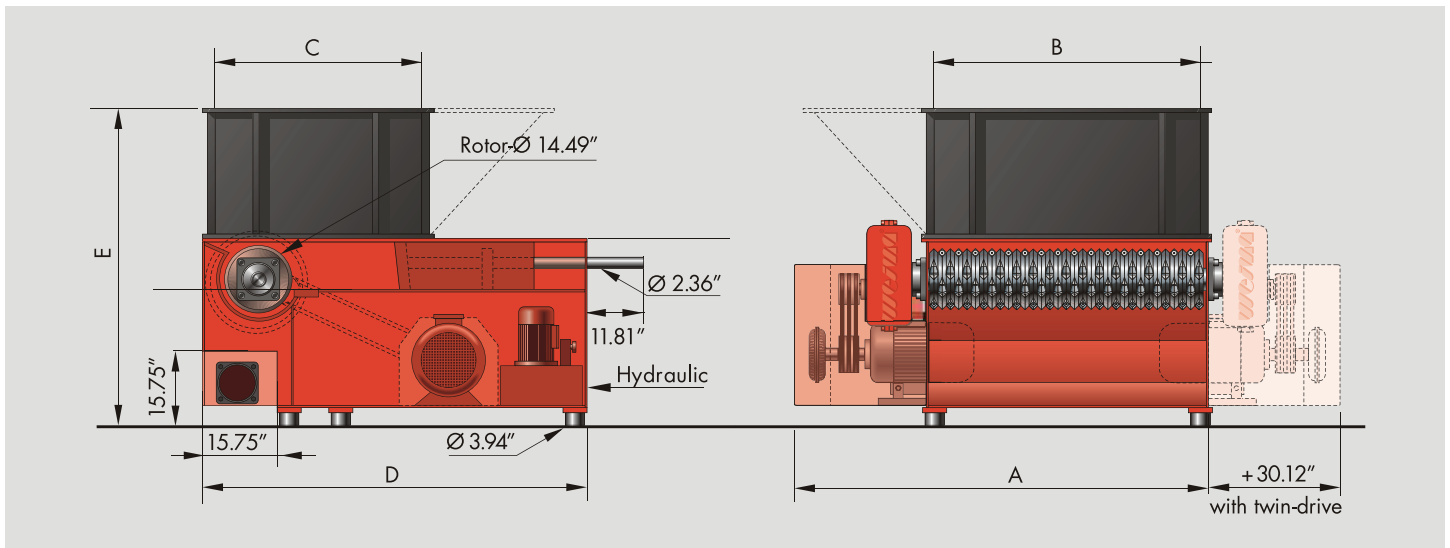

	WL(K) 10	WL(K) 12	WL(K) 13	WL(K) 14	WL(K) 15	WL(K) 18	WL(K) 20
Hopper opening (Inch):	39.4 x 47.2	47.2 x 47.2	51.2 x 47.2	59.1 x 47.2	59.1 x 59.1	70.9 x 59.1	78.7 x 59.1
(mm):	1,000 x 1,200	1,200 x 1,200	1,300 x 1,200	1,500 x 1,200	1,500 x 1,500	1,800 x 1,500	2,000 x 1,500
Hopper vol. (yd³/m³):	1.7/1.3	2.0/1.5	2.1/1.5	2.5/1.9	3.0/2.3	3.7/2.8	3.9/3.0
Throughput (kg/h):	The throughput rate depends on material composition and screen size						
Rotor diameter (In./mm):	14.5/368	14.5/368	14.5/368	14.5/368	14.5/368	14.5/368	14.5/368
Rotor speed (rpm):	60 – 120	60 – 120	60 – 120	60 – 120	60 – 120	60 – 120	60 – 120
Power (hp):	50/60	60/75	60/75	75/100/120	75/100/120	100/120/150	100/120/150
(kW):	37/45	45/55	45/55	55/75/90	55/75/90	55/75/90	75/90
Rotor knives:	52	64	68	82	82	100	112
Screen size (In./mm):	3/8 – 4" / 10 – 100mm (For all models)						
Connection-Ø (In./mm):	8/200	8/200	8/200	10/250	10/250	10/250	10/250
Weight approx. (lbs/kg):	7,700/3,500	8,800/4,000	9,900/4,500	11,000/5,000	12,300/5,600	16,000/7,300	17,900/8,100
Size A (Inch/mm):	70.9/1,800	78.7/2,000	82.7/2,100	90.6/2,300	90.6/2,300	102.4/2,600	118.1/3,000
Size B (Inch/mm):	39.4/1,000	47.2/1,200	51.2/1,300	59.1/1,500	59.1/1,500	70.9/1,800	78.7/2,000
Size C (Inch/mm):	47.2/1,200	47.2/1,200	47.2/1,200	47.2/1,200	59.1/1,500	59.1/1,500	59.1/1,500
Size D (Inch/mm):	82.7/2,100	82.7/2,100	82.7/2,100	82.7/2,100	106.3/2,700	106.3/2,700	106.3/2,700
Size E (Inch/mm):	67.7/1,720	67.7/1,720	67.7/1,720	67.7/1,720	67.7/1,900	74.8/1,900	74.8/1,900

Demonstrations and tests with your materials are possible in our facility by appointment.

WEIMA America, Inc.

3678 Centre Circle, Fort Mill, SC 29715

Phone: 803-802-7170 // Fax: 803-802-7098

www.weimaamerica.com // info@weimaamerica.com

With locations in:

Ilfeld, Germany // Ternberg, Austria // Northants, Great Britain // La Ferté s. Jouarre, France // Harjumaa, Estonia