

Instruction Manual

MODEL G-A MODEL GK-A



SAFETY



OPERATION



MAINTENANCE



PARTS

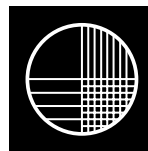

URSCHEL
LABORATORIES INCORPORATED

The following revisions apply to this manual:

This manual represents the machine as it is currently manufactured. If your machine contains parts not shown in this manual, contact Urschel Laboratories, Inc., Customer Service Department.

- Page 14 **Specifications:** In January 1998 the United States Department of Agriculture discontinued its Equipment Acceptance Program in lieu of a processor based Hazard Analysis & Critical Control Point system. By ruling, all U.S.D.A., Meat & Poultry Division approvals of equipment, including those of Urschel® machines, have been eliminated.
- Page 15 Under OPERATING PRINCIPLE, the second sentence should read: Centrifugal force holds the product against the inside of the slice case as the impeller **paddles** carry the product past the slicing knife.
- Page 29, 45 & 47 The **lubricant** recommended for this machine has changed. See pages A3 through A5.
- Page 47 Under step 10, add **Tighten screws to 35 in/lb.**
- Page 58 **The following paragraph is part of the Electrical Assembly Inspection:**

Safety switches: Check sensors, actuators and cords for damage. *Switches should be replaced if any defect or damage is detected.* Check switch alignment. Actuator must be within 1/16" (1.6 mm) of sensor to complete safety switch circuit.
- Page 59 "NOTE" at end of page pertaining to amplifier exchange program is now deleted. New information for **63737 Amplifier Warranty:** Effective July 1, 2002, Urschel Laboratories no longer offers an exchange program for the 63737 amplifiers. Beginning July 1, 2002, there will be a warranty on the amplifier of two years from the date the unit is shipped to the customer. Failed warranty units need to be returned to Urschel Laboratories to receive a replacement.
- Page 66 Delete **Machine Maintenance (English)** and the related part no's. under **FORMAT.**
- Page 69 Part number 11045 Grease Cartridge, Haynes® Lubri-Film, is replaced by part number **11915 Grease, Ultra Performance FDA, cartridge.**

(continued)

- Page 74 & 75 **Slicing Unit** - Items 2 and 3 are installed into Item 15 slice gate clamp from the bottom.
- Page 85 **Please note the following changes to the Circular knife spindle assembly chart:**
- The 1/8" and 5/32" size of cut should have the †† notation applied.**
 Also, **Item 11, Stripper Plate No.** for 1/8" slot spacing is now **13710**
 and for 5/32" slot spacing is now **13711.**
 § Nickel plated manganese aluminum bronze is no longer applicable.
- Pages 86–95 This **Electrical Assembly** information is replaced by pages A8–A14 in this addendum. Repair parts are available on past electrical assemblies except as noted below.
- Part No. 12774 IEC Disconnect Switch Handle is no longer available; replace with: **21241 IEC Disconnect Switch Handle.** A retrofit kit may be necessary. Contact the factory.
- Part No. 12775 IEC Disconnect Switch is no longer available; replace with: **12942 IEC Disconnect Switch**
- Page 97 Items 2–17 - Stearns 55400 Brake Assembly information is replaced by the attached **Stearns 56200 Brake Assembly** information, pages A6 & A7 in this addendum. While these brakes are no longer available, repair parts can be purchased. Contact Urschel Laboratories if a complete brake assembly replacement is necessary.
- Page 100 Add **5/16"** to chart under Circular Knife Size of Cut and **Spring Plate 13712** for this size.
- Page 101 **Optional Parts** - the heading in the first column of the chart on this page- which currently reads: Circular Knife - Size of Cut, should read: **Slice Thickness.**
- The attached page A15 has been added to show conversion parts for 5/8 and 3/4" cuts.

attachments

IMPORTANT NOTICE!

CHANGE OF RECOMMENDED LUBRICANT

ROYAL PURPLE Ultra-Performance Clear FDA™ Synthetic Grease No. 0
for use on
Models G-A, GK-A, H-A, HX-A, OC, OC-45, OV, Q, TRS 2000 & TRS 2500

Due to recent advances in synthetic grease technology and after extensive testing, Urschel Engineering is now recommending Royal Purple Ultra-Performance Clear FDA™ synthetic grease, No. 0 (NLGI grade 0) on the machine models listed above. Royal Purple Ultra-Performance Clear FDA™ synthetic grease has proven to be an effective lubricant for both wet and extended run applications; see photos below. All new machines and replaceable components such as spindle bearing assemblies and crosscut knife assemblies for the stated models will be supplied with the Royal Purple grease. In addition, to extend the life of the machines and components already in operation, Urschel Laboratories strongly recommends that you upgrade your existing Model G-A, GK-A, H-A, HX-A, OC, OC-45, OV, Q, TRS 2000 and TRS 2500 machines to Royal Purple Ultra-Performance Clear FDA™ grease as well.

Royal Purple Ultra-Performance Clear FDA™ synthetic grease can be introduced into existing machinery by greasing the lubrication points until the old lubricant is purged from the machine. Refer to machine manual for lubrication points and schedules for your particular machine.

Royal Purple Ultra-Performance Clear FDA™ synthetic grease, No. 0 (NLGI grade 0) can be purchased from Urschel Laboratories in 14.5 ounce cartridges, part #11915.

Royal Purple Ultra-Performance Clear FDA™ synthetic grease, No. 0 meets the USDA H-1 classification for incidental contact in federally inspected meat and poultry plants. See separate spec sheet.

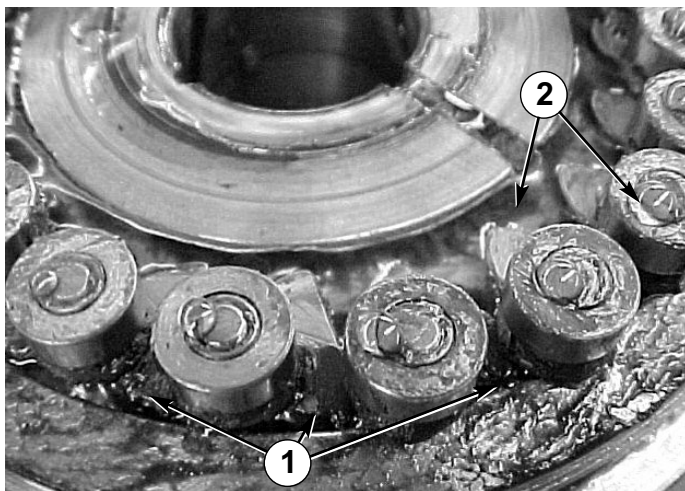

Figure 1 — Wet Test, G-A Crosscut Spindle. Royal Purple Ultra-Performance Clear FDA grease run time of 8 hours. Internal parts remain well lubricated. (1) Grease pockets, (2) Water.

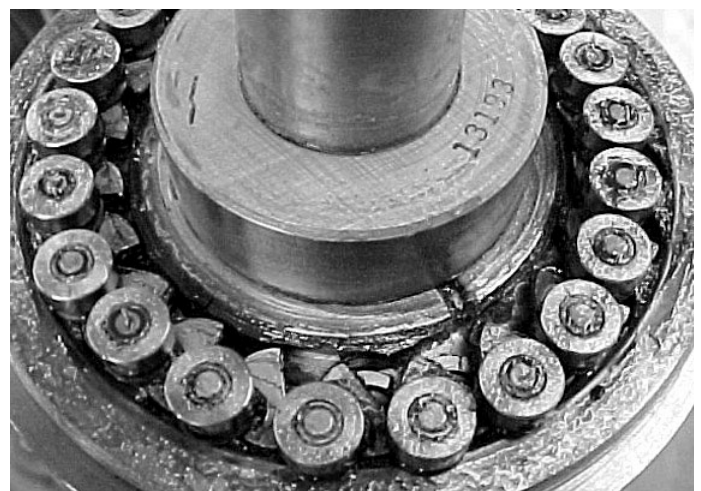

Figure 2 — Dry Test, G-A Crosscut Spindle. Royal Purple Ultra-Performance Clear FDA grease run time of 300 hours. Internal parts remain well lubricated.

©Urschel is a registered trademark of Urschel Laboratories, Inc.

™Ultra-Performance Clear FDA is a registered trademark of Royal Purple, Inc.



URSCHEL
LABORATORIES INCORPORATED
2503 Calumet Avenue
P.O. Box 2200
Valparaiso, Indiana 46384-2200 U.S.A.
219/464-4811 Fax: 219/462-3879



Ultra-Performance Clear FDATM Synthetic Grease Urschel Laboratories Part No. 11915

Ultra-Performance Clear FDA Synthetic Grease is a clean, clear, colorless, nonstaining, nondrying, biodegradable aluminum complex H-1 grease authorized by USDA for use in Federally Inspected meat and poultry plants. It meets or exceeds the requirements of CFR, Title 21, Paragraph 178.3750 of FDA Regulations and is specifically designed for use in the food processing industry where it may have incidental contact with food. Ultra-Performance Clear FDA Synthetic Grease is extremely water resistant even after frequent wash downs. Polymer additives plus Teflon* provide superior adhesive/cohesive strength to lower friction and protect against high shock loads.

Ultra-Performance Clear FDA Synthetic Grease contains a bacteriostatic agent to retard bacterial and fungus growth. Antiwear additives protect against metal to metal contact providing longer machine life and increased productivity. Ultra-Performance Clear FDA Synthetic Grease can be used in applications from 0° - 400°F (-18° - 204°C). It is recommended for lubrication of roller, needle, ball, journal, and sliding bearings in the food processing and handling industries.

Ultra-Performance Clear FDA's benefits are:

- Aluminum Complex Grease Base: an adhesive, non-drip base possessing superior shear stability, water resistance and high temperature performance.
- Multi-Temperature: synthetic molecules allow good low temperature pumpability and high temperature stability. Suitable for centralized pressure systems.
- Bacteriostatic Agent: retards bacterial and fungus growth.
- Increases Food Machinery Life: contains synthetic ingredients, anti-wear additives plus Teflon*.
- Biodegradable
- Prevents Rust & Corrosion
- Nonstaining / Nontoxic

*E.I. Dupont Company Registered Trademark

Ultra-Performance Clear FDA™

Synthetic Grease

Urschel Laboratories Part No. 11915

ASTM	Test	Typical Properties*
----	NLGI Grade	0
----	Texture	Buttery
----	Thickener type (soap base)	Aluminum Complex
----	Color	Clear to Translucent Light Amber
----	Base Oil	Semi-Synthetic
----	USDA H-1	Yes
D-217	Cone Penetration, mm Worked	365 500 (260)
D-2265	Dropping Point, °F (°C)	
D-2161	Base Oil Viscosity, cSt @ 40°C	126 1A
D-4048	Copper Strip Corrosion	
D-2266	Four-Ball Wear Test, scar width, mm, 40 kg. 1200 rpm, 165°F, 1 hr.	0.70 Pass
D-1743	Rust Resistance	
----	Low Temperature Pumpability °F (°C)	15 (-9)

*Properties are typical and may vary.

PARTS

10 LB-FT Stearns 56200 Brake Assembly

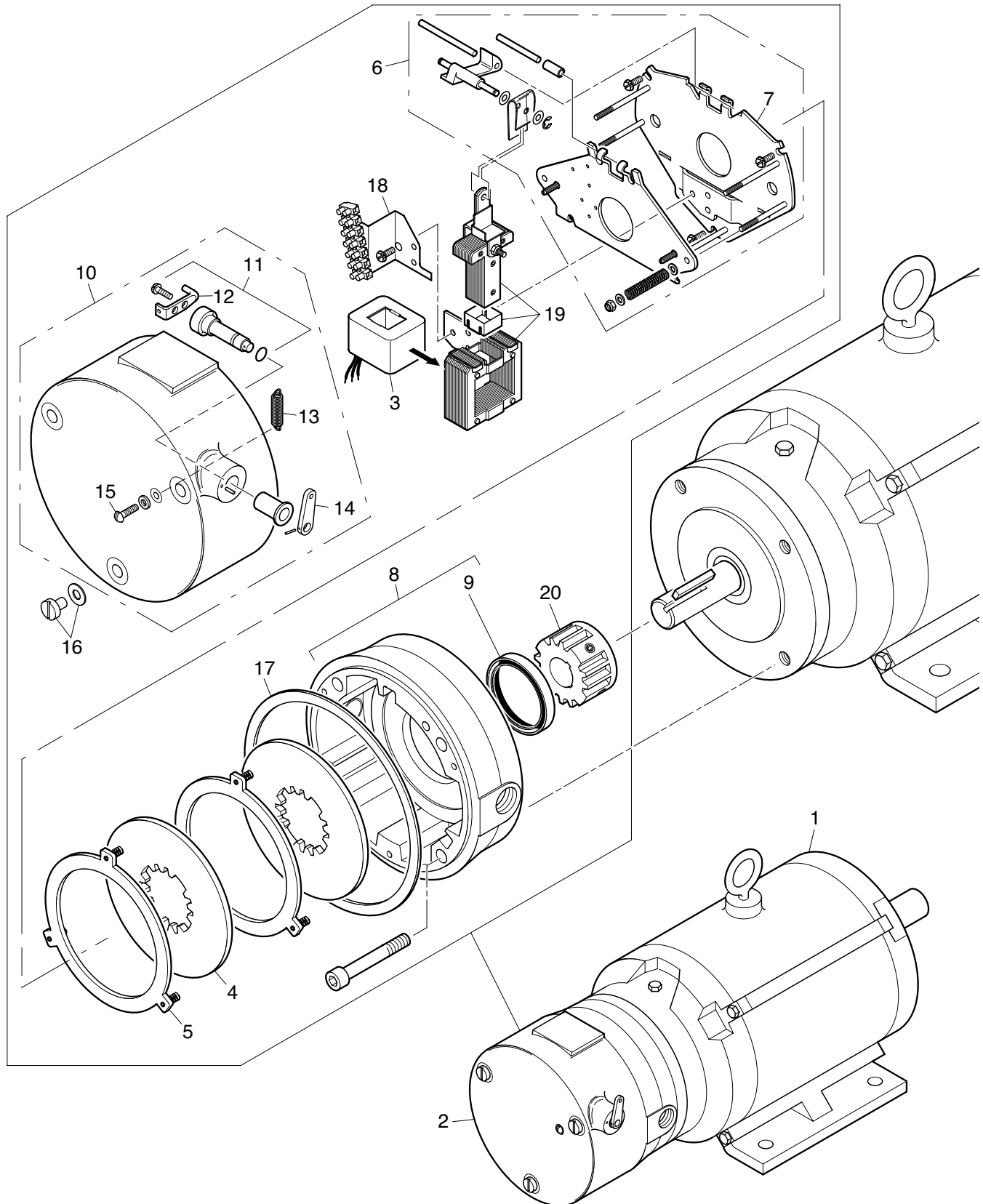

PARTS

10 LB-FT Stearns 56200 Brake Assembly

ITEM NO.	PART NO.	DESCRIPTION	QTY.
1	*	Motor, with brake, (includes item 2)	1
2	12897	Brake Assembly, 10 pound foot with 110 volt coil, 56200, use with VFD electrical assembly, (includes items 3-20)	1
	12898	Brake Assembly, 10 pound foot with 220 volt coil, 56200, use with across the line electrical assemblies, (includes items 3-20)	1
	12899	Brake Assembly, 10 pound foot with 575 volt coil, 56200, use with across the line electrical assemblies, (includes items 3-20)	1
3	12884	K4 Solenoid Coil, 110-120 volts	1
	12885	K4 Solenoid Coil, 200-240 volts	1
	12886	K4 Solenoid Coil, 575 volts, (for use in Canada)	1
4	12890	Friction Disc	2
5	12891	Stationary Disc Kit	1
6	12892	Support Plate Assembly, 10 pound foot, (includes item 7)	1
7	12903	Support Plate and Spring Stud Assembly	1
8	12893	Endplate and Seal Assembly, (includes item 9)	1
9	12906	Seal for Endplate	1
10	12894	Housing and Release Assembly, (includes items 11-15)	1
11	12910	Manual Release Assembly, (includes items 12-14)	1
12	12907	Release Lever	1
13	12908	Spring for Release Lever	1
14	12913	Handle, manual release, s.s.	1
15	10191	Round Head Machine Screw, 10-24 x 3/4", s.s.	1
16	12911	Housing Nuts and Gaskets	3
17	12905	Gasket, housing and endplate	1
18	12909	Terminal Kit	1
19	12904	Plunger, Link and Frame Assembly	1
20	12895	Hub and Set Screw Assembly	1

* Consult the factory.

PARTS

Electrical Assembly (NEMA)

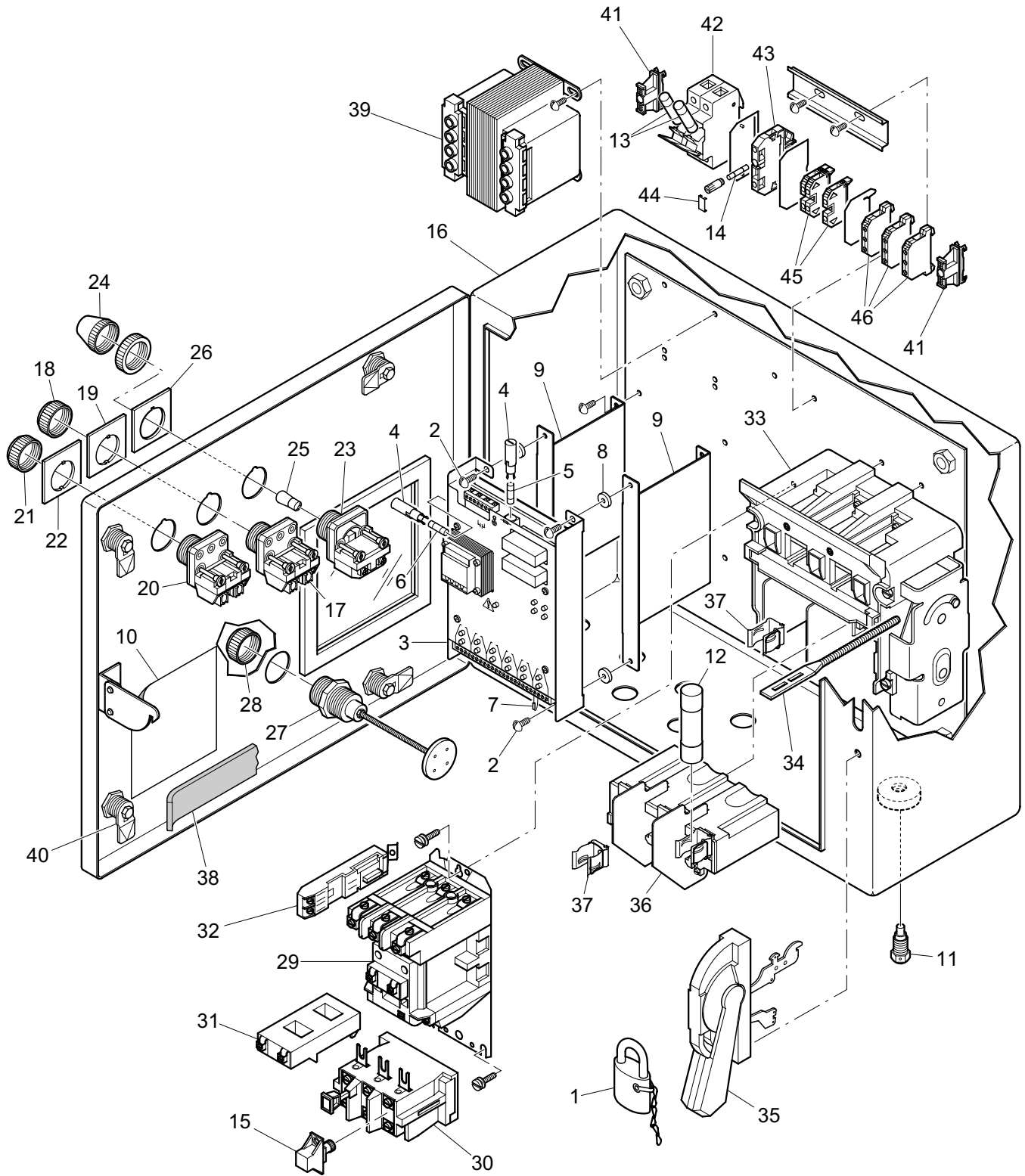

PARTS

Electrical Assembly (NEMA)

ITEM NO.	PART NO.	DESCRIPTION	QTY.
—	13726	Electrical Assembly, 200-240/460 volt, (includes items 1–15).	1
—	13728	Electrical Assembly, 575 volt, (includes items 1-15).	1
1	13408	Padlock, with chain.	1
2	10625	Round Head Machine Screw, w/washer, 10-32 x 1/2"	4
3	63737	Amplifier, (includes items 4–7)	1
4	13673	Adapter, fuse	2
5	13671	Fuse, .630 amp.	1
6	13672	Fuse, .125 amp.	1
7	63755	Resistor, 22 kOhm.	2
8	12633	Rubber Washer, 3/16 x 5/8 x 1/8" thick.	4
9	*	Amplifier Bracket	2
10	13749	Wiring Diagram.	1
11	11593	Breather/Drain, 1/4"	1
12	**	Fuse, FU1, (class J)	3
13	**	Fuse, FU2, (primary)	2
	12691	Fuse, FU2, (primary), .60 amp, (575 volt only).	2
14	21285	Fuse, FU3, (secondary), 1.0 amp., (all voltages)	1
15	**	Heater Element.	3
16	13722	Combination Starter, size "1" for 200-240/460 volt (includes items 17–46)	1
	13727	Combination Starter, size "1" for 575 volt (includes items 17–46)	1
17	13449	Push Button, start (includes item 18)	1
18	60218	Rubber Boot, start.	1
19	12605	Legend Plate, I for start.	1
20	13450	Push Button, stop (includes item 21)	1
21	60219	Rubber Boot, stop.	1
22	12606	Legend Plate, O for stop	1
23	12597	Pilot Light, (includes items 24 & 25).	1
24	12598	Lens, Pilot Light	1
25	12599	Bulb, pilot light	1
26	12600	Plate, blank grey, (pilot light)	1
27	12603	Reset Button, (includes item 28)	1
28	12604	Rubber Boot, reset	1
29	63281	Starter, size "1", (includes items 30–32).	1
30	12667	Overload Relay	1
31	13548	Operating Coil, for size 0 & 1 starter.	1
32	63579	Auxiliary Contact, normally open	1
33	13604	Disconnect, 30 amp.	1
34	63384	Connecting Rod	1
35	63383	Operating Handle	1
36	13605	Fuse Trailer Block, (includes item 37)	1
37	13381	Fuse Clip Kit, (set of 6)	1
38	*	Door Gasket, (fitting and adhesive required)	1
39	21267	Control Circuit Transformer, (200-460 volt only)	1
	21268	Control Circuit Transformer, 75VA, (575 volt only)	1
40	21270	Quarter Turn Latch Assembly, (Industrial Enclosures).	4
	21271	Quarter Turn Latch Assembly, (Hoffman Enclosures)	4
41	12751	End Anchor, IEC	2
42	12930	Modular Fuse Holder, 2 pole	1
43	12763	Fuse Terminal, 5 x 20 mm, IEC, (includes item 44)	1
44	12781	Transparent Cover	1
45	12760	Terminal, IEC	3
46	12750	Earthing Terminal, IEC.	3

* Consult the factory.

** See charts on page A14.

Electrical assemblies also include safety switches and related parts; see pages A12 & A13 in this addendum.

PARTS

Electrical Assembly (CE Compliant)

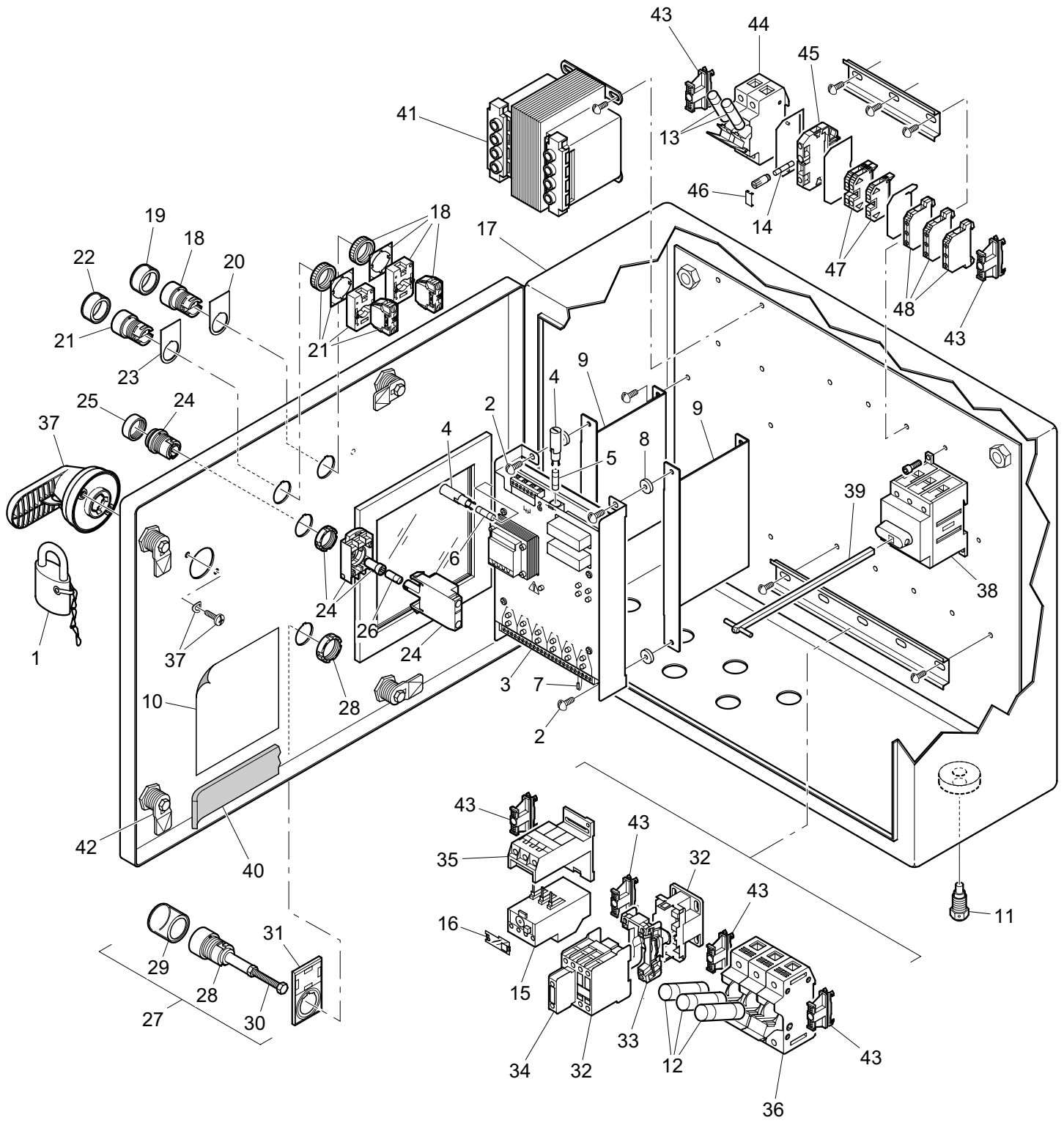

PARTS

Electrical Assembly (CE Compliant)

ITEM NO.	PART NO.	DESCRIPTION	QTY.
—	13730	Electrical Assembly, IEC, 380-415 volts, (includes items 1–16)	1
—	13732	Electrical Assembly, IEC, 200-240 volts, (includes items 1–16)	1
1	13408	Padlock, with chain.	1
2	10625	Round Head Machine Screw, w/washer, 10-32 x 1/2"	4
3	63737	Amplifier, (includes items 4–7)	1
4	13673	Adapter, fuse	2
5	13671	Fuse, .630 amp.	1
6	13672	Fuse, .125 amp.	1
7	63755	Resistor, 22 kOhm.	2
8	12633	Rubber Washer, 3/16 x 5/8 x 1/8" thick.	4
9	*	Amplifier Bracket	2
10	13724	Wiring Diagram.	1
11	11593	Breather/Drain, 1/4"	1
12	**	Fuse, FU1, (class J)	3
13	**	Fuse, FU2, (primary)	2
14	12923	Fuse, FU3, (secondary), .50 amp.	1
15	**	Overload Relay, (use with item 35 Overload Base Adapter)	1
16	12871	Transparent Cover For Adjustment Dial	1
17	13725	Electrical Enclosure, IEC, 22 amp, 380-415 volts, (includes items 18–48)	1
	13731	Electrical Enclosure, IEC, 22 amp, 200-240 volts, (includes items 18–48)	1
18	12975	Start Button Assembly, (includes item 19)	1
19	12977	Protective Cap, flush head, IEC	1
20	12978	Name Plate, (I) start, IEC.	1
21	12976	Stop Button Assembly, (includes item 22)	1
22	12977	Protective Cap, extended head, IEC	1
23	12979	Name Plate, (O) stop, IEC.	1
24	12757	Pilot Light, IEC, (includes items 25 & 26)	1
25	12758	Pilot Light Lens, IEC.	1
26	12599	Bulb, pilot light, IEC	1
27	12747	Reset Button Assembly, IEC, (includes item 28–30)	1
28	12744	Reset Button, IEC.	1
29	12748	Protective Cap, flush head, IEC	1
30	12745	Reset Extender, IEC	1
31	12746	Reset Insert With Holder	1
32	12753	Contact, 22 A., IEC (includes items 33 & 34)	1
33	12754	Coil, 110/120 volts, 50/60 Hertz, IEC	1
34	12755	Front-Mount Auxilliary Contact, normally open.	1
35	13677	Overload Base Adapter	1
36	12973	Modular Fuse Holder, 3 pole	1
37	21241	IEC Disconnect Switch Handle	1
38	12942	IEC Disconnect Switch.	1
39	12779	IEC Extended Shaft, 6.7" long	1
40	*	Door Gasket, (fitting and adhesive required)	1
41	12928	Control Circuit Transformer, (380-415 volts).	1
	12927	Control Circuit Transformer, (200-240 volts).	1
42	21270	Quarter Turn Latch Assembly, (Industrial Enclosures).	4
	21271	Quarter Turn Latch Assembly, (Hoffman Enclosures)	4
43	12751	End Anchor, IEC	6
44	12930	Modular Fuse Holder, 2 pole	1
45	12763	Fuse Terminal, 5 x 20 mm, IEC, (includes item 46)	1
46	12781	Transparent Cover	1
47	12760	Terminal, IEC	3
48	12750	Earthing Terminal, IEC.	3

* Consult the factory.

** See charts on page A14.

Electrical assemblies also include safety switches and related parts; see pages A12 & A13 in this addendum.

PARTS

Electrical Assembly (switches)

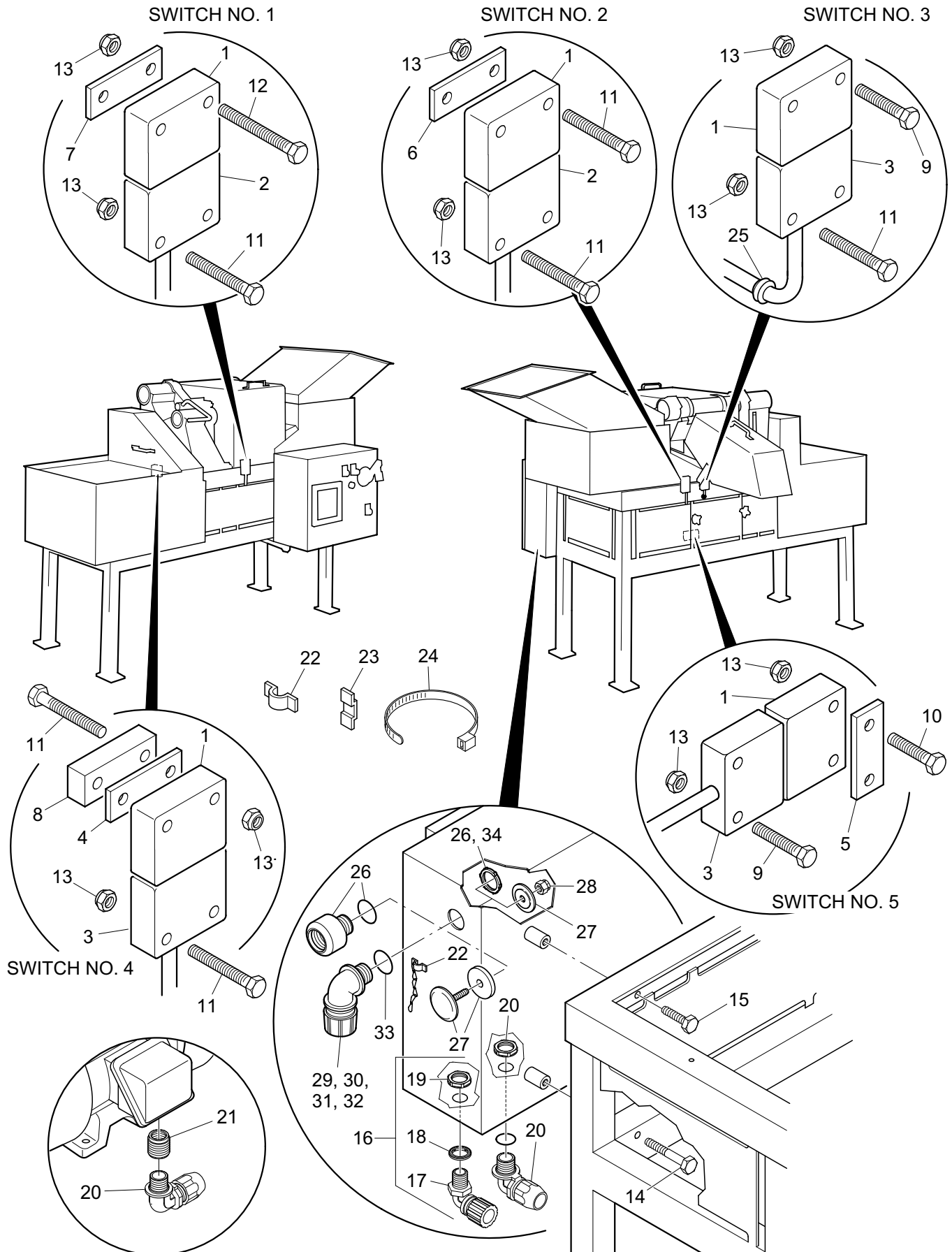

PARTS

Electrical Assembly (switches)

Electrical assemblies include the following items 1-25.

ITEM NO.	PART NO.	DESCRIPTION	QTY.
1	63741	Actuator	5
2	63738	Sensor, 6' lead	2
3	63739	Sensor, 12' lead.	3
4	12799	Spacer, 1/16" thick	1
5	12801	Spacer, 1/8" thick	1
6	12803	Spacer, 1/4" thick	1
7	12805	Spacer, 3/8" thick	1
8	12807	Spacer, 1/2" thick	1
9	10233	Hex Head Cap Screw, 10-24 x 1", s.s.	4
10	10351	Hex Head Cap Screw, 10-24 x 7/8", s.s.	2
11	10348	Hex Head Cap Screw, 10-24 x 1-1/4", s.s.	12
12	10349	Hex Head Cap Screw, 10-24 x 1-1/2", s.s.	2
13	10231	Hex Nut, 10-24, s.s., locking	20
14	10053	Hex Head Cap Screw, 5/16-18 x 2-1/2", s.s.	2
15	10044	Hex Head Cap Screw, 5/16-18 x 5/8", s.s.	2
16	11548	Cord Connector, 90 degree, .250/.375, (includes items 17-19)	5
17	11609	Cord Connector, 90 degree, .250/.375.	1
18	11900	Seal Washer, 3/16 x 7/8 x 1-9/32"	1
19	11611	Lock Nut, 1/2"	1
20	11614	Conduit Connector, 1/2", 90 degree	2
21	11502	Reducing Bushing, 1/2 x 3/4"	1
22	13424	Clip, chain	1
23	13465	Clip, cable tie	23
24	11513	Cable Tie	26
25	45426	Grommet, rubber	1

THE FOLLOWING ITEMS ARE NOT INCLUDED WITH THE ELECTRICAL ASSEMBLY. CHOOSE ONE FOR USE AT THE POWER SOURCE ENTRY POINT.

26	11582	Conduit Hub, 1", (includes washer and lock nut)	1
27	11591	Hole Seal, 1-3/8"	1
28	10231	Hex Nut, 10-24, s.s., locking	1
—	11626	Cord Connector Assembly, 90 degree, .437/.562, (includes items 29, 33 & 34)	1
29	11625	Cord Connector, 90 degree, .437/.562	1
—	21370	Cord Connector Assembly, 90 degree, .62/.75, (includes items 30, 33 & 34)	1
30	21368	Cord Connector, 90 degree, .62/.75.	1
—	21371	Cord Connector Assembly, 90 degree, .75/.88, (includes items 31, 33 & 34)	1
31	21369	Cord Connector, 90 degree, .75/.88.	1
—	21372	Cord Connector Assembly, 90 degree, .88/1.0, (includes items 32, 33 & 34)	1
32	11972	Cord Connector, 90 degree, .88/1.0.	1
33	11966	Seal Washer, 3/16" x 1-5/16" x 1-3/4"	1
34	11624	Lock Nut	1

PARTS

Electrical Schematics

NEMA

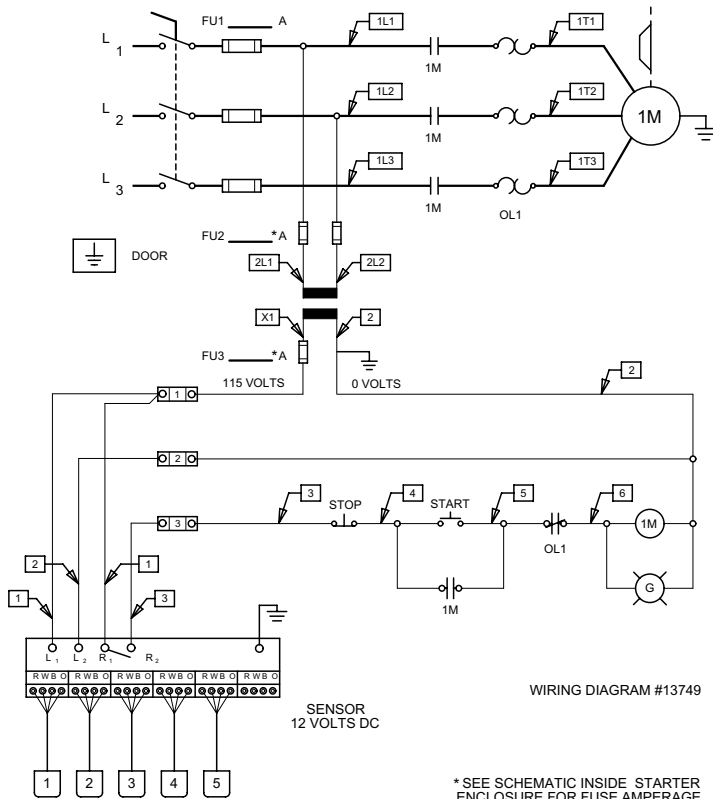

Use with 13749 & 13724 schematics.

MOTOR FULL LOAD AMPS	HEATERS	FUSE (FU1) CLASS J (AJT) FUSE AMPS
1.60 - 1.75	W33 12640	12785 3
1.76 - 1.93	W34 12680	12786 4
1.94 - 2.12	W35 12641	12786 4
2.13 - 2.33	W36 12642	12786 4
2.34 - 2.56	W37 12643	12787 5
2.57 - 2.81	W38 12580	12787 5
2.82 - 3.09	W39 12581	12787 5
3.10 - 3.40	W40 12582	12788 6
3.41 - 3.74	W41 12583	12788 6
3.75 - 4.11	W42 12584	12789 8
4.12 - 4.52	W43 12585	12789 8
4.53 - 4.97	W44 12586	12789 8
4.98 - 5.46	W45 12587	12790 10
5.47 - 6.01	W46 12588	12790 10
6.02 - 6.60	W47 12589	12791 12

Use with 13724 schematic.

OVERLOAD RELAY BLOCK	
MOTOR FULL LOAD AMPS	PART NO.
.25 - .41	13694
.40 - .65	13695
.65 - .99	13696
1.00 - 1.29	13698
1.30 - 1.71	13699
1.72 - 1.79	13699
1.80 - 2.49	13679
2.50 - 2.85	13680
2.86 - 3.42	13680
3.43 - 3.99	13680
4.00 - 4.57	13681
4.58 - 5.49	13681
5.50 - 5.71	13682
5.72 - 7.99	13682
8.00 - 8.57	13683
8.58 - 10.00	13683
10.01 - 11.42	13684
11.43 - 14.49	13684
14.50 - 17.49	13685
17.50 - 20.99	13686

Use with 13749 & 13724 schematics.

SWITCH LOCATIONS	
SWITCH NUMBER	LOCATION
1	CHIP CHUTE ENCLOSURE
2	FEED HOPPER
3	DISCHARGE CHUTE
4	MOTOR COVER
5	SIDE COVER

Use with 13749 schematic.

LOCATION	VOLTAGE	FUSE (FU2) PART NO.	AMPS
N. AMERICA	208 - 230	12697	1.50
	460	12692	.8
OUTSIDE N. AMERICA	200 - 208	12994	2.00
	220 - 240	12929	1.00
	380-415	12924	.50

CE Compliant

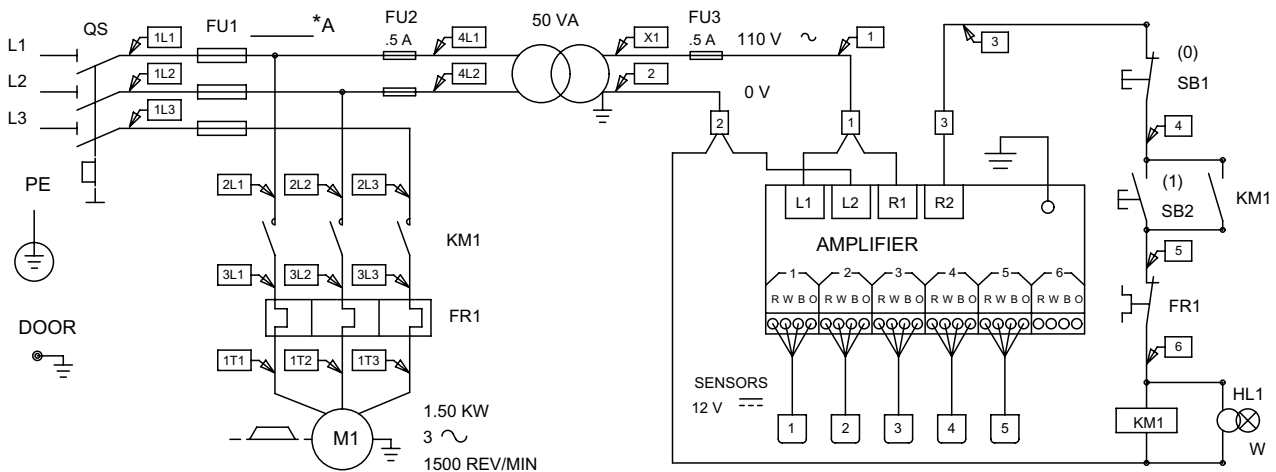

PARTS

Conversion Parts for 5/8" & 3/4" Cuts

The Models G-A and GK-A can be adapted to make true 3/4" x 3/4" x 3/4" (19.1 mm x 19.1 mm x 19.1 mm) or 5/8" x 5/8" x 5/8" (15.9 mm x 15.9 mm x 15.9 mm) cuts with the installation of the parts shown below.

When converting to these sizes of cuts, only the crosscut and circular knife spindles listed on pages 80-81 and 84-85 may be used. Contact Urschel Laboratories for information on specific applications and limitations.

ITEM NO.	PART NO.	DESCRIPTION	QTY.
1	13733	Knife, crosscut, straight, large cuts, (replaces 13144, item 1, page 80, see chart below)	*
	13750	Knife, crosscut, straight, large cuts, hard, (replaces 13144, item 1, page 80, see chart below)	*
2	13743	Stripper Plate, 5/8", 2.20" OD spacers, (replaces 13027, item 11, page 84) .	1
	13734	Stripper Plate, 3/8", 2.20" OD spacers, (replaces 13027, item 11, page 84) .	1
3	13747	Spacer, 5/8", 2.2" OD, .058 thick knife, (replaces 16121, item 6, page 84, see chart below)	**
	13735	Spacer, 3/4", 2.2" OD, .058 thick knife, (replaces 16109, item 6, page 84, see chart below)	**
4	13736	Shield, 2.20" OD spacers, (replaces 13440, item 10, page 70)	1

* See chart 1 below.

** See chart 2 below.

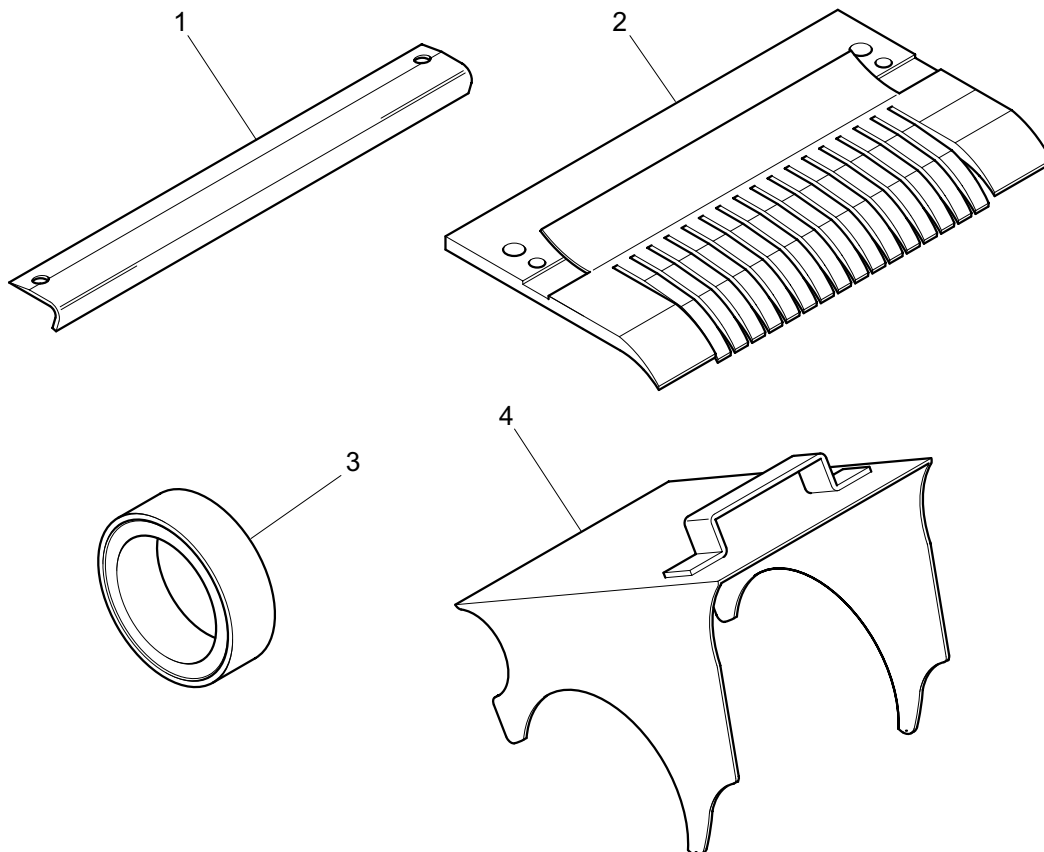

Chart 1

Size of Cut inch mm	Item 1 Knife	
	Number	Qty.
5/8 (15.9)	13733	10
	13750	10
3/4 (19.1)	13733	8
	13750	8

Chart 2

Size of Cut inch mm	Item 2 Stripper Plate		Item 3 Spacer
	No. & Slot Spacing	No. & Qty.	
5/8 (15.9)	13743	5/8"	13747 9
			16106*** 1
3/4 (19.1)	13734	3/8"	13735 8

*** Last spacer to be placed on the spindle.

This page intentionally left blank.

MODELS G-A & GK-A

Instruction Manual

1578 SEP 95
(supersedes 1222 APR 86 and 1221 APR 86)

Urschel Laboratories, Inc.
2503 Calumet Ave.
P.O. Box 2200
Valparaiso, Indiana 46384-2200 U.S.A.
219/464-4811 fax: 219/462-3879
e-mail: info@urschel.com
web site: <http://www.urschel.com>

With subsidiaries and sales offices in principal cities worldwide.

This instruction manual represents the machine as it is manufactured at time of publication and contains the most current information available at time of publication. Urschel Laboratories reserves the right to make changes at any time without notice. If your machine contains parts not shown, or if there are any questions regarding the safe operation of this machine, contact Urschel Laboratories.

COPYRIGHT© 2000 Urschel Laboratories, Inc., Valparaiso, Indiana. All rights reserved. No part of this manual may be reproduced or transmitted in any form or by any means, electronic or mechanical, including photocopying and recording, for any purpose without the express written permission of Urschel Laboratories, Inc.

® Urschel is a registered trademark of Urschel Laboratories, Inc.
® Haynes is a registered trademark of Haynes Manufacturing Co.

contents

FOREWORD	6
---------------------------	---



SAFETY

RULES FOR SAFE OPERATION	9
SAFETY SIGNS	10
PROTECTIVE DEVICES	12



OPERATION

GENERAL INFORMATION	14
Specifications, Product Limitations, Noise Emission	14
Applications, Operating Principle	15
Sizes of Cuts, Measuring Crinkle Cuts, Types of Cuts	16
Machine Shipment, Pre-Installation Plan, Location	18
Lifting the Machine	19
INSTALLATION	20
Electrical Power	20
SAFETY SWITCHES	22
Amplifier, Safety Switch Test	22
START-UP AND STOPPING	24
Pre-start Checklist, Start-up Procedure & Stopping Procedure	24
FEEDING PRODUCT	25
Feeding Method	25
MOTOR OVERLOAD OR JAM	26
Motor Overload, Correcting Machine Overload or Jam	26



MAINTENANCE

CLEANING	28
Importance of Daily Cleaning, Cleaning Agents & Daily Cleaning Procedures	28
LUBRICATION	29
Recommended Lubricant, Lubrication Points, Lubrication Schedule, Gear Lubrication, & Motor Lubrication	29

(continued)

contents

MAINTENANCE (continued)

COVERS AND GUARDS	30
Removal, Inspection, Installation	30
SLICING UNIT	32
Disassembly	32
Inspection, Reassembly	33
Adjustments	34
DICING UNIT	36
Disassembly	36
Inspection	37
Reassembly	38
Adjustments	39
CROSSCUT KNIFE SPINDLE ASSEMBLY	40
Operating Principle, Disassembly (all spindles)	40
Inspection	42
Repair Tolerance Charts	43
Reassembly	44
Bearing Block Replacement	48
Disassembly	49
Inspection	50
Reassembly	51
CIRCULAR KNIFE SPINDLE ASSEMBLY	53
Disassembly, Inspection	53
Reassembly	54
DRIVE TRAIN	55
Disassembly	55
Inspection, Reassembly	56
ELECTRICAL ASSEMBLY	58
Inspection	58
KNIFE CARE	60
Knife Care Guidelines, Sharpening Equipment, & Recommended Minimum Dimensions	60
Buffing	61
TROUBLESHOOTING	62

contents



PARTS

MAINTENANCE VIDEOTAPES	66
ORDERING INFORMATION	67
Ordering Parts, Returning Parts for Repair	67
TOOLS	68
FRAME, COVERS AND GUARDS	70
SLICING UNIT (G-A)	72
SLICING UNIT (GK-A)	74
DICING UNIT	76
DRIVE TRAIN	78
CROSSCUT KNIFE SPINDLE ASSEMBLY (7-16 KNIVES)	80
CROSSCUT KNIFE SPINDLE ASSEMBLY (22 KNIFE)	82
CIRCULAR KNIFE SPINDLE ASSEMBLY	84
ELECTRICAL ASSEMBLY (NEMA)	86
ELECTRICAL ASSEMBLY (IEC)	90
ELECTRICAL SCHEMATICS (NEMA)	94
ELECTRICAL SCHEMATICS (IEC)	95
MOTOR WITH DRIVE PARTS	96
MACHINE LABELS	98
OPTIONAL PARTS	100
DIMENSIONAL DRAWING	103

FOREWORD

You must learn and follow all the safety rules and operating principles set forth in this manual. This means:

1. Follow all warnings, cautions, and other safety messages in this manual and on the machine. Recognize the safety alert symbol , which indicates a potential personal safety hazard.
2. Never work beyond defined safety skills.
3. Insist on thorough and proper safety training.
4. Notify your supervisor of any machine condition which may create a hazard in its operation.
5. Notify Urschel Laboratories immediately of any accidents that have occurred on this machine.

If there are any questions regarding the safe operation of this machine, contact Urschel Laboratories.



THIS MANUAL MUST BE READ BY OR TO EACH PERSON BEFORE THAT PERSON OPERATES, CLEANS, REPAIRS, ADJUSTS, SUPERVISES THE OPERATION OF, OR USES THIS MACHINE IN ANY WAY.



ESTE MANUAL DEBE SER LEIDO POR O A CADA PERSONA ANTES DE COMENZAR A OPERAR, LIMPIAR, REPARAR, AJUSTAR, SUPERVISAR LA OPERACION DE, O UTILIZAR ESTA MAQUINA DE CUALQUIER MANERA.



CE MANUEL DOIT ETRE LU PAR, OU A, TOUTE PERSONNE AVANT QU'ELLE NE METTE EN ROUTE, NETTOIE, REPARE, REGLE, SUPERVISELE FONCTIONNEMENT OU UTILISE CETTE MACHINE, DE QUELQUE MANIERE QUE CE SOIT.



SAFETY



READ AND PRACTICE SAFETY RULES IN THIS MANUAL:

1. DANGER! This machine contains sharp knives and rotating parts. Never operate this machine if any guard or safety device has been removed or modified; doing so can result in serious injury or amputation.
2. When guards are removed, sharp edges and pinch points are exposed. Use extreme caution to avoid touching or striking these areas with your hands or body.
3. Always **disconnect and lock out the power source** before doing any work on this machine.
4. DANGER! Never put your hand or any foreign object into the feed opening or discharge area. Serious personal injury and/or damage to the machine may result.
5. NEVER attempt to assist the feeding or discharging of product with your hands.
6. Only qualified trained personnel should attempt to clean, adjust, repair or maintain the machine. Proper cleaning and maintenance procedures are found in the maintenance section of this manual.
7. Prior to operating the machine, the safety switches must be checked by qualified trained personnel. Complete information on checking safety switches is found in the operation section of this manual. If machine operates with any of the protective guards removed, this machine is not safe to operate. Call a qualified electrician immediately to locate and repair the fault.
8. Should the machine become overloaded or jammed, DO NOT attempt to correct the problem with the power source on. **Disconnect and lock out the power source**. Detailed instructions for correcting product jamming are found in the operation section of this manual and should be read and understood by all maintenance, service, or operation personnel.

SAFETY

Safety Signs



Safety signs and safety switches are placed on Urschel[®] machines to help you avoid personal injury. **They are there for your protection.** If your machine does not have these signs or switches, you must not operate the machine. Notify your supervisor and contact Urschel Laboratories, Inc. For the part numbers, languages and locations of safety signs, see “Machine Labels” in the parts section of this manual.



Figure 1 — Caution label

⚠ A caution label (Figure 1) is provided to remind you of safety rules which must be followed to avoid personal injury.



Figure 2 — Danger label, feed opening

⚠ Danger labels (Figure 2) are placed at or near the feed opening to warn you and anyone near the machine to keep hands and all other foreign objects away from the feed opening.



Figure 3 — Danger label, discharge chute

⚠ Danger labels (Figure 3) are placed on or near the discharge chute to warn you and anyone near the machine that this opening is an access to sharp rotating parts and pinch points which can cause serious injury. Never insert your hand, a tool, or any foreign object into the discharge chute.



Figure 4 — Danger label, removed guard

⚠ **Danger labels** (Figure 4) are visible when a protective cover or guard has been removed. This label warns you that the machine is unguarded and must not be restarted until all covers and guards are replaced.



Figure 5 — Danger and hazard alert labels

⚠ **A danger label and a hazard alert label** (Figure 5) are placed on the starter enclosure to warn you that this is a source of electrical hazard. The enclosure must be opened and serviced by a qualified electrician only and the installation must meet applicable codes. The number on the hazard alert label indicates the voltage requirements of the machine.

SAFETY

Protective Devices



Figure 6 — Safety switch



Figure 7 — Power disconnect/lockout switches

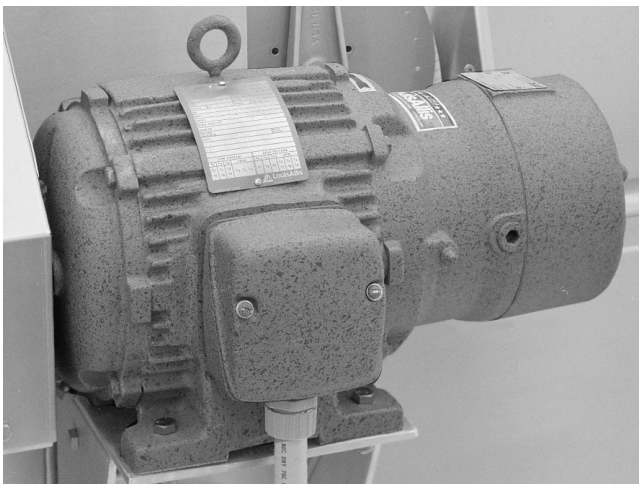

Figure 8 — Brake motor

⚠ **Safety switches** (Figure 6) are provided to prevent operation of the machine when a protective cover or guard has been removed. These switches must be checked before operating the machine and repaired or replaced if they do not work properly. Never rely solely on these safety switches. Always push the “O” (STOP) button then **disconnect and lock out the power source** before removing any part from the machine.

⚠ **Power disconnect/lockout switch** (Figure 7), located on the starter enclosure, will eliminate the danger of accidental start-up when locked in the “O” (OFF) position.

⚠ **A brake motor** (Figure 8) is provided to reduce “coasting” stops of potentially dangerous parts of the machine.

⚠ **Covers and guards** protect potentially dangerous machine areas. These covers and guards are of utmost importance to safe machine operation. **Never attempt to operate the machine with a cover or guard removed or serious injury may occur!**

Covers and guards, safety signs, safety switches, and brake motors are standard equipment on newly manufactured machines and are available for placement on older machines that may not have had them at the time of original manufacture. Contact Urschel Laboratories for complete information.

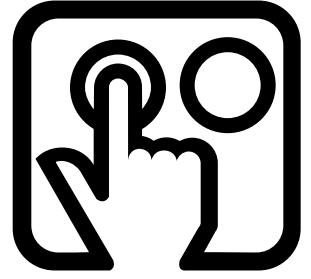

OPERATION

SPECIFICATIONS

The **Models G-A and GK-A** are equipped with **stainless steel*** product contact parts. Both machines are approved by the United States Department of Agriculture, Meat and Poultry Division.

⚠ WARNING: Do not modify this machine! Any modification or omission of parts could compromise the safety and sanitation of this machine and invalidate USDA approval.

Length:73.73" (1873 mm)
Width:45.94" (1167 mm)
Height:49.25" (1251 mm)
Net Weight:740 lbs. (336 kg)
Gross Weight Crated:950 lbs. (431 kg)
Gross Weight Export Box:1150lbs.(522 kg)
(See "Dimensional Drawing", page 103.)

Motor: 2 H.P., with brake, totally enclosed, non-ventilated. See motor specification plate and motor manufacturer's instructions for more information.

PRODUCT LIMITATIONS

MAXIMUM INPUT PRODUCT SIZE is 5-1/2" (140 mm) in any dimension. Precut product if necessary. Some products that are difficult to cut may require a smaller size of precut.

PROCESSING STICKY OR CANDIED PRODUCT will cause friction in the slicing unit.

PROCESSING FIBROUS PRODUCTS such as meats will result in gradual fiber build-up on the knife edges, causing crushing and incomplete cuts.

TRANSVERSE SLICES CANNOT BE PRODUCED from elongated products such as pickles, celery or rhubarb. Urschel Laboratories manufactures equipment better suited for these applications.

PRODUCTS WHICH ARE EXPLOSIVE or create a potentially explosive atmosphere should not be processed by this machine.

NOISE EMISSION

The amount of noise generated by this machine in use will vary depending on the type, condition and volume of product being cut, the size of cut and the acoustical characteristics of the room in which the machine is installed. A machine in good condition will register approximately 81 dB(A) in a free field over a reflecting plane when run without product and set to produce 9/32" (7 mm) dices. At a height of 63" (1600 mm) from the floor and 39.37" (1000 mm) from the machine, maximum sound position occurs at a point in front of the discharge chute on a standard height machine (Figure 9). Machines set for larger dicing or used without a crosscut spindle will generate less noise when measured under similar conditions.

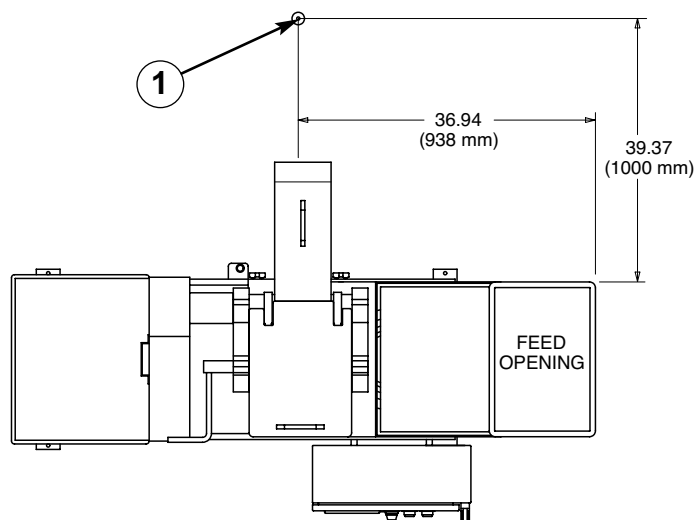

Figure 9 — Maximum sound position. (1) Measurement Position, 63" (1600 mm) from floor.

* Some parts may be made of different materials as noted.

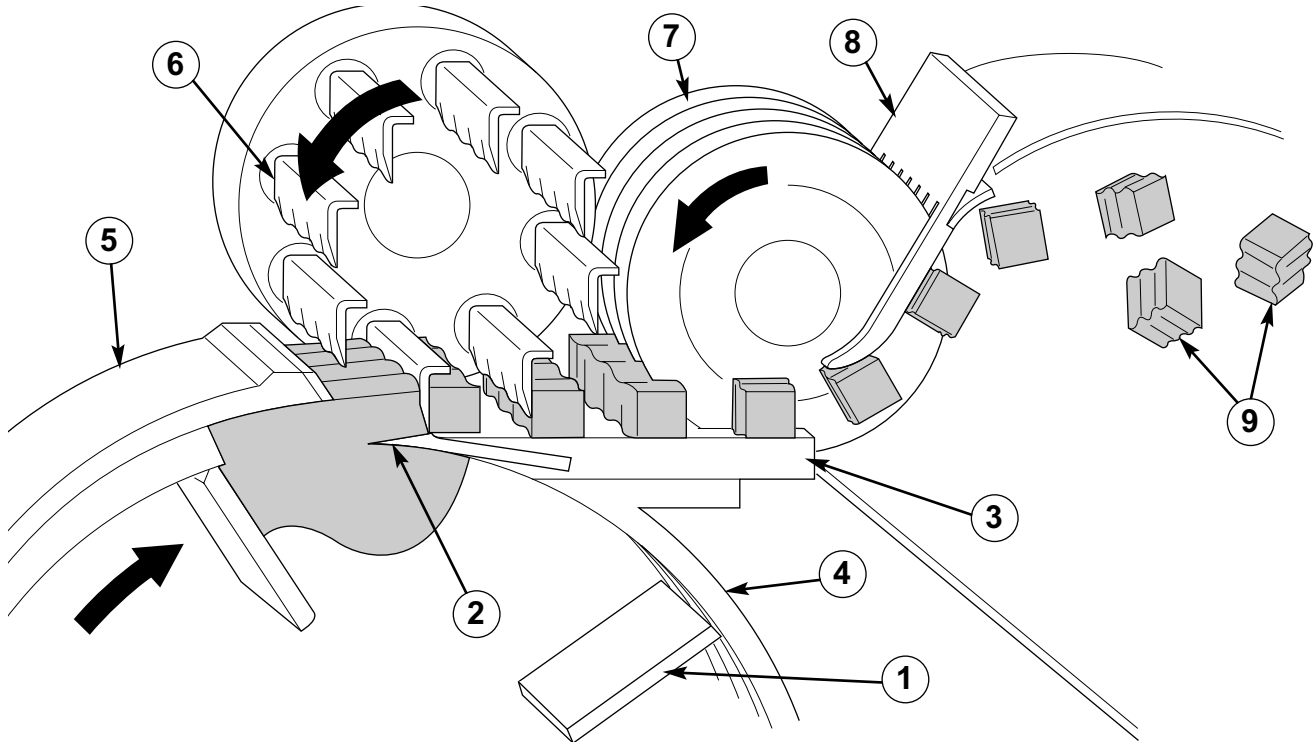

Figure 10 — Cutaway view of the dicing unit (Model GK-A). (1) Impeller (191 RPM), (2) Slicing Knife, (3) Slicing Knife Holder, (4) Slice Case, (5) Adjustable Case Gate, (6) Crosscut Knives (1395 RPM), (7) Circular Knives (1594 RPM), (8) Stripper Plate, (9) Product.

APPLICATIONS

The Model G-A will cut uniform dices, straight French fry strips, and slices from a variety of soft ripe fruits and brittle vegetables. A wide selection of interchangeable cutting parts enable the user to obtain gentle, clean cutting through a wide range of sizes at high production capacities. The machine features continuous operation for uninterrupted production, and simplified design for easy cleanup and maintenance.

The Model GK-A will cut crinkle slices, three dimensional cuts having four crinkle surfaces, and plain cuts from a variety of fruits and vegetables. This machine is especially suited to cutting crinkle French fry strips from potatoes.

OPERATING PRINCIPLE

Product is delivered to a feed hopper, then enters a rotating impeller (Figure 10). Centrifugal force holds the product against the inside of the slice case as the impeller blades carry the product past the slicing knife. An adjustable case gate at the top of the case allows the product to move outward across the edge of the slicing knife. The distance between the end of the case gate and the slicing knife edge determines the slice thickness.

As the slices emerge, crosscut knives move downward producing strips. Strips move without interruption across the top surface of the slicing knife holder into the circular knives where they are cut into cubes or other three-dimensional cuts of a selected size.

OPERATION

General Information

SIZES OF CUTS

Many sizes of cuts can be made using the various combinations of slice thicknesses, crosscut knife spindles and circular knife spacing.

Crosscut knives:

9/32–7/8" (7.1–22.2 mm). To change the size of this cut, different crosscut spindles must be installed. See "Crosscut Knife Spindle Assembly", pages 80–83.

Circular knives:

3/32–3" (2.4–76.2 mm). This dimension is changed by installing a different size spindle or by substituting a specified number of knives and spacers on your existing spindle. See "Circular Knife Spindle Assembly", pages 84 and 85.

Slice thickness:

1/16–3/4" (1.6–19.1 mm). Maximum is 13/32" (10.3 mm) when using crosscut spindles 7/16" (11.1 mm) or less and 17/32" (13.5 mm) when using crosscut spindles 1/2" (12.7 mm) or more. Slice thickness should not exceed the circular knife spacing.

NOTE: *Slice thickness exceeding these limits may result in crushing of product and damage to crosscut knives and spindle bearings.*

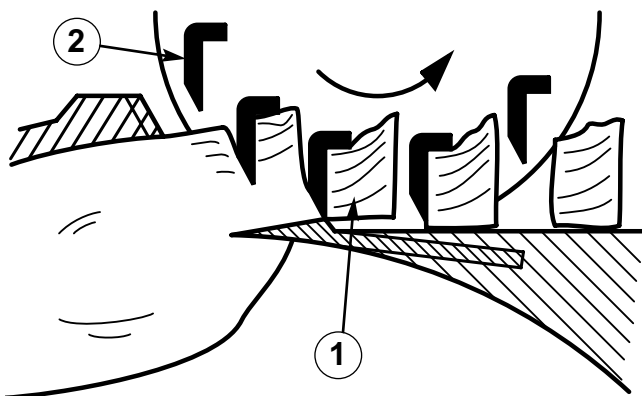

Figure 11 — Too great a slice thickness will result in the product being crushed by the crosscut knives. (1) Product, (2) Crosscut Knives.

ings (Figure 11). Slice thickness greater than 5/8" (15.9 mm) may require the use of reduced diameter circular knife spacers (see "Optional Parts", page 100).

To change the slice thickness see "Adjustments", page 35.

MEASURING CRINKLE CUTS

The depth of crinkles are approximately 1/16" (1.6 mm) with 3-1/3 crinkles per inch (25.4 mm). See Figure 12. The overall thickness is 1/16" (1.6 mm) greater than the nominal product thickness.

NOTE: *Dimensions of crinkle cuts given in this manual refer to the nominal product thickness.*

TYPES OF CUTS

Dicing:

A slicing knife, crosscut knife spindle and circular knife spindle are used for dicing (Figure 10, page 15). Changing the size of the cubes is done by using the required cutting spindles and adjusting the slice thickness.

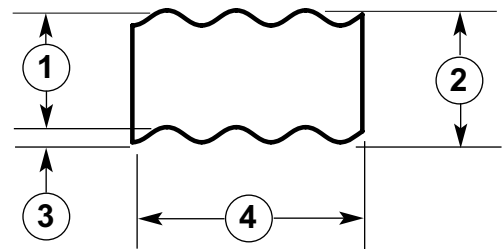

Figure 12 — Cross section of a crinkle cut. (1) Nominal Thickness, (2) Overall Thickness, (3) Depth of Crinkle—1/16" (1.6 mm), (4) 3-1/3 Crinkles per Inch (25.4 mm).

OPERATION

General Information

Slicing:

By removing the crosscut knife spindle, the circular knife spindle and the stripper plate, the machine can make slices thru the full range of slice thicknesses (Figure 13). To modify the machine for slicing only:

1. **Replace the standard slicing knife** with the knife designed for slicing only. See "Optional Parts", page 100.
2. **Replace the stripper plate** with the discharge chute support. See "Dicing Unit", page 77.
3. **Install the slice guide.** See "Optional Parts", page 100.

Strip cutting:

To make strip cuts, only the slicing knife and the crosscut knife spindle are used (Figure 14). The stripper plate must be replaced with the discharge chute support. See "Dicing Unit", page 77.

Julienne strips:

Use only a slicing knife and circular knife spindle (Figure 15).

1. **Replace the crosscut knife spindle** with the slice guide feed roll assembly to properly direct the slices to the circular knives. See "Optional Parts", page 101.
2. **Replace the standard slicing knife** with the knife designed for slicing only. See "Optional Parts", page 100.
3. **Replace standard slice guides** with slice guides designed for Julienne strips. See "Optional Parts", page 100.

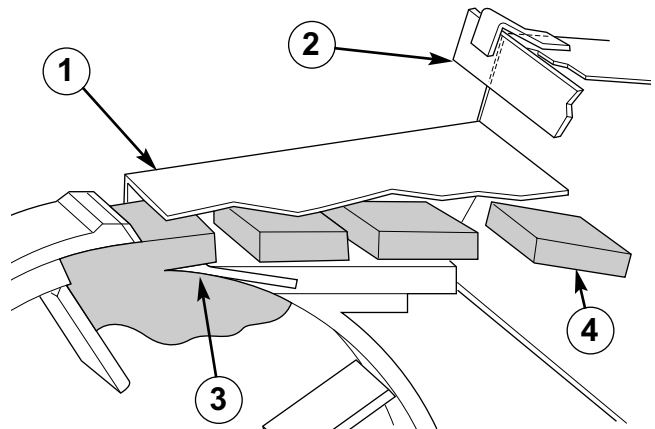

Figure 13 — The crosscut knife and circular knife spindles are removed to produce slices only. (1) Slice Guide, (2) Discharge Chute Support, (3) Knife for Slicing Only, (4) Slices.

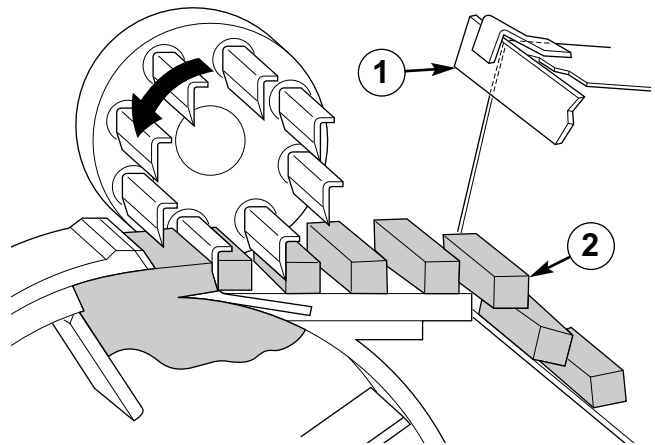

Figure 14 — Strip cuts are made using the slicing and crosscut knives only. (1) Discharge Chute Support, (2) Strips.

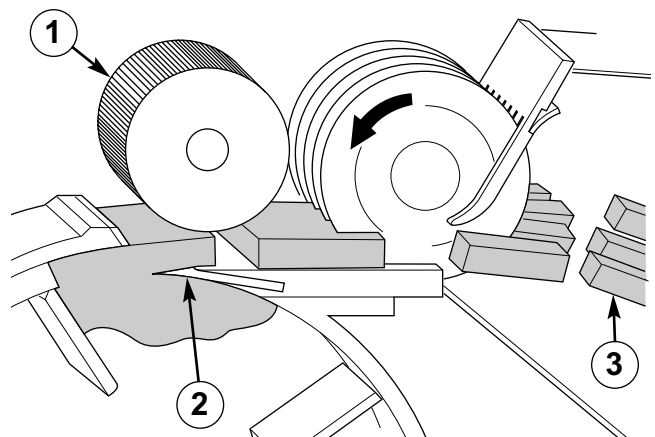

Figure 15 — Julienne strips are made using the slicing knife, circular knife spindle and slice guide feed roll. (1) Slice Guide Feed Roll, (2) Knife for Slicing Only, (3) Julienne Strips.

OPERATION

General Information

MACHINE SHIPMENT

Every Urschel machine is fully inspected and test-run before it is shipped. Machines are shipped completely assembled. Spare parts, required tools, an instruction manual and other important information are packed in a separate box and shipped in the crate with the machine.

PRE-INSTALLATION PLAN

Before installation, prepare a plan to make the use of this machine safe and efficient. This plan should consider location, electrical power source and method of feeding and collecting product. Installation should comply with all applicable safety codes and regulations.

LOCATION

Choose a location that provides machine stability, ample space, and a clear path on all sides of the machine. Provide easy access to the stop/start controls and the main power disconnect switch on the starter enclosure, and also allow room for cleaning and maintenance. The location should provide level footing, adequate lighting and ventilation and provisions for excessive noise levels. Never locate machine in an area with a potentially explosive atmosphere.

Urschel Laboratories recommends that this machine be installed at floor level. If elevating the machine is necessary, make provisions to maintain all operation, cleaning, maintenance and safety features of a floor level installation.

LIFTING THE MACHINE

⚠ CAUTION: *Always use the frame to lift or move the machine, never the starter enclosure, motor, covers or guards. Do not crush electrical cords beneath frame when lifting machine!*

Both sides of machine frame should rest on lifting forks. Remove the discharge chute if lifting forks are not long enough and lift machine from the discharge side (Figure 16).

⚠ WARNING: *Knives may be exposed when discharge chute is removed. Contact with exposed parts may cause injury.*

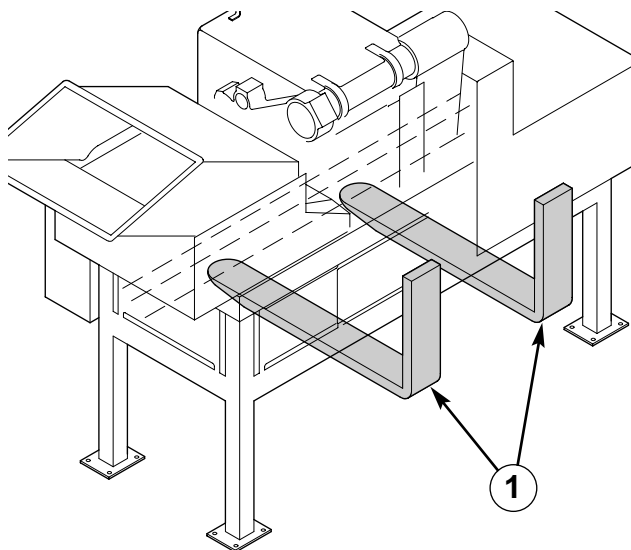

Figure 16 — Always use frame to lift or move machine.
(1) Lifting Forks.

OPERATION

Installation

ELECTRICAL POWER

The electrical installation must be performed by a *qualified electrician* in accordance with all applicable electrical codes. Refer to Figure 17, and proceed as follows:

1. **Connect the outside power source** to the terminals on top of the disconnect in the starter enclosure. The hazard alert label on the front of the starter enclosure specifies proper voltage for this machine. To maintain the watertight feature of the starter enclosure, use “liquid tight” or rigid conduit and appropriate fittings at the power source entry point on the side of the starter enclosure.
2. **Connect ground conductor** (green or green and yellow striped wire) to the earth termination point located on back panel inside the starter enclosure.
3. **Connect the wiring** so the impeller turns clockwise when viewed through the feed opening.
4. **Securely fasten screws** on the starter enclosure door when finished with installation.

NOTE: *If voltage is not at least 95% of specified voltage, the motor may become overloaded during operation.*

OPERATION

Installation

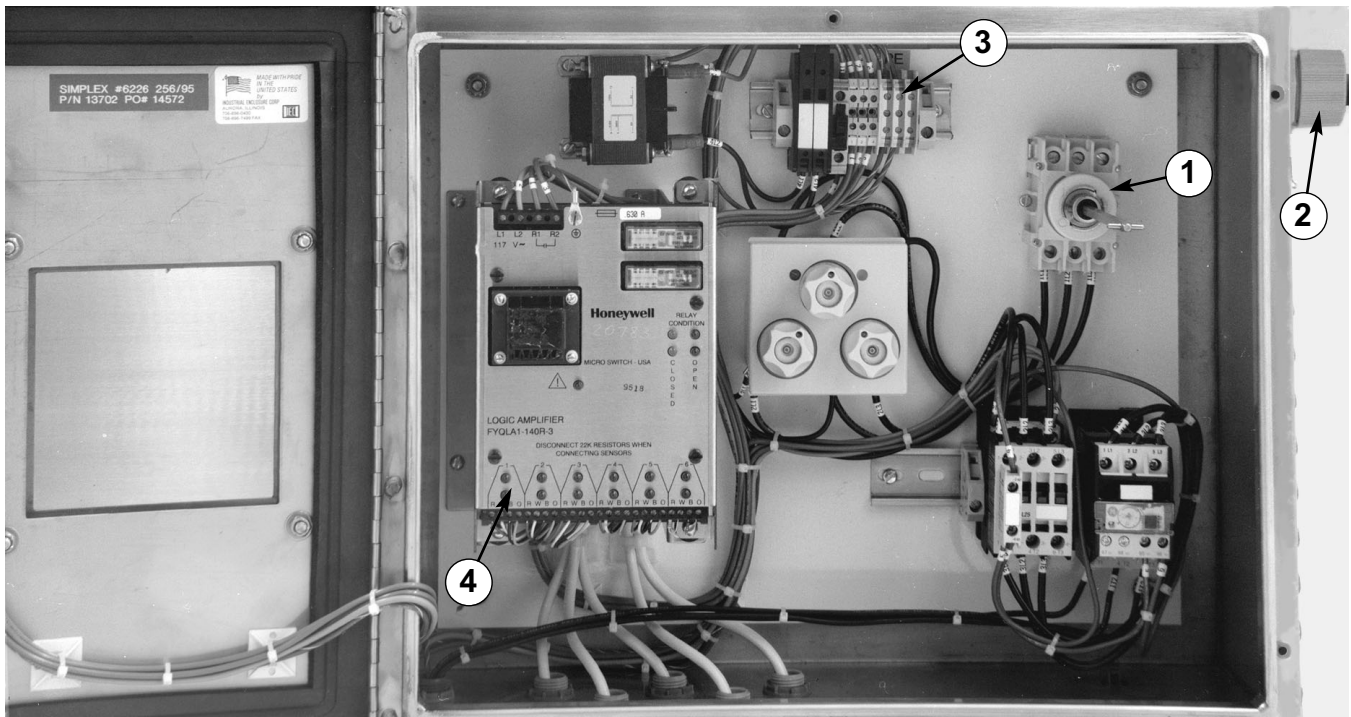
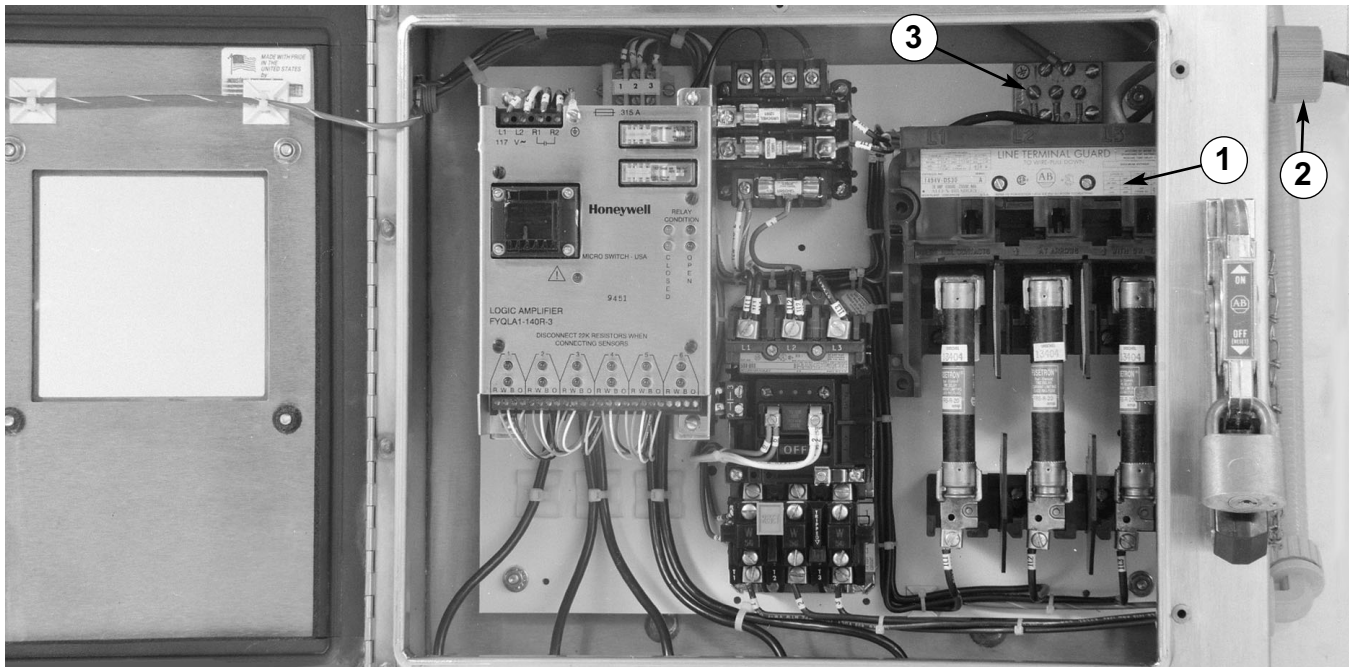

Figure 17 — Interior of starter enclosure (NEMA* configuration, top, and IEC** configuration, bottom). (1) Disconnect, (2) Power Source Entry Point, (3) Earth Termination Point, (4) Amplifier.

* National Electrical Manufacturers Association

** International Electrical Commission

OPERATION

Safety Switches

The electrical system has prewired safety switches on certain covers and guards to prevent the machine from operating when these covers or guards are removed.

⚠ WARNING: *Before operating the machine, a qualified trained person should check the safety switches by the following procedure. Be careful to avoid contact with cutting parts and sharp edges exposed during these tests!*

AMPLIFIER

The amplifier, viewed through the starter enclosure window, indicates the condition of the safety switch circuits (see Figure 18, page 23). When the green “relay condition” LEDs are illuminated, all circuits are closed and machine is ready for operation.

When one or both of the red “relay condition” LEDs are illuminated, one of the safety switches is creating an open circuit. The illuminated red “switch output” LEDs will indicate the problem source.

When the red “attention” LED is flashing and all sensors and actuators are within specified sensing distance, the power to the machine must be turned off and then on again to reset the amplifier. If the amplifier will not reset, call a qualified electrician to locate and repair the fault (see “Amplifier”, page 59).

SAFETY SWITCH TEST

⚠ WARNING: *There is a problem in the safety switch circuit if the LEDs are not lit as indicated or if, having removed a cover or guard equipped with switch, the machine can be started. DO NOT operate the machine in this condition! Call a qualified electrician to locate and repair the fault immediately. See “Inspection”, page 58.*

1. **With all covers and guards in place**, turn the power disconnect switch to “**I**” (ON). Only the green “relay condition” LEDs on the amplifier should be lit. Turn power disconnect switch to “**O**” (OFF).
2. **Remove or open one cover or guard equipped with switch.** Turn power disconnect switch to “**I**” (ON). Only the red “relay condition” LEDs and the red “switch output” LEDs corresponding to the switch on the removed or open cover should be lit on the amplifier. If LEDs are lit correctly, push the “**I**” (START) button. The safety switch circuit has been interrupted and machine should NOT start. If the machine does start, that safety circuit has failed. Push the “**O**” (STOP) button, then **disconnect and lock out power source.** Call a qualified electrician to locate and repair the fault immediately.
3. **Turn the power disconnect switch to “O” (OFF)** and replace or close the cover or guard.
4. **Individually remove or open each additional cover or guard equipped with switch** and repeat steps 2 and 3. Make sure all covers and guards are securely in place after all switches have been tested.

OPERATION

Safety Switches

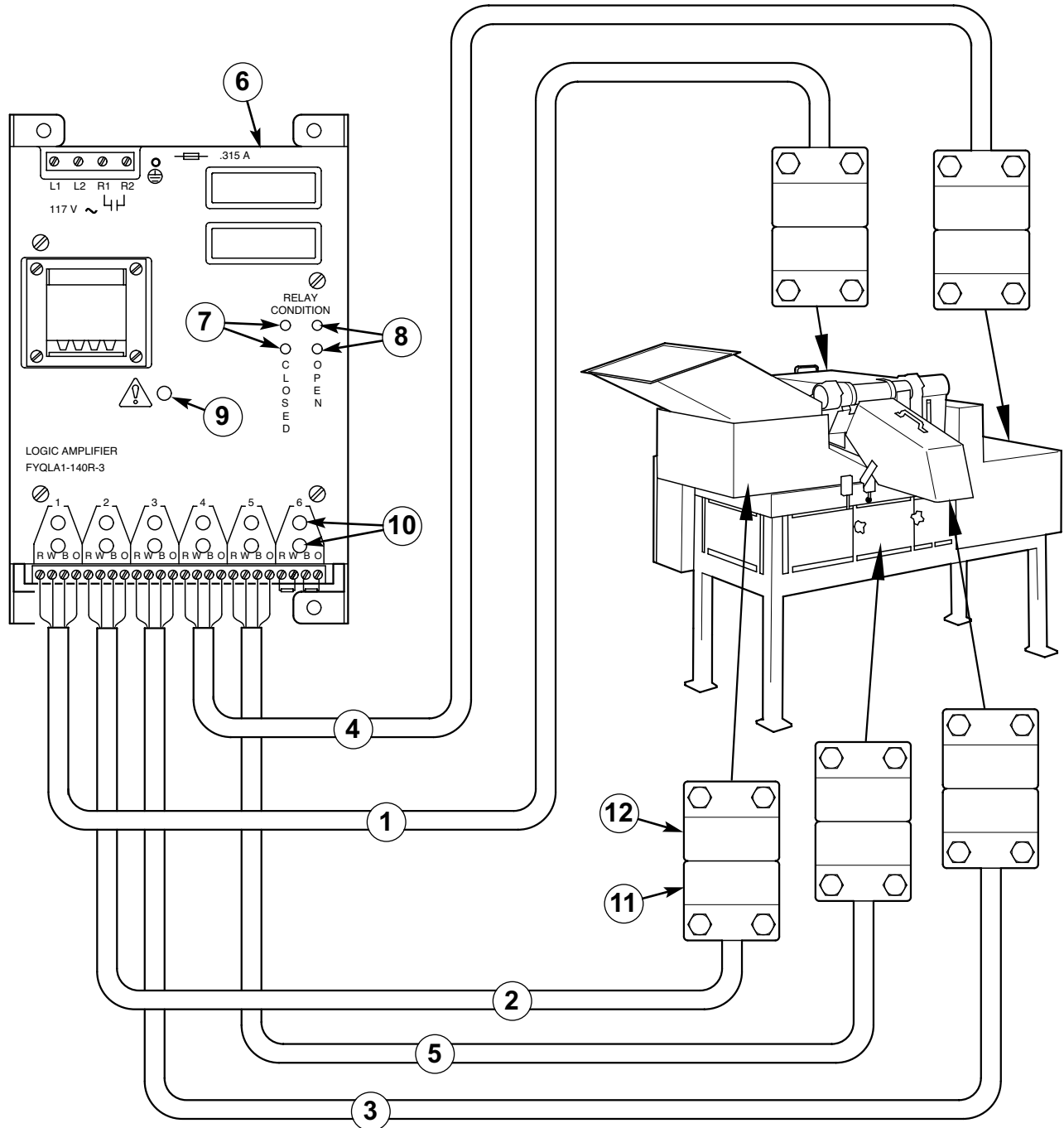

Figure 18 — Amplifier and safety switches with corresponding covers and guards (1) Chip Chute Enclosure, (2) Feed Hopper, (3) Discharge Chute, (4) Motor Cover, (5) Side Cover, (6) Amplifier, (7) Green “Relay Condition” LEDs, (8) Red “Relay Condition” LEDs, (9) Red “Attention” LED, (10) Red “Switch Output” LEDs, (11) Sensor, (12) Actuator.

OPERATION

Start-up and Stopping

PRE-START CHECKLIST

After all requirements in this checklist have been met, the machine is ready for operation.

1. **Safety:** All operators must have a thorough understanding of the safe operation of this machine (Figure 19).
2. **Location:** Machine must have ample space on all sides so that operators can move safely and easily in a clean, dry work area.
3. **Electrical power:** Machine must be properly wired and the starter enclosure door screws securely fastened.
4. **Safety switches:** Switches must be in working order with guards securely in place.

⚠ WARNING: KEEP HANDS AWAY FROM FEED OPENING

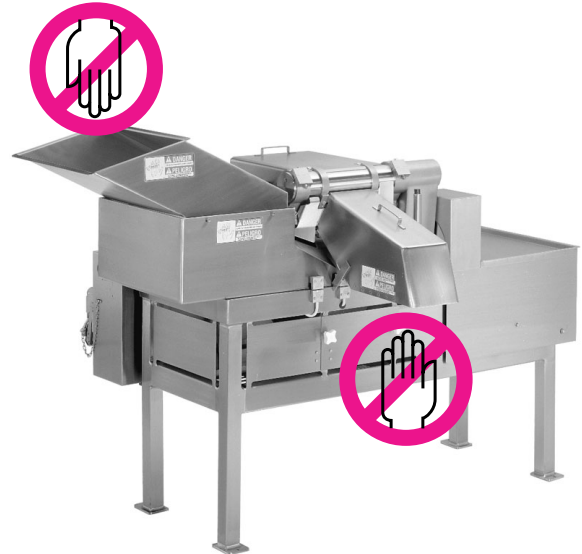

⚠ WARNING: KEEP HANDS AWAY FROM DISCHARGE OPENING

Figure 19 — Read and obey all warnings in this manual and on the machine.

START-UP PROCEDURE

1. **Make sure all foreign objects and product** have been removed from the feed area.
2. **Unlock power disconnect switch.**
3. **Move lever to “I” (ON).**
4. **Press the “I” (START) button.**
5. **Let machine reach full operating speed** before feeding product.
6. **If machine fails to start** see “Troubleshooting”, page 46.

STOPPING PROCEDURE

⚠ WARNING: Never remove covers or guards while machine is running! Contact with exposed rotating parts may cause severe injury.

1. **Stop feeding product.** This allows remaining product to be cut and discharged.
2. **Flush the feed area thoroughly** with a generous amount of water **BEFORE** stopping the machine. See page 28 for complete cleaning procedures.
3. **Push “O” (STOP) button** then disconnect and lock out power source.

FEEDING METHOD

⚠ CAUTION: *Do not allow foreign material such as tools, hardware, stones, wood, bottles or cans to enter the feed area. The cutting parts will be damaged or destroyed and the product contaminated.*

The feeding method affects the quality and capacity of the finished product. A steady, uniform flow of properly sized product from a conveyor or similar feeding system yields the best quality and greatest capacity. Dumping large quantities of product into the feed opening will produce undesirable cuts and can overload the motor, clog the feed opening or jam the cutting unit. Continuous overfeeding or jamming will also cause premature damage and failure of cutting parts and drive train. For best results, product entering the feed hopper should not exceed 5-1/2" in any dimension.

Except for an emergency, never start or stop the machine when the impeller is full of product. This puts a tremendous strain on the motor, bearings and cutting parts. In addition, product that is cut before the machine has reached full operating speed may be of such poor quality that it must be discarded.

OPERATION

Machine Overload or Jam

MOTOR OVERLOAD

If the motor shuts off during operation, it is likely that it has been overloaded. After maintenance personnel have corrected the problem (allowing at least five minutes for thermal overloads to cool) machine may be restarted by first pressing the “RESET” button on the starter enclosure then starting in the normal manner. If motor again shuts off, see “Troubleshooting”, page 64.

CORRECTING MACHINE OVERLOAD OR JAM

⚠ DANGER: *Never try to remove jammed product while the machine is running! You may come into contact with cutting parts which could cause severe injury!*

DANGER!



1. Push “O” (STOP) button then disconnect and lock out power source.
2. Only qualified trained personnel should proceed to step 3.
3. Remove or open guards to expose jammed area and visually verify that all parts have stopped.
4. Remove the obstruction. *Keep hands away from cutting parts.*
5. Remove all product from the feed area and replace or close all covers and guards.
6. Machine is ready to restart and resume feeding product. If proper feeding procedures are followed, product will flow evenly into feed areas.

⚠ CAUTION: *If product continues to jam in the feed or discharge areas, DO NOT operate the machine. Contact your supervisor.*

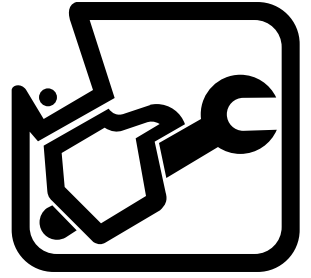

MAINTENANCE

MAINTENANCE

Cleaning

NOTE: Maintenance Videotapes are available for this machine. See page 66.

IMPORTANCE OF DAILY CLEANING

Stainless steel parts will eventually corrode if salty and acidic product juices are not removed completely. Also, product that remains in the cutting unit may harden making future cleaning difficult and encouraging bacterial growth. Heavy product build-up on cutting parts can reduce cutting efficiency and cause the loss of critical tolerances and clearances.

CLEANING AGENTS

The selection of cleaning agents or their solution strength will depend on the application or process in which the machine is involved. Consult your cleaning materials supplier for selecting and using the proper cleaning agent to meet the sanitizing requirements for your process. Cleaning supplies should be suitable for use with 300 and 400 series stainless steel and manganese aluminum bronze alloy. Excessive solution strength and soaking time or excessive soaking time alone may chemically harm or destroy these and other materials.

DAILY CLEANING PROCEDURES

Only qualified trained personnel should clean the machine. Clean the machine according to your company policy and at the end of each production day.

NOTE: Never use abrasives, metal tools, wire brushes or sandpaper to clean any parts. Scrape with wooden or plastic tools if necessary.

1. **Clean outside of machine with water.**
2. **Flush product from cutting parts.** Direct a stream of water or cleaning solution into feed opening while machine is running.

⚠ WARNING: *Make certain that all covers and guards are in place while machine is running! Maintain a safe distance from machine. Do not insert hose or cleaning tools into feed opening!*

3. **Stop the machine.** Disconnect and lock out power source. Thoroughly wash all sheet metal covers. (See "Removal", page 30.)
4. **Remove and disassemble all cutting parts.** The dicing unit can be lifted from the operating position and lowered to the maintenance position. This position simplifies cleaning, inspection and repair. When lowering the dicing unit into the operating position, carefully turn and mesh the gears as the unit settles into position. The dicing unit should always be fastened in place with the hand knobs before the machine is operated. Remove and disassemble all cutting parts. See "Disassembly", pages 32 and 36. Rinse cutting parts thoroughly with water or appropriate cleaning solution. If cleaning solutions are used, rinse thoroughly with water.
5. **Clean remaining portion of machine.** A forceful stream of water will remove most of the product. Use cleaning solutions when necessary and rinse thoroughly.

RECOMMENDED LUBRICANT

Use a food grade lubricant that is non-toxic, sanitary and approved for incidental food contact. The lubricant recommended for this machine, except motor, is Haynes® Lubri-Film (listed as H-1 by the USDA). Lubricant may be purchased from Urschel Laboratories in spray cans for gears and grease cartridges for bearings. See “Tools” , page 69.

LUBRICATION POINTS

The machine has a total of seven (7) grease fittings (Figure 20). Lubricate the fittings until grease comes out from around bearings and thrust washers. Lubricate slice adjustment bearing with a drop of oil immediately after machine has been cleaned (Figure 21).

LUBRICATION SCHEDULE

Lubricate as follows:

1. **Every four hours** of operating time.
NOTE: 22 knife crosscut spindle bearings require lubrication every two hours.
2. **After cleanup** to force cleaning solutions from bearings. Before replacing covers, lubricate until grease appears at the bearings and thrust washers.
3. **After maintenance** to replace any grease lost during these procedures.

GEAR LUBRICATION

Lubricate all gears daily or when the coating of lubricant has worn away from tooth faces. Use the spray lubricant supplied with machine, following directions on the label. Gears are accessed by lifting the motor cover and the dicing unit.

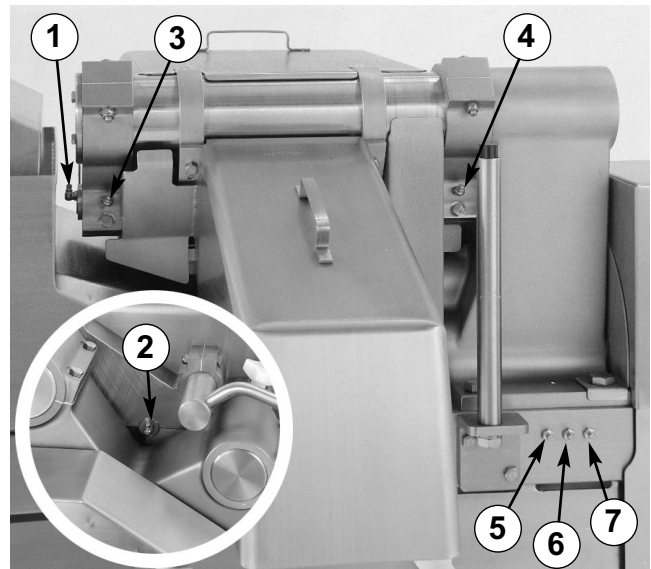

Figure 20 — Grease fittings numbered 1 and 2 are for each end of the crosscut knife spindle shaft, 3 and 4 are for the circular knife spindle, and 5, 6 and 7 are for the main bearings.

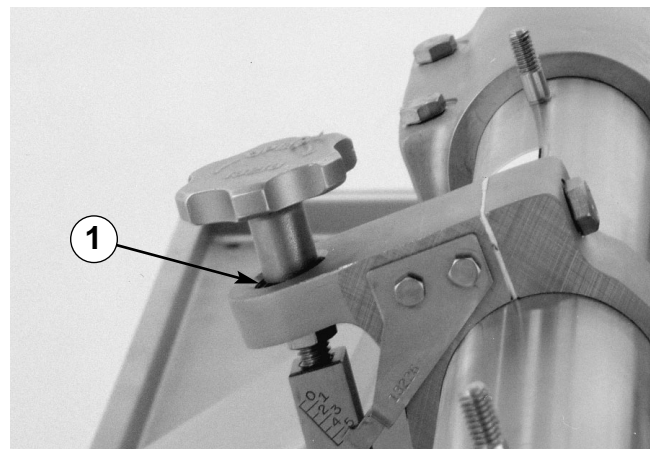

Figure 21 — Lubricate slice adjustment bearing (1).

MOTOR LUBRICATION

Lubricate according to instructions furnished by motor manufacturer.

MAINTENANCE

Covers and Guards

REMOVAL

⚠ WARNING: *Disconnect and lockout power source and visually verify that machine has come to a complete stop before removing any cover or guard. Do not operate this machine if any cover or guard is removed. Operating machine with covers or guards removed may result in serious injury!*

Remove the following covers and guards to service the various areas of the machine (Figure 24, page 31):

Discharge chute: remove to service dicing unit.

Motor cover: release latch (Figure 22) and tilt away to service drive train and gears.

Feed hopper and hopper extension: remove to service slicing unit.

Chip chute enclosure: remove to service dicing unit.

Bottom grid: generally does not require removal.

Gear guard: remove to service drive train.

Drive guard: generally does not require removal.

Shield: remove to service dicing unit.

Side cover or juice chute: side cover generally does not require removal. Remove juice chute to service slicing unit.

INSPECTION

Inspect all covers and guards for damage. Bent or twisted parts will not fit on the machine properly and may prevent safety switches from lining up. Straighten parts or replace if necessary.

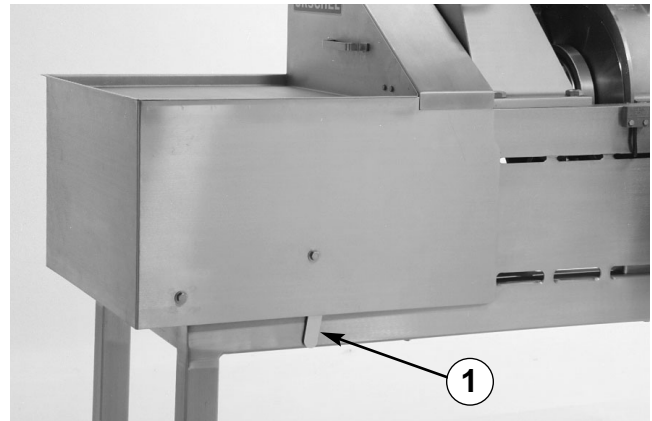

Figure 22 — Release latch for motor cover (1)

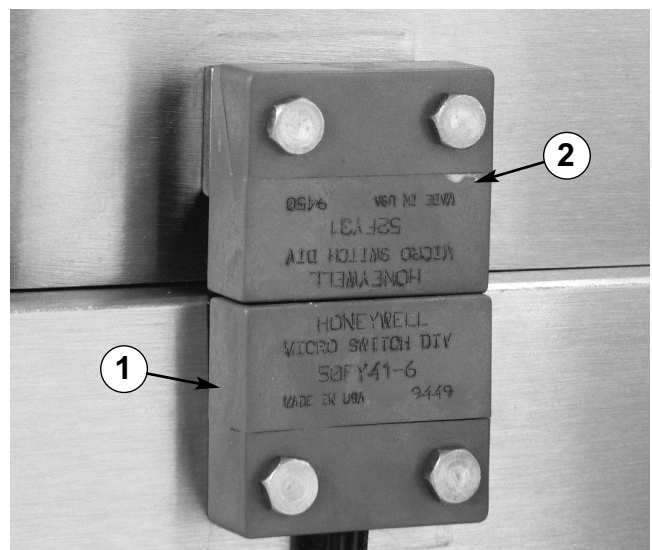

Figure 23 — Safety switch sensors and actuators must be aligned and within 1/16" (1.6 mm). (1) Sensor, (2) Actuator.

INSTALLATION

Replace all covers and guards in their proper locations; replace fasteners and tighten securely. Covers and guards equipped with safety switches must have actuators within 1/16" (1.6 mm) of sensors to complete safety switch circuit (Figure 23).

MAINTENANCE

Covers and Guards

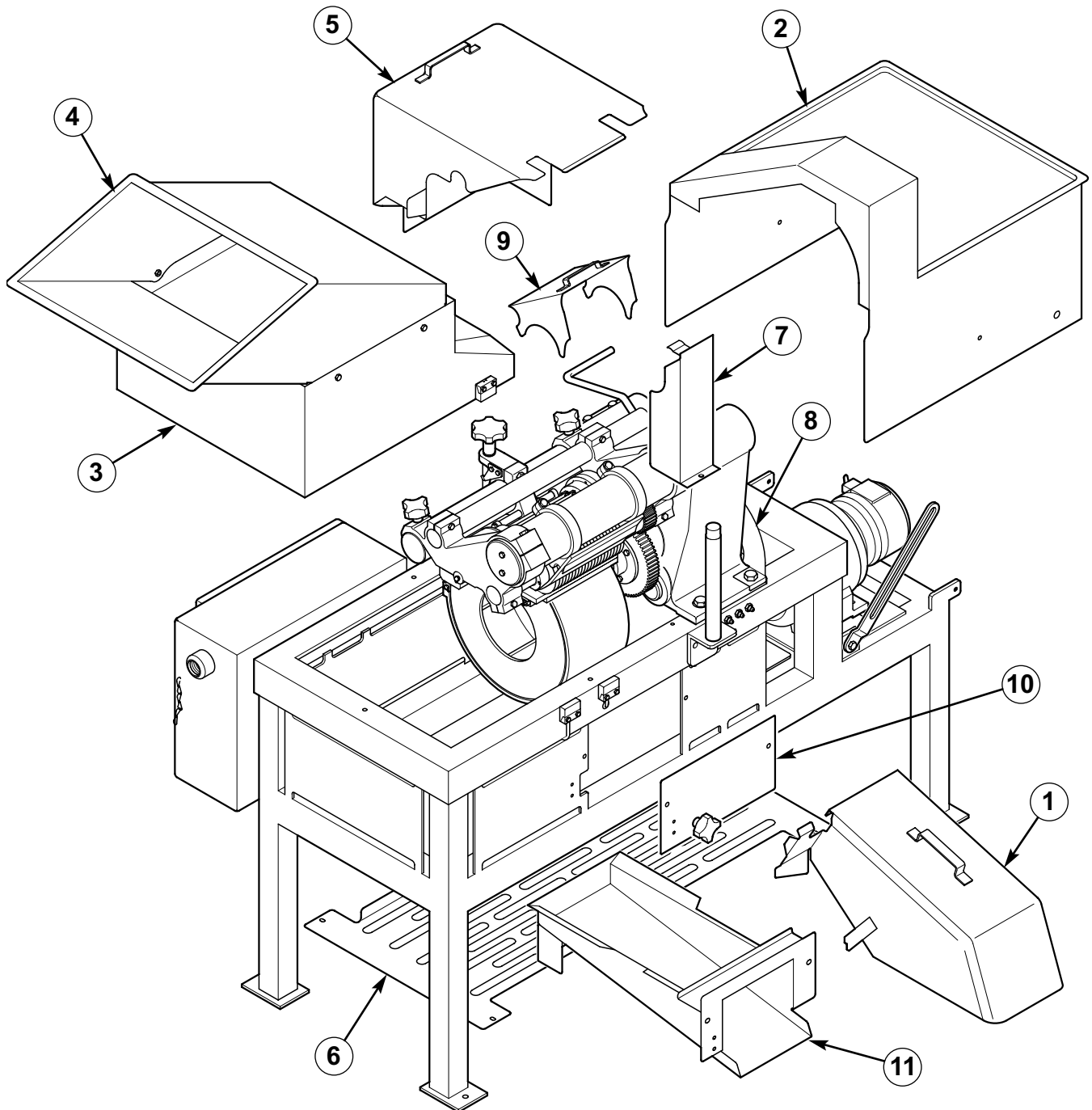
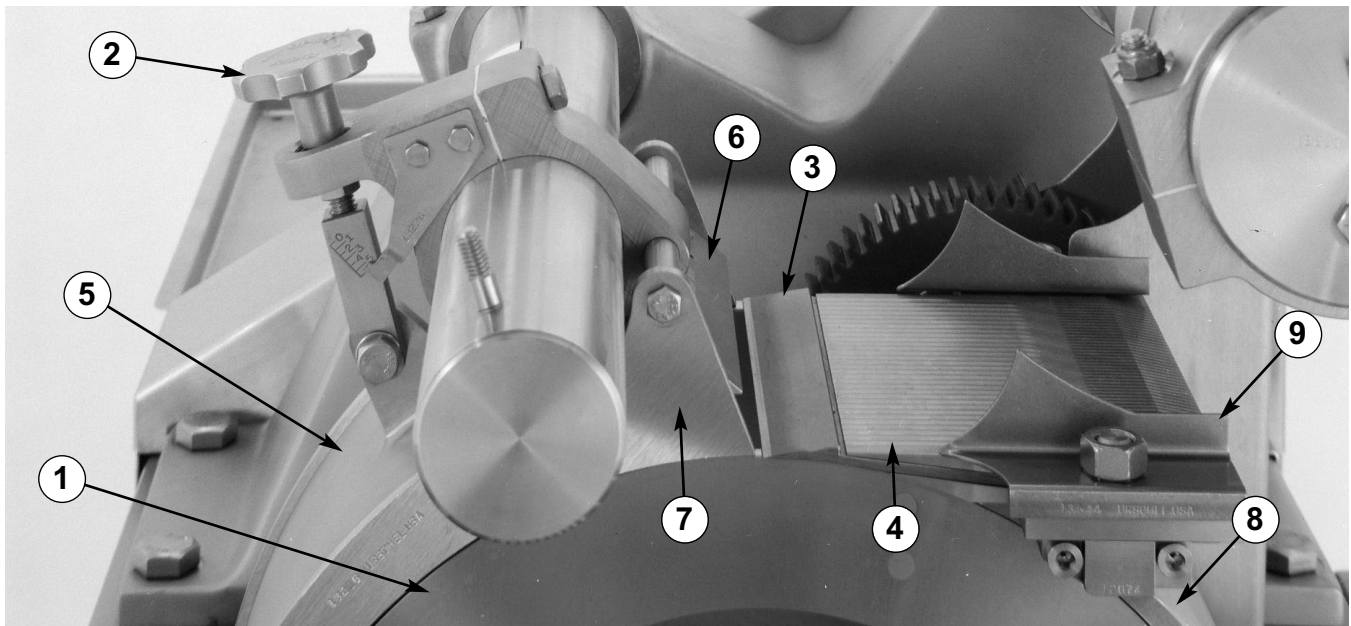

Figure 24 — Covers and guards. (1) Discharge Chute, (2) Motor Cover, (3) Feed Hopper, (4) Feed Hopper Extension, (5) Chip Chute Enclosure, (6) Bottom Grid, (7) Gear Guard, (8) Drive Guard, (9) Shield, (10) Side Cover, (11) Juice Chute (alternate part, replaces side cover).

MAINTENANCE

Slicing Unit



DISASSEMBLY

1. **Disconnect and lock out power source.** Remove discharge chute, chip chute enclosure, shield and feed hopper. See pages 30 and 31. Remove hand knobs and swing dicing unit into maintenance position.

⚠ WARNING: *Wear protective gloves when handling cutting parts (see “Tools”, page 69). Cutting parts are sharp and can cause injury.*

2. **Remove slicing knife holder:** Remove the two nuts and slice guides, then lift slicing knife holder off studs (Figure 25).
3. **Remove slicing knife from holder:** Insert small tab of knife remover against angled corner of slicing knife (Figure 26). Tap opposite end of remover lightly to start knife out of slot. Pry knife up then use large tab with a jacking motion to force knife further out of the slot. When you can grasp knife safely, remove from holder.

4. **Remove impeller.** Impeller is held in place by three lock nuts fastened to studs on impeller shaft. Lift impeller *carefully* out of the machine.
5. **Remove gate extension strip** (if necessary): Remove by unfastening the two screws and lift from locating pins.

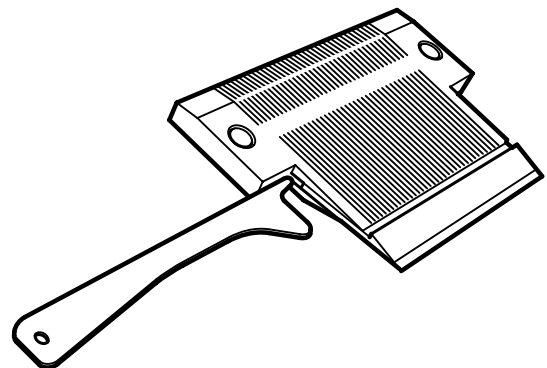

Figure 26 — Removing the slicing knife from holder.

INSPECTION

All parts should be inspected for serviceability and repaired or replaced if necessary. For information on knife care and sharpening, see page 60 and refer to the “SHARP” bulletin provided with the machine.

Knife holder: Clean the slot thoroughly so the knife will seat properly in the bottom of the slot. Check bottom of slicing knife holder and its mounting surface for burrs or dried product. Clean and hone if necessary. Product build-up on this surface usually indicates a bent slicing knife holder. Return to Urschel Laboratories for straightening.

Slicing knife: Clean thoroughly. Inspect knife edge for nicks or burrs; sharpen or replace if necessary.

REASSEMBLY

1. **Install impeller.** Be careful not to damage studs on impeller shaft. Fasten with the three lock nuts.

NOTE: *If the locking effect on these nuts has worn off and they can be turned by hand, they should be replaced.*

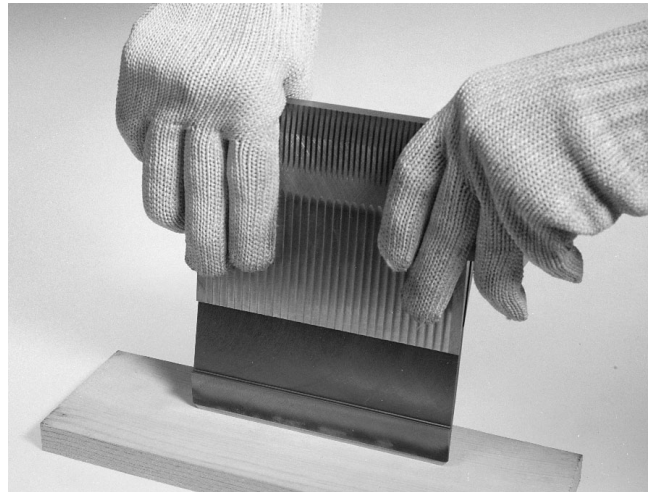

Figure 27 — Installing the slicing knife in the slicing knife holder.

2. **Install slicing knife in holder:** With slicing knife edge on a block of wood, push down on the holder to force the knife all the way into the slot (Figure 27). Knife should be centered in the holder. Press down on knife again making sure it is seated properly in the slot.
3. **Install the slicing knife holder** and slice guides over the pins and studs. Fasten securely with the two nuts.
4. **Install gate extension strip:** Stamped part number must face out.
5. **See “Adjustments”, page 34.**

MAINTENANCE

Slicing Unit

ADJUSTMENTS

NOTE: Foreign material entering the machine may strike the slicing knife and cause the slice case to rotate out of adjustment. This results in incomplete cuts and/or crosscut knife damage due to the knives striking the shear edge of the slicing knife. **TO ADJUST:**

Slice case: (Dicing unit in operating position.):

1. **Check hinge tube clearance.** See “Adjustments”, page 39.

2. **Check gear alignment.** The gear on the circular knife spindle should align with the gear on main support casting. The gears on the opposite side of the main support casting should also be aligned. If gears are misaligned, loosen pinch bolt on slice adjustment clamp (Figure 28), the two pinch bolts on bottom of main support casting and pinch bolts that hold circular knife spindle bearings. Move the case, slice adjustment clamp and circular knife spindle until all gears are aligned and circular knives are centered in slots of slicing knife holder. Tighten pinch bolts for circular knife spindle bearings.

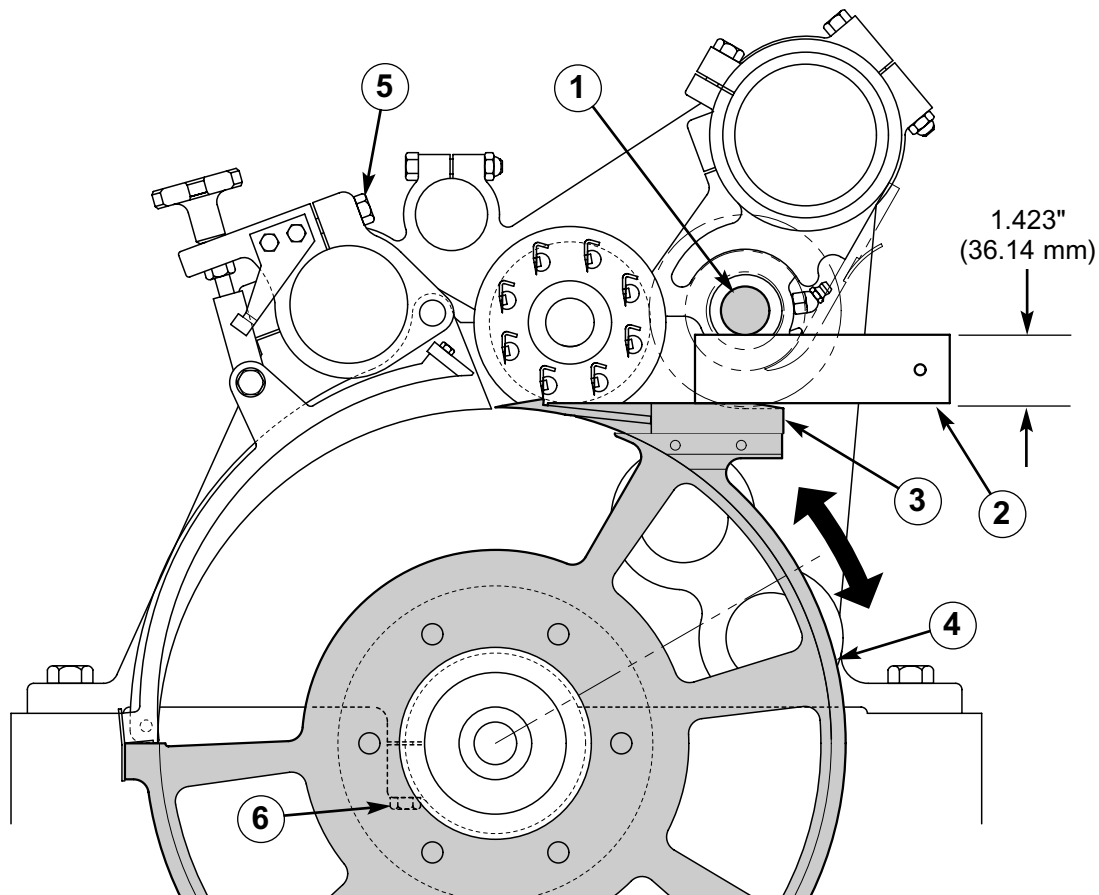

Figure 28 — Rotate slice case to set circular knife clearance. (1) Circular Knife Spindle Shaft, (2) Gauge, (3) Slicing Knife Holder, (4) Slice Case, (5) Pinch Bolt, slice adjustment clamp, (6) Pinch Bolts, bottom of main support casting.

3. **Remove circular knife spindle and stripper plate** and reinstall shaft only.
4. **Rotate case assembly** until slice case gauge fits between the circular knife spindle shaft and the slicing knife holder (Figure 28). Maintain gear alignment while rotating case. Retighten pinch bolts on main support casting. Re-check with gauge in several locations. Adjust chip guards and slice thickness (see below).

Chip guards: (Dicing unit in maintenance position.) Loosen pinch bolt in slice adjustment clamp. Rotate until there is approximately .015" (.381 mm) clearance between chip guards and impeller (Figure 29). Retighten pinch bolt.

Swing dicing unit into operating position and fasten with the hand knobs. Raise the motor cover, release the motor brake and rotate the belt pulley by hand. If there is metal-to-metal contact recheck adjustments or refer to "Troubleshooting", page 63.

Slice thickness: Turn slice adjusting knob until desired thickness is indicated on adjusting nut (Figure 30). Each increment equals 1/8" (3.2 mm). Since each product cuts differently, the finished product must be measured to determine if additional adjustments are necessary. Indicator arm can be readjusted to match slice thickness by loosening cap screws and repositioning indicator arm. Replace all covers and guards.

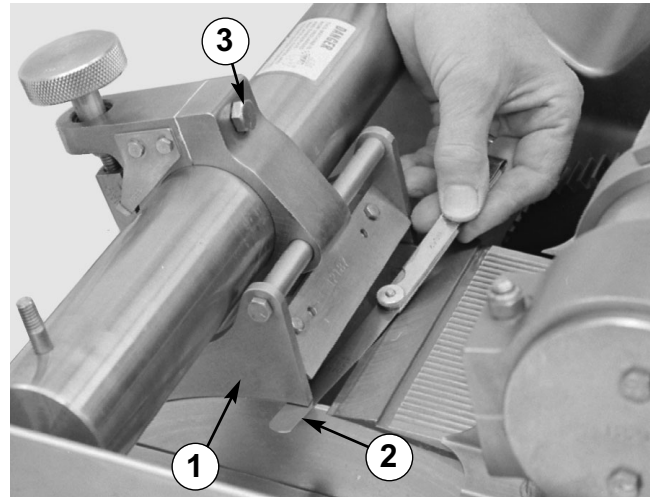

Figure 29 — Setting chip guard clearance. (1) Chip Guard, (2) Feeler Gauge, (3) Pinch Bolt.

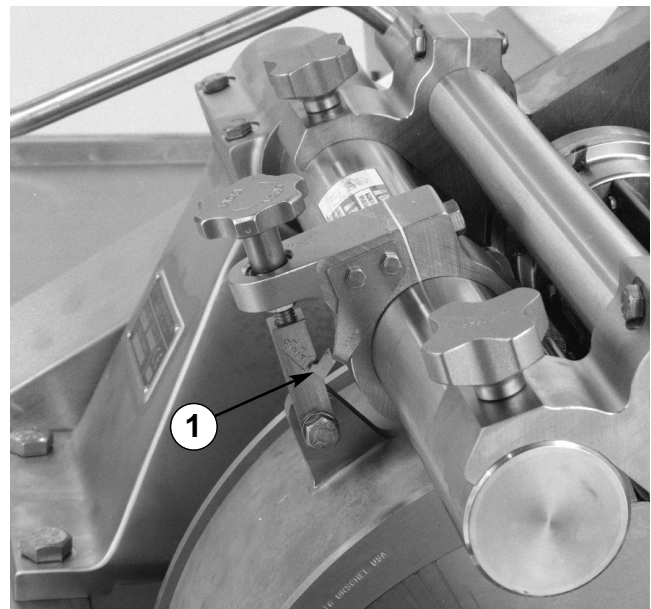

Figure 30 — Slice thickness adjustment. (1) Indicator Arm.

SAFETY

Dicing Unit

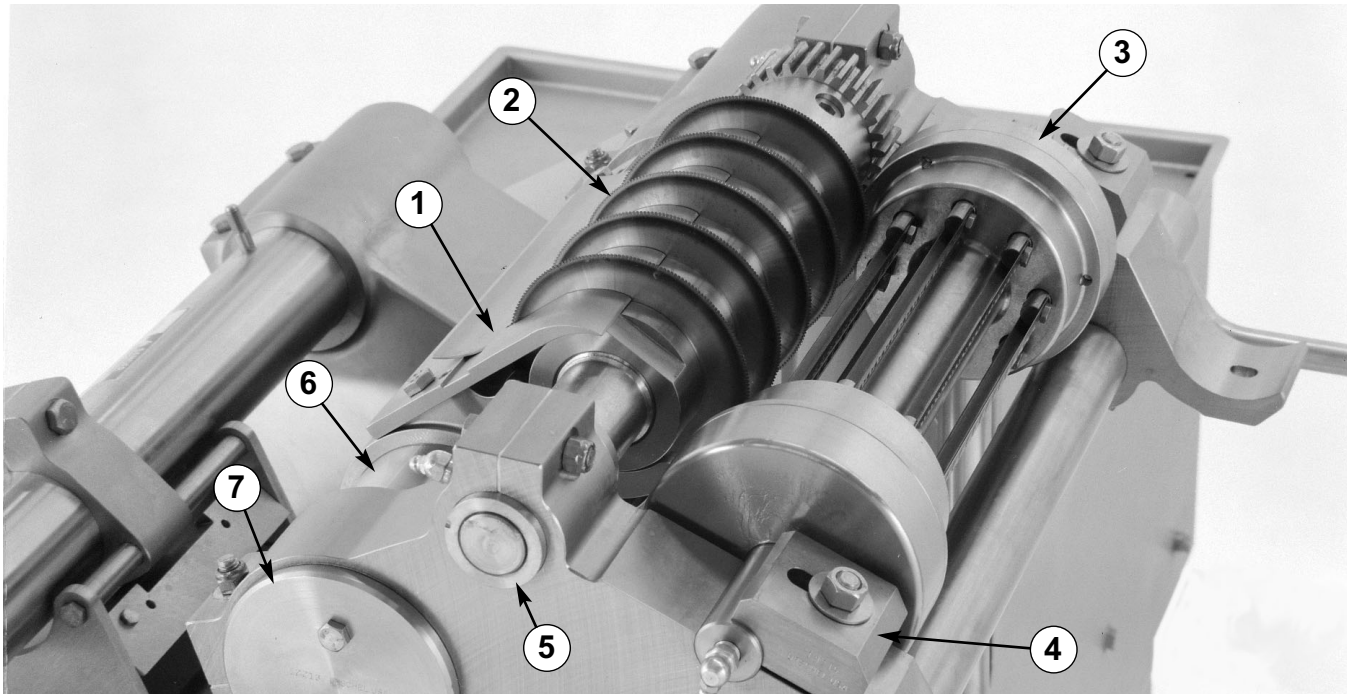

Figure 31 — The dicing unit. (1) Stripper Plate, (2) Circular Knife Spindle, (3) Crosscut Knife Spindle, (4) Side Frame Cap, (5) Circular Knife Spindle Bearing, (6) Hinge Tube, (7) Retaining Cap (fastened to support bar).

DISASSEMBLY

- 1. Disconnect and lock out power source.** Remove discharge chute, chip chute enclosure and shield. Swing dicing unit into maintenance position.
- 2. Remove crosscut knife spindle.** Loosen screw in each side frame cap and slide caps clear of shaft (Figure 31). Lift the crosscut knife spindle by the ends of the shaft, *not the knives*. Set spindle aside, bracing it to prevent it from rolling.
- 3. Remove stripper plate.** Unfasten the two screws and lift stripper plate from dowel pins.
- 4. Remove circular knife spindle.** Remove screw in spindle next to the gear. Push shaft part way out of side frame. Hold spindle at gear end and with your other hand remove shaft as you allow spindle to rest on clamp ring “cradle”. Remove spindle and carefully set it aside on the knife edges, bracing it to prevent it from rolling.

⚠ WARNING: *Wear protective gloves (see “Tools”, page 69) when handling dicing unit parts. Spindles are heavy and contain sharp knives.*

INSPECTION

All parts should be inspected for serviceability and repaired or replaced if necessary.

Crosscut knife spindle: Check for sideways movement of crank and idler pins. Rotate shaft in both directions noting any free movement before knives begin to rotate. If these conditions exist, the spindle must be disassembled and each part individually inspected to determine needed repairs. See "Disassembly", page 40.

Stripper plate: Clean all product from between "fingers", making sure none are bent or damaged. Return to Urschel Laboratories for repair if necessary.

Circular knife spindle: Clean product from between knives and inspect for damage or wear. See "Disassembly", page 53.

Thrust sleeves: Replace if scored or worn to less than .120" (3.05 mm) thickness. See "Reassembly", page 54.

Circular knife spindle bearings: Replace when inside diameter measures more than 1.007" (25.58 mm) or the inside of the bearing has become scored.

Gears: Check for worn or damaged teeth. Replace if necessary.

MAINTENANCE

Dicing Unit

REASSEMBLY

1. **Replace circular knife spindle bearings** if necessary. Loosen bearing pinch bolt in each side frame and remove bearings. Install new bearings, aligning the notch and grease fitting (Figure 32). The notch indicates the location of the grease hole in the bearing. After making the necessary adjustments (see page 39), retighten pinch bolts to 5 foot pounds (6.78 Newton meters).

NOTE: *Overtightening pinch bolts may distort the bearings! Shaft must slide in and rotate freely.*

2. **Install circular knife spindle:** (Dicing unit in maintenance position.) Slide shaft (hole end first) into left side frame. Hold spindle at the gear end between the side frames. Slide shaft into place so the holes in the spindle and shaft line up. Fasten spindle to shaft with screw and torque to 45-50 foot pounds (61-68 Newton meters).
3. **Install stripper plate:** (Dicing unit in maintenance position.) Locate on the dowel pins and fasten with the 2 screws. Circular knives must be centered in slots.
4. **Install crosscut knife spindle:** (Dicing unit in maintenance position.) Place spindle in side frames so locating hole on shaft fits onto pin in left side frame (Figure 33). Knife edges should face up. Slide caps over shaft and tighten screws. Do not overtighten.
5. **Adjust the components of the dicing unit.** See "Adjustments", page 39.

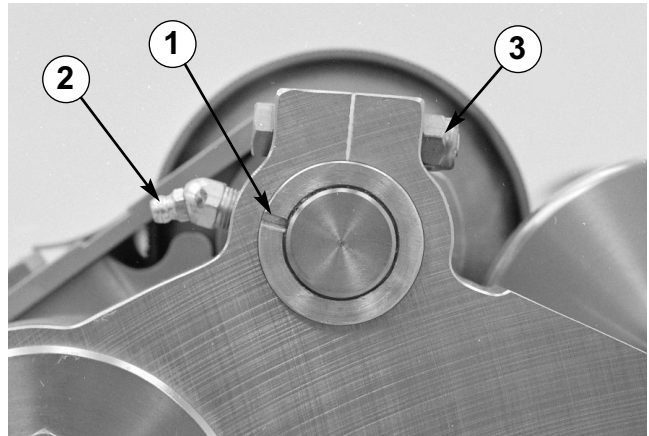

Figure 32 — Keep the notch on the bearing aligned with grease fitting to insure proper lubrication. (1) Notch, (2) Grease Fitting, (3) Pinch Bolt.

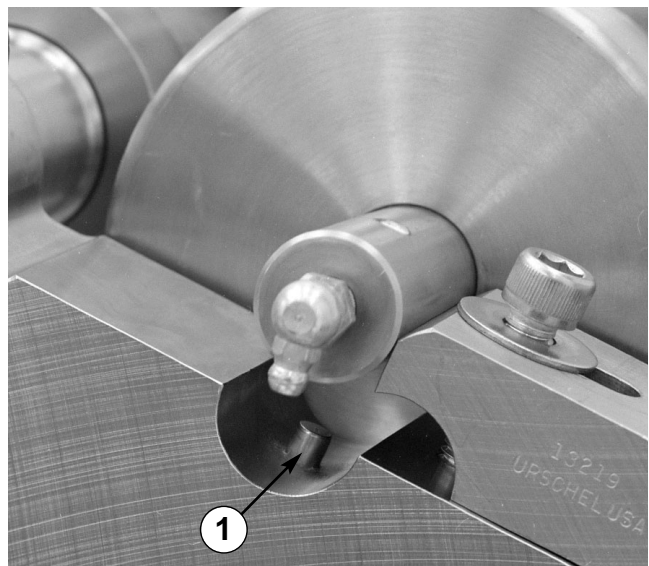

Figure 33 — Installation of 7, 8, 10, 12, 14 and 16 knife spindles. (1) Side Frame Pin.

ADJUSTMENTS

Hinge tube: Check hinge tube clearance: if dicing unit slides side-to-side even a slight amount, hinge tube clearance is excessive. Loosen the two pinch bolts that hold the support bar on the main casting (see page 76). Insert a .0015" (.038 mm) feeler gauge between the retaining cap and the end of the hinge tube. Push the support bar into the main casting and tighten the pinch bolts. Remove the feeler gauge.

Circular knife spindle: The gear on the circular knife spindle should align with the gear on main support casting. If gears are misaligned, see "Adjustments", page 34. Circular knives should be centered in the slots of the slicing knife holder. End play should be .004" (.102 mm). To adjust:

1. **With dicing unit in maintenance position**, loosen bearing pinch bolts in side frames.
2. **Carefully lower dicing unit** back into the operating position, moving the spindle as needed so the knives will enter the slots and not strike the slicing knife holder.
3. **Slide bearings against spindle** until knives are centered in slots.
4. **Swing dicing unit back** into maintenance position. Tighten bearing pinch bolt opposite gear end. Insert .004" (.102 mm) feeler gauge between bearing and spindle (Figure 34); then slide other bearing against spindle. Tighten pinch bolt on gear end.

Stripper plate: Loosen pinch bolts on the clamp rings. Move stripper plate sideways or up and down until "fingers" are centered between knives and there is .030" (.762 mm) clearance between spindle and stripper plate (Figure 35). Retighten pinch bolts.

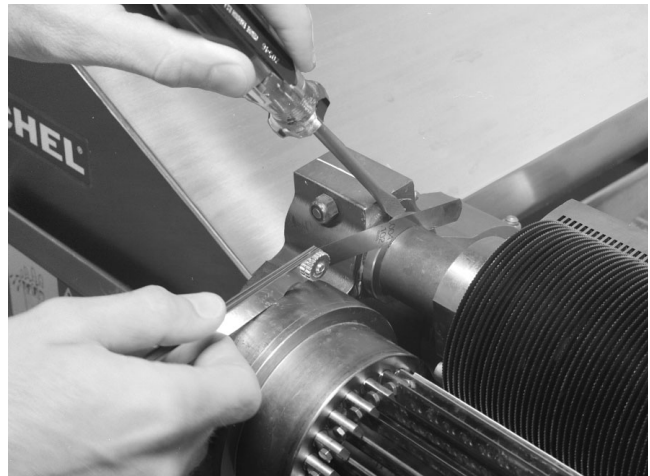

Figure 34 — Setting the .004" (.102 mm) clearance between circular knife spindle and bearing.

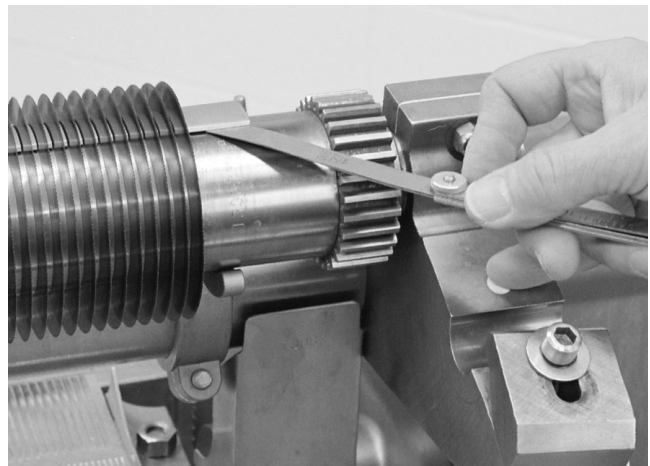

Figure 35 — Measuring clearance between circular knife spindle and stripper plate.

Swing dicing unit into operating position and fasten with the hand knobs. Raise the motor cover, release the motor brake and rotate the belt pulley by hand. If there is metal-to-metal contact recheck adjustments or refer to "Troubleshooting", page 63. Replace all covers and guards.

Lubricate the crosscut and circular knife spindles thru the grease fittings according to instructions under "Lubrication", page 29.

MAINTENANCE

Crosscut Knife Spindle Assembly

OPERATING PRINCIPLE

There are two types of crosscut knife spindle designs. The 7, 8, 10, 12, 14 and 16 knife spindles use an eccentric to maintain the “edge-down” position of the knives as they rotate past one another and around the spindle (Figure 36). This design limits the number of knives that can be placed on the spindle.

The 22 knife spindle (used for 9/32" cuts) overcomes this limitation by using a cam to keep the knife edges facing outward as the spindle rotates.

NOTE: *Inspection information and re-assembly procedures are different for the two types of spindle.*

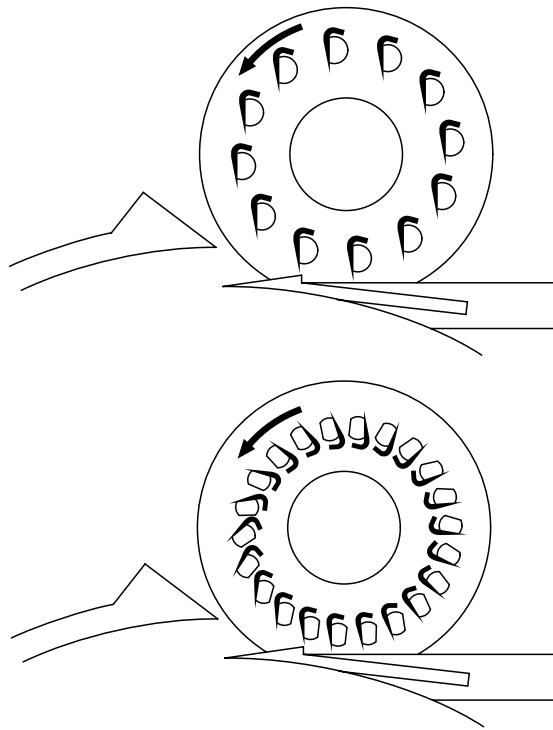

Figure 36 — Knife orientation on the two different spindle designs. “Knife edge down” in 7, 8, 10, 12, 14 & 16 knife spindles (top). “Knife edge out” in 22 knife spindle (bottom).

DISASSEMBLY (all spindles)

1. **Remove crosscut knife spindle** from dicing unit. See “Disassembly”, page 36.
2. **Remove knife screws and knives.** Place spindle in “V” block support which will allow spindle to turn but prevent it from rolling (Figure 37). Use the hex driver to remove knife screws. (At this point the idler pins should be removed from the 22 knife spindle.)
3. **Clamp spindle in soft jaw vise** onto central spool with gear side down.
4. **Remove grease fittings from shaft.** A pin held in locating hole of shaft will prevent shaft from turning.



Figure 37 — Removing crosscut knives.

MAINTENANCE

Crosscut Knife Spindle Assembly

5. **Remove end cap** with a chain wrench, turning counterclockwise (Figure 38).
6. **In the 7, 8, 10, 12, 14 and 16 knife spindle**, lift off crank bearing block, then remove shaft with eccentric. **In the 22 knife spindle**, lift off cam and remove woodruff key, then remove shaft with cam hub.
7. **Remove crank pins** from bearing block.
8. **Reverse spindle in vise**. Remove the three socket head cap screws in gear and remove gear. Pry gently with screwdriver if necessary.
9. **Remove the three socket head cap screws in the drive cap** and insert two of them into two of the holes provided for the gear fasteners (Figure 39). Turn these screws until drive cap releases from spindle. Remove screws.

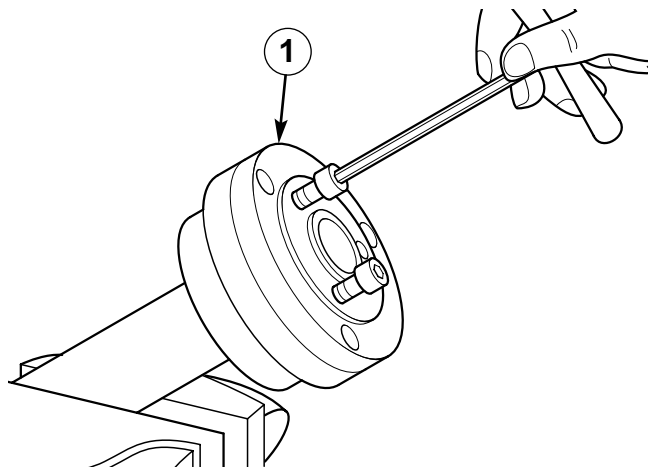

Figure 39 — Removing drive cap. (1) Drive Cap.

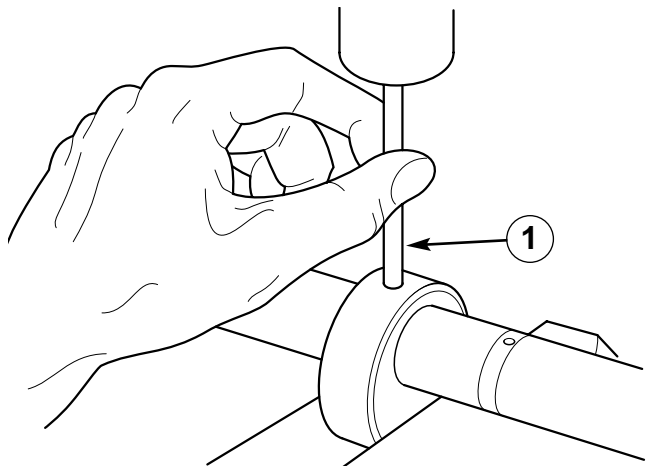

Figure 40 — Removing spring pin. (1) Pin Punch.

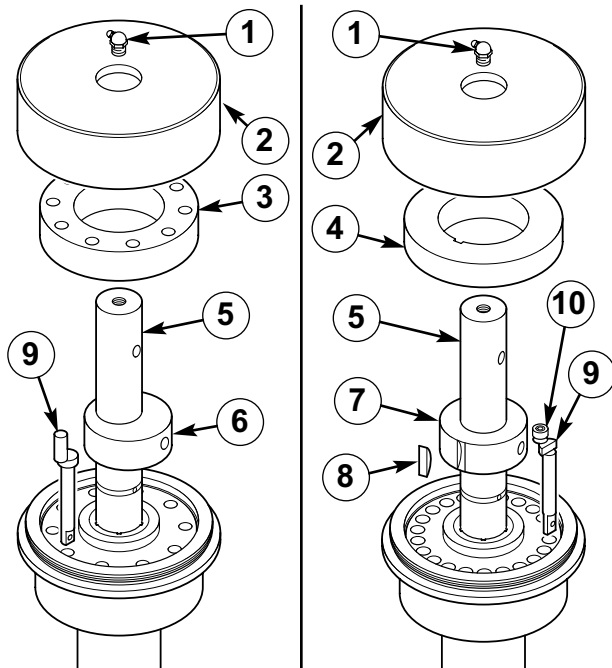

Figure 38 — Crosscut knife spindle disassembly (7—16 knife spindle, left; 22 knife spindle, right). (1) Grease Fitting, (2) End Cap, (3) Crank Bearing Block, (4) Cam, (5) Shaft, (6) Eccentric, (7) Cam Hub, (8) Key, (9) Crank Pin, (10) Roller, Crank Pin.

10. **Remove idler pins** from bearing block (7, 8, 10, 12, 14 and 16 knife spindles).
11. **Hold eccentric in vise** and drive spring pin out with pin punch (Figure 40). Slide shaft out of eccentric. The cam hub on the 22 knife spindle shaft is removed in the same way.

MAINTENANCE

Crosscut Knife Spindle Assembly

INSPECTION

All parts should be inspected for serviceability and repaired or replaced if necessary.

Clean all spindle parts thoroughly. Inspect parts for wear using the repair tolerance charts on page 43. For detailed information on care and sharpening of crosscut knives see page 60 and refer to the "SHARP" bulletin provided with the machine.

NOTE: *The crank rollers in the 22 knife spindle should be inspected as often as possible. They are inexpensive parts and frequent replacement will ensure longer spindle life and help to prevent costly repairs. Also, NEVER USE SCREWS FROM OTHER SPINDLES ON THE 22 KNIFE SPINDLE. The larger heads on these screws will strike and damage the adjacent knives.*

Drive Cap: Check for nicks or burrs. Hone if necessary.

End Cap: Check for nicks or burrs. Hone if necessary. Measure from edge to inside face (Figure 41). Re-machine or replace if dimension exceeds .946" (24.03 mm).

Bearing blocks: If bearing block replacement is necessary, the spindle should be returned to Urschel Laboratories for repair. See "Returning Parts For Repair", page 67. *This is an exacting procedure difficult to do without special tools and equipment* (see page 48). To minimize "downtime", keep a spare crosscut knife spindle with bearing blocks installed to use while one is being returned for repair.

If you must replace the bearing blocks yourself, detailed information begins on page 48. Instructional videotapes covering knife assembly maintenance, including bearing block replacement, are also available from Urschel Laboratories. See "Maintenance Videotapes", page 66.

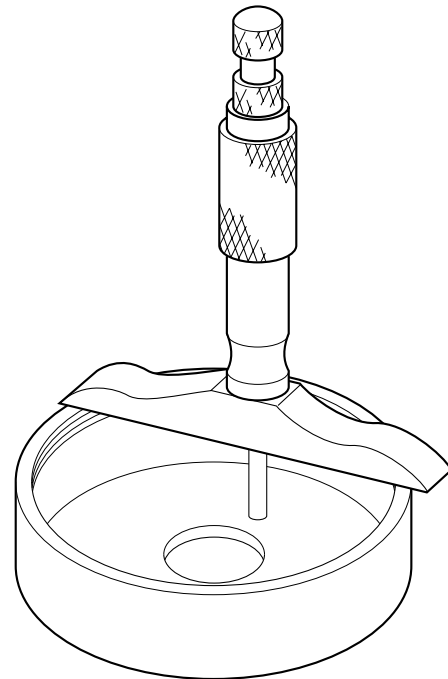

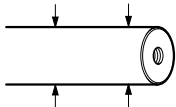
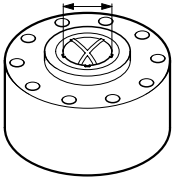
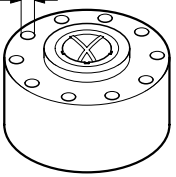
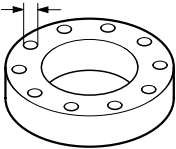
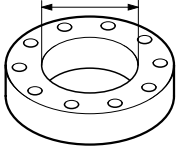
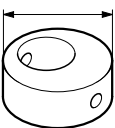
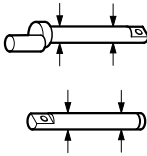

Figure 41 — Checking end cap.

MAINTENANCE



Crosscut Knife Spindle Assembly

REPAIR TOLERANCE CHARTS

7, 8, 10, 12, 14 and 16 Knife Spindles

Part Name	What to Check	Replace if:
Shaft	 Diameter in several places	Less than .998" (25.35 mm)
Bearing Blocks	 Diameter of center bushing	More than 1.0033" (25.484 mm)
	 Diameter of crank & idler pin holes	More than .3757" (9.543 mm) on any hole
Crank Bearing Block	 Diameter of crank pin holes	More than .3757" (9.543 mm) on any hole
	 Diameter of center bore	More than 1.9412" (49.306 mm)
Eccentric than	 Outside diameter	Less than 1.9352" (49.154 mm) or more .002" (.05 mm) out of round
Crank Pins & Idler Pins	 Diameter in several places	Less than .372" (9.45 mm)
Knife Screws	 Inspect nylon insert	Screw can be turned by hand
Gear	Inspect for wear or damage	Broken or badly worn teeth

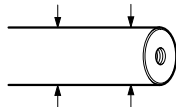
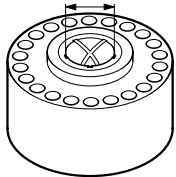
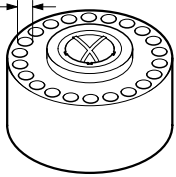
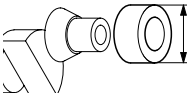
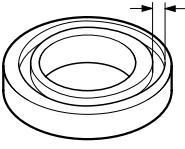
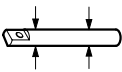
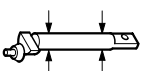
22 Knife Spindle

Part Name	What to Check	Replace if:
Shaft	 Diameter in several places	Less than .998" (25.35 mm)
Bearing Blocks	 Diameter of center bushing	More than 1.0033" (25.484 mm)
	 Diameter of crank & idler pin holes	More than .3222" (8.184 mm) on any hole
Crank Roller	 Outside diameter	Less than .370" (9.40 mm)
Cam	 Width of groove at several places	Wider than .381" (9.68 mm)
Idler Pins	 Diameter in several places	Less than .3180" (8.077 mm)
Crank Pins	 Diameter in several places	Less than .3180" (8.077 mm)
Knife Screws	 Inspect nylon insert	Screw can be turned by hand
Gear	Inspect for wear or damage	Broken or badly worn teeth

MAINTENANCE

Crosscut Knife Spindle Assembly

REASSEMBLY

(7, 8, 10, 12, 14 & 16 knife spindles)

Refer to Figure 42 below.

1. **Clamp spindle in soft jaw vise** with threaded end down.
2. **Lubricate idler pins** and insert in bearing block.
3. **Grease center hole** of gear and bearing block. Fasten drive cap to spindle; then fasten gear to drive cap.
4. **Reverse the spindle** in vise. Lubricate crank pins and insert thru bearing block.
5. **Grease all holes** then place crank bearing block over crank pins.

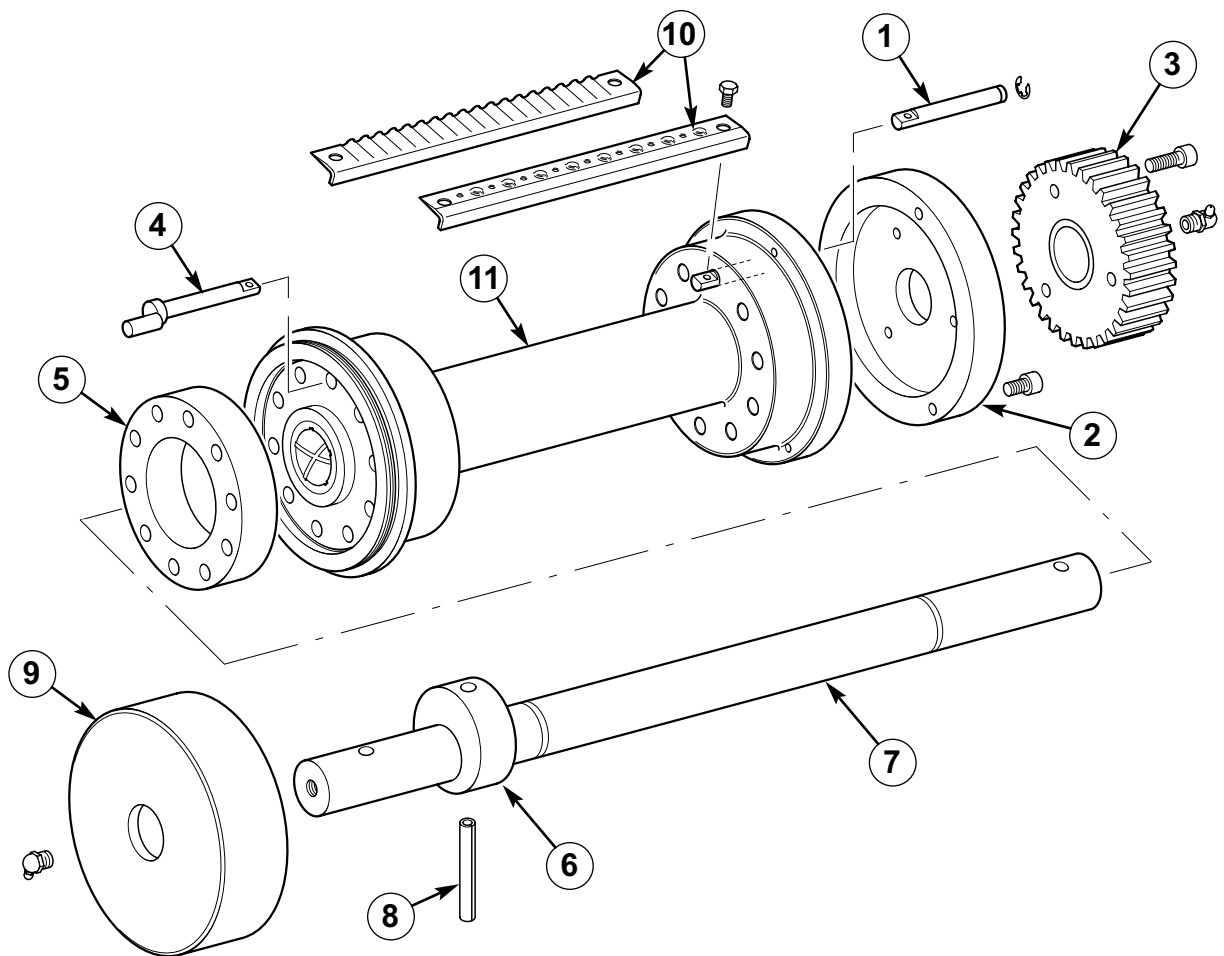

Figure 42 — Crosscut spindle assembly: 7, 8, 10, 12, 14 and 16 knives. (1) Idler Pin, (2) Drive Cap, (3) Gear, (4) Crank Pins, (5) Crank Bearing Block, (6) Eccentric, (7) Shaft, (8) Spring Pin, (9) End Cap, (10) Knife, (11) Spindle.

6. **Fasten eccentric to shaft** with spring pin. The side marked “OUTSIDE” should face short end of shaft (Figure 43). Drive spring pin thru narrow side of eccentric until slightly recessed.

NOTE: *Small particles of metal will be shaved off of spring pin as it is driven into the eccentric. Clean the spring pin and shaft bore thoroughly before continuing the assembly procedure.*

7. **Grease outer perimeter of eccentric** and grooves on shaft. Slide shaft with eccentric thru spindle until eccentric is in crank bearing block. *Rotate shaft to make sure parts do not bind.*
8. **Grease the threads of the end cap** and tighten on spindle with a chain wrench.
9. **Install knives:** (Spindle in “V” block supports and gear on your left.) Fasten knives to flat portion of idler and crank pins so *knife edge is toward you*. Tighten screws, then back off a quarter turn. Rotate spindle to seat knives in place. Mark a starting point on the spindle, then tighten screws the rest of the way.
NOTE: *Overtightening screws will bow knives.*
10. **Install grease fittings** in shaft so they point in the opposite direction of the knife edges. If grease fittings are installed incorrectly, spindle cannot be lubricated with dicing unit in operating position.
11. **Lubricate spindle** with Haynes Lubri-film (see “Lubrication”, page 29).

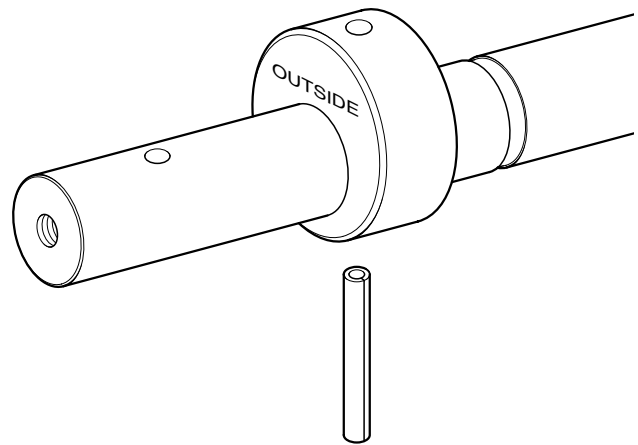

Figure 43 — Proper orientation of eccentric and insertion of spring pin.

MAINTENANCE

Crosscut Knife Spindle Assembly

REASSEMBLY (22 knife spindle)

Refer to Figure 44.

1. **Clamp spindle in soft jaw vise** with threaded end down.
2. **Grease center hole** of gear and bearing block. Fasten drive cap to spindle; then fasten gear to drive cap.
3. **Reverse the spindle in vise.** Lubricate crank pins and insert thru bearing block. Grease the ends of the crank pins and install rollers. Align the crank pins as shown in Figure 45, page 47.
4. **Fasten cam hub** to shaft with spring pin. Orient the shaft as shown in Figure 44 with five holes facing up. Drive spring pin in until slightly recessed into cam hub.

NOTE: *Small particles of metal will be shaved off of spring pin as it is driven into the cam hub. Clean the spring pin and shaft bore thoroughly before continuing the assembly procedure.*

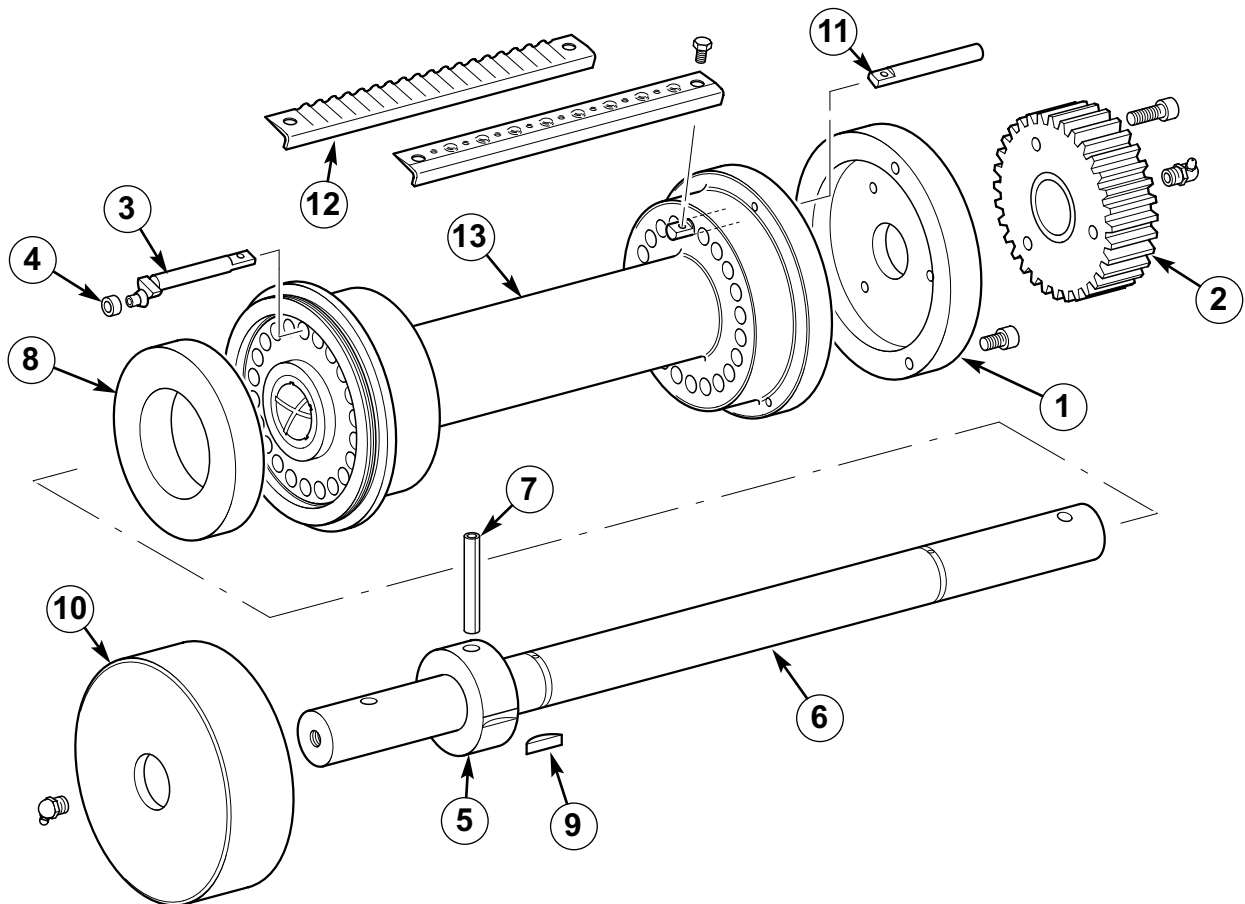

Figure 44 — Crosscut spindle assembly: 22 knives. (1) Drive Cap, (2) Gear, (3) Crank Pin, (4) Roller, (5) Cam Hub, (6) Shaft, (7) Spring Pin, (8) Cam, (9) Woodruff Key, (10) End Cap, (11) Idler Pin, (12) Knife, (13) Spindle.

MAINTENANCE

Crosscut Knife Spindle Assembly

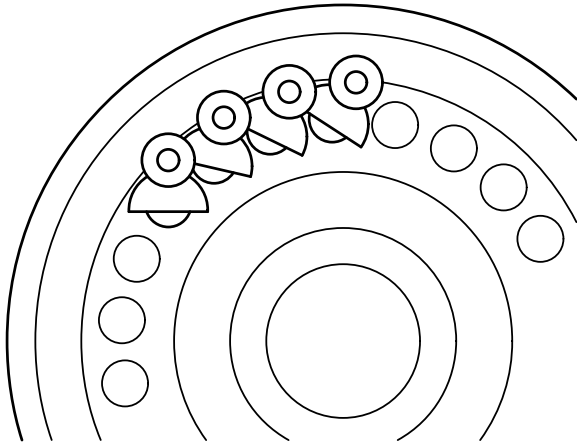

Figure 45 — Proper alignment of crank pins.

5. **Grease outer perimeter of cam hub** and grooves on the shaft. Slide the shaft with cam hub into the bearing block and spindle.
 6. **Install cam** then push rollers inward until they touch the center portion of the cam, allowing the cam to drop down and enclose the rollers.
 7. **Pull the shaft out far enough** to align the keyways on the cam hub and shaft; then insert woodruff key. Push shaft back into the spindle.
 8. **Grease the threads of the end cap** and tighten on spindle with chain wrench.
 9. **Remove spindle from vise** and place in “V” block supports with gear on your left. Lubricate idler pins and insert in spindle.
 10. **Install knives:** (Spindle in “V” block supports and gear on your left.) Fasten knives to flat portion of idler and crank pins so *knife edge is toward you*. The knife screws go into the side with the recessed threads. Tighten screws, then back off a quarter turn. Rotate spindle to seat knives in place. Mark a starting point on the spindle, then tighten screws the rest of the way.
- NOTE:** *Overtightening screws will bow knives.*
11. **Install grease fittings in shaft** so they point down when the shaft locating hole is pointing down. If grease fittings are installed incorrectly, spindle cannot be lubricated with dicing unit in operating position.
 12. **Lubricate spindle** with Haynes Lubri-film (see “Lubrication”, page 29).

MAINTENANCE

Crosscut Knife Spindle Assembly

BEARING BLOCK REPLACEMENT

NOTE: *Urschel Laboratories urges all customers to return crosscut knife spindles in need of bearing block replacement to the factory for these reasons:*

1. Our repair department is equipped with fixtures and equipment specially built for this purpose.
2. Further damage can occur if the procedure is not done correctly. This is costly to the customer.
3. Potentially reusable parts must be examined and measured. Proper procedures must be followed or the repair will not be successful and the spindle will fail again prematurely.
4. Our personnel use their knowledge and experience to not only repair, but also determine when possible the cause for failure. The customer can then make adjustments in operation to avoid future problems.

If your maintenance department has the skill and equipment and your company wishes to repair crosscut spindles, the following tools are recommended:

1. Vise
2. Arbor press
3. Dial indicator
4. Surface plate
5. Small hole gauges
6. Micrometers (0-1" & 1-2")
7. Telescoping gauges
8. Propane torch
9. "V" block support
10. Pin punch
11. Depth micrometer (0-1")
12. Special tools available from Urschel Laboratories, see Tools, page 69.

MAINTENANCE

Crosscut Knife Spindle Assembly

DISASSEMBLY

1. **Remove crosscut knife spindle from dicing unit.** See “Disassembly”, page 36. Disassemble spindle (see “Disassembly”, page 40).
2. **If bearing blocks need to be replaced** (see “Inspection”, page 42), use tap to thread two (2) opposing holes in each bearing block, 3/8-16 for the 22 knife blocks and 7/16-14 for all other blocks.
3. **Using the tapped set of holes,** attach the pusher block to one of the bearing blocks (Figure 46).
4. **Position the spindle,** with the pusher block down, onto the support tube on the table of the arbor press.
5. **Slide the spindle shaft down thru the spindle** to contact the pusher block (Figure 47).

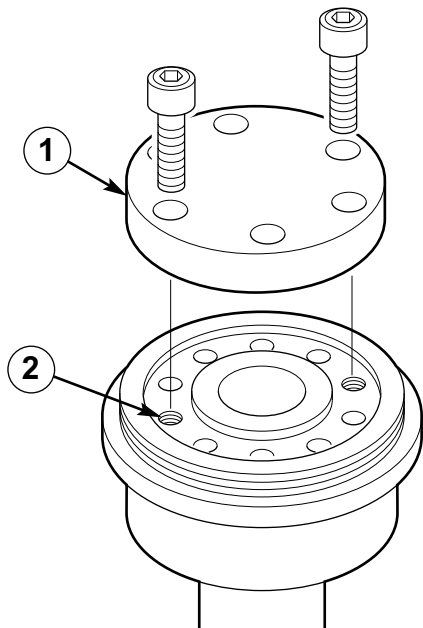

Figure 46— Attach pusher block to bearing block. (1) Pusher Block, (2) Tapped Hole.

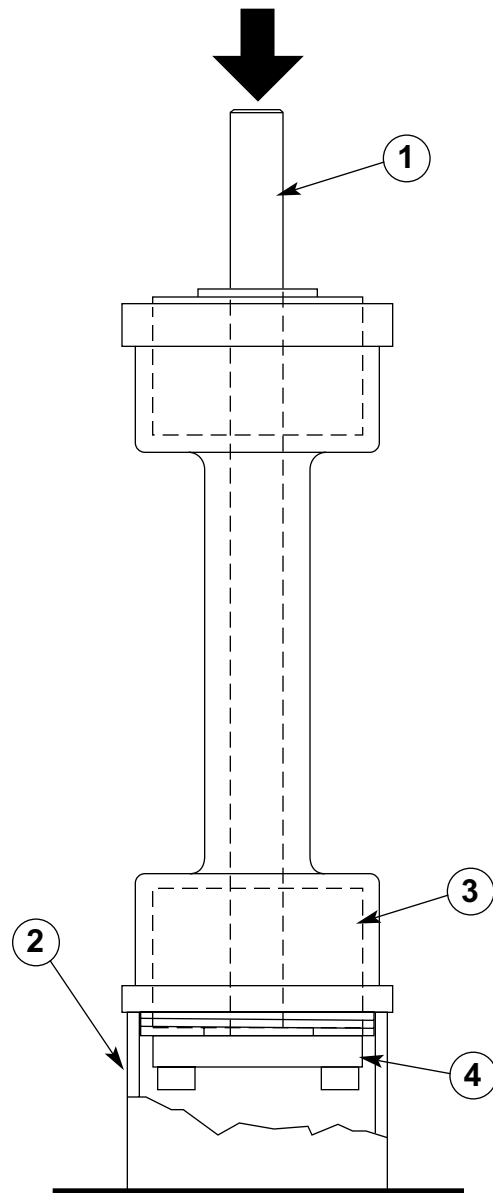

Figure 47— Press bearing block out of spindle. (1) Spindle Shaft, (2) Support Tube, (3) Bearing Block, (4) Pusher Block.

6. **Press bearing block out of spindle.**
7. **Repeat steps 2 thru 6** for the other end of spindle.

MAINTENANCE

Crosscut Knife Spindle Assembly

INSPECTION

All parts should be inspected for serviceability and repaired or replaced if necessary.

Spindle: Bearing blocks must fit tight. If old blocks are loose or new block slides freely into bore, spindle is scrap and must be replaced. Check for nicks or burrs. Hone if necessary. Check small holes for excessive wear; the large end of an installation pin (see Tools, page 69) can be used as a gauge. Pin must go into hole freely with no more than .015" (.38 mm) clearance. Oversize holes may not affect spindle performance, but can affect proper bearing block installation.

Using a surface plate and dial indicator, check the ends of the spindle for parallelism. If more than .002" (.05 mm) out of parallel, spindle must be straightened or replaced. A bent spindle should be sent to Urschel Laboratories repair department for inspection and evaluation.

MAINTENANCE

Crosscut Knife Spindle Assembly

REASSEMBLY

1. **Remove any burrs or nicks** from the bearing blocks and the mating surfaces in the spindle.
2. **Insert three (3) installation pins** into three (3) somewhat evenly spaced holes in bearing block. Snug nuts just to retain pins.
3. **Set spindle on smooth flat surface** with threaded end down. Set bearing block, complete with installation pins onto spindle so that ends of installation pins are set in holes in spindle.
4. **Rotate spindle slowly by hand** while applying heat with a propane torch 1" (25 mm) below top of spindle (Figure 48). Spindle will expand from heat and bearing block will drop in. Remove heat.
5. **Use handle of screwdriver to apply downward pressure** on bearing block for at least one minute.
6. **If bearing block does not drop in** after applying heat for one minute, press down on bearing block with the handle of a screwdriver after bearing block starts to sweat oil.
7. **Carefully remove installation pins** (may be hot). Check with a .0015" (.0381 mm) feeler gauge through the pin holes to make sure bearing block is seated properly (Figure 49). Gauge should not slip between parts.

If bearing block starts to drop in, but does not seat properly, allow spindle to cool, remove bearing block, check parts for nicks and burrs and repeat procedure.

(Reassembly continued on page 52.)

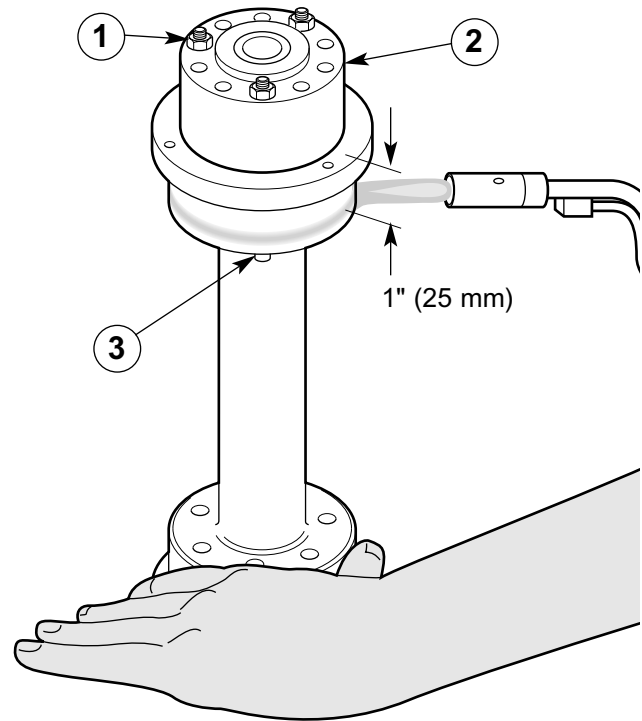

Figure 48 — Installing bearing block. (1) Nut, (2) Bearing Block, (3) Installation Pin.

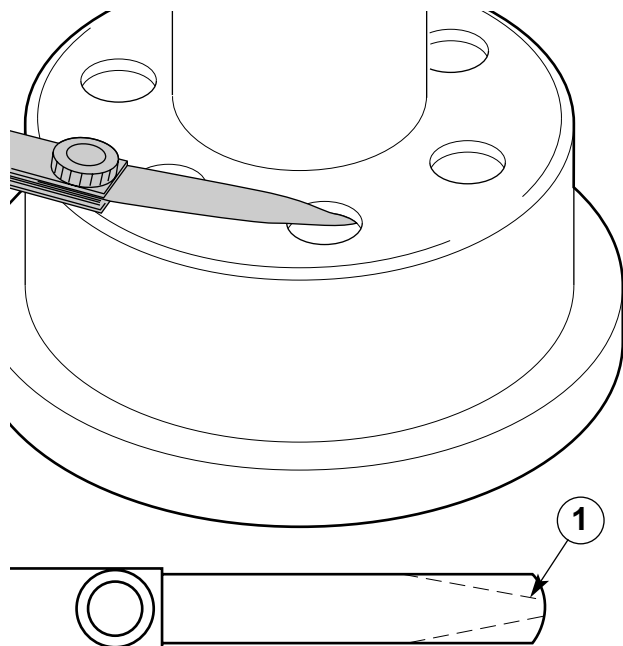

Figure 49 — Checking bearing block seat. Trim .0015" feeler gauge so that it may be inserted into hole. (1) Trim Lines.

MAINTENANCE

Crosscut Knife Spindle Assembly

REASSEMBLY (continued)

8. **Turn spindle over and insert installation rods** into three (3) somewhat evenly spaced holes.
9. **Slide second bearing block** onto installation rods until bearing block rests on top of spindle.
10. **Rotate spindle slowly by hand** while applying heat with a propane torch 1-1/4" (32 mm) below top of spindle (Figure 50). Spindle will expand from heat and bearing block will drop in. Remove heat.
11. **Use handle of screwdriver to apply downward pressure** on bearing block for at least one minute.
12. **If bearing block does not drop in** after applying heat for one minute, press down on bearing block with the handle of a screwdriver after bearing block starts to sweat oil.
13. **Carefully remove installation rods** (may be hot). Check with a .0015" (.0381 mm) feeler gauge through the pin holes to make sure bearing block is seated properly (see Figure 49, page 51). Gauge should not slip between parts.

If bearing block starts to drop in, but does not seat properly, allow spindle to cool, remove bearing block, check parts for nicks and burrs and repeat procedure.

To complete the assembly of 7, 8, 10, 12, 14 and 16 knife spindles, see page 44.

To complete the assembly of 22 knife spindle, see page 46.

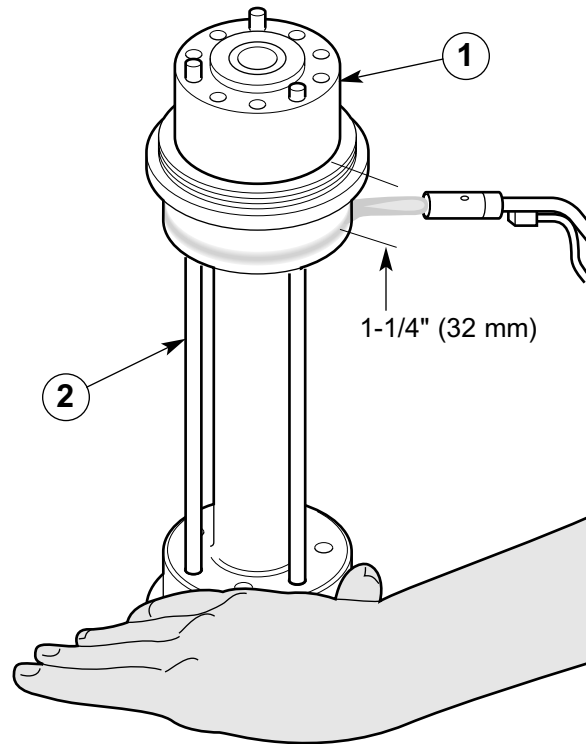

MAINTENANCE

Circular Knife Spindle Assembly



Figure 51 — Using spindle wrench to remove the spindle nut.

DISASSEMBLY

1. **Remove circular knife spindle.** See Dicing Unit, “Disassembly”, page 36.
2. **Clamp spindle in a soft jaw vise** at gear end. (Soft jaws are necessary to protect the precision parts.) *Do not clamp vise onto gear.*
3. **Use spindle wrench** to remove nut, turning counterclockwise. Carefully slide knives and spacers off spindle (Figure 51).

INSPECTION

All parts should be inspected for serviceability and repaired or replaced if necessary. For information on knife care and sharpening, see page 60 and refer to the “SHARP” bulletin provided with machine.

Spacers and Shaft: Check for burrs and hone if necessary, but be careful to remove *only the burr*.

Spindle: Check for burrs and hone if necessary, but be careful to remove *only the burr*. Inspect thrust sleeves for wear and replace if necessary (see “Reassembly”, page 54).

Gear: Inspect gear for wear or damage. Replace if necessary.

Knives: Replace any that are bent or have large nicks. Knives should also be replaced if the diameter is less than 3.938" (100 mm) or the serrations are no longer present. See page 60 for more information on knife care.

MAINTENANCE

Circular Knife Spindle Assembly

REASSEMBLY

1. **Replace thrust sleeves if necessary.** Remove worn sleeves by prying out with a screwdriver (Figure 52). Replace pins if they are damaged or worn and tap in new sleeves.
2. **Alternate knives and spacers** on the spindle, beginning with a knife. Serrations on knives must face the same direction (Figure 53).
3. **Replace nut on spindle** and tighten securely. Install spindle on machine or carefully set aside on knife edges, bracing it to prevent it from rolling.

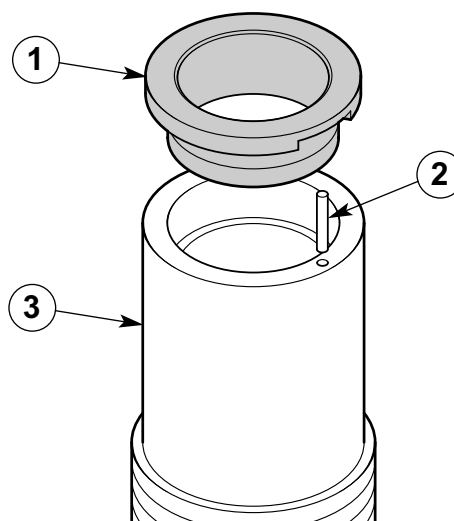

Figure 52 — Replacing thrust sleeve. (1) Thrust Sleeve, (2) Pin, (3) Spindle.

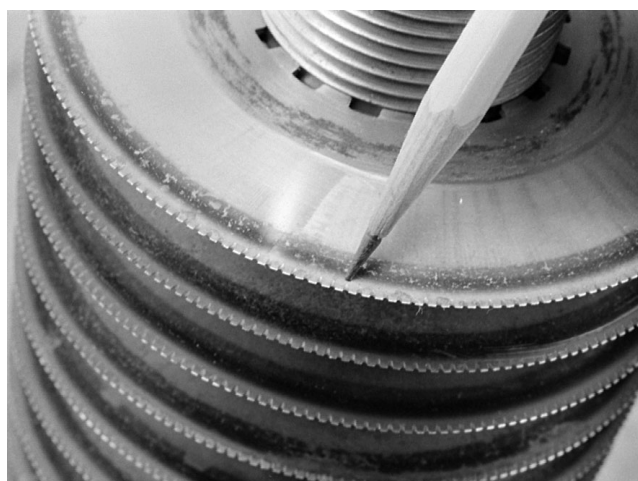

Figure 53 — Make sure serrations face the same direction.

DISASSEMBLY

In the event of any bearing failure, all bearings in the drive train should be replaced at the same time. This insures maximum performance and saves on maintenance time in the future.

Before proceeding with disassembly, disconnect and lock out power source. Remove all covers and guards and swing dicing unit into maintenance position. Remove the impeller, slice case and drive belts. See Slicing Unit, "Disassembly", page 32.

1. **Loosen the two set screws** in gear hub on main drive shaft (Figure 54). Use a hammer and a brass rod approximately 3/4" x 12" (19 x 305 mm) to drive shaft out

of gear assembly. Do not allow gear or thrust washer to drop as shaft is removed.

2. **Slide shaft back into position**, meshing the small gear on drive shaft and the gear on jack shaft. Hold drive pulley to prevent rotation when loosening the fastener that holds retaining washer to jack shaft; remove retaining washer.

3. **Remove drive pulley and key.** Remove cap screw from small gear on drive shaft, then slide gear and thrust washer off shaft.

(Disassembly continued on page 56)

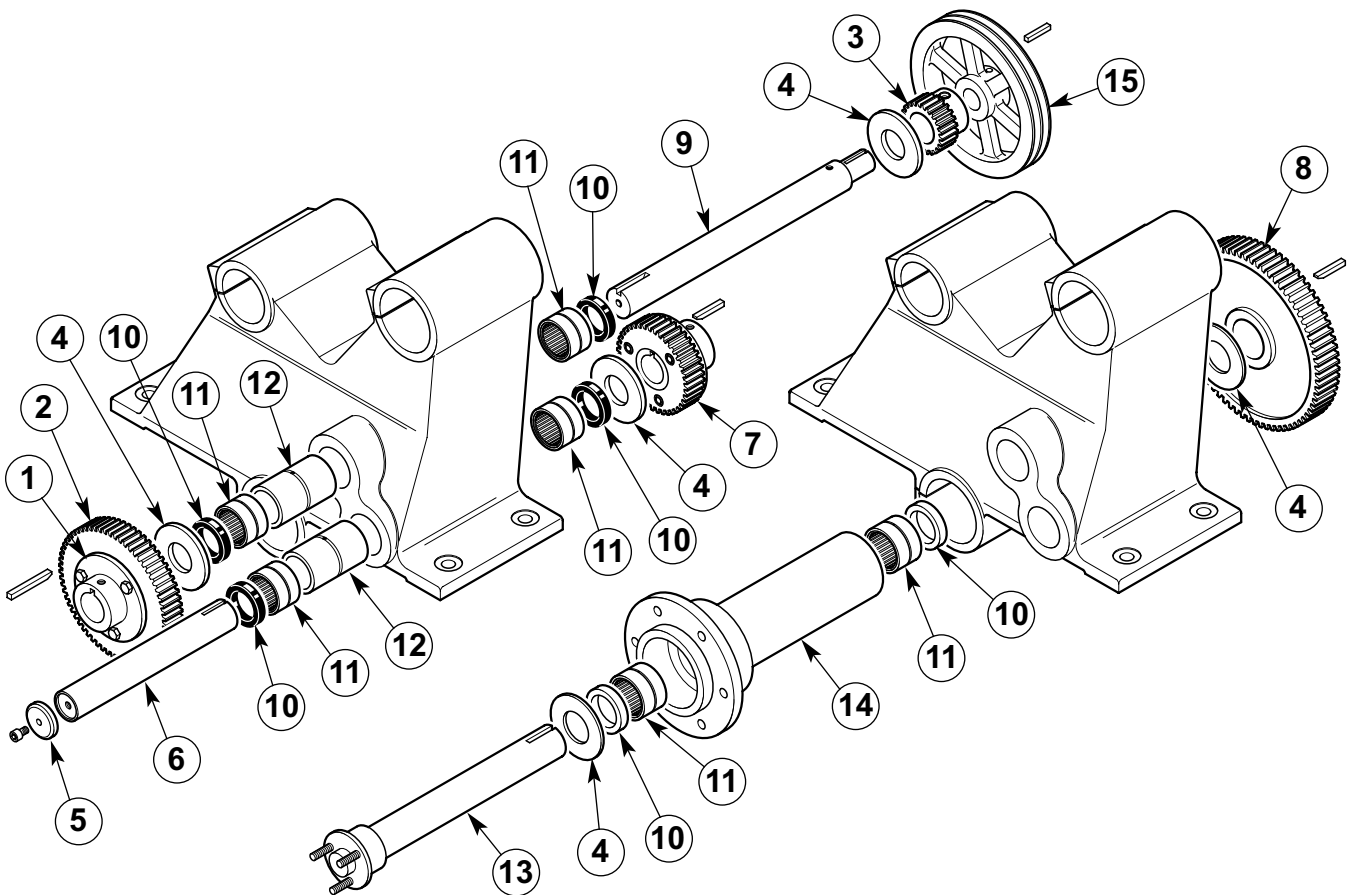

Figure 54 — Drive Train. (1) Gear Hub, (2) Gear, Main Drive Shaft, (3) Small Gear, Main Drive Shaft, (4) Thrust Washer, (5) Retaining Washer, (6) Jack Shaft, (7) Gear, Jack Shaft, (8) Gear, Impeller Shaft, (9) Main Drive Shaft, (10) Oil Seal, (11) Roller Bearings, (12) Bearing Spacer, (13) Impeller Shaft, (14) Bearing Housing, (15) Drive Pulley.

MAINTENANCE

Drive Train

DISASSEMBLY (continued)

4. **Pull main drive shaft from main support casting.** Remove oil seals from each side of main support casting and discard.
5. **Loosen two set screws** in gear hub on jack shaft then remove gear, key and thrust washer.
6. **Remove jack shaft** from main support casting.
7. **Remove oil seals** from each side of casting and discard.
8. **Loosen the two set screws** in gear hub on impeller shaft; remove gear and key.
9. **Remove thrust washer.** Pull impeller shaft with thrust washer out of bearing housing from impeller end.

NOTE: *At this point, remaining disassembly can be done with bearing housing left in main support casting or bearing housing can be removed for bench disassembly. To remove, loosen the two pinch bolts under the main casting and remove grease hose from impeller bearing housing.*

10. **Remove oil seals** from each side of bearing housing and discard.
11. **Remove all roller bearings** and bearing spacers. Slide or drive bearings out using a soft brass rod.

INSPECTION

All parts should be inspected for serviceability and repaired or replaced if necessary.

Cleaning: Wash all parts thoroughly in a suitable de-greasing solution. Clean holes in casting to remove remaining grease or foreign matter.

Bearings: Inspect and discard if there is rust, scoring or flat spots on rollers. *Install new bearings if there is any doubt about serviceability.*

Shafts: Inspect for rust, pits and deep scoring in areas of oil seal contact. Remove any burrs from ends of shafts. Bearing areas must be smooth. Install new shaft if diameter measures less than 1.375" (34.925 mm) for main drive shaft and jack shaft, less than 1.4985" (38.0619 mm) for impeller shaft or if measurement indicates tapering wear or flat spots.

Bearing spacer: Replace if severely rusted or if ends are scored and worn.

REASSEMBLY

1. **Lubricate and install bearing spacers** and bearings for main drive shaft and jack shaft.
2. **Lubricate interior surfaces of bearing housing.** Lubricate and install bearings in housing, pushing in until they reach machined seat.
3. **Install new oil seals** for main drive shaft and jack shaft. Install seals with spring facing outward. Gently tap the seals with a plastic hammer until they are recessed approximately 1/16" (1.6 mm).

4. **Install new oil seals** into bearing housing with leather lip facing out. Gently tap seals with a plastic hammer until they are recessed approximately 1/16" (1.6 mm).
5. **Install jack shaft.** Lubricate shaft and use care when inserting to prevent turning seal lip inward. Avoid twisting or forcing the shaft into the bearings.
6. **Install retaining washer** on jack shaft and tighten cap screw securely. Slide thrust washer onto shaft.
7. **Install gear** with key onto jack shaft. Use a feeler gauge to set a .004" (.102 mm) clearance between gear and thrust washer (Figure 55). Tighten set screws.
8. **Lubricate and install main drive shaft** using the same precautions as in step 5.
9. **Slide thrust washers** onto main drive shaft; then install small gear with cap screw and tighten securely. Torque fastener to 45-50 foot pounds (61-68 Newton meters).
10. **Install remaining gear** with key onto drive shaft. Use a feeler gauge to set a .004" (.102 mm) clearance between gear and thrust washer. Tighten set screws securely.
11. **Install bearing housing**, if removed. Install grease hose thru casting into housing. Tighten the two pinch bolts.
12. **Place thrust washer** on impeller shaft, then slide shaft into bearing housing. Lubricate shaft and use care when inserting to prevent turning seal lip inward. Avoid twisting or forcing the shaft into bearings. Install remaining thrust washer.

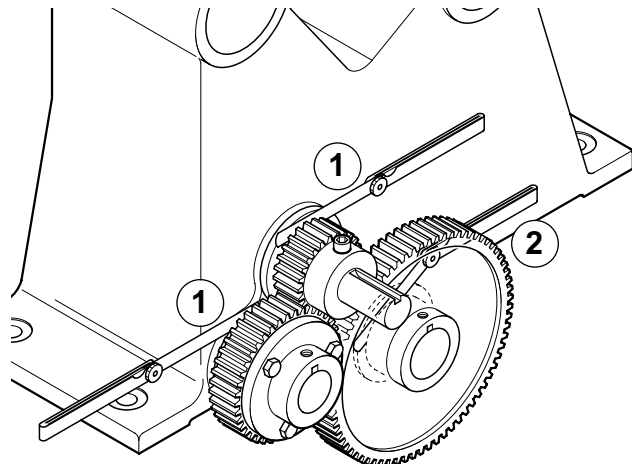

Figure 55 — Use a feeler gauge to set clearance between gears and thrust washers. (1) .004" (.102mm), (2) .007" (.178mm).

13. **Install slice case, impeller and gear** with key. Use a feeler gauge to set .007" (.178 mm) clearance between thrust washer and gear.
14. **Install drive pulley** and key. Use a straight edge to align pulley with motor pulley; tighten set screws.
15. **Lubricate thru the three fittings** located on the frame until grease appears around the thrust washers.
16. **Reassemble slicing unit** (see "Reassembly", page 33) and replace drive belts. If the bearing housing was removed, the slice case will need adjustment (see "Adjustments", page 34). Replace covers and guards.

INSPECTION

⚠ WARNING: *In the event of an electrical problem, only a qualified electrician should inspect or repair the fault. Voltages dangerous to life exist in the starter enclosure! Always disconnect and lock out power source before beginning electrical inspection or repair.*

The electrical assembly must be in good working condition before operating this machine. For a description of amplifier and safety switch operation and method for checking this system, see page 22. Electrical schematics are located in the starter enclosure and on pages 94 and 95. Refer to Figures 56 or 57 and inspect the following items in the electrical assembly:

Starter enclosure: Inspect interior of starter enclosure for moisture and corrosion. Check gasket around door and window. Breather drain should be free from obstruction. Inspect “O” (STOP) and “I” (START) push button assemblies and pilot light assembly for damage or corrosion. Replace rubber boots and pilot light lens if damaged.

Fuses: Remove main fuses and transformer fuses. (Transformer fuses in the IEC enclosure are located in fuse blocks on the DIN bar.) Check with an ohmmeter or continuity light. If one fuse is replaced, all others of that type fuse should also be replaced. Remove and inspect amplifier fuses (Figure 58, page 59). Replace if necessary.

Heaters (NEMA enclosure): If heaters (thermal overloads) have been tripped several times they may fail to reset. If one heater fails, all heaters in that starter should be replaced. Check for proper motor current draw if heaters continue to trip.

Starter coil (NEMA enclosure): Disconnect leads from coil at front of motor starter and check with an ohmmeter. Replace if necessary

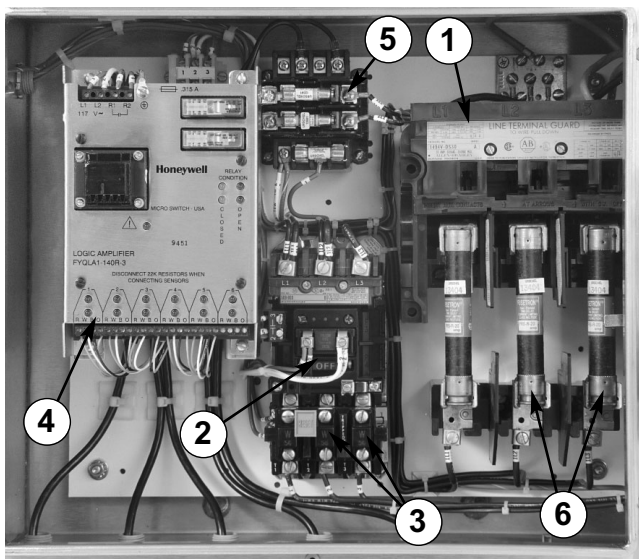

Figure 56 — Typical starter enclosure interior (NEMA). (1) Disconnect, (2) Starter Coil, (3) Heaters, (4) Amplifier, (5) Transformer, (6) Main Fuses.

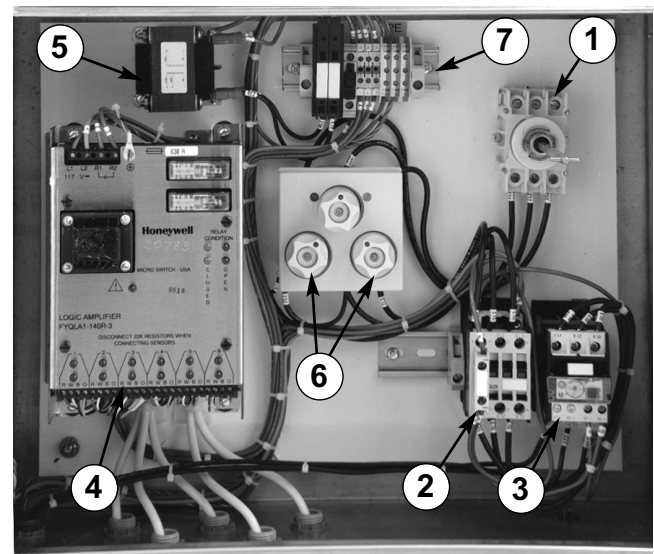

Figure 57 — Typical starter enclosure interior (IEC). (1) Disconnect, (2) Contactor, (3) Overload Block, (4) Amplifier, (5) Transformer, (6) Main Fuses, (7) DIN Bar.

Contactor (IEC enclosure): Disconnect leads from coil on top of contactor and check with an ohmmeter. Replace coil or contactor if necessary.

Overload Block (IEC enclosure): If overload block has been tripped several times, it may fail to reset and must be replaced. Check for proper motor current draw if overload block continues to trip.

Amplifier: The amplifier and safety switches incorporate self-diagnostic features to help identify the source of problems. The LEDs on the amplifier (Figure 58) will indicate the status of the system:

⚠ WARNING: *The amplifier must be properly wired to function correctly. Consult the manufacturer's literature for complete wiring instructions.*

Both green “relay condition” LEDs are illuminated: all circuits are closed and machine is ready for operation.

Red “relay condition” LEDs and any of the red “switch output” LEDs are illuminated: the circuit for the sensor or resistor assigned to that location is open. If the sensor and actuator are aligned and within specified sensing distance, the sensor or resistor has failed and must be replaced.

Both red “relay condition” LEDs are illuminated and the red “attention” LED is flashing: the amplifier has detected a fault. Inspect the condition and placement of sensor leads and resistors. Terminals should be tight and free from corrosion. With sensors and actuators aligned and

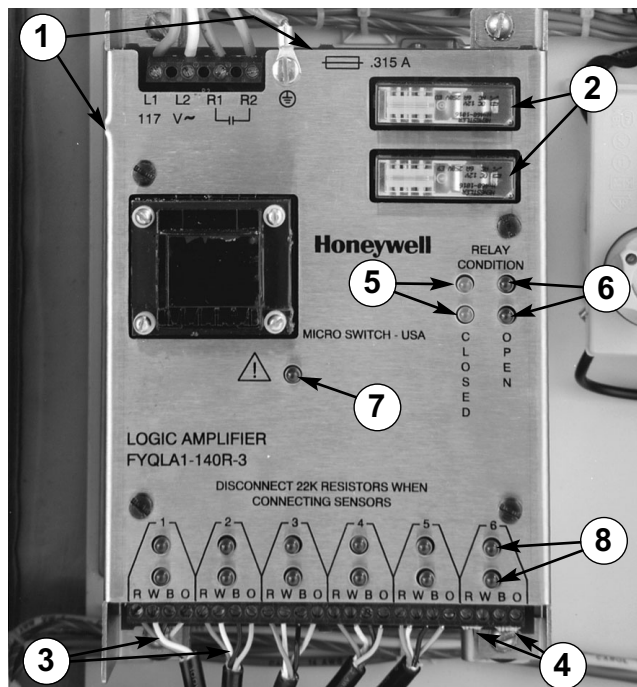

Figure 58— Amplifier. (1) Fuses, (2) Relays, (3) Sensor Leads, (4) Resistors, (5) Green “Relay Condition” LEDs, (6) Red “Relay Condition” LEDs, (7) Red “Attention” LED, (8) Red “Switch Output” LEDs.

within specified sensing distance, reset the system by turning the power disconnect switch to “O” (OFF) and then turning the power disconnect back to “I” (ON). If all items are in good condition and red “attention” LED is still flashing, the amplifier has failed and must be replaced.

⚠ WARNING: *Always perform the pre-start safety switch test before operating the machine. See “Safety Switches”, page 22.*

NOTE: *An exchange program is available should the amplifier need replacement; contact Urschel Laboratories for complete information.*

MAINTENANCE

Knife Care

KNIFE CARE GUIDELINES

Knives should be inspected and sharpened or replaced at regular intervals depending upon operating conditions, type of product and hours of operation. Follow these guidelines for best results:

- DO NOT attempt to remove all defects from the knife edge by sharpening.** This practice results in shortened knife life. Small defects will not affect knife performance.
- Maximum metal removal through sharpening should not exceed recommended limits** (see chart). If excessive metal is removed, knives become more blunt making sharpening difficult and reducing cutting efficiency. Serrations also become shallower and knives may not pull product through the machine as effectively. Narrow crosscut knives and undersize circular knives will often cause incomplete cuts, resulting in cubes or strips which are attached to each other. See chart for recommended minimum dimensions. Some users may be able to continue sharpening knives longer if the quality of cuts remains acceptable.
- New knives should not be installed beside worn knives.** This arrangement may result in poorly shaped strips or cubes. Keep all the knives from one spindle in a set and sharpen them together. Periodically check knife width or diameter to make sure all the knives in a set are the same size.

SHARPENING EQUIPMENT

Urschel Laboratories manufactures machines to quickly and efficiently sharpen knives. The Model CKG honing machine is used to place the best possible edge on circular knives. The Model WG honing machine is

used to sharpen slicing and crosscut knives (straight cut only). See the "SHARP" bulletin or contact Urschel Laboratories for additional information.

RECOMMENDED MINIMUM DIMENSIONS

The following minimum dimensions are intended to give satisfactory results for most applications. However, each customer must look at the quality of cut on his product to determine at what point knives are resharpened beyond usefulness. The minimum dimensions stated are intended to give satisfactory results for most applications. Some customers may be able to get satisfactory results from knives ground smaller, but some may notice a deterioration in quality of cut before the minimum size is reached.

Type of Knife	Knife No.	Minimum Size
SLICING	13104	3.187" (80.95 mm)
	13245	3.187" (80.95 mm)
	25030	3.187" (80.95 mm)
CROSSCUT*	12283	.088" (2.24 mm)
	12462	.088" (2.24 mm)
	13144	.126" (3.20 mm)
	13246	.126" (3.20 mm)
CIRCULAR (serrated)	12281	bottom of serrations
	12686	bottom of serrations
	16181	bottom of serrations
	17342	bottom of serrations
	13638	bottom of serrations
	(non-serrated)	12282

* Minimum dimension is measured from edge of holes to knife edge at center of knife.

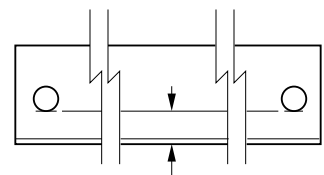

BUFFING

⚠ WARNING! *Only qualified trained personnel should buff knives. Use adequate eye and respiratory protection, and a properly guarded buffing wheel. Hold knife securely; the use of a knife holding clamp is recommended. Never attempt to catch a dropped knife! Should you drop a knife during the buffing operation, move away and let it fall.*

When slicing or crosscut knives are sharpened by grinding, filing or honing, a slight wire edge may be produced. Buffing will remove this wire edge.

Install two to four 10" (254mm) diameter buffing wheels side by side between flanges at least 2" (50 mm) in diameter. Buffing wheels and bars of buffing compound are available from Urschel Laboratories, see "Tools", page 69. Turn on the buffer (3600 RPM) and hold the bar of buffing compound firmly against the edge of the buffing wheels to apply a light coating of compound. Apply compound frequently to obtain sharp edges quickly.

NOTE: *If excess compound is applied, the wheel will harden, making it ineffective. Should this occur, use a buffing wheel rake, available from an industrial supplier, to soften the wheel.*

For safety reasons, use a knife holding clamp for crosscut knives (see "Tools", page 69). Slicing knives can be hand held; be cautious and use a firm grip. Hold the knife or knife clamp firmly with the bevel side up, parallel with and just below the center line of the shaft of the buffer (Figure 59). Push the knife edge into the buffing wheel, penetrating the wheel 1/16"-1/8" (1.5-3 mm). Move the knife endwise and buff the entire edge. Do not hold the knife in one area of the buffing wheel too long as the edge may heat and burn.

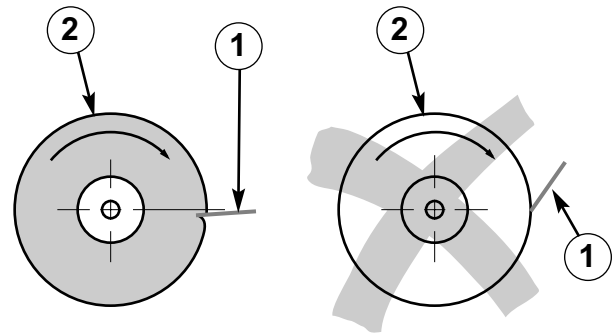

Figure 59 — Correct position for knife during buffing. (1) Knife, (2) Buffing Wheel.

Move the edge across the buffing wheel with a steady rapid movement in each direction. Several rapid passes are better than one or two slow ones. If a burr or wire edge remains, turn the knife over and buff with the bevel side down. Continue buffing, switching from side to side, until wire edge or burr is gone.

Sharpen all sides of crinkle knife edges by tipping the knife endwise at a slight angle, first in one direction and then in the other. Next, the knife is held straight and level to buff the top and bottom of the crinkles.

Failure to obtain sharp edges by buffing may be caused by the following:

1. Edges may be too dull or blunt. Blunt edges must always be ground or filed to restore a bevel width and angle similar to that found on a new knife.
2. Knives must be correctly held against the buffing wheel (Figure 59).
3. Too little or too much buffing compound on the wheel.
4. Undersize buffing wheels. Discard the buffing wheels when they are worn to 8-3/4" (222 mm) diameter.

MAINTENANCE

Troubleshooting

PROBLEM	CAUSE	CORRECTION
Incomplete Cuts	Circular or crosscut knives undersized from sharpening	Replace knives as required. Avoid using undersized and new knives together.
	Wrong slicing knife	See "Slicing Unit", pages 73 & 75.
	Slice case out of adjustment	Adjust slice case. See "Adjustments", page 34.
Crushed Product	Excessive slice thickness	Adjust slice thickness. See "Sizes of Cuts", page 16.
	Dull knives	Sharpen or replace knives as required.
	Wrong gate extension strip	See "Slicing Unit", pages 73 & 75.
Diamond Shaped Dices	Crosscut knives not vertical when contacting product	Check projection of location pin in left side frame. Pin should project 1/4" (6 mm). See Figure 33, page 38.
	Product releasing unevenly from crosscut knives	Use additional water during processing. Certain products can also be blanched to improve the cut.
Irregular Chattering Sound	Backlash in gears	Check for worn or broken gears and replace. Rapid gear wear can be caused by worn bearings and/or shafts. Check for obvious looseness when installing new gears.
	Inadequate lubrication of thrust washers	See "Lubrication", page 29.

MAINTENANCE

Troubleshooting

PROBLEM	CAUSE	CORRECTION
Harsh, Metallic Grinding Sound	Impeller rubbing against slicing knife holder or slice case	Inspect for loose impeller nuts. Replace if they can be turned by hand. Inspect for worn impeller shaft and/or bearings. Replace as required. See "Drive Train", pages 55 — 57. Check for bent or damaged slicing knife holder. See "Slicing Unit", page 33.
	Circular knives rubbing against slicing knife holder	Check that circular knives are centered in slots of slicing knife holder and adjust as required. See "Adjustments", page 39. Check for worn bearings on spindle shaft. See "Inspection", page 37. Check that knives clear bottom of slots in slicing knife holder. Adjust slice case as required. See "Adjustments", page 34.
	Circular knives rubbing against stripper plate	Adjust stripper plate so knives are centered in slots. See "Adjustments", page 39.
	Worn motor bearings	Run motor with belts removed to verify. Replace bearings. Consult motor manufacturer.
Regular or Intermittent Clicking Sound	Crosscut knives striking slicing knife or knife holder	Check for bent or twisted knives and replace as required. Check for bent slicing knife holder and/or product build-up on mounting surface. Replace and/or clean as required. See "Slicing Unit", page 32. Check adjustment of slice case with gauge and adjust as required. See "Adjustments", page 34.
	Crosscut knives striking circular knives (22 knife spindle)	Check for excessive wear in crosscut knife spindle. Repair as required. See "Inspection", page 37. Check for knives installed incorrectly at idler pins.
	Crosscut knives striking knife fasteners (22 knife spindle)	Use correct knife fasteners. See "Crosscut Knife Spindle Assembly", page 83.

MAINTENANCE

Troubleshooting

PROBLEM	CAUSE	CORRECTION
Machine Does Not Start	Guards and covers not securely attached	Make sure guards and covers are securely attached. Check for bent or twisted guards or covers that will prevent switches from lining up. See “Safety Switches”, page 22.
	Blown fuses	Check main fuses, transformer fuses and amplifier fuses.
	Amplifier malfunction	Check amplifier. See “Inspection”, page 58 or “Electrical Schematic”, pages 94 & 95.
	Overload relay tripped	Wait 5 minutes. Press “RESET” button.
	Electrical system malfunction	Inspect electrical system. See “Inspection”, page 58.
Motor Frequently Becomes Overloaded	Machine overload or jam	See “Machine Overload or Jam”, page 26.
	Power source too low	Incoming power must be at least 95% of specified voltage.
	Dull knives	Sharpen or replace as required
	Motor electrical problem	Perform electrical check on motor
	Feed rate too high	See “Feeding Product”, page 25.
Slow, Sluggish Operation	Drive belts slipping	Replace worn or frayed belts and adjust belt tension. Make sure belts are clean, dry and free of grease. Check for worn pulley grooves.
	Lack of lubrication	See “Lubrication”, page 29.
	Loss of one phase of power	Perform complete electrical check on motor and starter. See “Electrical Schematic”, pages 94 & 95.
	Motor electrical problem	Perform complete electrical check on motor and electrical assembly. See “Electrical Schematic”, pages 94 & 95.
Machine does not come to a rapid stop when the “O” (STOP) button is pushed	Motor brake in need of repair	Refer to page 97 and brake manufacturer's literature.

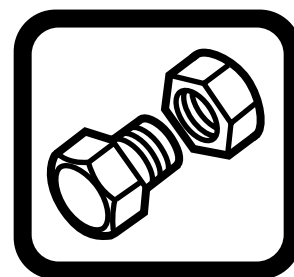

PARTS

PARTS

Maintenance Videotapes

The following instructional videotapes are available from Urschel Laboratories, Inc.

NOTE: *NTSC format is used in the United States, Canada and Mexico.*

	NTSC	FORMAT	
		PAL	SECAM
		PART NO.	
Machine Maintenance (English)	12675	12678	12679
Knife Assembly Maintenance (English)	13568	13578	13579
Knife Assembly Maintenance, 22 Knife Spindle (English)	13570	13581	13582

NOTE: *These tapes are approximately 30 minutes in length and should be used in conjunction with this manual, not as a substitute.*

ORDERING PARTS

When ordering parts be sure to include the following information:

- **Machine Model and Serial Number**
- **Quantity**
- **5 Digit Part Number**
- **Part Description**

The serial number of your machine is on the name plate located on the main support casting. Orders are accepted by mail, telephone or facsimile. Do not use illustration numbers when ordering parts.

RETURNING PARTS FOR REPAIR

1. Pack part(s) securely to avoid damage during shipping.
2. Enclose purchase order number and letter of instruction for repair work. Note any special instructions.
3. Include name and phone number of person to contact if further information is required by repair department.

Customers in U.S.A.: It is not necessary to inform Urschel Laboratories, Inc. by phone that you are returning parts for repair as long as complete instructions are included in package.

Customers Outside U.S.A.: Contact your nearest Urschel representative. If repair services are not available from your representative, you may wish to inquire by fax about shipping and related expenses to determine if repair at the Valparaiso factory is cost effective. The country code for dialing the U.S.A. is 1.

Urschel Laboratories, Inc.
2503 Calumet Avenue
Valparaiso, Indiana 46383 U.S.A.
Telephone: 219/464-4811
Fax: 219/462-3879

PARTS

Tools

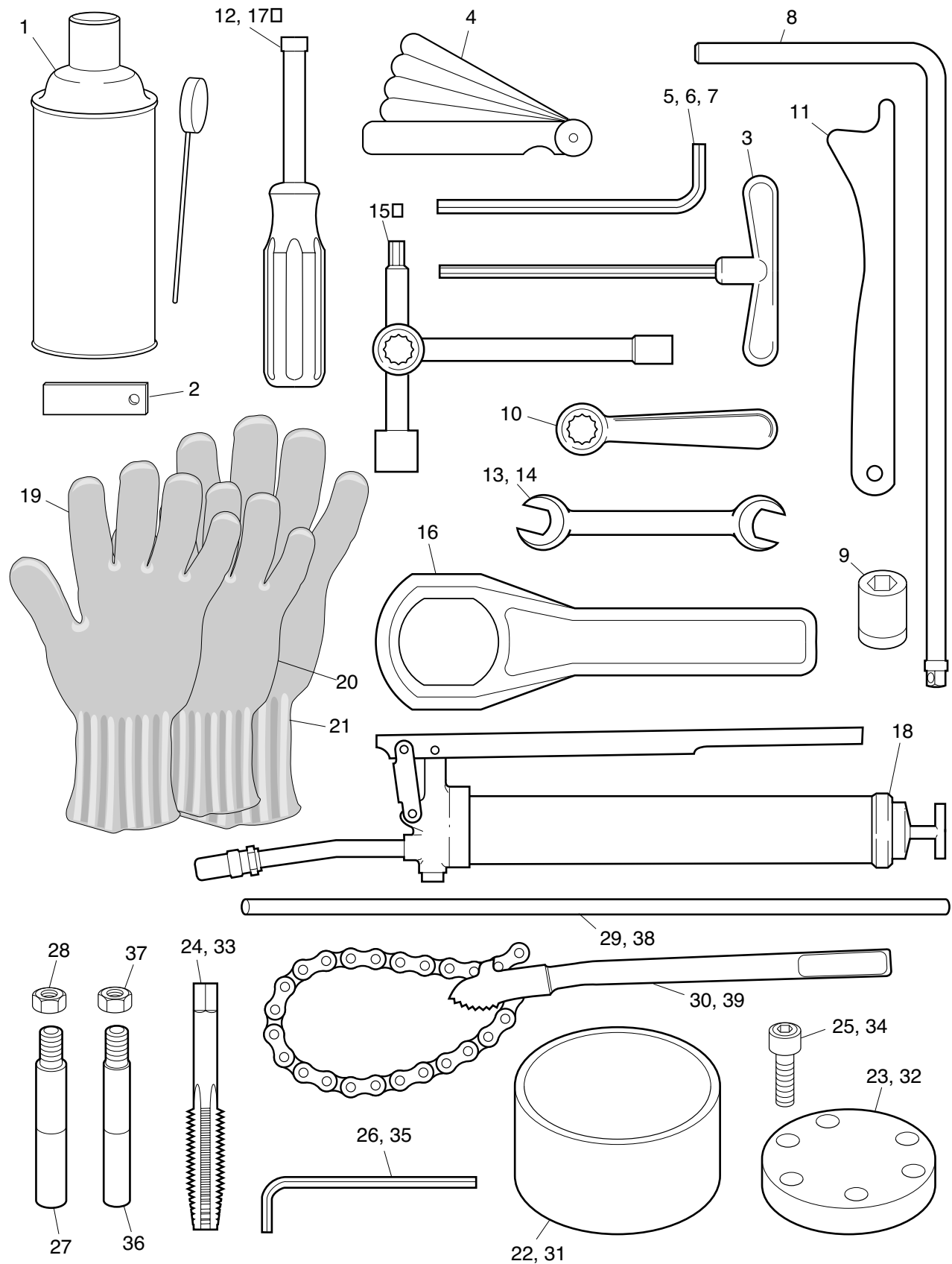

ITEM NO.	PART NO.	DESCRIPTION	QTY.
1	11001	Spray Lubricant , (cannot be shipped via air freight)	1
2	12228	Gauge , case adjustment	1
3	11050	Allen Wrench , "T" handle—5/32"	1
4	11042	Feeler Gauge	1
5	11051	Allen Wrench , 3/16"	1
6	11053	Allen Wrench , 5/16"	1
7	11054	Allen Wrench , 1/4"	1
8	62297	Wrench Handle , square drive , 3/8"	1
9	11011	Socket , 9/16"	1
10	11029	Box End Wrench	1
11	13264	Slicing Knife Remover	1
12	11002	Nut Driver , 5/16"	1
13	11038	Open End Wrench , 7/16 x 1/2"	1
14	11039	Open End Wrench , 1/2 x 9/16"	1
15	13597	"T" Handle Wrench	1
16	16389	Spindle Wrench	1
17	11046	Nut Driver , 1/4", (for use on 22 knife crosscut spindle)	1
18	11070	Grease Gun	1
19	17453	Protective Glove , medium, (fits hand sizes 7, 8 & 9)	2
—	11045	Grease Cartridge , (not shown)	2
—	11071	Tool Box , (not shown)	1

OPTIONAL TOOLS (NOT SUPPLIED WITH MACHINE)

20	17497	Protective Glove , small, (fits hand sizes 5, 6 & 7)	2
21	17498	Protective Glove , large, (fits hand sizes 9, 10 & 11)	2

TOOLS FOR BEARING BLOCK REPLACEMENT

—	13620	Tool Kit for 7, 8, 10, 12, 14 & 16 knife crosscut spindles , (includes items 22–30)	1
22	13627	Support Tube	1
23	13626	Pusher Block	1
24	13628	Tap , 7/16-14	1
25	10390	Bolt , 7/16-14 x 1-1/2"	2
26	11055	Allen Wrench , 3/8"	1
27	13624	Installation Pins	3
28	10021	Nuts , 5/16-18	3
29	13622	Installation Rods	3
30	11015	Chain Wrench	1
—	13621	Tool Kit for 22 knife crosscut spindle , (includes items 31–39)	1
31	13627	Support Tube	1
32	13626	Pusher Block	1
33	13629	Tap , 3/8-16	1
34	10114	Bolt , 3/8-16 x 1-1/2"	2
35	11053	Allen Wrench , 5/16"	1
36	13625	Installation Pins	3
37	10021	Nuts , 5/16-18	3
38	13623	Installation Rods	3
39	11015	Chain Wrench	1

TOOLS FOR KNIFE SHARPENING

—	11004	Buffing Wheel , 10" diameter, (not shown)	1
—	11005	Buffing Compound , 3 pound bar, (not shown)	1
—	11014	Knife Holding Clamp , for buffing crosscut knives, (not shown)	1

PARTS

Frame, Covers and Guards

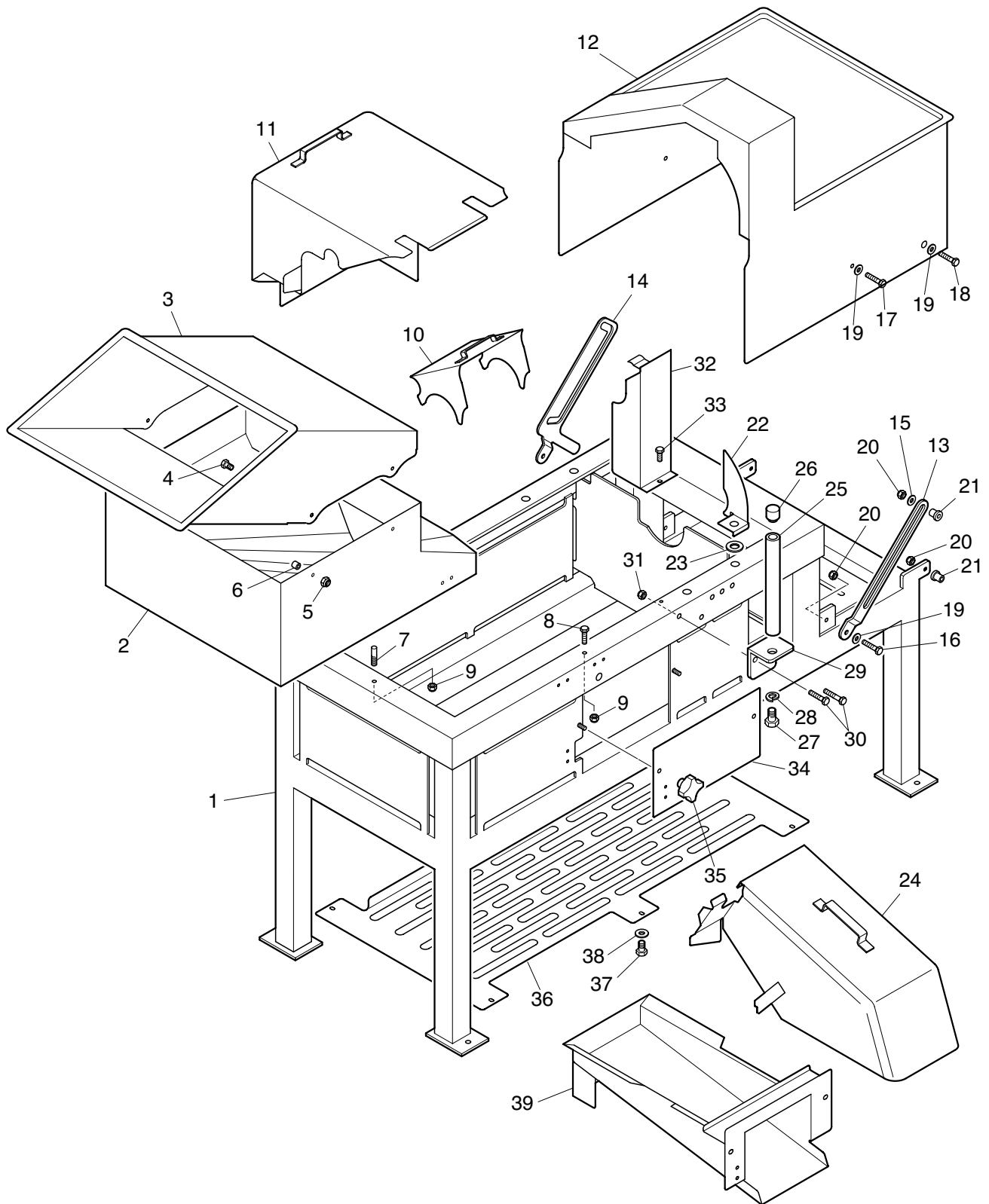

PARTS

Frame, Covers and Guards

ITEM NO.	PART NO.	DESCRIPTION	QTY.
1	13641	Frame, 30" discharge height.	1
2	12149	Feed Hopper, for 7" opening	1
3	13655	Hopper Extension.	1
4	10039	Hex Head Cap Screw, 1/4-20 x 1"	4
5	10230	Hex Nut, locking, 1/4-20	4
6	19603	Spacer, 7/16"	4
7	35037	Stud, 5/16-18 x 1-1/8"	1
8	10046	Hex Head Cap Screw, 5/16-18 x 7/8"	2
9	10306	Hex Nut, locking, 5/16-18	3
10	13440	Shield	1
11	13368	Chip Chute Enclosure	1
12	13664	Motor Cover.	1
13	13650	Support.	1
14	13651	Support, latching.	1
15	10008	Flat Washer, 5/16"	2
16	10047	Hex Head Cap Screw, 5/16-18 x 1"	2
17	10048	Hex Head Cap Screw, 5/16-18 x 1-1/4"	2
18	10049	Hex Head Cap Screw, 5/16-18 x 1-1/2"	2
19	10288	Flat Washer, 5/16"	6
20	10306	Hex Nut, locking, 5/16-18	6
21	19518	Mounting Bushing	4
22	13652	Drive Guard	1
23	15400	Washer	1
24	13277	Discharge Chute.	1
25	15033	Support Post, (includes item 26).	1
26	12688	Urethane Bumper	1
27	10083	Hex Head Cap Screw, 5/8-11 x 1"	1
28	10017	Lock Washer, 5/8"	1
29	13032	Support Post Bracket	1
30	10059	Hex Head Cap Screw, 3/8-16 x 1-1/4"	2
31	10249	Hex Nut, locking, 3/8-16	2
32	13063	Gear Guard	1
33	10251	Hex Head Cap Screw, locking, 1/4-20 x 1/2"	1
34	13654	Side Cover.	1
35	63825	Hand Knob, 5/16-18, stainless steel	2
36	13653	Bottom Grid.	1
37	10251	Hex Head Cap Screw, locking, 1/4-20 x 1/2"	6
38	10007	Flat Washer, 1/4"	6
39	13660	Juice Chute, (alternate part, replaces item 34)	1

PARTS

Slicing Unit (G-A)

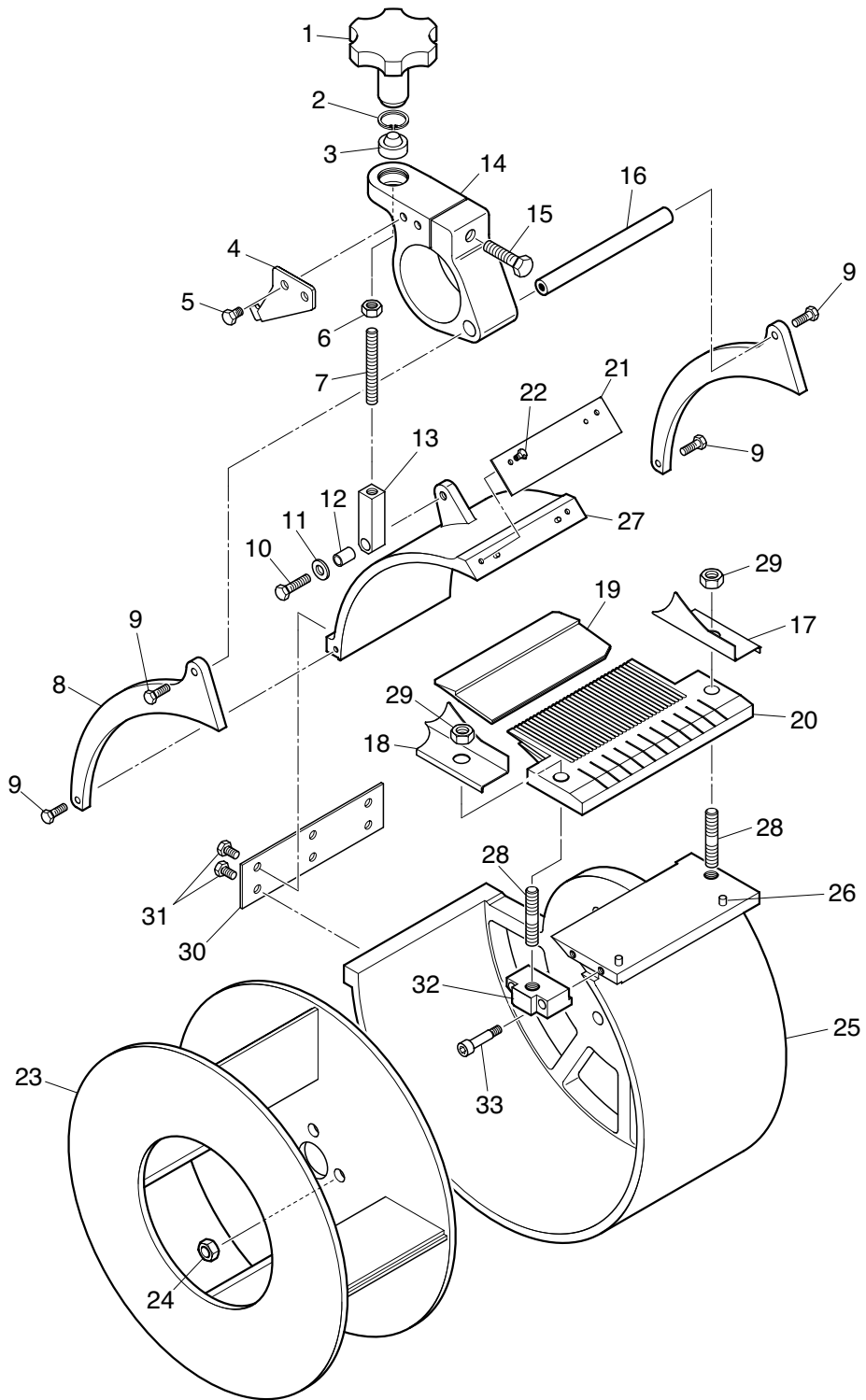

PARTS

Slicing Unit (G-A)

ITEM NO.	PART NO.	DESCRIPTION	QTY.
—	13247	Chip Guard & Slice Adjustment Assembly, (includes items 1–16)	1
1	13218	Adjustment Knob, for slice gate	1
2	13237	Retaining Ring	1
3	17021	Spherical Bearing	1
4	13226	Indicating Arm	1
5	10224	Hex Head Cap Screw, 10-24 x 1/4"	2
6	10022	Hex Nut, 3/8-16	1
7	13221	Stud, 3/8-16 x 2-3/8"	1
8	13216	Chip Guard	2
9	10308	Hex Head Cap Screw, locking, 1/4-20 x 5/8"	4
10	10059	Hex Head Cap Screw, 3/8-16 x 1-1/4"	1
11	10009	Flat Washer, 3/8"	1
12	13238	Hinge Bushing, slice adjustment.	1
13	13220	Adjustment Nut, slice gate.	1
14	13215	Clamp, slice gate, (includes item 15).	1
15	10060	Hex Head Cap Screw, 3/8-16 x 1-1/2"	1
16	13217	Support, chip guard	1
17	13545	Slice Guide, rear	1
18	13544	Slice Guide, front	1
19	13104	† Slicing Knife	1
20	§	Slicing Knife Holder	1
21	(see chart)	Gate Extension Strip	1
22	(see chart)	Hex Head Cap Screw, locking	2
23	12440	‡ Impeller, stainless steel	1
24	10249	Hex Nut, locking, 3/8-16	3
—	13249	Case Assembly, stainless steel, (includes items 25–33)	1
25	12018	Case, stainless steel, (includes item 26)	1
26	37040	Dowel Pin, 1/4" dia. x 5/8"	2
27	12012	Case Gate, stainless steel	1
28	48125	Stud, 1/2-13 x 1-3/4"	2
29	10026	Hex Nut, 1/2-13	2
30	12174	Hinge Plate	1
31	10307	Hex Head Cap Screw, locking, 5/16-18 x 1/2"	6
32	12074	Clamp Block.	1
33	12175	Shoulder Bolt	2

† For optional slicing knives, see page 100.

§ See charts, page 85.

‡ For optional impellers, see page 100.

Slice Thickness	Item 21 Gate Ext. Strip	Item 22 Screw
1/16-5/32" (1.6-4.0 mm)	12186	10250
3/16-11/32" (4.8-8.7 mm)	12188	10250
3/8-15/32" (9.5-11.9 mm)	12189	10250
1/2-23/32" (12.7-18.3 mm)	12191	10250
3/4" (19.1 mm)	12193	10298

PARTS

Slicing Unit (GK-A)

See the addendum
for updated information

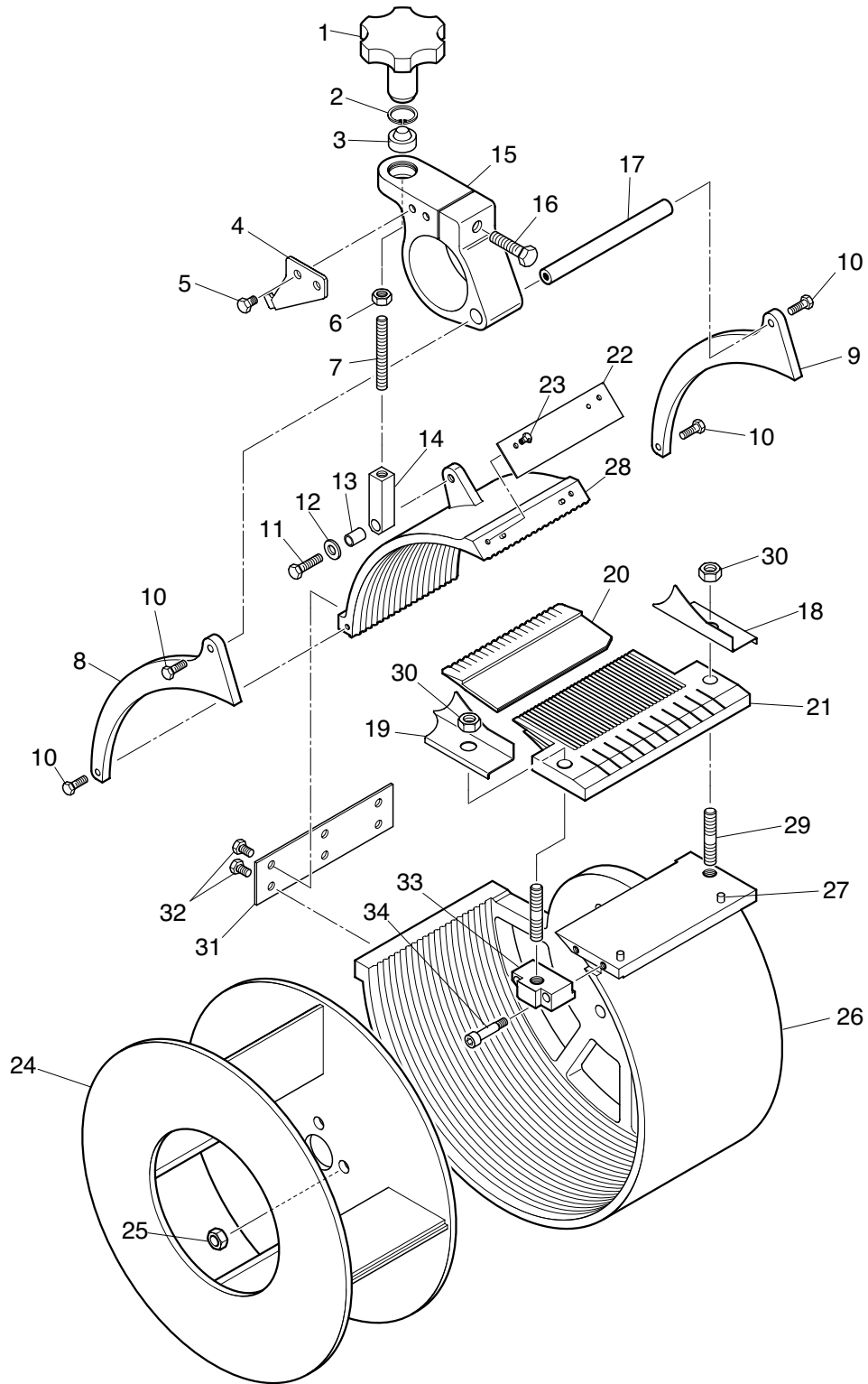

PARTS

Slicing Unit (GK-A)

ITEM NO.	PART NO.	DESCRIPTION	QTY.
—	14041	Chip Guard & Slice Adjustment Assembly, (includes items 1–17)	1
1	13218	Adjustment Knob	1
2	13237	Retaining Ring	1
3	17021	Spherical Bearing	1
4	13226	Indicator Arm	1
5	10224	Hex Head Cap Screw, 10-24 x 1/4"	2
6	10022	Hex Nut, 3/8-16	1
7	13221	Stud, 3/8-16 x 2-3/8"	1
8	14039	Chip Guard, front	1
9	14040	Chip Guard, back	1
10	10308	Hex Head Cap Screw, locking, 1/4-20 x 5/8"	4
11	10059	Hex Head Cap Screw, 3/8-16 x 1-1/4"	1
12	10009	Flat Washer, 3/8"	1
13	13238	Hinge Bushing, slice adjustment	1
14	13220	Adjustment Nut	1
15	13215	Clamp, slice gate, (includes item 16)	1
16	10060	Hex Head Cap Screw, 3/8-16 x 1-1/2"	1
17	13217	Support, chip guard	1
18	13545	Slice Guide, rear	1
19	13544	Slice Guide, front	1
20	14023	† Slicing Knife, crinkle cut	1
—	13104	† Slicing Knife, straight cut	1
21	§	Slicing Knife Holder	1
22	(see chart)	Gate Extension Strip	1
23	(see chart)	Hex Head Cap Screw, locking	2
24	14042	‡ Impeller	1
25	10249	Hex Nut, locking, 3/8-16	3
—	14017	Case Assembly, (includes items 26–34)	1
26	14018	Case, (includes item 27)	1
27	37040	Dowel Pin, 1/4" dia. x 5/8"	2
28	14019	Case Gate	1
29	48125	Stud, 1/2-13 x 1-3/4"	2
30	10026	Hex Nut, 1/2-13	2
31	12174	Hinge Plate	1
32	10307	Hex Head Cap Screw, locking, 5/16-18 x 1/2"	6
33	12074	Clamp Block	1
34	12175	Shoulder Bolt	2

- † For optional slicing knives, see page 100.
 § See charts, page 85.
 ‡ For optional impellers, see page 100.

Slice Thickness	Item 22 Gate Ext. Strip	Item 23 Screw
<i>Crinkle Cut</i>		
1/16-5/32" (1.6-4.0 mm)	12186	10250
3/16-11/32" (4.8-8.7 mm)	12188	10250
3/8-15/32" (9.5-11.9 mm)	12189	10250
1/2-23/32" (12.7-18.3 mm)	12191	10250
3/4" (19.1 mm)	12193	10298
<i>Straight Cut</i>		
1/16-11/32" (1.6-8.7 mm)	12187	10250
3/8-15/32" (9.5-11.9 mm)	12190	10298
1/2-3/4" (12.7-19.1 mm)	12192	10298

PARTS

Dicing Unit

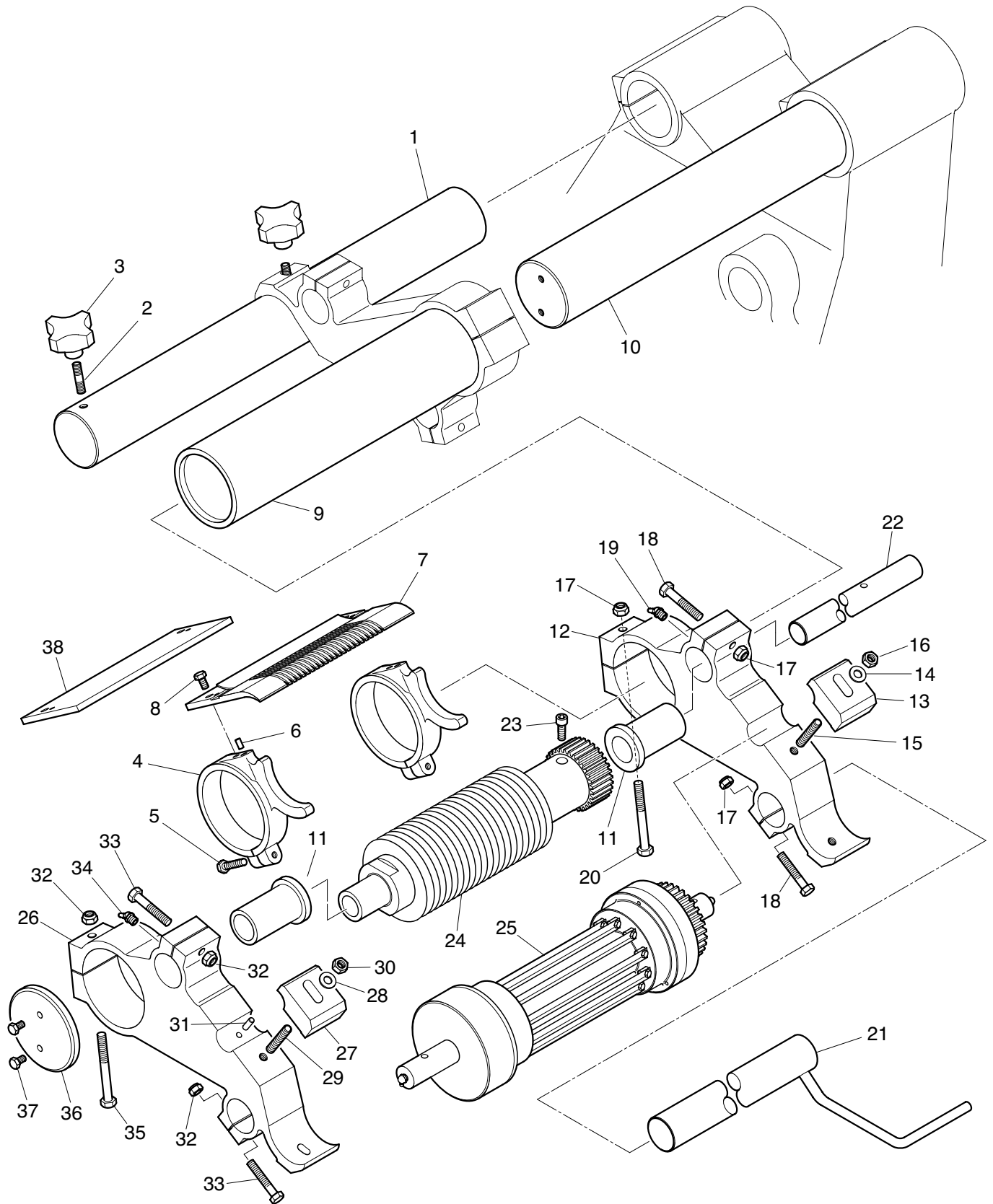

PARTS

Dicing Unit

ITEM NO.	PART NO.	DESCRIPTION	QTY.
1	12208	Support Bar, clamp end	1
2	18101	Stud, 5/16-18 x 1-1/4"	2
3	63825	Hand Knob, 5/16-18, stainless steel	2
4	13340	Clamp Ring and Cradle, (includes items 5 & 6)	2
5	10059	Hex Head Cap Screw, 3/8-16 x 1-1/4"	1
6	37040	Dowel, 1/4 x 5/8"	1
7	*	Stripper Plate	1
8	10044	Hex Head Cap Screw, 5/16-18 x 5/8"	2
9	12201	Hinge Tube, with bearings	1
10	12204	Support Bar, hinge end	1
11	16114	Bearing, with thrust washer, 1 x 1-1/2 x 2-9/16"	2
12	13005	Side Frame Assembly, right, (includes items 13–20)	1
13	13219	Cap, side frame	1
14	10270	Flat Washer, 3/8"	1
15	62195	Stud, 3/8-16 x 1-15/16"	1
16	10022	Hex Nut, 3/8-16	1
17	10306	Hex Nut, locking, 5/16-18	3
18	10050	Hex Head Cap Screw, 5/16-18 x 1-3/4"	2
19	11418	Grease Fitting, 1/8", 30°	1
20	10054	Hex Head Cap Screw, 5/16-18 x 2-3/4"	1
21	13260	Tie Bar, with handle	1
22	12197	Shaft, circular knife spindle	1
23	16050	Socket Head Cap Screw, 3/8-16 x 3/4"	1
24	*	Circular Knife Spindle Assembly	1
25	‡	Crosscut Knife Spindle Assembly	1
26	13003	Side Frame Assembly, left, (includes items 27–35)	1
27	13219	Cap, side frame	1
28	10270	Flat Washer, 3/8"	1
29	62195	Stud, 3/8-16 x 1-15/16"	1
30	10022	Hex Nut, 3/8-16	1
31	37040	Dowel, 1/4 x 5/8"	1
32	10306	Hex Nut, locking, 5/16-18	3
33	10050	Hex Head Cap Screw, 5/16-18 x 1-3/4"	2
34	11418	Grease Fitting, 1/8", 30°	1
35	10054	Hex Head Cap Screw, 5/16-18 x 2-3/4"	1
36	12213	Retaining Cap	1
37	10037	Hex Head Cap Screw, 1/4-20 x 1/2"	2
38	12081	Support, discharge chute, (replaces item 7 stripper plate when machine is used for strip cutting or slicing only)	1

* See page 85.
‡ See pages 81 & 83.

PARTS

Drive Train

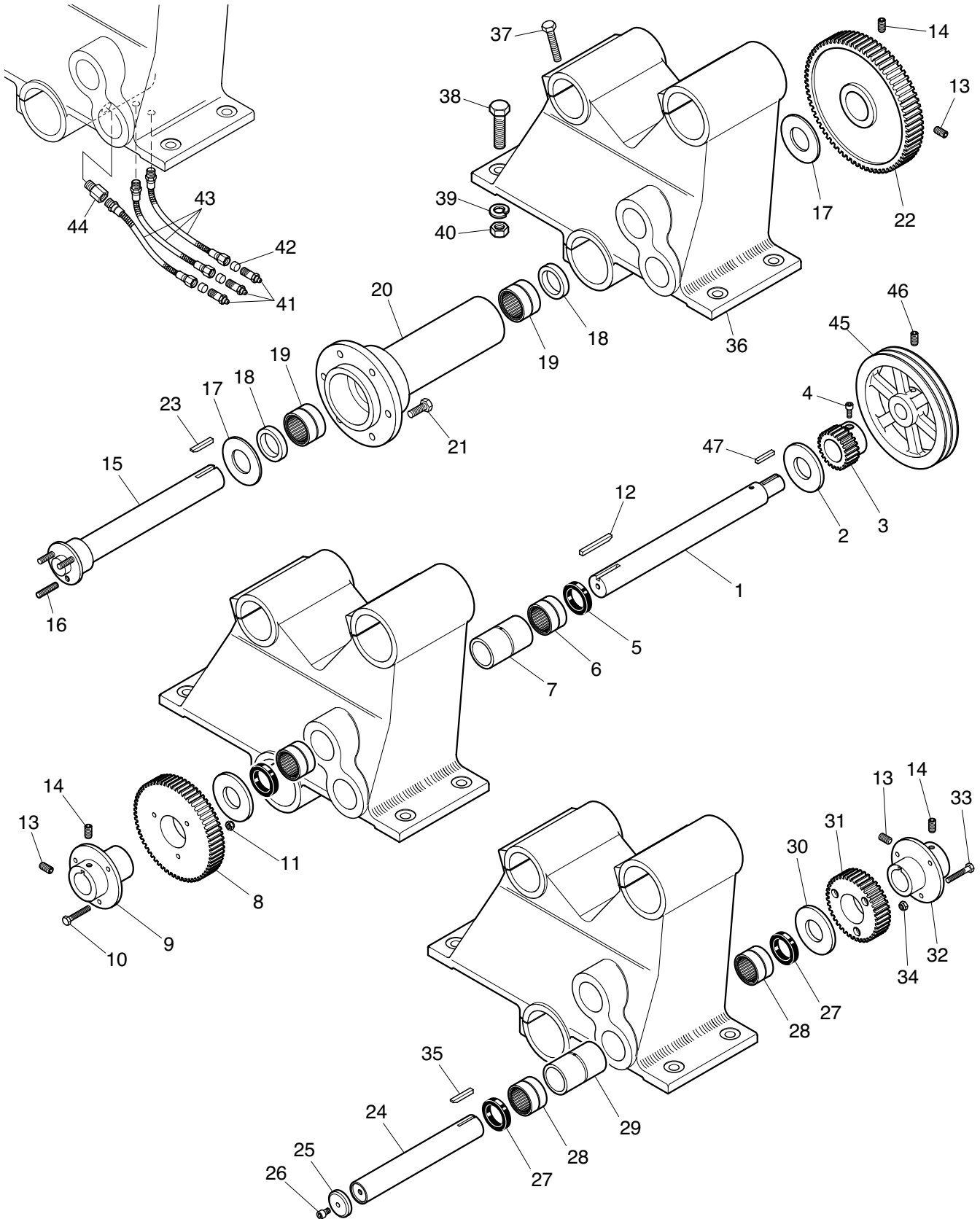

PARTS

Drive Train

ITEM NO.	PART NO.	DESCRIPTION	QTY.
1	12199	Shaft, main drive	1
2	12216	Thrust Washer	2
3	12178	Gear, 22 teeth, stainless steel	1
4	16050	Socket Head Cap Screw, 3/8-16 x 3/4"	1
5	12214	Oil Seal	2
6	12226	Roller Bearing, jack & drive shaft	2
7	12073	Bearing Spacer Tube	1
—	12179	Gear Assembly, 62 teeth, (includes items 8–11)	1
8	12180	Gear, 62 teeth, nylon	1
9	12181	Hub, (includes 1 each of items 13 & 14)	1
10	10040	Hex Head Cap Screw, 1/4-20 x 1-1/4"	3
11	10230	Hex Nut, locking, 1/4-20	3
12	18066	Key, 1/4 square x 2"	1
13	10140	Socket Set Screw, locking, 5/16-18 x 3/8"	3
14	10139	Socket Set Screw, locking, 5/16-18 x 5/16"	3
15	12436	Shaft, impeller, (includes item 16)	1
16	62193	Stud, 3/8-16 x 1-7/16"	3
17	12217	Thrust Washer	2
18	12215	Oil Seal	2
19	12218	Roller Bearing, impeller shaft	2
20	12009	Bearing Housing	1
21	10072	Hex Head Cap Screw, 1/2-13 x 1"	6
22	12177	Gear, 83 teeth, bronze, (includes one each of items 13 & 14)	1
23	12229	Key, 1/4 x 1-3/4"	1
24	12200	Jack Shaft	1
25	12077	Retaining Washer	1
26	10098	Socket Head Cap Screw, 5/16-18 x 1/2"	1
27	12214	Oil Seal	2
28	12226	Roller Bearing, jack & drive shaft	2
29	12073	Bearing Spacer Tube	1
30	12216	Thrust Washer	1
—	12182	Gear Assembly, 40 teeth, (includes items 31–34)	1
31	12183	Gear, 40 teeth, nylon	1
32	12184	Hub, (includes one each of items 13 & 14)	1
33	10040	Hex Head Cap Screw, 1/4-20 x 1-1/4"	3
34	10230	Hex Nut, locking, 1/4-20	3
35	12229	Key, 1/4 x 1-3/4"	1
36	13002	Main Support Casting Assembly, (includes item 37)	1
37	10062	Hex Head Cap Screw, 3/8-16 x 2"	6
38	10084	Hex Head Cap Screw, 5/8-11 x 2"	4
39	10017	Lock Washer, 5/8"	4
40	10028	Hex Nut, 5/8-11	4
41	11435	Grease Fitting, 1/8", straight	3
42	12131	Spacer	3
43	12129	Grease Hose	3
44	11493	Pipe Adapter, 1/8"	1
45	12219	Pulley, 7.25 O.D., 1.000 I.D., 2 groove w/set screw, (includes item 46)	1
46	10504	Socket Set Screw, 5/16-18 x 3/8"	1
47	12229	Key, 1/4 x 1-3/4"	1

PARTS

Crosscut Knife Spindle Assembly (7, 8, 10, 12, 14, & 16 Knives)

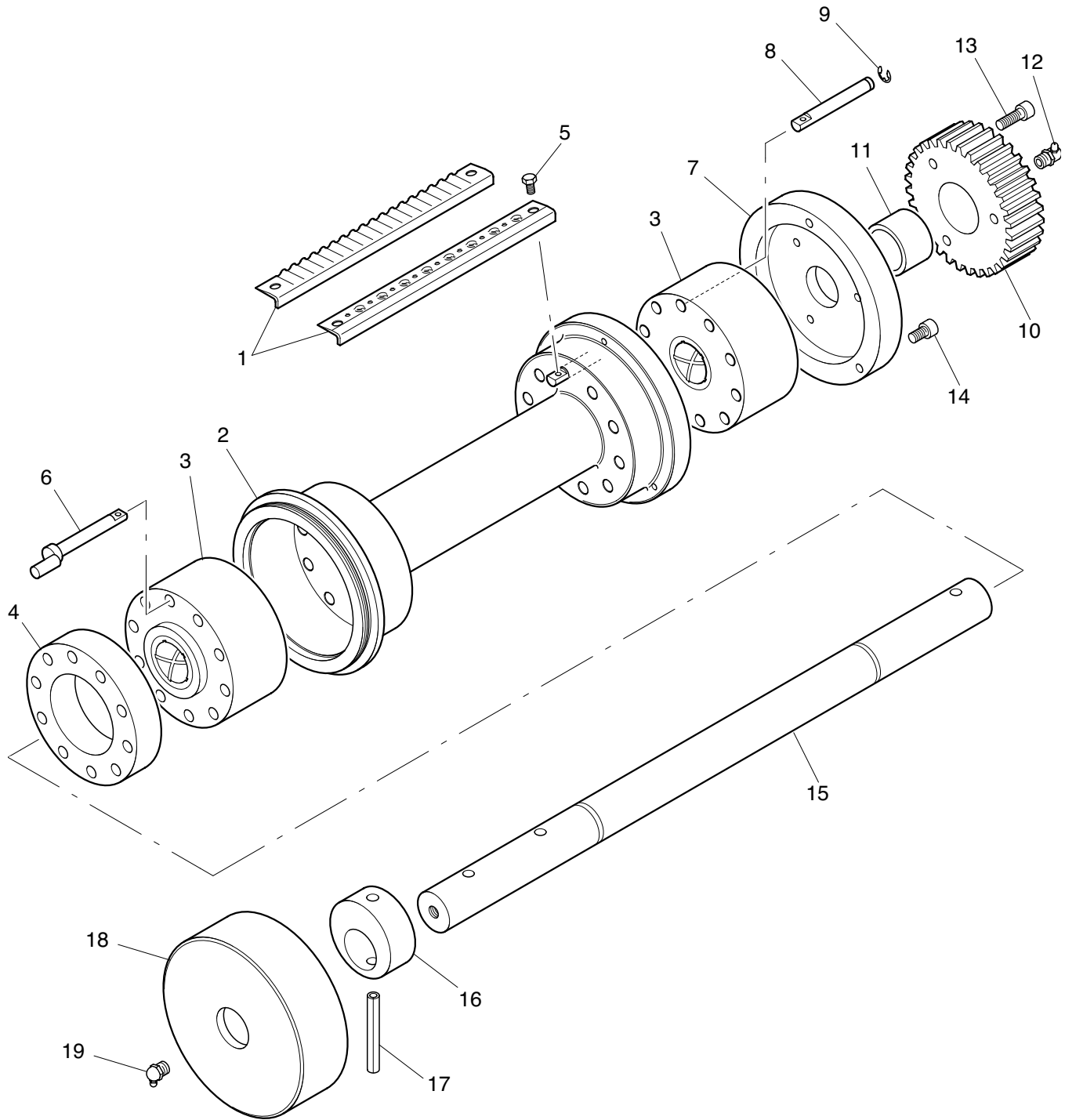

PARTS

Crosscut Knife Spindle Assembly (7, 8, 10, 12, 14, & 16 Knives)

ITEM NO.	PART NO.	DESCRIPTION	QTY.
—	(see chart)	Spindle Assembly, crosscut, stainless steel, (includes items 1–19)	1
—	(see chart)	Spindle Assembly, crosscut, crinkle, (includes items 1–19)	1
1	(see chart)	Knife, straight cut	*
	(see chart)	Knife, crinkle cut	*
2	(see chart)	Spindle, (includes item 3)	1
3	(see chart)	Bearing Block	2
4	(see chart)	Crank Bearing Block	1
5	12110	Hex Head Screw	†
6	12102	Crank Pin	‡
7	13293	Drive Cap	1
8	12103	Idler Pin, (includes item 9)	‡
9	12285	Retaining Ring	1
10	13070	Gear, 32 teeth, stainless steel, (includes item 11)	1
11	13061	Bearing, for 13070 gear	1
12	11402	Grease Fitting, 1/8", 65°	1
13	10094	Socket Head Cap Screw, 1/4-20 x 1"	3
14	10090	Socket Head Cap Screw, 1/4-20 x 5/8"	3
15	13074	Shaft, crosscut spindle	1
16	13046	Eccentric, with roll pin, (includes item 17)	1
17	12105	Roll Pin, 1/4 x 1-1/2"	1
18	13292	End Cap	1
19	11403	Grease Fitting, 1/8", 90°	1

† Two (2) hex head screws required for each knife.

‡ One (1) crank pin and one (1) idler pin required for each knife.

Size of Cut inch mm	Assembly Number		Item 1 Knife			Item 2 Spindle with Bearing Blocks	Item 3 Bearing Block Only	Item 4 Crank Bearing Block
	Straight	Crinkle	Straight	Crinkle	Qty.			
3/8 (9.5)	13322	14051	12283	12284	16	13321	13058	13052
7/16 (11.1)	13330	14052	12283	12284	14	13329	13057	13051
1/2 (12.7)	13299	14053	13144	14027	12	13298	13054	13048
5/8 (15.9)	13331	14055	13144	14027	10	13301	13155	13154
3/4 (19.1)	13612	—	13144	—	8	13613	13615	13616
7/8 (22.2)	13334	14054	13144	14027	7	13333	13055	13049

PARTS

Crosscut Knife Spindle Assembly (22 Knives)

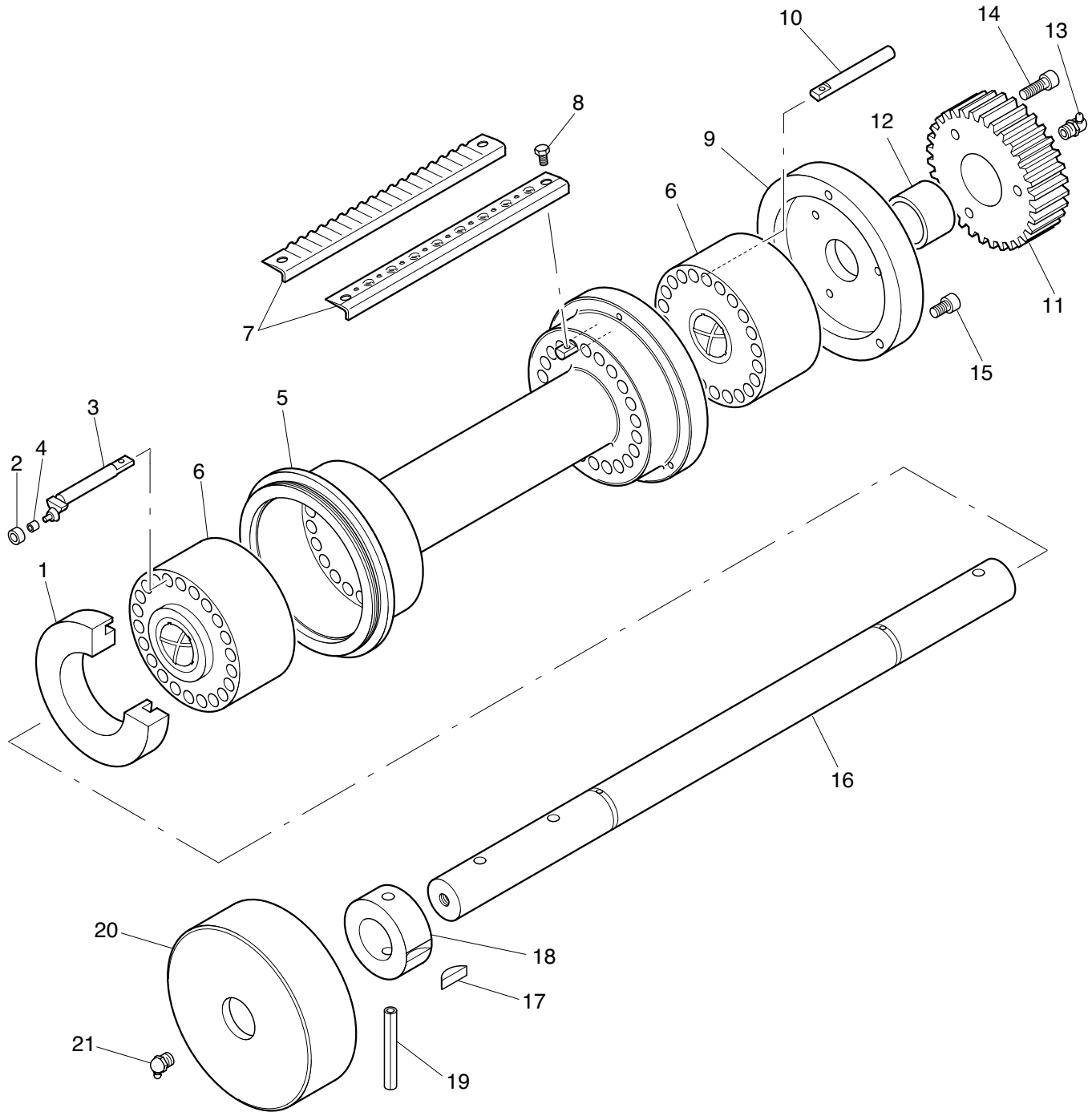

PARTS

Crosscut Knife Spindle Assembly (22 Knives)

ITEM NO.	PART NO.	DESCRIPTION	QTY.
—	13344	Spindle Assembly , crosscut, 22 knife, stainless steel, (9/32" cut), (includes items 1–21)	1
—	14056	Spindle Assembly , crosscut, 22 knife, crinkle, (9/32" cut), (includes items 1–21)	1
1	13192	Cam , 9/32.	1
2	13196	Roller , crank pin.	22
3	13194	Crank Pin , 9/32, (includes item 4)	22
4	13201	Sleeve , crank pin, 9/32	1
5	13343	Spindle , crosscut with bearing blocks, 9/32, (includes item 6).	1
6	13191	Bearing Block , 9/32.	2
7	12283	Knife , crosscut.	22
	12284	Knife , crosscut, corrugated.	22
8	13543	Hexagon Head Screw	44
9	13293	Drive Cap	1
10	13198	Idler Pin , 9/32, crosscut spindle.	22
11	13070	Gear , 32 teeth, stainless steel, (includes item 12).	1
12	13061	Bearing , for 13070 gear	1
13	11402	Grease Fitting , 1/8", 65°	1
14	10094	Socket Head Cap Screw , 1/4-20 x 1"	3
15	10090	Socket Head Cap Screw , 1/4-20 x 5/8".	3
16	13199	Shaft , crosscut spindle, 9/32	1
17	27029	Woodruff Key	1
18	13193	Cam Hub , with roll pin, (includes item 19)	1
19	12105	Roll Pin , 1/4 x 1-1/2"	1
20	13292	End Cap	1
21	11403	Grease Fitting , 1/8", 90°	1

PARTS

Circular Knife Spindle Assembly

ITEM NO.	PART NO.	DESCRIPTION	QTY.
—	*	Circular Knife Spindle Assembly, stainless steel, (includes items 1–9)	1
1	13362	Spindle, circular knife, stainless steel, (includes items 2 & 3)	1
2	15396	Thrust Sleeve	2
3	45040	Groove Pin	2
4	16390	Nut	1
5	12281	Knife, circular, serrated	*
6	*	Spacer	*
7	16060	Feed Disc, (if required)	*
8	12176	Gear, 28 teeth, stainless steel	1
9	10094	Socket Head Cap Screw, 1/4-20 x 1"	3
10	*	Slicing Knife Holder	1
11	*	Stripper Plate	1

* See chart, page 85.

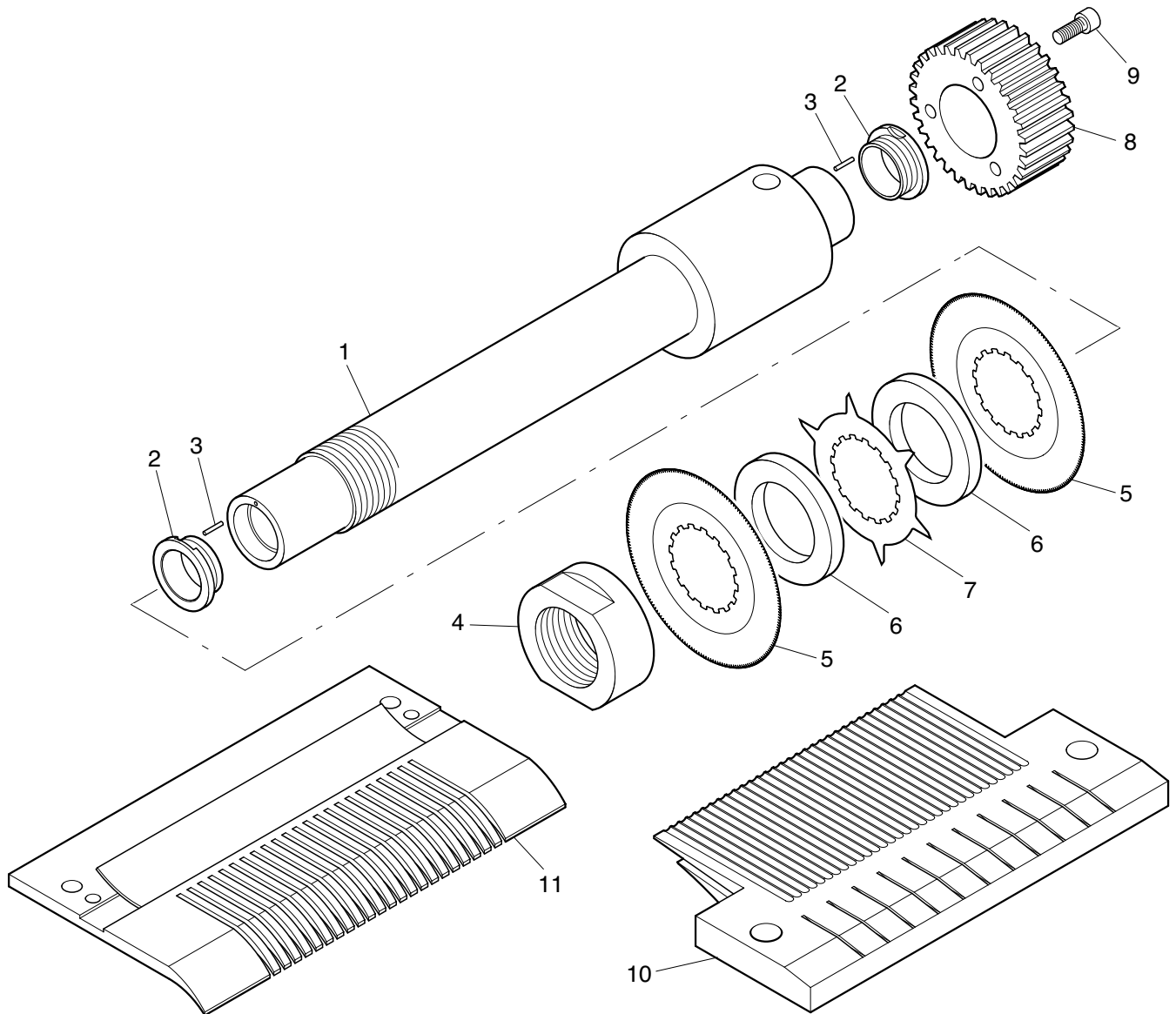

Circular Knife Spindle Assembly

CIRCULAR KNIFE SPINDLE ASSEMBLY						Item 10 SLICING KNIFE HOLDER		Item 11 STRIPPER PLATE	
Size of Cut inch mm	Assembly Number	Item 5 Knife Qty.	Item 6 Spacer No. & Qty.		Item 7 Feed Disc Qty.	No. & Slot Spacing		No. & Slot Spacing	
†† 3/32 (2.4)	13640	**65	13634	64	—	13632	3/32"	13633	3/32"
1/8 (3.2)	13676	49	16120	48	—	13016	1/8"	§ 13316	1/8"
5/32 (4.0)	13562	39	37066	39	—	13017	5/32"	§ 13586	5/32"
3/16 (4.8)	13410	33	16182	32	—	13018	3/16"	13024	3/16"
1/4 (6.4)	13411	25	16105	24	—	13016	1/8"	13025	1/4"
5/16 (7.9)	13412	20	16108	19	—	13017	5/32"	13026	5/16"
3/8 (9.5)	13413	17	16106	16	—	13016	1/8"	13027	3/8"
7/16 (11.1)	13414	14	37067	14	—	13148	7/16"	13028	7/16"
1/2 (12.7)	13415	13	16107	12	—	13016 13022	1/8" 1/2"	13029	1/2"
9/16 (14.3)	13428	12	16104 *16106	10 1	— —	13018	3/16"	13137	9/16"
.600 (15.2)	13416	11	16241	10	—	13180	.600"	13021	.600"
5/8 (15.9)	13429	11	16121 *16106	9 1	— —	13016	1/8"	13030	5/8"
3/4 (19.1)	13417	9	16109	8	—	13016	1/8"	13027	3/8"
† 3/4 (19.1)	13430	9	16106	16	8	13016	1/8"	13027	3/8"
7/8 (22.2)	13418	8	16118 *16109	6 1	— —	13016	1/8"	13023	7/8"
1 (25.4)	13419	7	16110	6	—	13016	1/8"	13029	1/2"
† 1 (25.4)	13431	7	16107	12	6	13016	1/8"	13029	1/2"
1-1/4 (31.8)	13098	6	16111 *16110	4 1	— —	13016	1/8"	13025	1/4"
1-1/2 (38.1)	13420	5	16112	4	—	13016	1/8"	13029	1/2"
† 1-1/2 (38.1)	13432	5	16109	8	4	13016	1/8"	13029	1/2"
2 (50.8)	13421	4	16027	3	—	13016	1/8"	13029	1/2"
3 (76.2)	13422	3	16028	2	—	13016	1/8"	13029	1/2"

†† Use 2-10043 Hex Head Cap Screws (5/16-18 x 1/2") in place of 2-10044 Hex Head Cap Screws (5/16-18 x 5/8") for attaching stripper plate (see page 77).

** Use knife 13638 (special thin knife).

† With feed disc.

* Last spacer to be placed on spindle.

§ Nickel plated manganese aluminum bronze.

PARTS

Electrical Assembly (NEMA)

See the addendum
for updated information

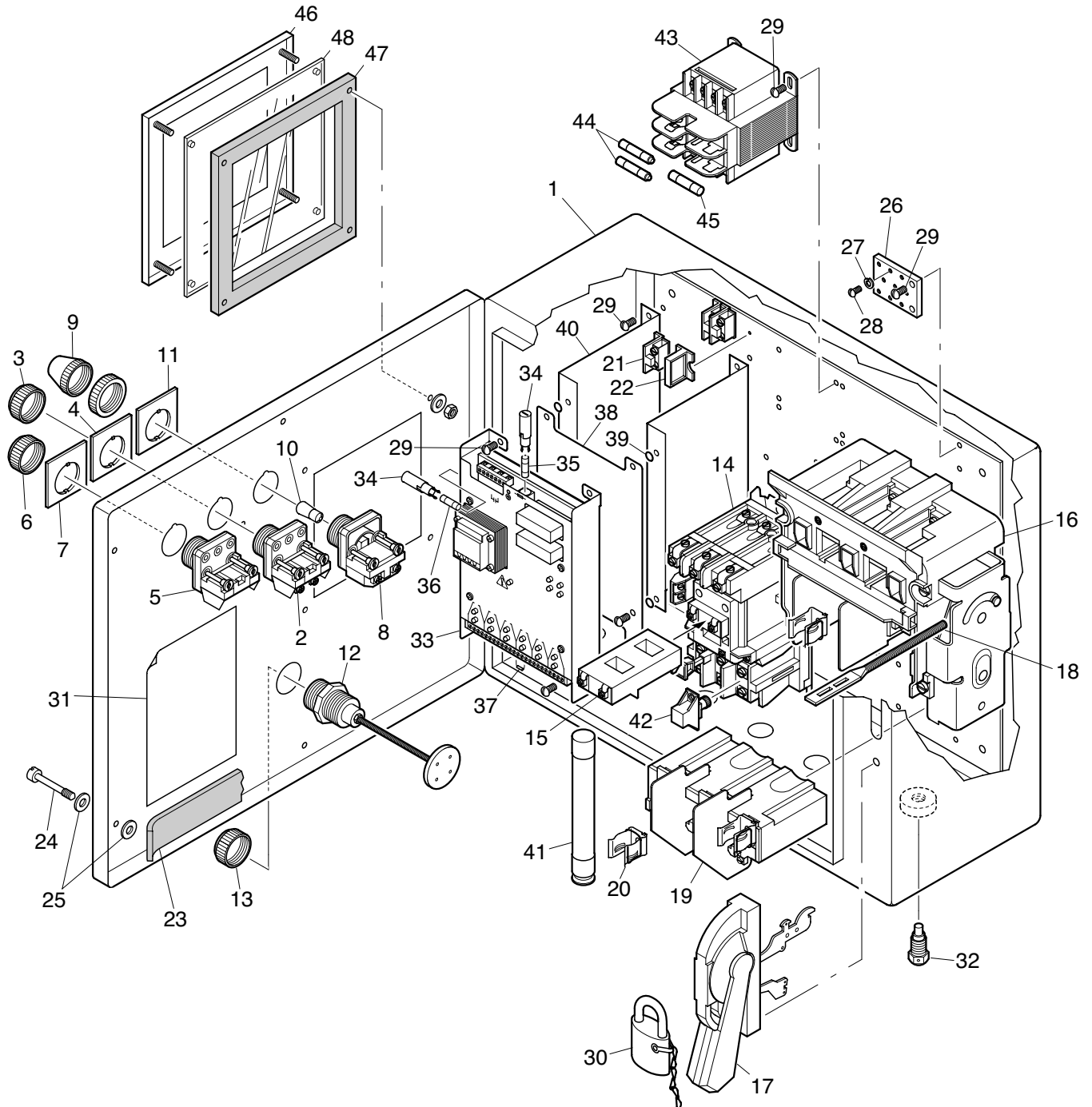

ITEM NO.	PART NO.	DESCRIPTION	QTY.
—	13700	Electrical Assembly, (includes items 1–67)	1
1	13554	Combination Starter, size "1", (includes items 2–25)	1
2	13449	Push Button, start, (includes item 3)	1
3	60218	Rubber Boot, start	1
4	12605	Legend Plate, start	1
5	13450	Push Button, stop, (includes item 6)	1
6	60219	Rubber Boot, stop	1
7	12606	Legend Plate, stop	1
8	12597	Pilot Light, (includes items 9–10)	1
9	12598	Lens, pilot light	1
10	12599	Bulb, pilot light	1
11	12600	Plate, pilot light	1
12	12603	Reset Button, (includes item 13)	1
13	12604	Rubber Boot, reset	1
14	16676	Starter, size "1"	1
15	13548	Operating Coil	1
16	13604	Disconnect	1
17	63383	Operating Handle	1
18	63384	Connecting Rod	1
19	13605	Fuse Trailer Block	1
20	13381	Fuse Clip Kit, (set of 3)	1
21	11606	Terminal Block	3
22	11607	End Section, terminal block	2
23	*	Door Gasket	72"
24	13596	Fastener for Enclosure	4
25	13602	Nylon Washer	8
26	13518	Earthing Bar	1
27	10012	Lock Washer, 3/16"	4
28	10276	Round Head Machine Screw, 10-24 x 5/16"	10
29	10625	Round Head Machine Screw, w/washer, 10-32 x 1/2"	14
30	13408	Padlock, with chain	1
31	11801	Wiring Diagram	1
32	11593	Breather/Drain, 1/4"	1
33	63737	**Amplifier, (includes items 34–37)	1
34	13673	Adapter	2
35	13671	Fuse, .630 amp.	1
36	13672	Fuse, .125 amp.	1
37	63755	Resistor, 22K	2
38	63747	Adapter Plate	1
39	12633	Rubber Washer	4
40	13561	Amplifier Bracket	2
41	*	Fuse	3
42	*	Heater Element	3
43	*	Transformer, (includes items 44–45)	1
44	12691	Fuse, .6 amp.	2
45	13426	Fuse, .6 amp.	1
46	13599	Window Replacement Kit, (includes items 47–48)	1
47	—	Window Gasket	1
48	—	Window	1

** A retrofit assembly (part no. 63756) is required to adapt 63737 amplifier to machines currently using 63068 amplifier. Consult factory for further information.

* Consult factory

Continued on page 89.

PARTS

Electrical Assembly (NEMA)

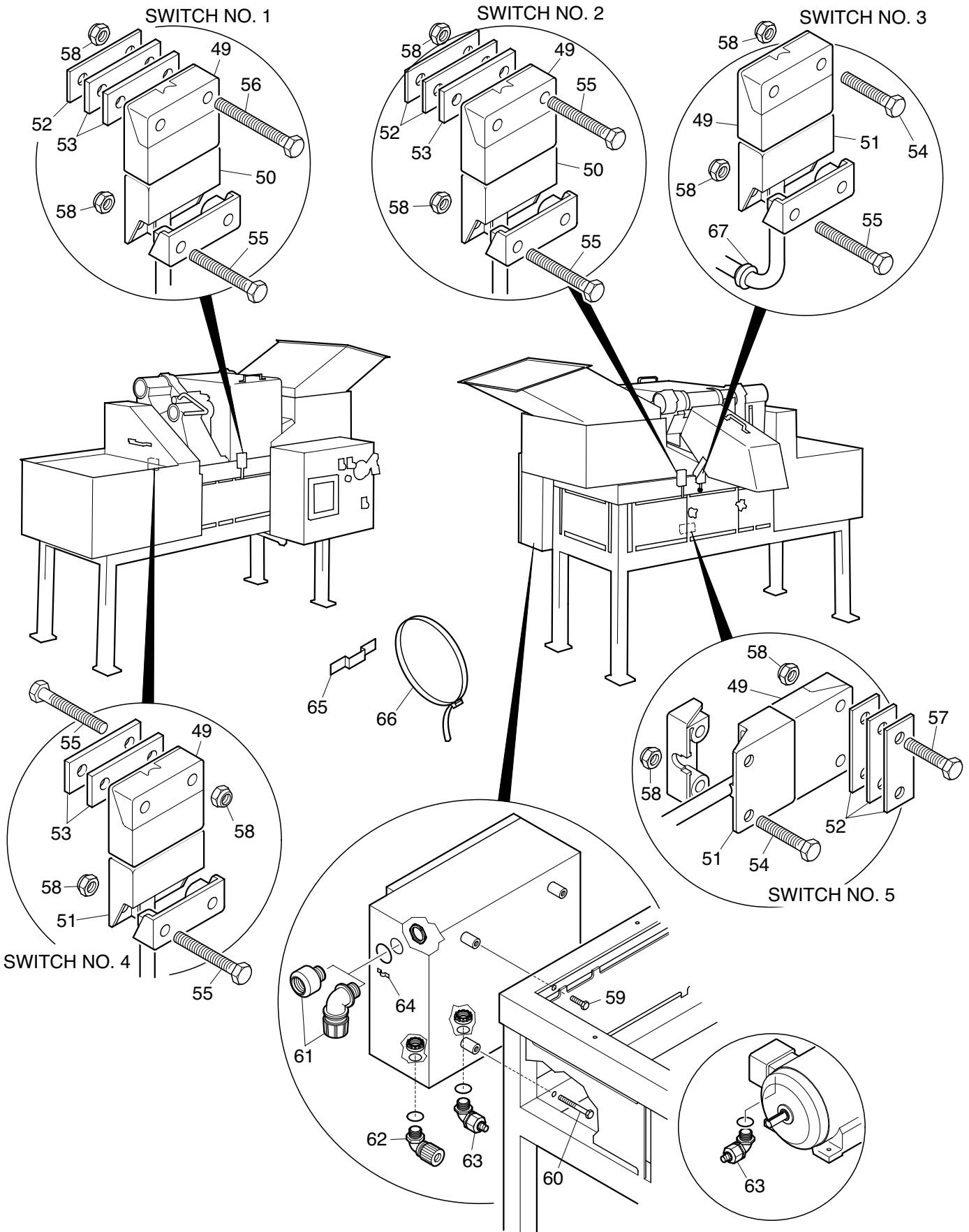

PARTS

Electrical Assembly (NEMA)

Continued from page 87.

ITEM NO.	PART NO.	DESCRIPTION	QTY.
49	63741	Actuator	5
50	63738	Sensor, 6' lead	2
51	63739	Sensor, 12' lead.	3
52	63084	Spacer, 1/32"	6
53	63227	Spacer, 3/16"	5
54	10233	Hex Head Cap Screw, 10-24 x 1"	4
55	10348	Hex Head Cap Screw, 10-24 x 1-1/4"	12
56	10349	Hex Head Cap Screw, 10-24 x 1/2"	2
57	10351	Hex Head Cap Screw, 10-24 x 7/8"	2
58	10231	Hex Nut, locking, 10-24	20
59	10044	Hex Head Cap Screw, 5/16-18 x 5/8"	2
60	10053	Hex Head Cap Screw, 5/16-18 x 2-1/2"	2
61	11582	Conduit Hub	1
	11626	Cord Connector, 90°	1
62	11548	Cord Connector, 7/32", 90°	5
63	11614	Conduit Connector, 1/2", 90°	2
64	13424	Clip, chain	1
65	13465	Clip, cable tie	23
66	11513	Cable Tie	26
67	45426	Rubber Grommet	1

PARTS

Electrical Assembly (IEC)

See the addendum
for updated information

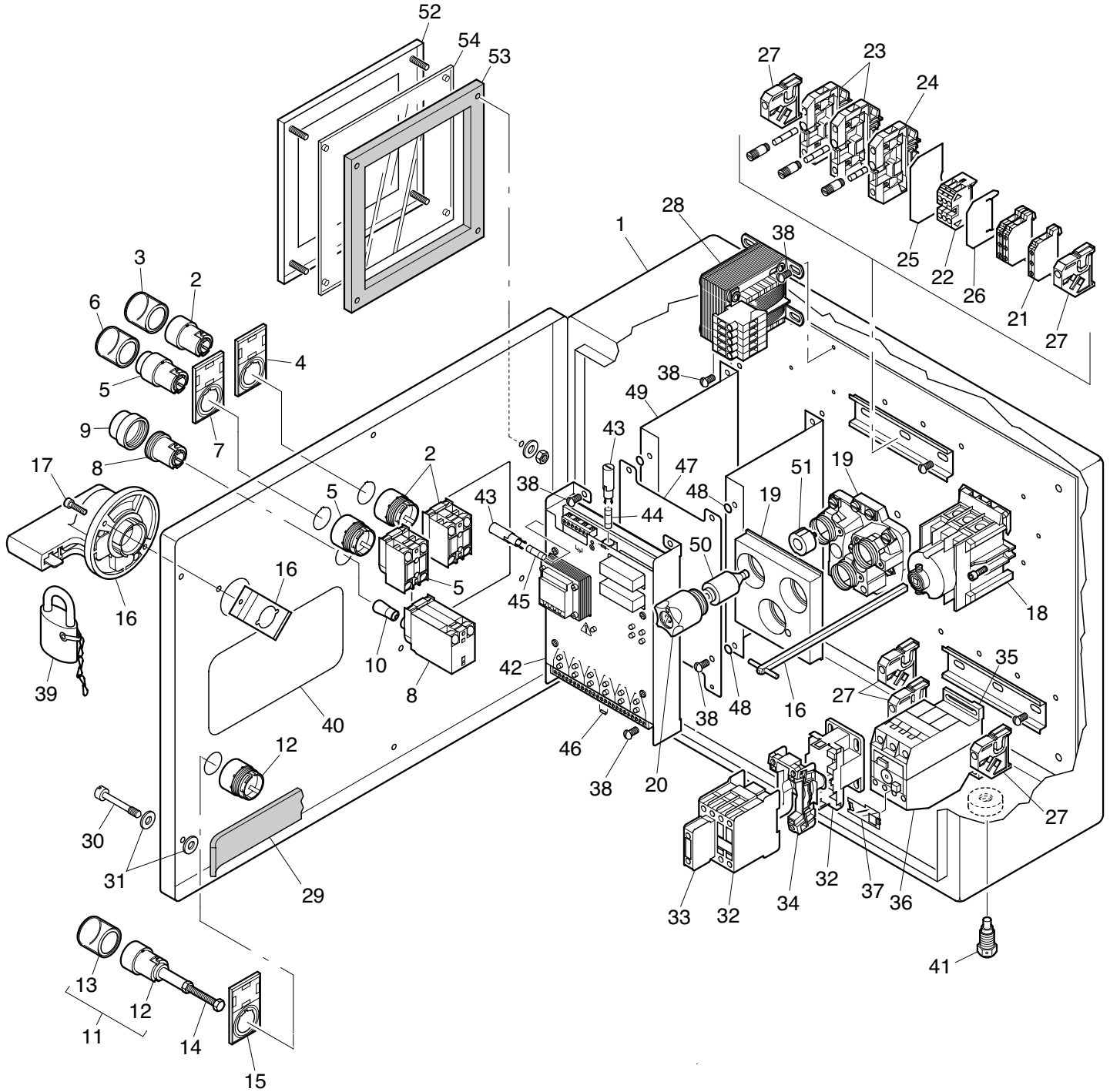

ITEM NO.	PART NO.	DESCRIPTION	QTY.
—	13707	IEC Electrical Assembly, (includes items 1–73)	1
1	13702	IEC Combination Starter, 22 amp., w/lugs, (includes items 2–35)	1
2	12740	Start Button Assembly, (includes item 3)	1
3	12748	Protective Cap, flush head, IEC	1
4	12742	Name Plate, (I) start, IEC	1
5	12741	Stop Button Assembly, (includes item 6)	1
6	12749	Protective Cap, extended head, IEC	1
7	12743	Name Plate, (O) stop, IEC	1
8	12757	Pilot Light, IEC, (includes items 9–10)	1
9	12758	Pilot Light Lens, IEC	1
10	12599	Bulb, pilot light, IEC	1
11	12747	Reset Button Assembly, IEC, (includes item 12–13)	1
12	12744	Reset Button, IEC	1
13	12748	Protective Cap, flush head, IEC	1
14	12745	Reset Extender, IEC	1
15	12746	Name Plate, reset, IEC	1
16	12774	Disconnect Switch Handle, IEC	1
17	12782	Machine Screw, 4mm x 16mm	2
18	12775	Disconnect Switch, IEC	1
19	13491	Fuse Base, 25 amp., (E27 thread)	1
20	13489	Screw Cap, (E27 thread)	3
21	12750	Earthing Terminal, IEC	3
22	12760	Terminal, IEC	3
23	12764	Fuse Terminal, 6.3 x 32 mm, IEC, (uses fuse 13675; includes item 25)	2
24	12763	Fuse Terminal, 5 x 20 mm, IEC, (uses fuse 13674; includes item 25)	1
25	*	Barrier and Spacer, IEC	1
26	*	Barrier, IEC	1
27	12751	End Anchor, IEC	5
28	*	Control Circuit Transformer	1
29	*	Door Gasket	72"
30	13596	Fastener for Enclosure	4
31	13602	Nylon Washer	8
32	12753	Contact, 22 A., IEC, (includes items 33–34)	1
33	12755	Front-Mount Auxiliary Contact, N.O.	1
34	12754	Coil, 110/120 volts, 50/60 Hertz, IEC	1
35	13677	Overload Base Adapter	1
36	*	Overload Relay	1
37	13678	Transparent Cover for Adjustment Dial	1
38	10625	Round Head Machine Screw, w/washer, 10-32 x 1/2"	10
39	13408	Padlock, with chain	1
40	13705	Wiring Diagram	1
41	11593	Breather/Drain, 1/4"	1
42	63737	**Amplifier, (includes items 43–46)	1
43	13673	Adapter	2
44	13671	Fuse, .630 amp.	1
45	13672	Fuse, .125 amp.	1
46	63755	Resistor, 22K	1
47	63747	Adapter Plate	1
48	12633	Rubber Washer	4
49	13561	Amplifier Bracket	2
50	*	Fuse	3
51	*	Fuse Adapter	3
52	13599	Window Replacement Kit, (includes items 53–54)	1
53	—	Window Gasket	1
54	—	Window	1

* Consult factory

** A retrofit assembly (part no. 63756) is required to adapt 63737 amplifier to machines currently using 63068 amplifier. Consult factory for further information.

Continued on page 93.

PARTS

Electrical Assembly (IEC)

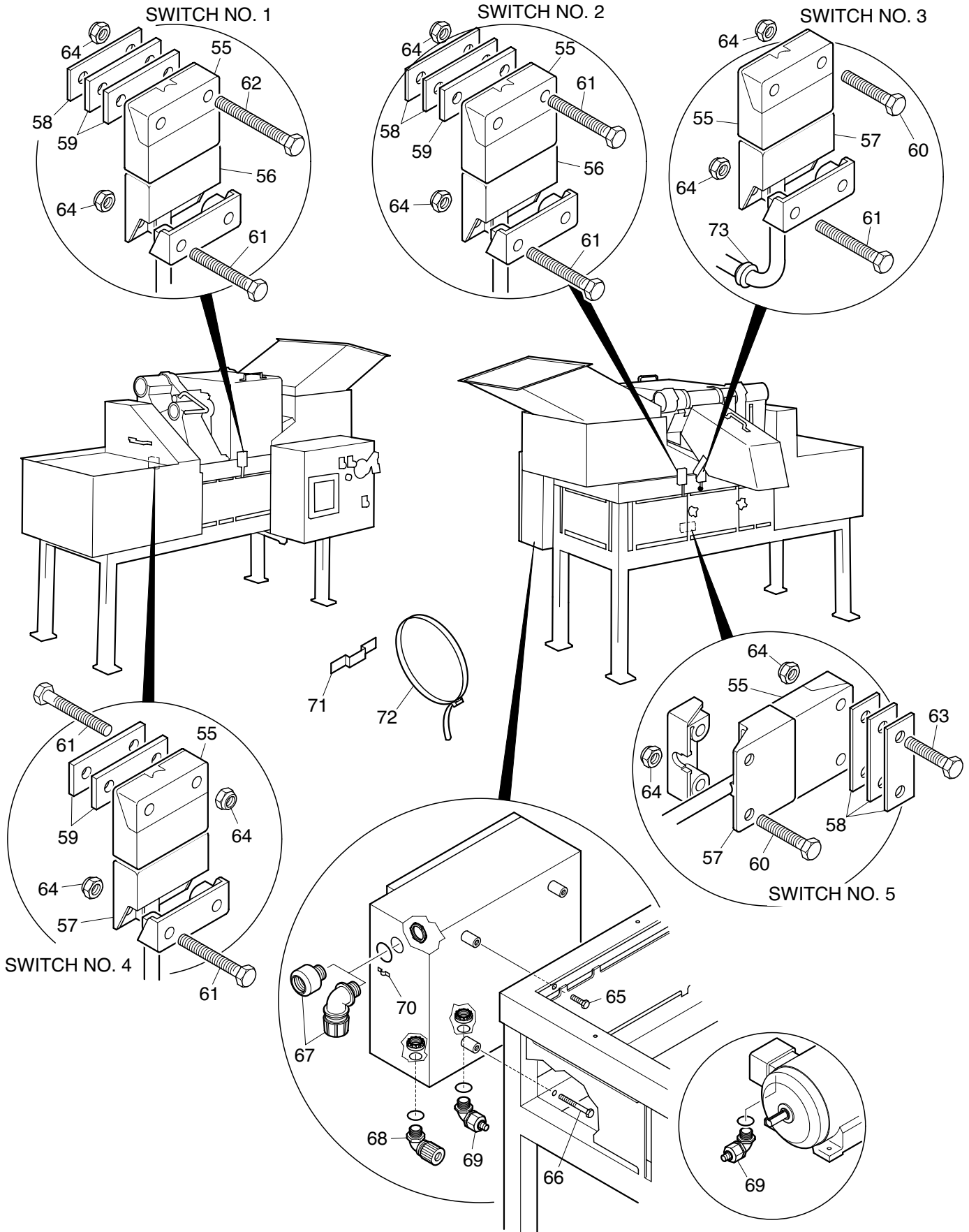

PARTS

Electrical Assembly (IEC)

Continued from page 91.

ITEM NO.	PART NO.	DESCRIPTION	QTY.
55	63741	Actuator	5
56	63738	Sensor, 6' lead	2
57	63739	Sensor, 12' lead.	3
58	63084	Spacer, 1/32"	6
59	63227	Spacer, 3/16"	5
60	10233	Hex Head Cap Screw, 10-24 x 1"	4
61	10348	Hex Head Cap Screw, 10-24 x 1-1/4"	12
62	10349	Hex Head Cap Screw, 10-24 x 1/2"	2
63	10351	Hex Head Cap Screw, 10-24 x 7/8"	2
64	10231	Hex Nut, locking, 10-24	20
65	10044	Hex Head Cap Screw, 5/16-18 x 5/8"	2
66	10053	Hex Head Cap Screw, 5/16-18 x 2-1/2"	2
67	11582	Conduit Hub	1
	11626	Cord Connector, 90°	1
68	11548	Cord Connector, 7/32", 90°	5
69	11614	Conduit Connector, 1/2", 90°	2
70	13424	Clip, chain	1
71	13465	Clip, cable tie	23
72	11513	Cable Tie	26
73	45426	Rubber Grommet	1

PARTS

Electrical Schematic (NEMA)

See the addendum for updated information

NEMA National Electrical Manufacturers Association

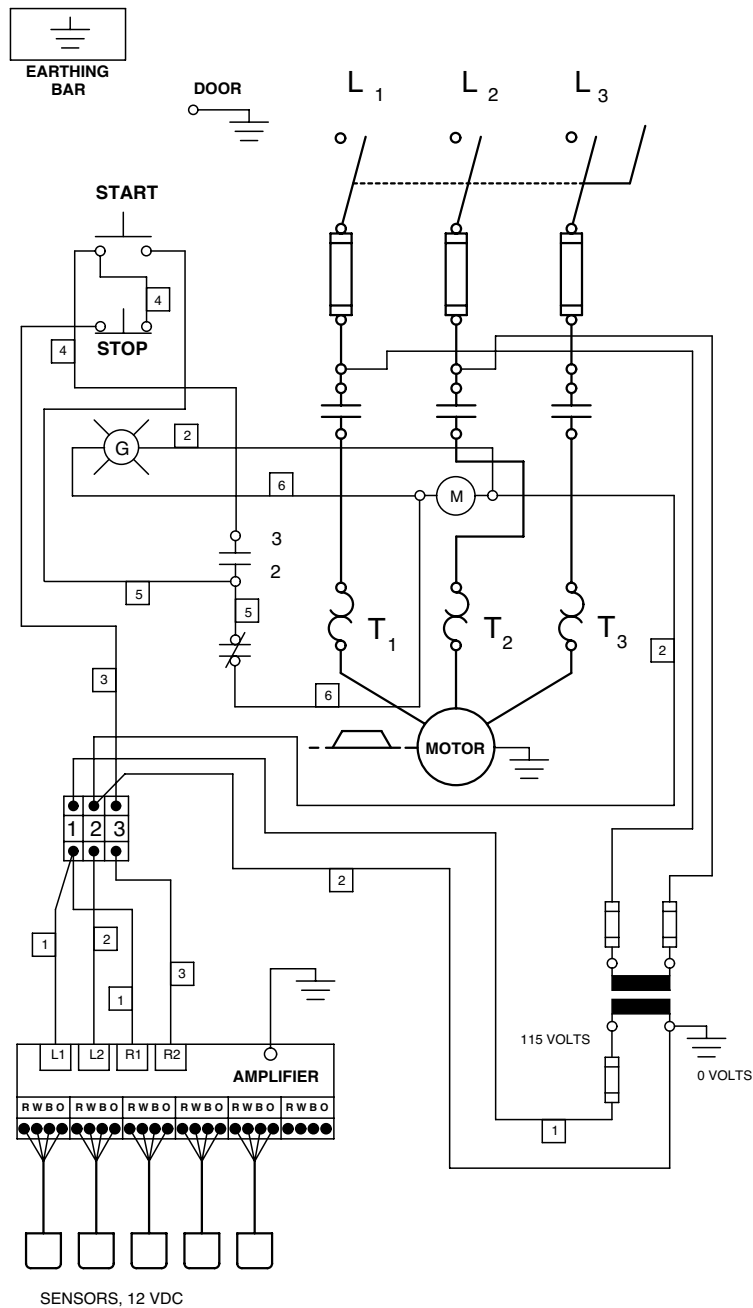

See the addendum
for updated information

PARTS

Electrical Schematic (IEC)

IEC International Electrical Commission

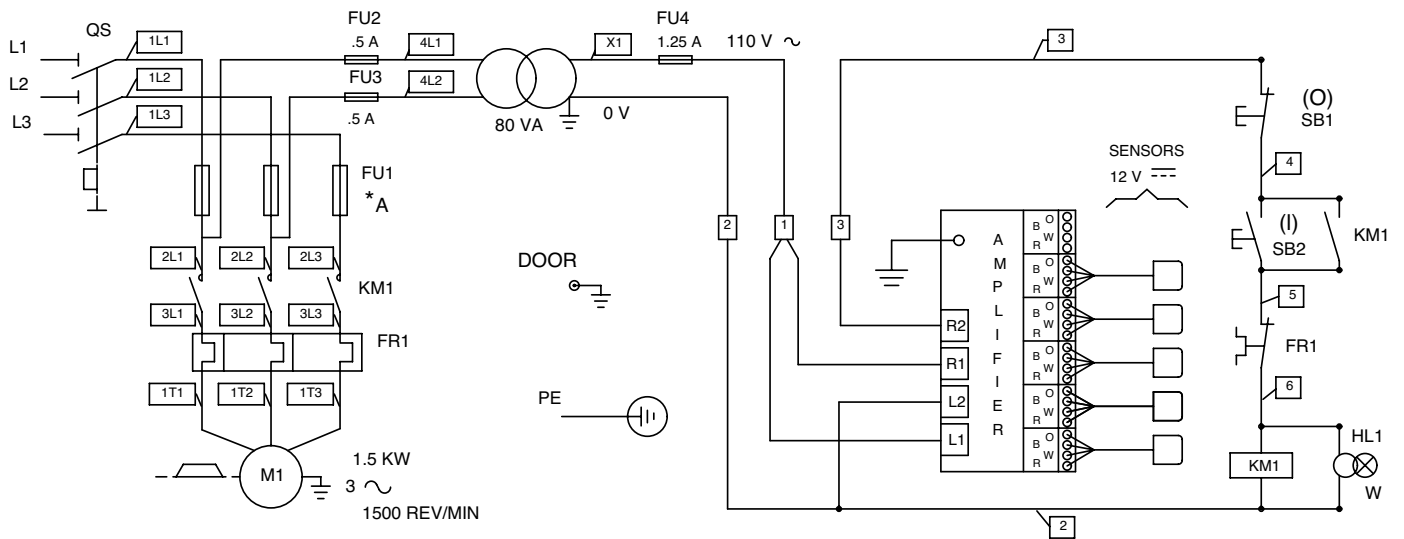

* See schematic inside starter enclosure for fuse amperage.

PARTS

Motor With Drive Parts

See the addendum
for updated information

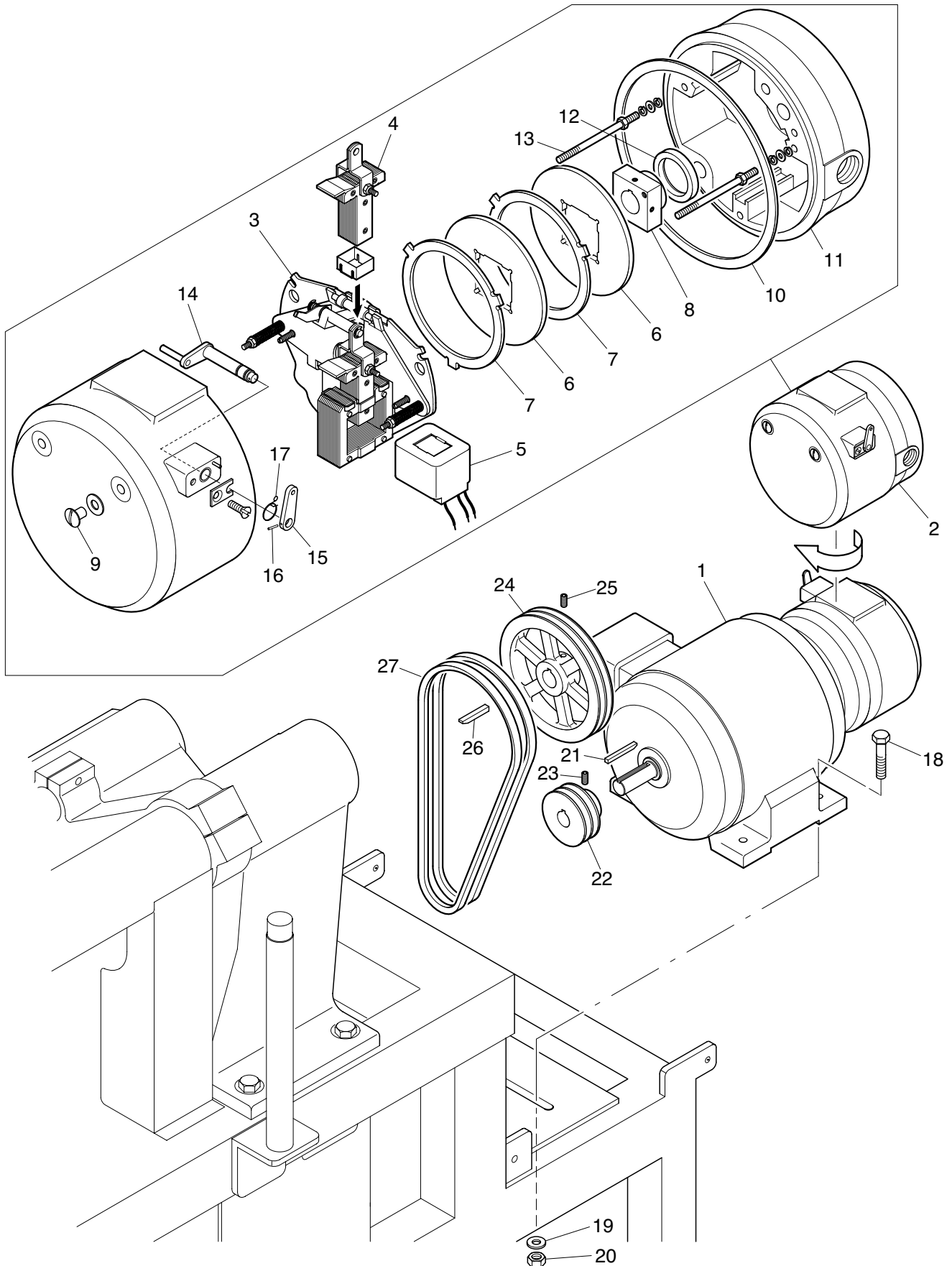

See the addendum
for updated information

PARTS

Motor With Drive Parts

ITEM NO.	PART NO.	DESCRIPTION	QTY.
1	†	Motor, with brake, 2 H.P., 184 frame, (includes item 2)	1
2	12700	Brake Assembly, 6 pound foot, 7/8" bore , (includes items 3–17)	1
	16934	Brake Assembly, 10 pound foot, 7/8" bore , (includes items 3–17)	1
3	12627	Support Plate Assembly, (includes item 4)	1
4	12668	Plunger, Link and Frame Assembly	1
5	12624	Solenoid Coil, 200-240 volts, (50/60 Hz.)	1
	12626	Solenoid Coil, 575 volts, (60 Hz., for use in Canada)	1
	12670	Solenoid Coil, 110 volts, (50/60 Hz., for use with stop/start station)	1
6	12628	Friction Disc	**
7	12629	Stationary Disc	**
8	12664	Hub and Set Screw Assembly, (6 pound foot brake, 7/8" bore)	1
	12671	Hub and Set Screw Assembly, (10 pound foot brake, 7/8" bore)	1
9	12666	Housing Nut with Gasket.	2
10	12669	Gasket, housing to end plate	1
11	12772	Endplate and Seal Assembly, 6 pound foot, (includes item 12)	1
	12771	Endplate and Seal Assembly, 10 pound foot, (includes item 12)	1
12	12709	Seal, endplate	1
13	12663	Housing Stud.	2
14	12674	Release Lever	1
15	12726	Release Handle	1
16	12661	Roll Pin, 1/16 x 1/2" long.	1
17	12665	Torsion Spring	1
18	10060	Hex Head Cap Screw, 3/8-16 x 1-1/2"	4
19	10270	Flat Washer, 3/8"	4
20	10249	Hex Nut, locking, 3/8-16	4
21	18067	Key, 3/16 square x 2"	1
22	13076	Pulley, 3.05 O.D., .875 I.D., 2 groove w/ set screw, 60 Hz., (includes item 23)	
1			
	13117	Pulley, 3.50 O.D., .875 I.D., 2 groove w/ set screw, 50 Hz., (includes item 23)	
1			
23	10504	Socket Set Screw, 5/16-18 x 3/8"	1
24	12219	Pulley, 7.25 O.D., 1.000 I.D., 2 groove w/ set screw, (includes item 25)	1
25	10504	Socket Set Screw, 5/16-18 x 3/8"	1
26	12229	Key, 1/4 x 1-3/4"	1
27	48285	"V" Belts, A-36, (set of 2)	1

† Consult factory.

** Use 2 for 6 pound foot brake and 3 for 10 pound foot brake.

PARTS

Machine Labels

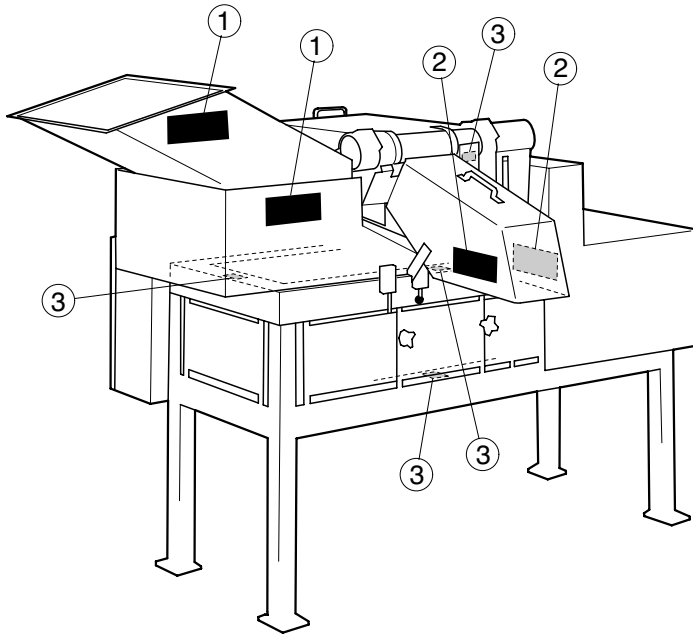

①  **DANGER**
DO NOT PUT HANDS INTO FEED OPENING.
PELIGRO
NO PONER LA MANO DENTRO DE LA ABERTURA DE ALIMENTACION.

②  **DANGER**
DO NOT PUT HANDS INTO OR UNDER DISCHARGE CHUTE.
PELIGRO
NO PONER LA MANO DENTRO O BAJO EL CONDUCTO DE DESCARGA.

③  **DANGER**
MACHINE IS UNGUARDED. REPLACE GUARD OR COVER.
PELIGRO
LA MAQUINA ESTA SIN PROTECCION. VOLVER A COLOCAR EL PROTECTOR O CUBIERTA.

④ **CAUTION**

MACHINE CONTAINS ROTATING PARTS SUCH AS SHARP KNIVES, PULLEYS, BELTS OR GEARS. NEVER RUN MACHINE WITH ANY GUARD OR COVER REMOVED, EVEN FOR CLEANING. TURN THE MACHINE OFF, DISCONNECT AND LOCK OUT POWER SOURCE BEFORE ATTEMPTING TO SERVICE OR REMOVE OBSTRUCTION. RUNNING MACHINE WITH ANY GUARD OR COVER REMOVED MAY RESULT IN SERIOUS INJURY OR AMPUTATION. READ AND UNDERSTAND INSTRUCTION MANUAL.

PRECAUCION

LA MAQUINA CONTIENE PIEZAS GIRATORIAS TALES COMO CUCHILLAS AFILADAS, POLEAS, CORREAS O ENGRANAJES. NUNCA HACER FUNCIONAR LA MAQUINA CON CUALQUIERA DE LOS PROTECTORES O CUBIERTAS RETIRADOS, INCLUSO PARA LIMPIARLA. APAGAR LA MAQUINA, DESCONECTAR Y BLOQUEAR EL SUMINISTRO ELECTRICO ANTES DE INTENTAR HACER UNA REPARACION O QUITAR UNA OBSTRUCCION. SE CORRE EL RIESGO DE SUFRIR GRAVES LESIONES O AMPUTACION SI SE HACE FUNCIONAR LA MAQUINA CON CUALQUIERA DE LOS PROTECTORES O CUBIERTAS FUERA DE SU LUGAR. LEER Y ENTENDER EL MANUAL DE INSTRUCCIONES.

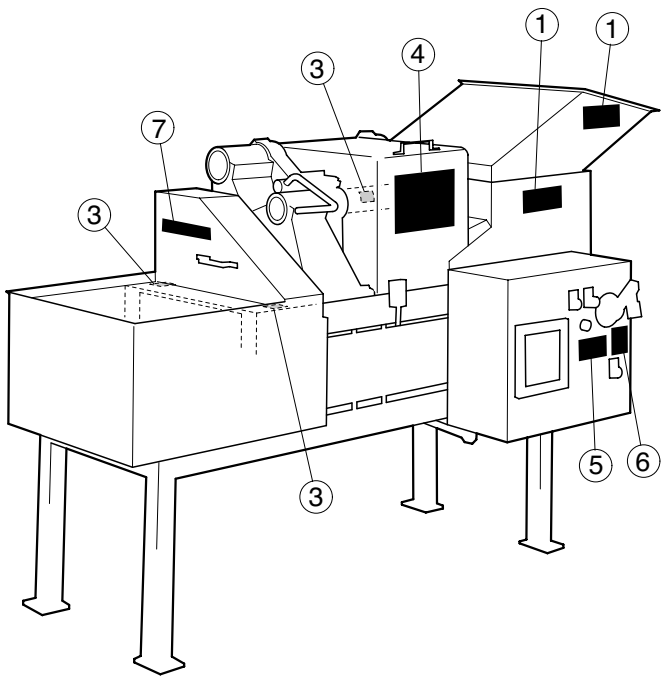

⑤  **DANGER**
MUST BE OPENED AND SERVICED BY QUALIFIED ELECTRICIAN ONLY. INSTALL TO MEET APPLICABLE CODES.
PELIGRO
DEBE SER ABIERTO Y REPARADO POR UN ELECTRICISTA CALIFICADO SOLAMENTE. INSTALAR DE ACUERDO A LOS CODIGOS CORRESPONDIENTES.

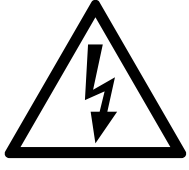
⑥  **XXX VOLTS** ~

⑦ **URSCHEL**

PARTS

Machine Labels

	①	②	③	④	⑤	⑥	⑦
ENGLISH	11662	11663	11665	11666	11667	*	11326
SPANISH	11662	11663	11665	11666	11667	*	11326
FRENCH (F)	11674	11675	11677	11678	11679	*	11326
GERMAN (Ge)	11681	11682	11684	11685	11686	*	11326
JAPANESE (J)	11688	11689	11691	11692	11693	*	11326
PORTUGUESE (Po)	11695	11696	11698	11699	11700	*	11326
ITALIAN (It)	11702	11703	11705	11706	11707	*	11326
SWEDISH (Sw)	11709	11710	11712	11713	11714	*	11326
DUTCH (Du)	11716	11717	11719	11720	11721	*	11326
CHINESE (Ch)	11724	11725	11727	11723	11728	*	11326
POLISH (Pol)	11730	11731	11733	11734	11735	*	11326
GREEK (Gr)	11737	11738	11740	11741	11742	*	11326
SERBO-CROATION (Sb)	11109	11110	11112	11108	11667	*	11326
RUSSIAN (Ru)	11744	11745	11747	11748	11749	*	11326
INDONESIAN (In)	11751	11752	11754	11755	11756	*	11326
FINNISH (Fi)	11758	11759	11761	11762	11763	*	11326
TURKISH (Tu)	11765	11766	11768	11769	11770	*	11326
HUNGARIAN (Hu)	11772	11773	11775	11776	11777	*	11326
DANISH (Da)	11793	11794	11796	11797	11798	*	11326
QUANTITY	4	2	7	1	1	1	1

* 200 VOLTS 12714
 208 VOLTS 12715
 220 VOLTS 12716
 230 VOLTS 12717
 240 VOLTS 12718
 380 VOLTS 12719
 400 VOLTS 12720
 415 VOLTS 12721
 440 VOLTS 12722
 460 VOLTS 12723
 575 VOLTS 12724

PARTS

Optional Parts

PART NO.	DESCRIPTION	APPLICATION
12550	Impeller, 7" opening, 6 blade, (Model G-A)	
12503	Impeller, 7" opening, 12 blade, (Model G-A)	
12478	Impeller, 10" opening, 3 blade, (Model G-A)	
12449	Impeller, 10" opening, 4 blade, (Model G-A)	
14045	Impeller, 10" opening, 4 blade, (Model GK-A)	
14063	Impeller, 10" opening, 8 blade, (Model GK-A)	
14070	Impeller, 10" opening, 12 blade, (Model GK-A)	
12356	Feed Hopper, 10" opening	Use with 10" opening impellers
25030	Slicing Knife	Slicing only
13245	Slicing Knife	For peaches
14047	Slicing Knife, (Model GK-A)	"V" cut
25501	Slicing Knife, crinkle, (Model GK-A)	Slicing only
13639	Slicing Knife, thin profile.	Slicing only, carrots
13222	Slice Guide	Slicing only
13128	Slice Guide, front	Julienne strip cutting
13129	Slice Guide, rear.	Julienne strip cutting
(see chart)	Slicing Knife Holder Assembly	For peaches
13071	Slicing Knife Holder	
(see chart)	Spring Plate	
13108	Screw (5 required)	

Circular Knife Size of Cut	Slicing Knife Holder Assembly	Spring Plate
1/4"	—	13692
3/8"	13335	13208
7/16"	13552	13553
1/2"	13109	13069
9/16"	13110	13111
.600"	13178	13169
5/8"	13150	13149

12462	Crosscut Knife, 9/32, 3/8 & 7/16" cut	For peaches
13246	Crosscut Knife, 1/2, 5/8, 3/4 & 7/8" cut	For peaches
12460	Crosscut Knife, 9/32, 3/8 & 7/16" cut, (Model GK-A).	"V" cut
14048	Crosscut Knife, 1/2, 5/8, 3/4 & 7/8" cut, (Model GK-A)	"V" cut
12686	Circular Knife, 4", wide serrations.	Aid product feed
13631	Slicing Knife Holder, 1/8", wide slot	Use with 12686
13619	Spacer, reduced diameter, 1"	For lettuce (use with-
13572	Spacer, reduced diameter, 1-1/2"	out stripper plate)
13323	Spacer, reduced diameter, 2"	
13276	Spacer, reduced diameter, 3"	
13638	Circular Knife, (use with special spacers, below)	For carrots
13635	Spacer, 1/8"	Use with 13638
13636	Spacer, 5/32"	Use with 13638
13637	Spacer, 3/16"	Use with 13638
13113	Stripper Plate, 5/32", julienne cut	
13701	Discharge Chute, long	

PART NO.	DESCRIPTION	APPLICATION
(see chart)	Slice Guide Roll Assembly, (includes following 10 items)	Replaces crosscut spindle when cutting strips
13123	Collar, slice guide roll	
10094	Socket Head Cap Screw, 1/4-20 x 1" (3 required)	
13070	Gear, 32 teeth, stainless steel, (includes following item)	
13061	Bearing, for 13070 gear	
(see chart)	Slice Guide Roll	
27061	Bushing, 1 x 1.25 x 1.75, (2 required)	
37063	Locating Collar	
10141	Socket Set Screw, 5/16-18 x 1/2"	
13075	Shaft, slice guide roll	
11402	Grease Fitting, 1/8", 65°	

Circular Knife Size of Cut	Slice Guide Roll Assembly	Slice Guide Roll
5/32"	13127	13124
3/16"	13127	13124
1/4"	13122	13119
5/16"	13133	13130

13438	*Feed Spindle Assembly For Slaw, (includes following 10 items)	For cutting slaw
13123	Collar, slice guide roll	
13075	Shaft, slice guide roll	
37063	Locating Collar	
13437	Spindle Assembly, feed, for slaw	
13436	Circular Spindle For Slaw	
13439	Feed Disc (13 required)	
16107	Spacer, 1/2" (12 required)	
16390	Nut	
13070	Gear, 32 teeth, stainless steel	
10094	Socket Head Cap Screw, 1/4-20x1" (3 required)	
13128	Slice Guide, front	Use following parts with 13438
13129	Slice Guide, rear	
13016	Slicing Knife Holder, 1/8"	
13676	Circle Knife Spindle Assembly, 1/8", (see Circular Knife Spindle Assembly, page 85)	
13316	Stripper Plate, 1/8" slaw cut	
17250	Pulley, 5.00 O.D., .875 I.D., 2 groove w/set screw	
15273	"V" Belts, A-39, set of two	

* Use feed spindle in place of crosscut spindle and set slice thickness at 1/16". Use 25030 slicing knife. Impeller speed is 312 RPM using pulley and belts listed above. **DO NOT RUN CROSSCUT SPINDLE AT THIS SPEED!**

Optional parts continued on page 102.

PARTS

Optional Parts

Continued from page 101.

ITEM NO.	PART NO.	DESCRIPTION	QTY.
1	13649	Frame, for plate casters	1
–	12384	Plate Casters, set of four, (includes items 2–5)	1
2	12477	Swivel Caster, plate type	2
3	12528	Rigid Caster, plate type	2
4	10058	Hex Head Cap Screw, 3/8-16 x 1"	16
5	10249	Hex Nut, locking, 3/8-16.	16

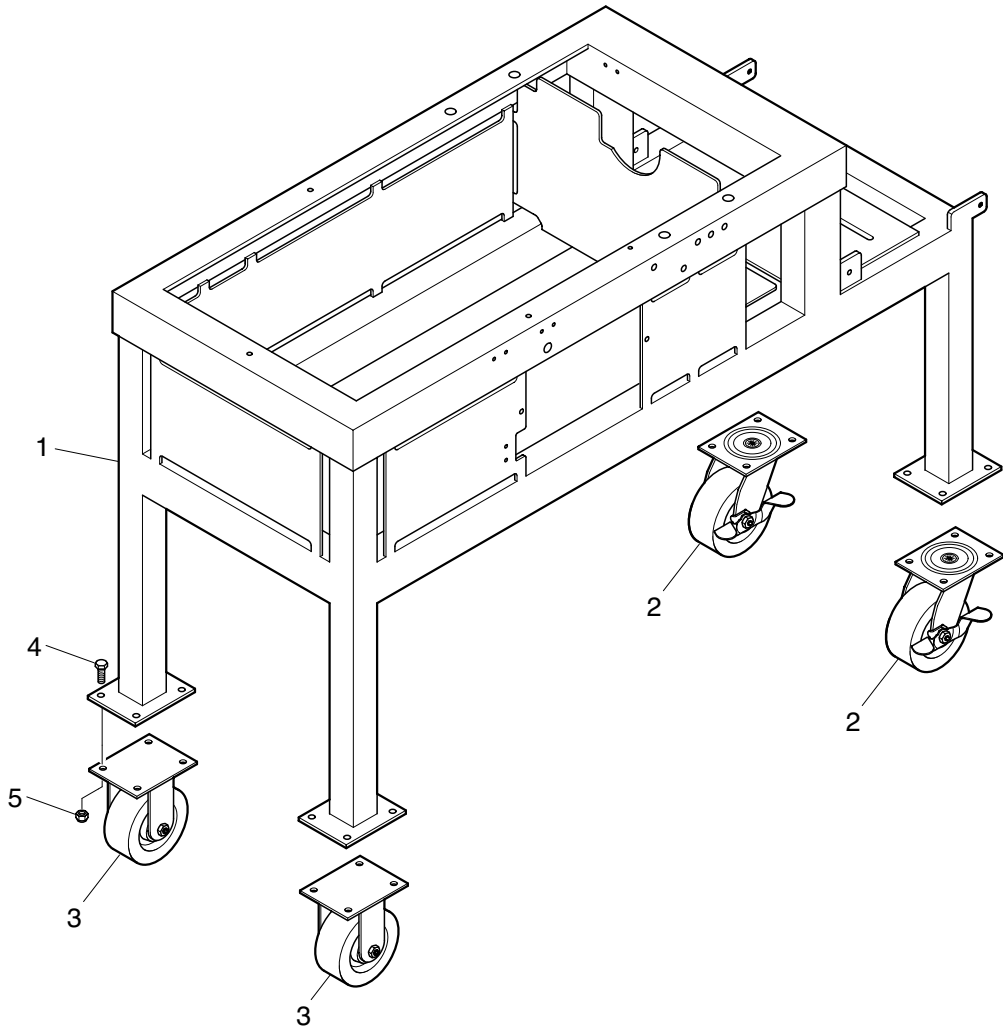

PARTS

Dimensional Drawing

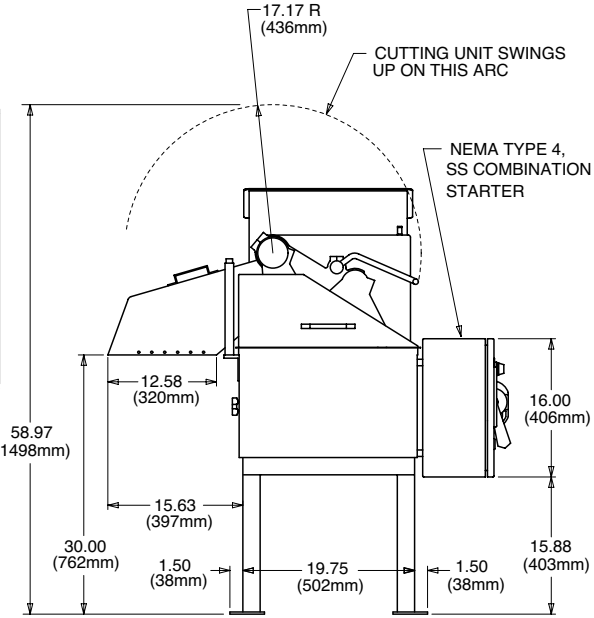
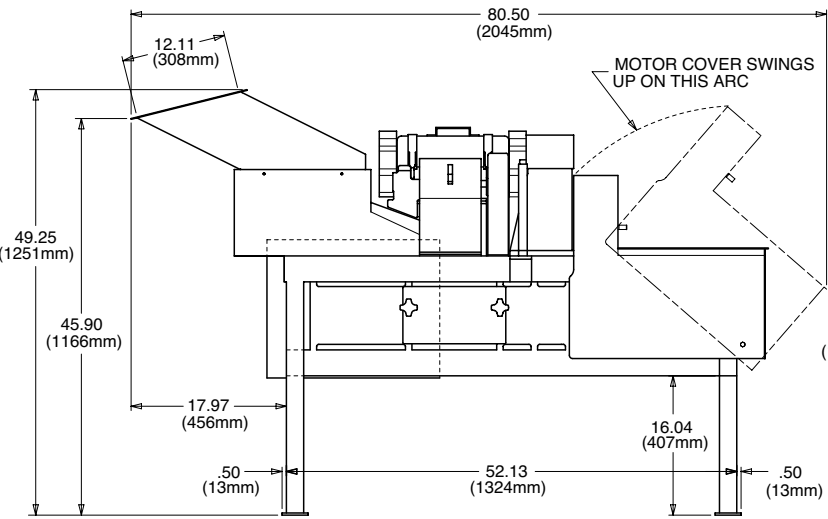
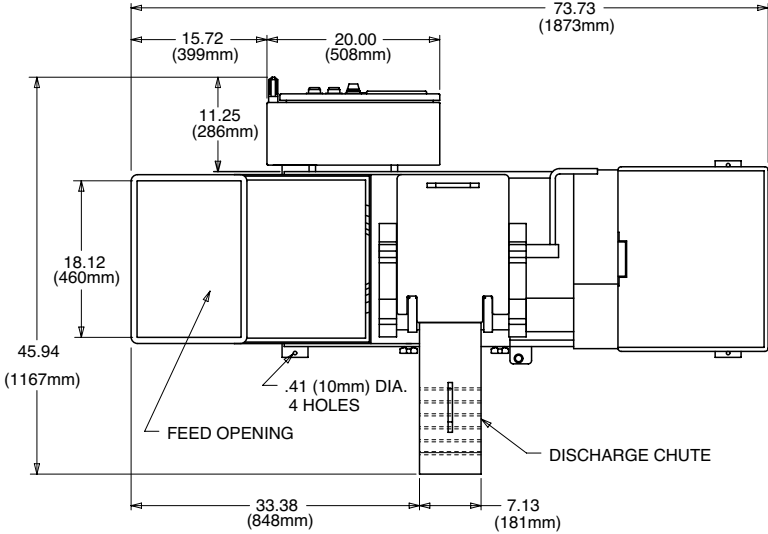

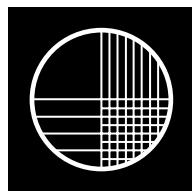

URSCHEL

LABORATORIES INCORPORATED

**Designers and manufacturers of
precision size reduction equipment.**

U.S.A. 2503 Calumet Avenue
 P.O. Box 2200
 Valparaiso, IN 46384-2200
 Tel: 219-464-4811
 Fax: 219-462-3879
 e-mail: info@urschel.com
 web site: <http://www.urschel.com>

With subsidiaries and sales offices in principal cities worldwide.