

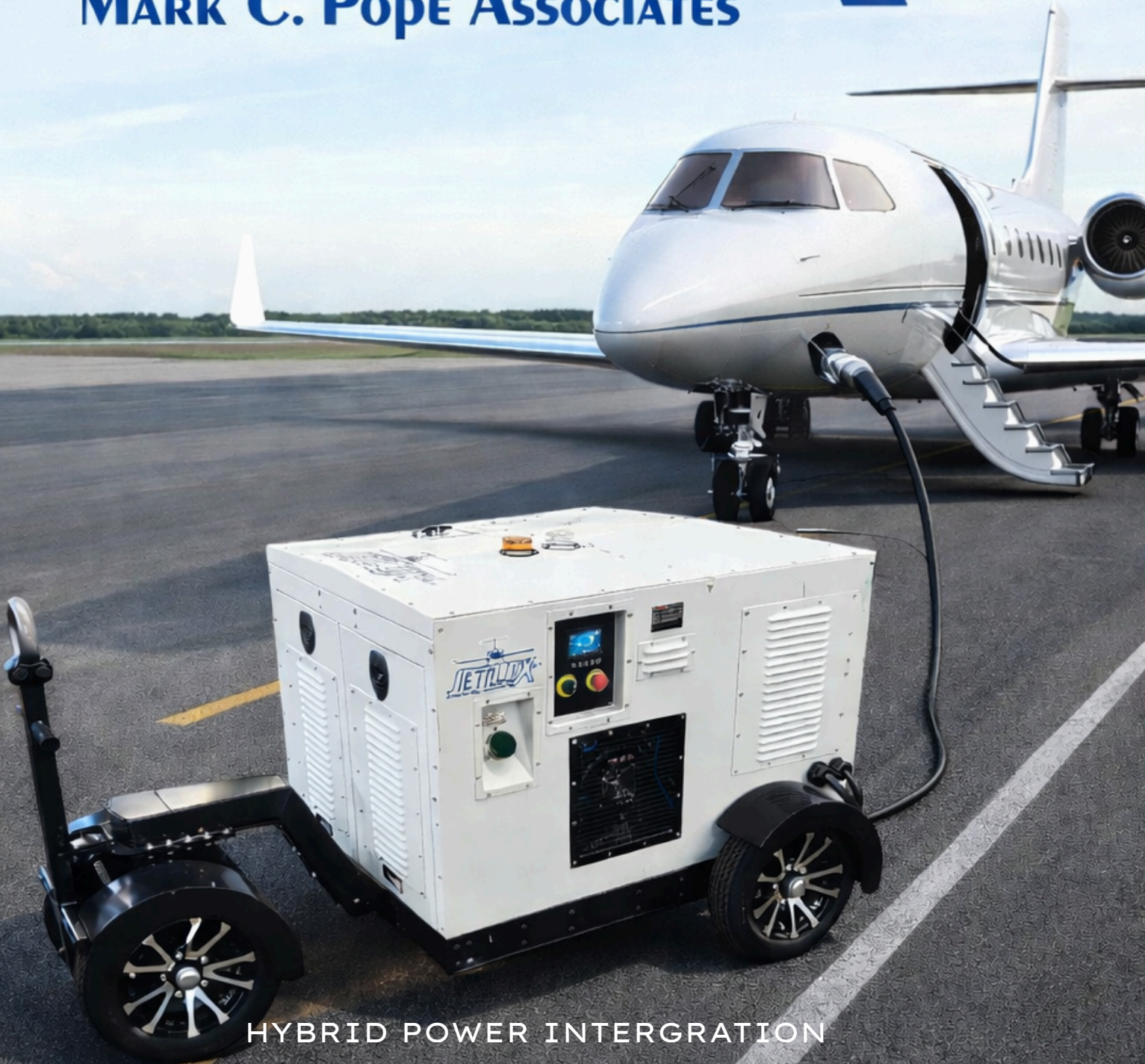

JETLUX^{28.5}

MARK C. POPE ASSOCIATES



HYBRID POWER INTERGRATION

Call Mark C. Pope Today For A Demonstration. 1-888-230-9367

www.markc pope.com

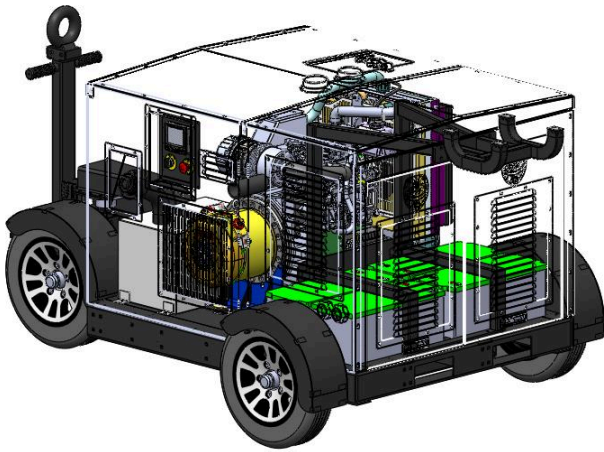

Built for FBOs, MROs, Regional Airlines, Flight Departments and Military Applications

- Faster aircraft turns
- Lower fuel and maintenance costs
- Reduced engine runtime and wear
- Clean, stable aircraft power
- Designed for real-world ramp operations

Clean Power. Professional Operations.

Deliver dependable power with a GPU designed specifically for modern FBO and corporate aviation environments. The JetLux™ 28.5V Ground Power Unit combines proven Kubota diesel reliability with advanced hybrid technology to deliver power only when demanded—reducing fuel consumption, noise, and long-term operating costs.

JetLux™ vs Traditional GPUs

Operational Advantage	JetLux™ 28.5V GPU	Traditional GPU
Power Delivery	Hybrid, demand-based	Constant engine run
Fuel Consumption	Less than 1gph	High
Engine Wear	Minimized	Continuous
Noise	67-74db	Higher
Voltage Stability	Consistent, Clean	Fluctuations

Technical Specifications

Output Voltage	28.5V DC
Continuous Output	450 Amps
Peak Output	2,000 Amps
Engine	Kubota 1.1L, 3 Cylinder Diesel
Horsepower	23.9 HP
Cooling	Water-Cooled
Emissions	EPA / CARB Tier 4
Cooling Rating	122°F / 50°C
4 - 159ah Batteries	MCP Carbon Nano 159ah Gel Bloc
Trailer	Heavy Duty Metal Enclosure - Pintle Ring
Dimensions	97.8" L X 60" W X 47.9" H - 1700lbs

Key Standard Features

Kubota® Tier 4 Diesel Engine – 1.1L, 3-cylinder, 23.9 HP

Hybrid Power System – Reduced runtime, efficient peak handling

Carbon Nano Gel Batteries – Maintenance-free, instant power, continuous charging allows multiple engine starts.

Continuous Power - Provides Power even if Engine Stops to Prevent Turbine Hot Starts and Damage to Aircraft

Simple Operator Interface – clear controls

Output Beacon - Signals Power Out

Fuel Monitoring Beacon – Prevents service interruptions

Safety Contactor Output – Cables energized only when active

Heavy-Duty Trailer and Enclosure – 3" pintle ring, self-engaging park brake, towable, but easy to hand push.

Compact Design - protects aircraft from potential damage.

Warranty - 6 Month Travel, 1 Year Labor, 2 Year Parts / Batteries

Simple Soft Button Operation



Easy Control Display for one touch start and operation

Electrical Performance

- 28.5V DC Aircraft Power
- 450 Amp Continuous / 2,000 Peak
- Hybrid Power Integration
- 4 - MCP - Carbon Nano Gel Bloc (maintenance free) Batteries That Offers Stable Consistent Voltage
- Over Load Protection - High Voltage Shutdown

Safety Features

- Extended Idle Shutdown
- Water In Fuel Shutdown
- Low Coolant Shutdown
- Air Filter Restriction Shutdown
- Low Oil Pressure Shutdown
- High Battery Voltage Shutdown
- Overload Aircraft Protection
- Diagnostic Reporting
- Emergency Stop Button

1-888-230-9367 www.markc pope.com