

## 3M-Matic™ Random Case Sealer 7000r Pro



**7000r**  
*Pro*

Consistent.  
Reliable.  
Tough.

### **And now, better than ever.**

Today, companies need to be fast and flexible in every phase of their operations—and that includes end-of-line packaging. The 3M-Matic™ Random Case Sealer 7000r Pro gives manufacturers and distributors from every industry the packaging flexibility and speed to stay one step ahead of the competition.

This advanced technology case sealer is an ideal solution for top and bottom sealing of random-sized cases. Automatically adjusting to both case height and width, the 3M-Matic™ Random Case Sealer 7000r Pro can handle up to 24 different case sizes per minute.

***3M-Matic™ Case Sealers: Consistent. Reliable. Tough.***

**3M**

# Long lasting. Low maintenance. Trusted reliability.

## Innovative Features

- 3M™ AccuGlide™ 3 Taping Heads ensure reliable application of tape without box damage
- Auxiliary offset taping head position provides more flexibility in sealing shorter boxes
- Interchangeable 2-inch or 3-inch taping heads maximize production flexibility
- Rugged, dual-extruded columns allow for smooth, incremental adjustments to case heights
- Photo eye detection for box centering quickly responds to cartons of different widths
- Electro-mechanical height adjustment delivers precision performance and durability

## Standard Features

- Top and bottom belt drive system
- Centrally located emergency stop
- Dual masts
- Infeed conveyor

**Options:** Exit conveyor, locking casters, low tape indicator, light indicator

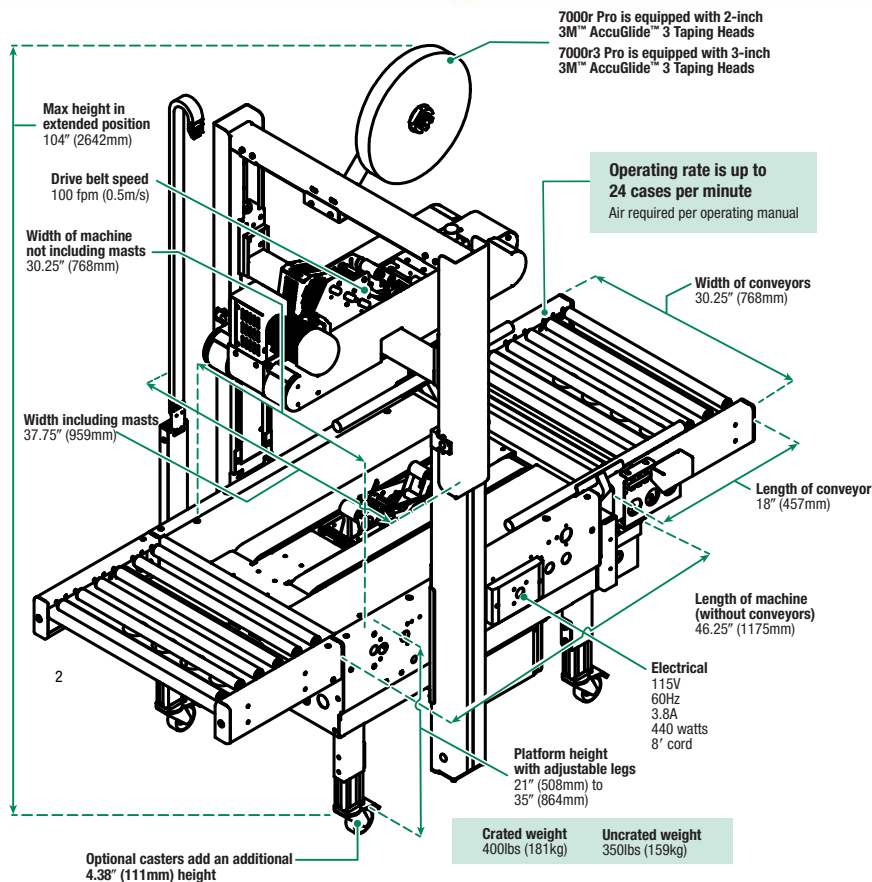

Box Dimensions for 7000r Pro and 7000r3 Pro Machines: Inches (mm)

|                            | Length  | Width      | Height <sup>1</sup>      |                       |                       |
|----------------------------|---------|------------|--------------------------|-----------------------|-----------------------|
|                            |         |            | Standard Position        | Standard Position     | Offset Position       |
|                            |         |            | Standard Tape Leg Length | Short Tape Leg Length | Short Tape Leg Length |
| <b>Minimum<sup>2</sup></b> | 6 (152) | 6.5 (165)  | 4.25 (108)               | 3.75 (95)             | 2.75 (70)             |
| <b>Maximum<sup>3</sup></b> | N/L     | 26.5 (673) | 26 (660)                 | 25.5 (648)            | 23.75 (603)           |

<sup>1</sup> Requires a column adjustment for case heights lower than 4.25" or higher than 28".

<sup>2</sup> Minimum case height of 1.5" requires LHB taping heads in 1-3/8" tape leg position and 78 fpm belt speed. Note: Case heights lower than 3.25" require a minimum case width of 12".

<sup>3</sup> Maximum case height of 36" can be obtained by moving the columns and upper assembly to the upper position. Minimum will be 14.625".

Learn more about 3M's full line of case sealing solutions at [3M.com/3M-Matic](http://3M.com/3M-Matic)

**Product Use:** User is responsible for determining whether the product is fit for a particular purpose and suitable for user's method of application.

**Warranty and Limited Remedy:** THE FOLLOWING WARRANTIES ARE MADE IN LIEU OF ALL OTHER WARRANTIES, EXPRESS OR IMPLIED, INCLUDING, BUT NOT LIMITED TO THE IMPLIED WARRANTY OF MERCHANTABILITY, THE IMPLIED WARRANTY OF FITNESS FOR A PARTICULAR PURPOSE AND ANY IMPLIED WARRANTY ARISING OUT OF A COURSE OF DEALING, A CUSTOM OR USAGE OF TRADE: 3M sells its 3M-Matic™ Random Case Sealer 7000r Pro with the following warranties: 1) The Taping Head knife blades, springs and rollers will be free from all defects for ninety (90) days after delivery. 2) All other Taping Head parts will be free from all defects for three (3) years after delivery. 3) All other parts will be free from all defects for two (2) years after delivery. Please refer to individual data pages for additional details and exceptions. If any 3M-warranted part is proved to be defective within its warranty period, then the exclusive remedy and 3M's and seller's sole obligation shall be, at 3M's option, to repair or replace the part, provided the defective part is returned immediately to 3M's factory or an authorized service station designated by 3M. A part will be presumed to have become defective after its warranty period unless the part is received or 3M is notified of the problem no later than five (5) calendar days after the warranty period. If 3M is unable to repair or replace the part within a reasonable time, then 3M, at its option, will replace the equipment or refund the purchase price. 3M shall have no obligation to provide or pay for the labor required to install the repaired or replacement part. 3M shall have no obligation to repair or replace (1) those parts failing due to operator misuse, carelessness, or due to any accidental cause other than equipment failure, or (2) parts failing due to non-lubrication, inadequate cleaning, improper operating environment, improper utilities or operator error. **Limitation of Liability:** 3M and seller shall not be liable for direct, indirect, special, incidental or consequential damages based upon breach of warranty, breach of contract, negligence, strict liability or any other legal theory. The foregoing Warranty and Limited Remedy and Limitation of Liability may be changed only by a written agreement signed by authorized officers of 3M and seller.