



Alvey[®] 881 Palletizer

MACHINE SERIAL NUMBER: 01-EK228118

ELECTRICAL DRAWINGS

Contents

1. Drawing Index
2. Power Diagram
3. Control Voltage Schematics
4. Connection Diagram
5. Main Control Enclosure Layout
6. Main Control Station Wiring
7. Bill of Materials

This manual was developed in adherence to the
PMMI Technical Documentation Content and Style Guide.

Copyright © 2010 Intelligrated[®]

No part of this manual may be reproduced, stored in a retrieval system, or transmitted in any form or by any means electronic, mechanical, photocopying, recording, or otherwise, without the prior written permission of Intelligrated[®]. All rights reserved.

To Order Reprints of this manual call **1-800-535-2555**, select the Parts Department, and ask for part number **P/N 01EK228118/9302**.

(This page intentionally left blank.)



| SEG | REL DATE | DRAWING NUMBER | DRAWING TITLE | REV | DATE |
|-----|----------|----------------|--|-----|------|
| 401 | 1/13/10 | EK228L01CD/001 | CONNECTION DIAGRAM | 0 | - |
| 401 | 1/13/10 | EK228L01CD/002 | CONNECTION DIAGRAM | 0 | - |
| 401 | 1/13/10 | EK228L01CD/003 | CONNECTION DIAGRAM | 0 | - |
| 401 | 1/13/10 | EK228L01CD/004 | CONNECTION DIAGRAM | 0 | - |
| 401 | 1/13/10 | EK228L01CD/005 | CONNECTION DIAGRAM | 0 | - |
| 401 | 1/13/10 | EK228L01CD/006 | POWER FLEX 40 PARAMETERS | 0 | - |
| 401 | 1/13/10 | EK228L01CD/007 | POWER FLEX 70 PARAMETERS | 0 | - |
| 401 | 1/13/10 | EK228L01CD/008 | CONNECTION DIAGRAM | 0 | - |
| 401 | 1/13/10 | EK228L01CD/009 | CONNECTION DIAGRAM | 0 | - |
| | | | | | |
| | | | | | |
| | | | | | |
| 401 | 1/13/10 | EK228L01EN/001 | MOTOR CONTROL ENCLOSURE LAYOUT | 0 | - |
| 401 | 1/13/10 | EK228L01EN/002 | MOTOR CONTROL ENCLOSURE DOOR SIGNS | 0 | - |
| 401 | 1/13/10 | EK228L01EN/003 | MOTOR CONTROL PANEL LAYOUT | 0 | - |
| 401 | 1/13/10 | EK228L01EN/004 | MOTOR CONTROL PANEL TEMPLATE | 0 | - |
| 401 | 1/13/10 | EK228L01EN/005 | MOTOR CONTROL PANEL TERMINAL LIST | 0 | - |
| 401 | 1/13/10 | EK228L01EN/006 | MOTOR CONTROL PANEL TERMINAL LIST | 0 | - |
| 401 | 1/13/10 | EK228L01EN/007 | PLC CONTROL ENCLOSURE LAYOUT | 0 | - |
| 401 | 1/13/10 | EK228L01EN/008 | PLC CONTROL ENCLOSURE DOOR SIGNS | 0 | - |
| 401 | 1/13/10 | EK228L01EN/009 | PLC CONTROL PANEL LAYOUT | 0 | - |
| 401 | 1/13/10 | EK228L01EN/010 | PLC CONTROL PANEL TEMPLATE | 0 | - |
| 401 | 1/13/10 | EK228L01EN/011 | PLC CONTROL PANEL TERMINAL LIST | 0 | - |
| 401 | 1/13/10 | EK228L01EN/012 | PLC CONTROL PANEL TERMINAL LIST | 0 | - |
| 401 | 1/13/10 | EK228L01EN/013 | PLC CONTROL PANEL TERMINAL LIST | 0 | - |
| 401 | 1/13/10 | EK228L01EN/014 | BRAKE CONTROL ENCLOSURE | 0 | - |
| 401 | 1/13/10 | EK228L01EN/015 | DYNAMIC BRAKE PANEL LAYOUT | 0 | - |
| | | | | | |
| | | | | | |
| | | | | | |
| 401 | 1/13/10 | EK228L01CS/001 | MAIN CONTROL STATION LAYOUT AND WIRING | 0 | - |
| 401 | 1/13/10 | EK228L01CS/002 | MAIN CONTROL STATION DIMENSIONS (1of2) | 0 | - |
| 401 | 1/13/10 | EK228L01CS/003 | MAIN CONTROL STATION DIMENSIONS (2of2) | 0 | - |
| 401 | 1/13/10 | EK228L01CS/004 | DISCHARGE CONTROL STATION LAYOUT | 0 | - |
| 401 | 1/13/10 | EK228L01CS/005 | DISCHARGE CONTROL STATION WIRING | 0 | - |
| 401 | 1/13/10 | EK228L01CS/006 | DISCHARGE E-STOP STATION A | 0 | - |
| 401 | 1/13/10 | EK228L01CS/007 | SLIPSHEET DISPENSER CONTROL STATION | 0 | - |
| | | | | | |
| | | | | | |
| | | | | | |
| | | | | | |
| 401 | 1/13/10 | EK228L01BM001 | MCP BILL OF MATERIAL | 0 | - |
| 401 | 1/13/10 | EK228L01BM002 | PCP BILL OF MATERIAL | 0 | - |
| 401 | 1/13/10 | EK228L01BM003 | BCP BILL OF MATERIAL | 0 | - |
| 401 | 1/13/10 | EK228L01BM004 | CSM BILL OF MATERIAL | 0 | - |
| 401 | 1/13/10 | EK228L01BM005 | CSD BILL OF MATERIAL | 0 | - |
| 401 | 1/13/10 | EK228L01BM006 | CSDA BILL OF MATERIAL | 0 | - |
| 401 | 1/13/10 | EK228L01BM007 | CSSS BILL OF MATERIAL | 0 | - |
| | | | | | |
| | | | | | |
| 401 | 1/13/10 | EK228L01BM401S | SEGMENT 401 B.M. | 0 | - |

| | | | | | | | | | | |
|-----|------|-------------|----|---|----------|---|-------------|----------------|------|---------|
| REV | DATE | DESCRIPTION | BY |  | CUSTOMER | DIAGEO NORTH AMERICA INC. RELAY, MD. | BY | HEDDERICH | DATE | 1/13/10 |
| | | | | | TITLE | DRAWING INDEX | DRAWING NO. | EK228L01DX/002 | SHT | 002 |

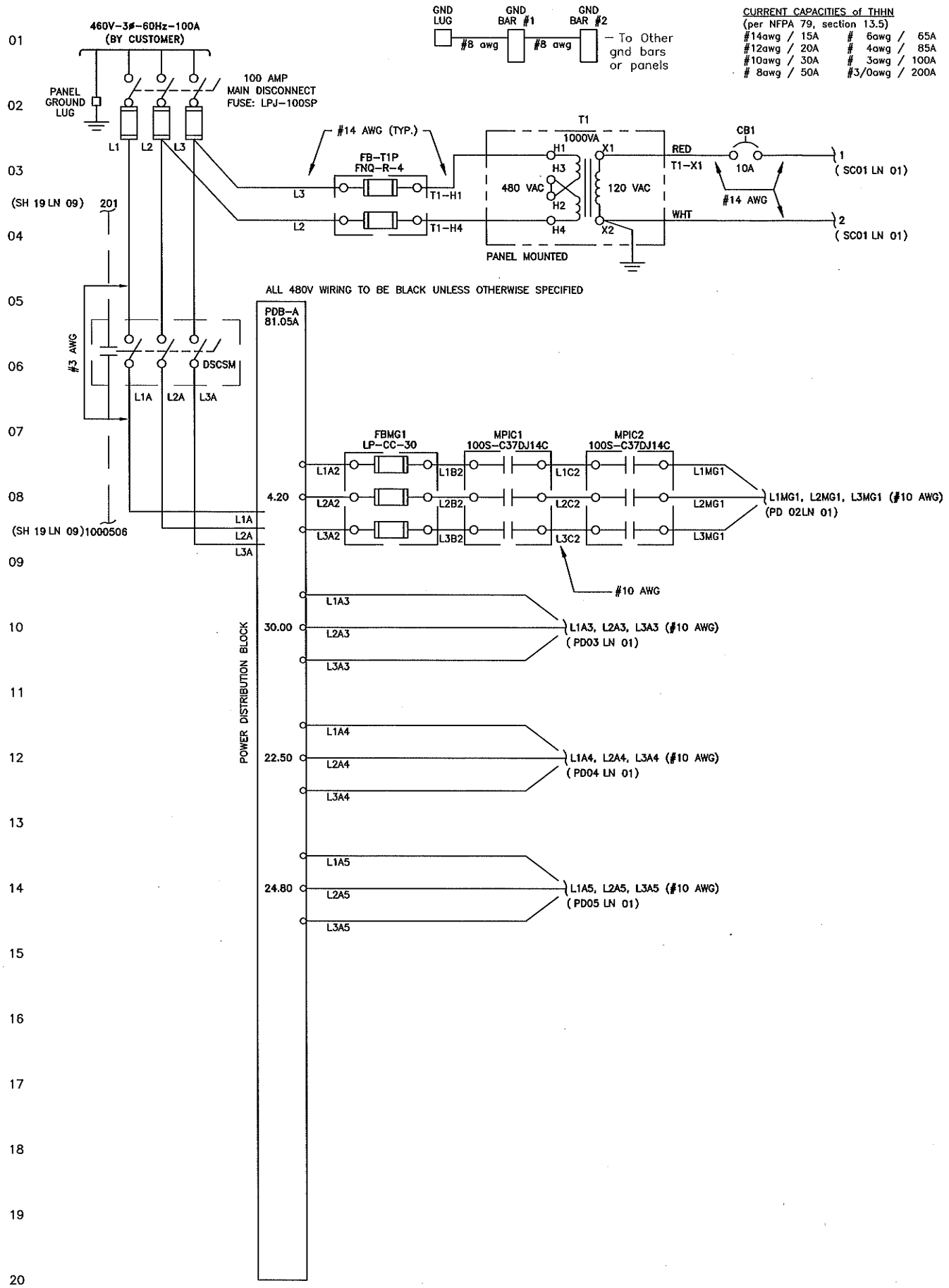

| | | | | | | | | | |
|-----|------|-------------|----|----------|---|-------------|----------------|------|---------|
| REV | DATE | DESCRIPTION | BY | CUSTOMER | DIAGEO NORTH AMERICA INC. RELAY, MD. | BY | HEDDERICH | DATE | 1/13/10 |
| | | | | TITLE | POWER DIAGRAM | DWG NO | EK228L01PD000A | SRT | 001 |
| | | | | | | DRAWING NO. | EK228L01PD/001 | | |



L1MG1, L2MG1, L3MG1 (#10 AWG)
(PD 01 LN 08)

01

4.20A

02

03

04

05

06

07

08

09

10

11

12

13

14

15

16

17

18

19

20

(XX LN XX)
L1A2, L2A2, L3A2

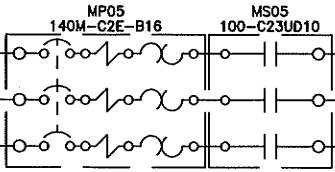

05T3
05T2
05T1

LAYER TABLE



HP: 1.0
FLA: 1.50
MFG: BALDOR

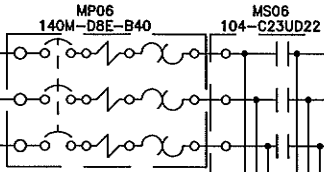

06T3
06T2
06T1

APRON



HP: 2.0
FLA: 2.70
MFG: BALDOR/SE

| | | | | | | | | | | | |
|-----|--|------|-------------|----|--|----------|---|----------------|----------------|-------|---------|
| REV | | DATE | DESCRIPTION | BY | | CUSTOMER | DIAGEO NORTH AMERICA INC. RELAY, MD. | BY | HEDDERICH | DATE | 1/13/10 |
| | | | | | | TITLE | POWER DIAGRAM | CAD NO. | EK228L01PD000A | SHEET | 002 |
| | | | | | | | DRAWING NO. | EK228L01PD/002 | | | |

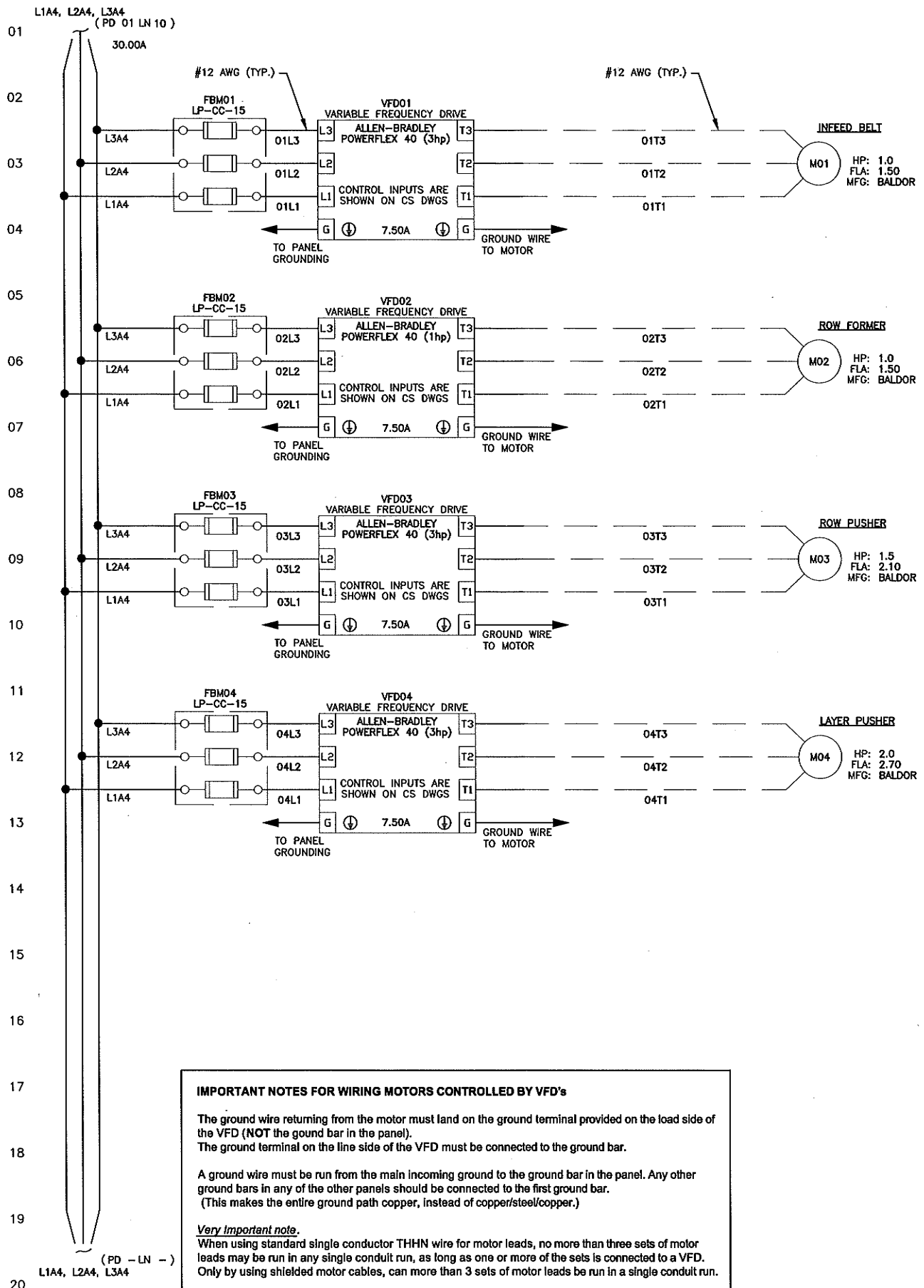

| | | | | | | | |
|-----|------|-------------|----|--|--|--------------------------------------|------------------------|
| REV | DATE | DESCRIPTION | BY | | CUSTOMER DIAGEO NORTH AMERICA INC. RELAY, MD. | BY HEDDERICH | DATE 1/13/10 |
| | | | | | TITLE POWER DIAGRAM | CAD NO. EK228L01PD000A | SRT 003 |
| | | | | | | DRAWING NO. EK228L01PD/003 | |

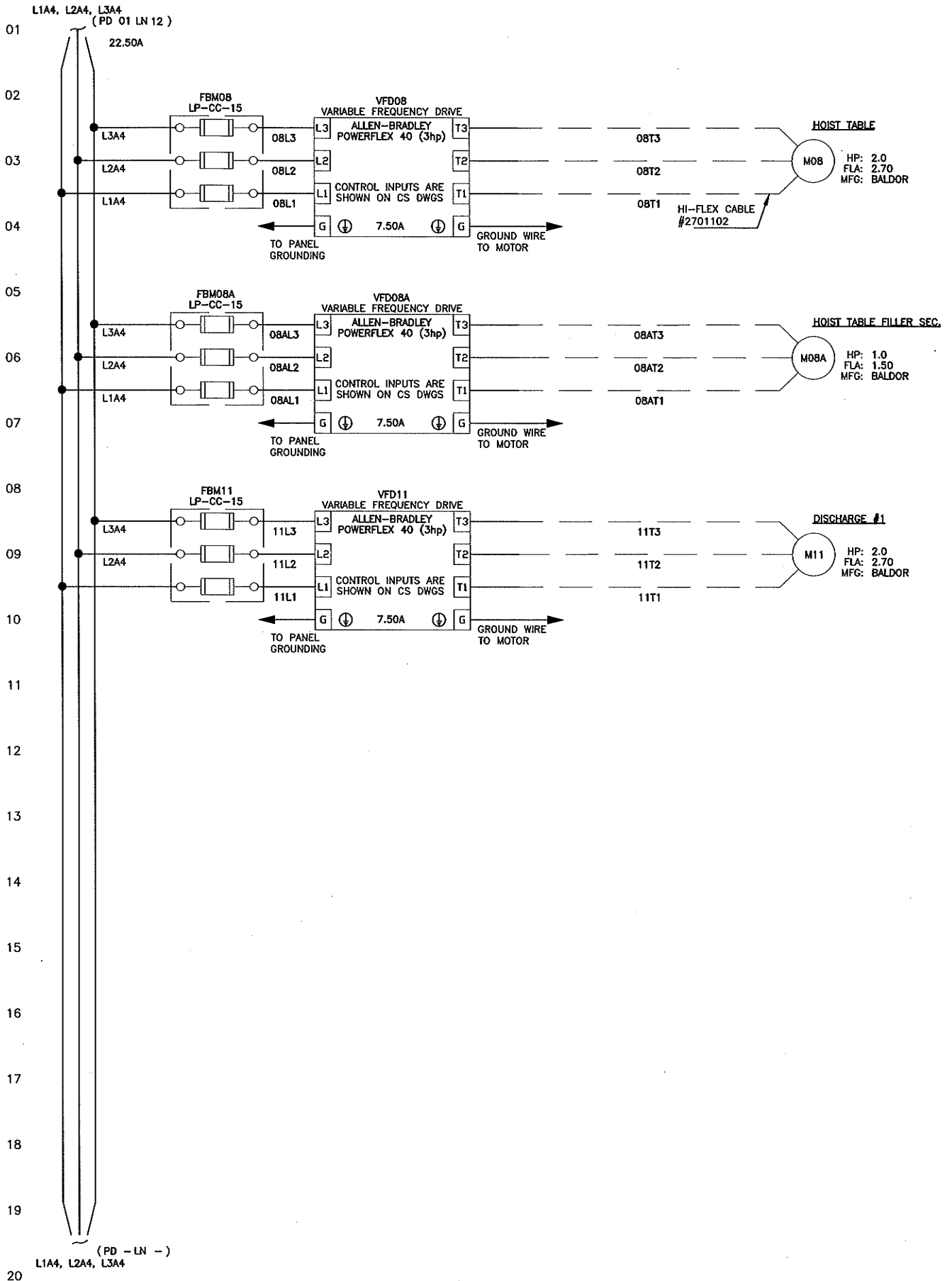

| | | | | | | | | | |
|-----|------|-------------|----|----------|---|-------------|----------------|------|---------|
| REV | DATE | DESCRIPTION | BY | CUSTOMER | DIAGEO NORTH AMERICA INC. RELAY, MD. | BY | HEDDERICH | DATE | 1/13/10 |
| | | | | TITLE | POWER DIAGRAM | CAD NO. | EK228L01PD000A | SHT | 004 |
| | | | | | | DRAWING NO. | EK228L01PD/004 | | |



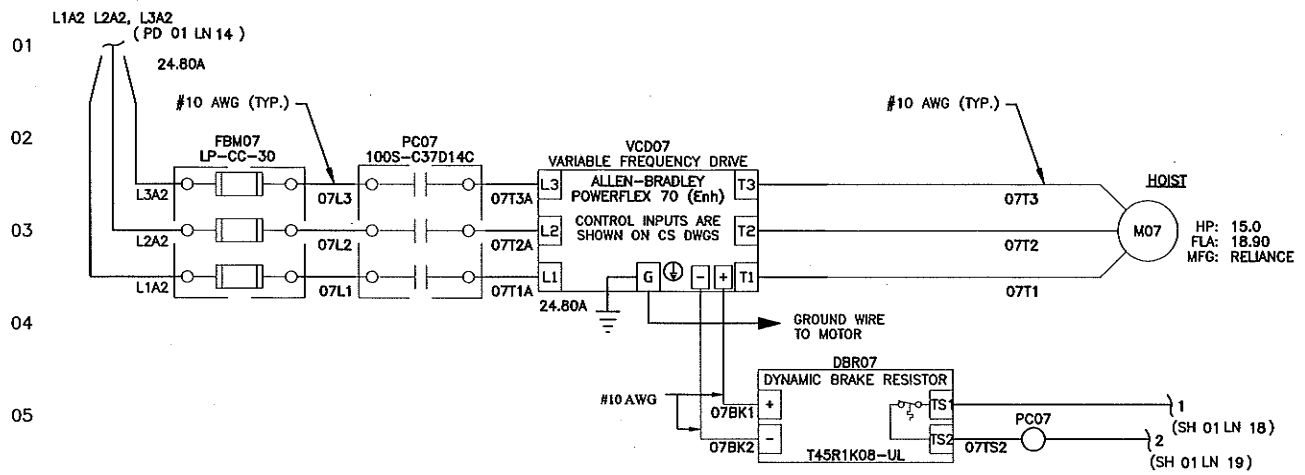

01
02
03
04
05
06
07
08
09
10
11
12
13
14
15
16
17
18
19
20

| | | | | | | | |
|-----|------|-------------|--|---|----------------------------|----------------------------------|--|
| | | | | CUSTOMER DIAGEO NORTH AMERICA INC. RELAY, MD. | | BY HEDDERICH DATE 1/13/10 | |
| | | | | TITLE POWER DIAGRAM | | CAD NO. EK228L01PD000A SHEET 005 | |
| REV | DATE | DESCRIPTION | | BY | DRAWING NO. EK228L01PD/005 | | |

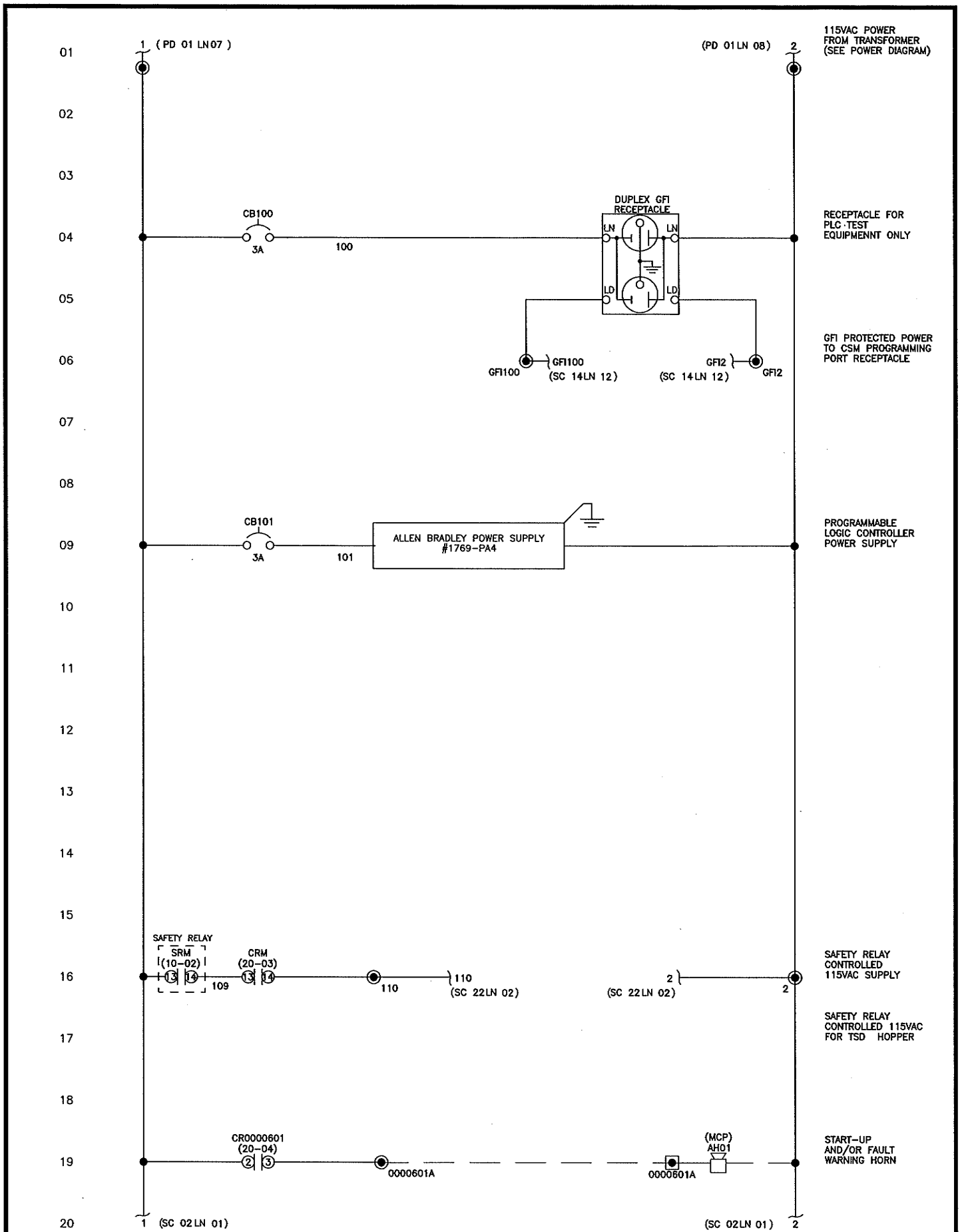

| | | | | | | | | | |
|-----|--|------|-------------|----|---|--|--|------------------------|--------------------------------------|
| REV | | DATE | DESCRIPTION | BY | | | CUSTOMER DIAGEO NORTH AMERICA INC. RELAY, MD. | BY HEDDERICH | DATE 1/13/10 |
| | | | | | TITLE CONTROL VOLTAGE SCHEMATIC | | CAD NO. EK228L01SC000A | SHEET 001 | DRAWING NO. EK228L01SC/001 |

01
02
03
04
05
06
07
08
09
10
11
12
13
14
15
16
17
18
19
20

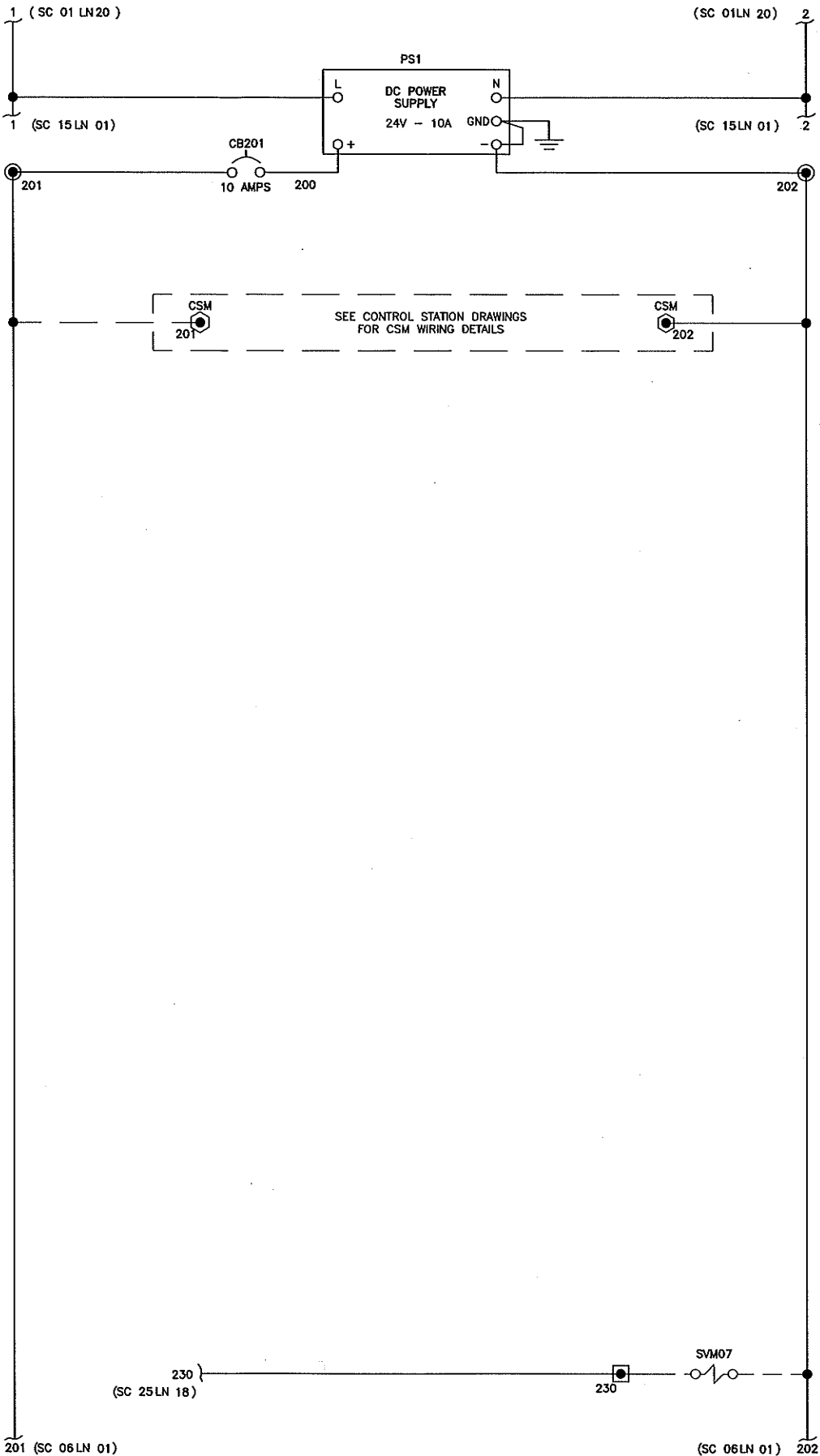

| | | | | | | | | | |
|-----|------|-------------|----|----------|---|-------------|----------------|------|---------|
| REV | DATE | DESCRIPTION | BY | CUSTOMER | DIAGEO NORTH AMERICA INC. RELAY, MD. | BY | HEDDERICH | DATE | 1/13/10 |
| | | | | TITLE | CONTROL VOLTAGE SCHEMATIC | CAD NO. | EK228L01SC000A | SHT | 002 |
| | | | | | | DRAWING NO. | EK228L01SC/002 | | |



01
02
03
04
05
06
07
08
09
10
11
12
13
14
15
16
17
18
19
20

SPARE SHEET FOR ADDITIONAL COMPONENTS

| | | | | | | | | |
|-----|------|-------------|--|---|---|---------------------------|-----------------|-------------------------------|
| | | | |  | CUSTOMER DIAGEO NORTH AMERICA INC. RELAY, MD. | | BY HEDDERICH | DATE 1/13/10 |
| | | | | | TITLE CONTROL VOLTAGE SCHEMATIC | CAD NO. EK228L01SC000A | SHEET 003 | DRAWING NO. EK228L01SC/003 |
| REV | DATE | DESCRIPTION | | BY | | | | |

01
02
03
04
05
06
07
08
09
10
11
12
13
14
15
16
17
18
19
20

1 (SC 02 LN02)

SPARE SHEET FOR ADDITIONAL COMPONENTS

(SC 02LN 02) 2

| | | | | | | | | | | | |
|-----|------|-------------|----|---|----------|---|-------------|----------------|---------|----------------|-----|
| REV | DATE | DESCRIPTION | BY |  | CUSTOMER | DIAGEO NORTH AMERICA INC. RELAY, MD. | BY | HEDDERICH | DATE | 1/13/10 | |
| | | | | | TITLE | CONTROL VOLUME SCHEMATIC | DRAWING NO. | EK228L01SC/004 | DWG NO. | EK228L01SC000A | SHT |

01
02
03
04
05
06
07
08
09
10
11
12
13
14
15
16
17
18
19
20

| | | | | | | | | | | | |
|-----|------|-------------|----|---|----------|---|-------------|----------------|--------|----------------|-----|
| REV | DATE | DESCRIPTION | BY |  FKI Logistex | CUSTOMER | DIAGEO NORTH AMERICA INC. RELAY, MD. | BY | HEDDERICH | DATE | 1/13/10 | |
| | | | | | TITLE | CONTROL VOLTAGE SCHEMATIC | DRAWING NO. | EK228L01SC/005 | EAD NO | EK228L01SC000A | SHT |

01
02
03
04
05
06
07
08
09
10
11
12
13
14
15
16
17
18
19
20

201 (SC 02 LN20)

(SC 02LN 20) 202

Note: SEE CONNECTION DIAGRAM DRAWINGS FOR CHART DETAILING FUNCTION OF ALL TERMINALS

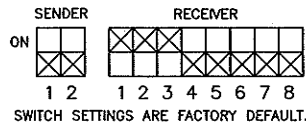
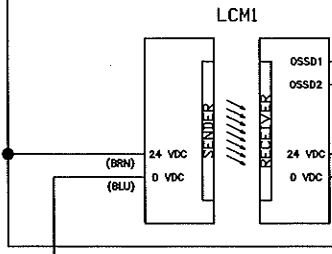

MSR127TP
440R-N23132

SRLCM1
A1 4 A2

RESET

S34

S11

S12

K1

S52

S21

K2

S22

TOP PERIMETER
LIGHT CURTAIN LCM1
& SAFETY RELAY

LCM1
LIGHT CURTAIN 1
CHANNEL "A"

LCM1
LIGHT CURTAIN 1
CHANNEL "B"

Note: SEE CONNECTION DIAGRAM DRAWINGS FOR CHART DETAILING FUNCTION OF ALL TERMINALS

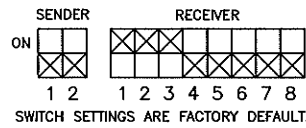
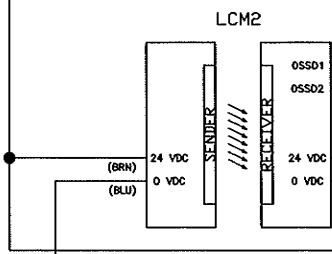

MSR127TP
440R-N23132

SRLCM2
A1 4 A2

RESET

S34

S11

S12

K1

S52

S21

K2

S22

TOP PERIMETER
LIGHT CURTAIN LCM2
& SAFETY RELAY

LCM1
LIGHT CURTAIN 2
CHANNEL "A"

LCM1
LIGHT CURTAIN 2
CHANNEL "B"

Note: SEE CONNECTION DIAGRAM DRAWINGS FOR CHART DETAILING FUNCTION OF ALL TERMINALS

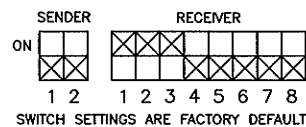
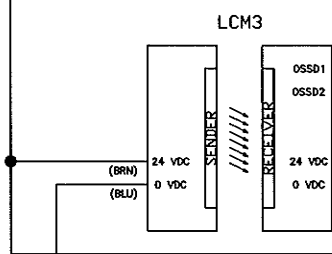

MSR127TP
440R-N23132

SRLCM3
A1 4 A2

RESET

S34

S11

S12

K1

S52

S21

K2

S22

TOP PERIMETER
LIGHT CURTAIN LCM3
& SAFETY RELAY

LCM1
LIGHT CURTAIN 3
CHANNEL "A"

LCM1
LIGHT CURTAIN 3
CHANNEL "B"

201 (SC 07 LN 01)

(SC 07LN 01) 202

| | | | | | | | | | | | |
|-----|--|--|------|--|---|-------------|---------------------------|--|-------------------------------|--|--|
| | | | | | CUSTOMER DIAGEO NORTH AMERICA INC. RELAY, MD. | | BY HEDDERICH | | DATE 1/13/10 | | |
| | | | | | TITLE CONTROL VOLTAGE SCHEMATIC | | CAD NO. EK228L01SC000A | | SHEET 006 | | |
| REV | | | DATE | | | DESCRIPTION | | | DRAWING NO. EK228L01SC/006 | | |

01
02
03
04
05
06
07
08
09
10
11
12
13
14
15
16
17
18
19
20

201 (SC 06 LN 20)

(SC 06LN 20) 202

Note: SEE CONNECTION DIAGRAM DRAWINGS FOR CHART DETAILING FUNCTION OF ALL TERMINALS

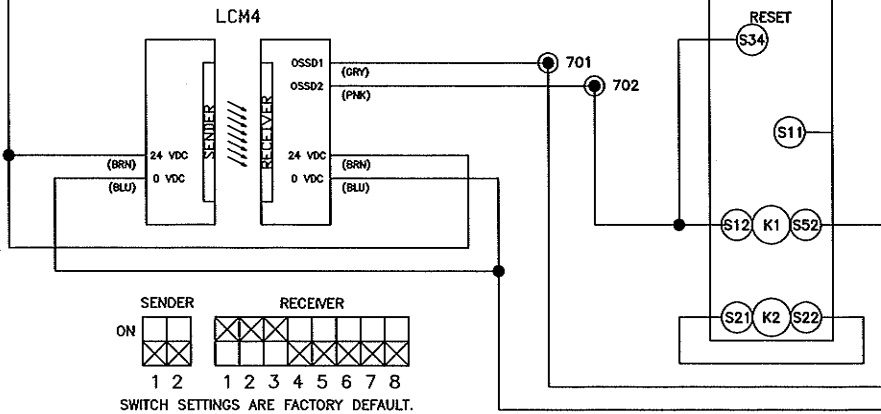

TOP PERIMETER LIGHT CURTAIN LCM4 & SAFETY RELAY

LCM1 LIGHT CURTAIN 4 CHANNEL "A"

LCM1 LIGHT CURTAIN 4 CHANNEL "B"

201 (SC 08 LN 01)

(SC 08LN 01) 202

| | | | | | | | | | | | |
|-----|--|------|-------------|----|--|-------------|---|---------|----------------|------|---------|
| REV | | DATE | DESCRIPTION | BY | | CUSTOMER | DIAGEO NORTH AMERICA INC. RELAY, MD. | BY | HEDDERICH | DATE | 1/13/10 |
| | | | | | | TITLE | CONTROL VOLTAGE SCHEMATIC | CAD NO. | EK228L01SC000A | SHT | 007 |
| | | | | | | DRAWING NO. | EK228L01SC/007 | | | | |

01
02
03
04
05
06
07
08
09
10
11
12
13
14
15
16
17
18
19
20

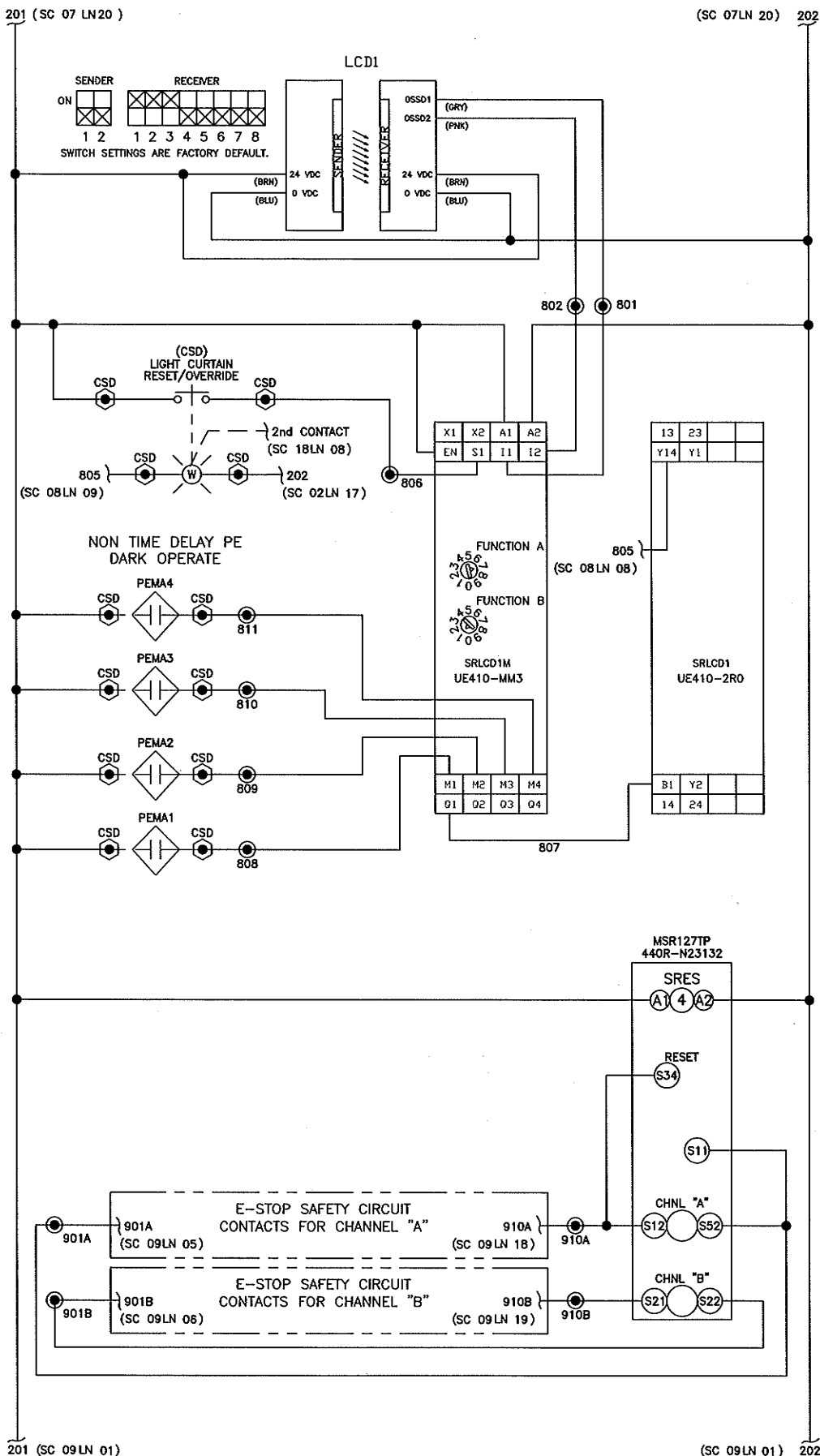

DISCHARGE LIGHT CURTAIN LCD1

DISCHARGE LIGHT CURTAIN AND MUTING SAFETY RELAYS

| SW # | SETTING |
|------|---------|
| SW A | 7 |
| SW B | 1 |

EMERGENCY STOP SAFETY RELAY WITH AUTO RESET

NOTE:
SEE CONNECTION DIAGRAM DRAWING SET FOR THE CHART DETAILING FUNCTION OF ALL TERMINALS.

EMERGENCY STOP SWITCH CONTACTS LOOP CHANNEL A

EMERGENCY STOP SWITCH CONTACTS LOOP CHANNEL B

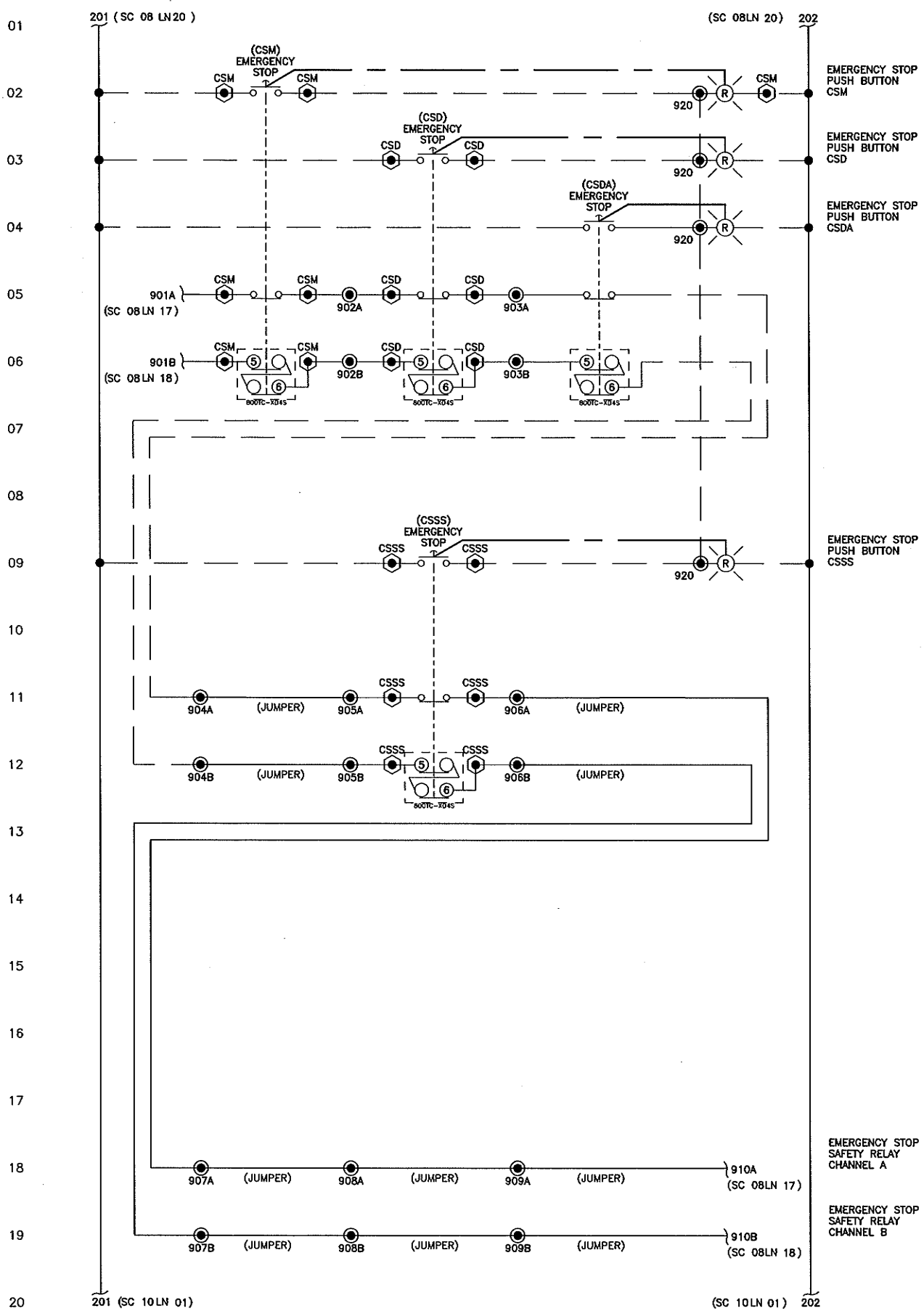

| | | | | | | | | | |
|-----|------|-------------|----|----------|---|----|-----------|-------------|----------------|
| REV | DATE | DESCRIPTION | BY | CUSTOMER | DIAGEO NORTH AMERICA INC. RELAY, MD. | BY | HEDDERICH | DATE | 1/13/10 |
| | | | | | | | | CAD NO | EK228L01SC000A |
| | | | | | | | | SHT | 009 |
| | | | | TITLE | CONTROL VOLTAGE SCHEMATIC | | | DRAWING NO. | EK228L01SC/009 |

01
02
03
04
05
06
07
08
09
10
11
12
13
14
15
16
17
18
19
20

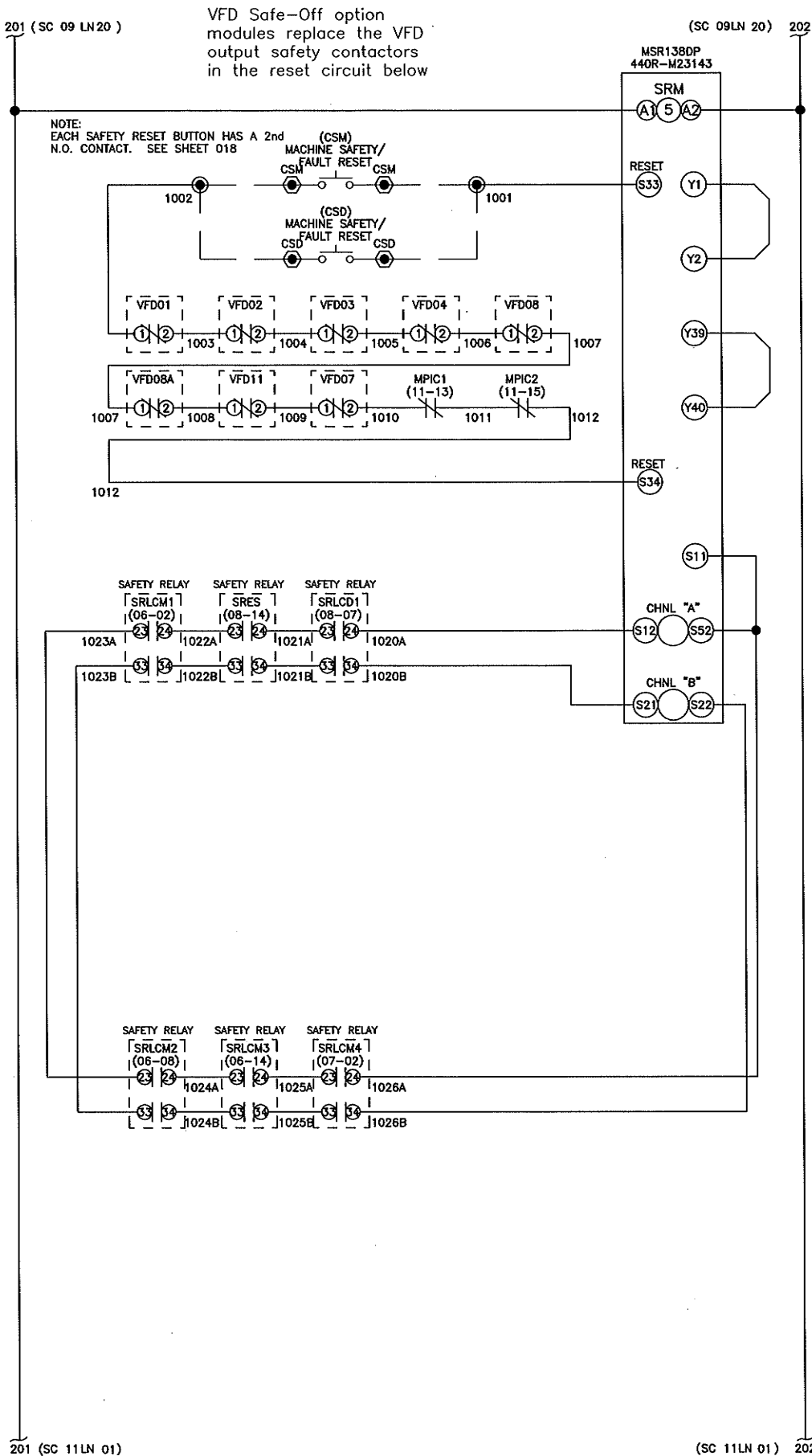

MAIN
SAFETY
RELAY

CSM
MACHINE SAFETY/
FAULT RESET

CSD
MACHINE SAFETY/
FAULT RESET

MAIN SAFETY RELAY
CHANNEL "A" AND "B"
INPUT CONTROL LOOP

| | | | | | | | | | |
|-----|------|-------------|----|----------|---|----|-----------|-------------|----------------|
| REV | DATE | DESCRIPTION | BY | CUSTOMER | DIAGEO NORTH AMERICA INC. RELAY, MD. | BY | HEDDERICH | DATE | 1/13/10 |
| | | | | TITLE | CONTROL VOLTAGE SCHEMATIC | | | CAD NO. | EK228L01SC000A |
| | | | | | | | | SHF | 010 |
| | | | | | | | | DRAWING NO. | EK228L01SC/010 |



01
02
03
04
05
06
07
08
09
10
11
12
13
14
15
16
17
18
19
20

201 (SC 10 LN 20)

(SC 10LN 20) 202

SAFETY RELAY
SRM
(10-02)

1000200

1000200
(SC 16LN 03)

MACHINE
SAFETY RELAY
IS ENABLED

CSM MACHINE SAFETY/
FAULT RESET PB
PILOT LIGHT

CSD MACHINE SAFETY/
FAULT RESET PB
PILOT LIGHT

MOTOR POWER
ISOLATION
CONTACTOR 1

ROSS SAFETY AIR
DUMP VALVE
SOLENOID "A"

MOTOR POWER
ISOLATION
CONTACTOR 2

ROSS SAFETY AIR
DUMP VALVE
SOLENOID "B"

CRM
(20-03)

1000201

1000201
(SC 16LN 04)

MACHINE
STARTED
INPUT

CSM START
PUSH BUTTON
PILOT LIGHT

CSD START
PUSH BUTTON
PILOT LIGHT

SAFETY RELAY
CONTROLLED
24VDC POWER

SAFETY RELAY
CONTROLLED
24VDC POWER

201 (SC 12LN 01)

(SC 12LN 01) 202

| | | | | | | | |
|-----|------|---|----|--|--|--------------------------------|--|
| | |  | | CUSTOMER DIAGEO NORTH AMERICA INC. RELAY, MD. | | BY HEDDERICH DATE 1/13/10 | |
| | | | | TITLE CONTROL VOLTAGE SCHEMATIC | | DAD NO. EK228L01SC000A SH# 011 | |
| REV | DATE | DESCRIPTION | BY | DRAWING NO. EK228L01SC/011 | | | |

01
02
03
04
05
06
07
08
09
10
11
12
13
14
15
16
17
18
19
20

201 (SC 11 LN 20)

(SC 11LN 20) 202

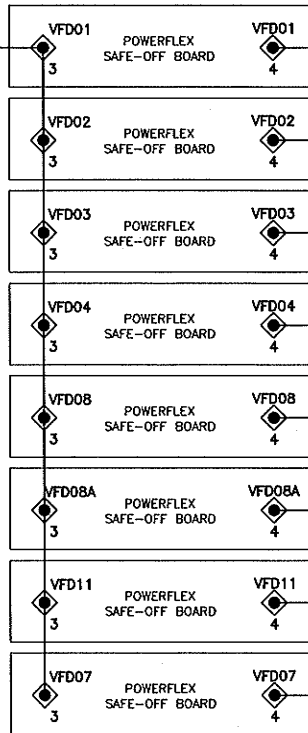
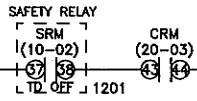

SAFE-OFF BOARD FOR VFD01

SAFE-OFF BOARD FOR VFD02

SAFE-OFF BOARD FOR VFD03

SAFE-OFF BOARD FOR VFD04

SAFE-OFF BOARD FOR VFD08

SAFE-OFF BOARD FOR VFD08A

SAFE-OFF BOARD FOR VFD11

SAFE-OFF BOARD FOR VFD07

201 (SC 14LN 01)

(SC 14LN 01) 202

| | | | | | | | | | |
|-----|------|-------------|----|----------|---|----|-----------|-------------|----------------|
| REV | DATE | DESCRIPTION | BY | CUSTOMER | DIAGEO NORTH AMERICA INC. RELAY, MD. | BY | HEDDERICH | DATE | 1/13/10 |
| | | | | | | | | CAD NO. | EK228L01SC000A |
| | | | | | | | | SHIT | 012 |
| | | | | TITLE | CONTROL VOLTAGE SCHEMATIC | | | DRAWING NO. | EK228L01SC/012 |



01
02
03
04
05
06
07
08
09
10
11
12
13
14
15
16
17
18
19
20

SYSTEM INTERLOCKS TO OTHERS

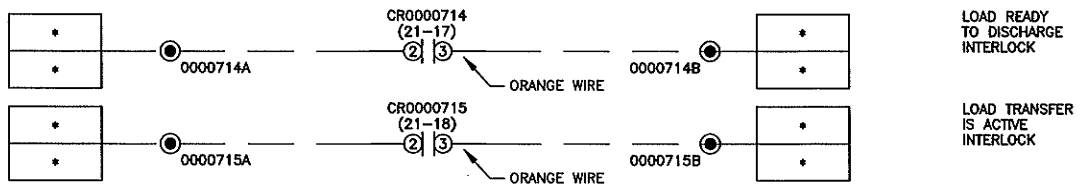

SYSTEM INTERLOCKS FROM OTHERS

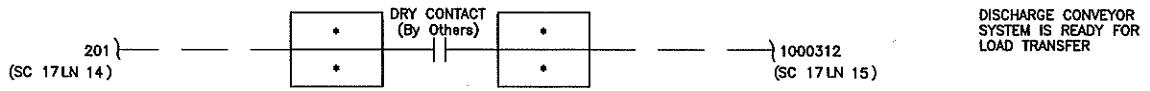

| | | | | | | | | | | | |
|-----|------|-------------|----|--|----------|---|-------------|----------------|----------|----------------|-----|
| REV | DATE | DESCRIPTION | BY | | CUSTOMER | DIAGEO NORTH AMERICA INC. RELAY, MD. | BY | HEDDERICH | DATE | 1/13/10 | |
| | | | | | TITLE | CONTROL VOLTAGE SCHEMATIC | DRAWING NO. | EK228L01SC/013 | EXP. NO. | EK228L01SC000A | SHT |

01
02
03
04
05
06
07
08
09
10
11
12
13
14
15
16
17
18
19
20

201 (SC 12 LN 20)

(SC 12LN 20) 202

201 (SC 16 LN 01)

(SC 16LN 01) 202

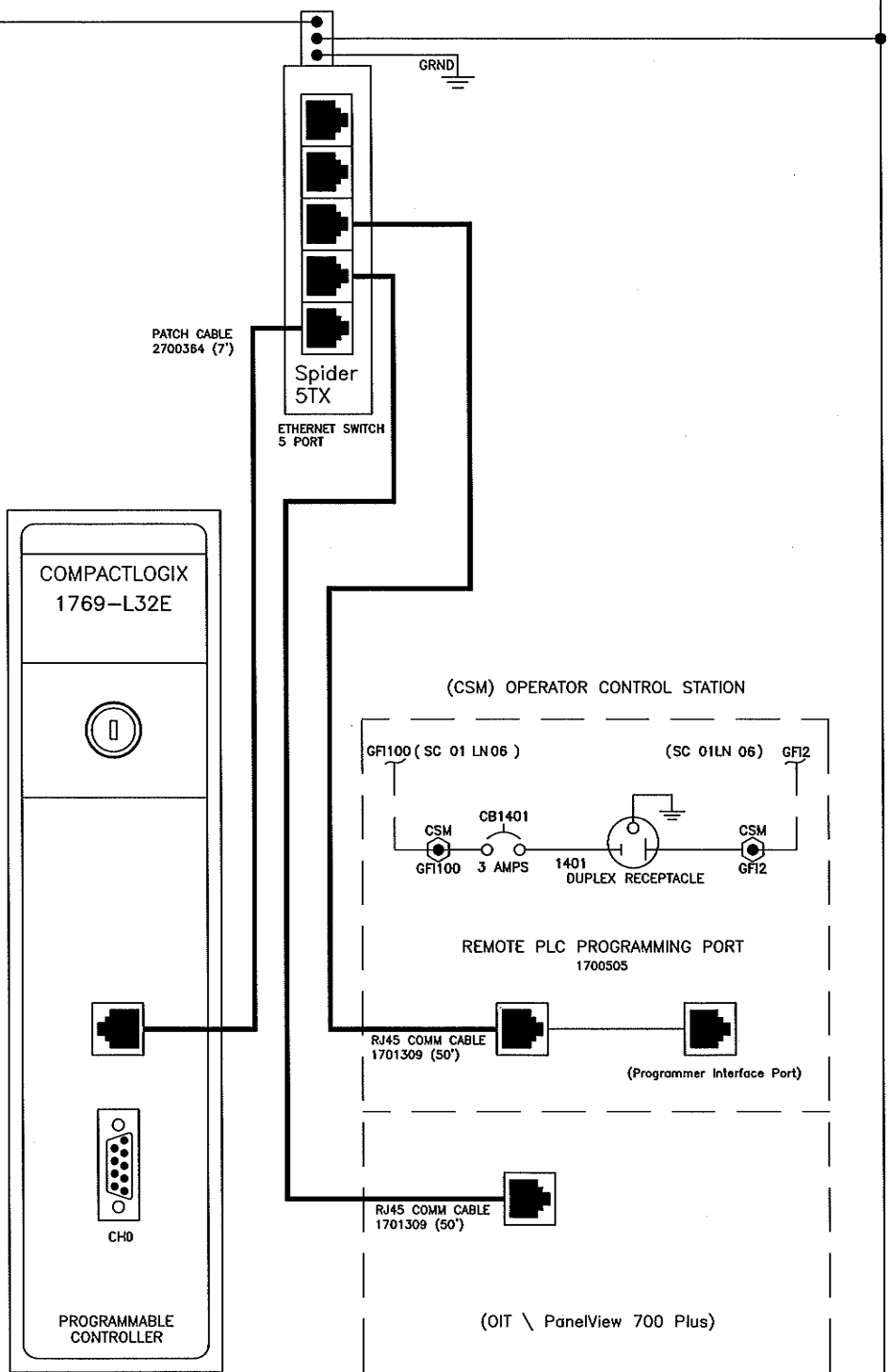

POWER FOR PROGRAMMING RECEPTACLE

REMOTE PLC PROGRAMMING PORT

ETHERNET TERMINATION AT CSM

| | | | | | | | | | | | |
|-----|--|------|-------------|----|--|----------|---|-------------|----------------|------|---------|
| REV | | DATE | DESCRIPTION | BY | | CUSTOMER | DIAGEO NORTH AMERICA INC. RELAY, MD. | BY | HEDDERICH | DATE | 1/13/10 |
| | | | | | | TITLE | CONTROL VOLTAGE SCHEMATIC | DRAWING NO. | EK228L01SC/014 | SHT | 014 |

01
02
03
04
05
06
07
08
09
10
11
12
13
14
15
16
17
18
19
20

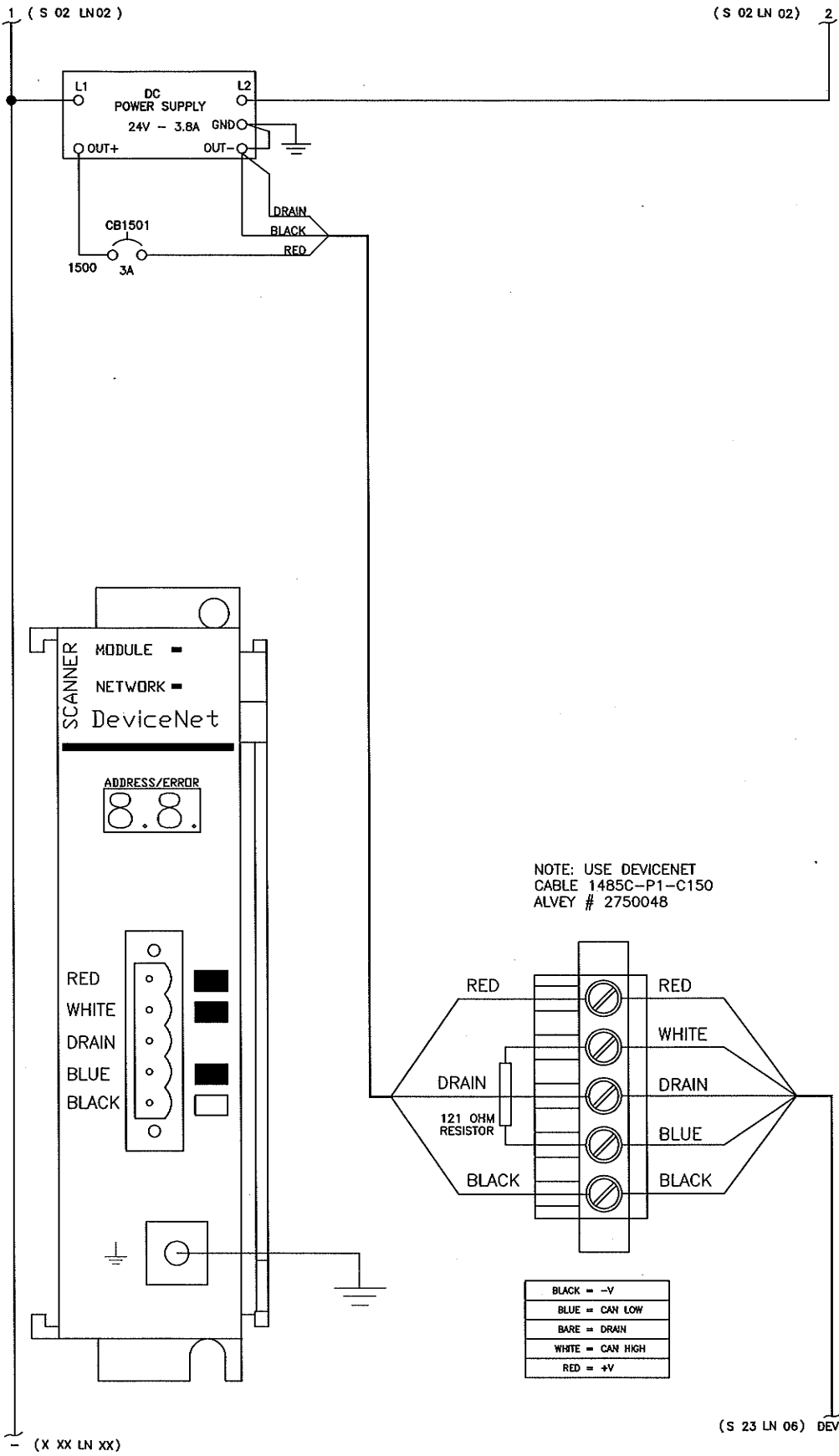

24VDC POWER SUPPLY #2 FOR DEVICENET

NOTE: USE DEVICENET CABLE 1485C-P1-C150 ALVEY # 2750048

TO POINT I/O MODULES

| |
|------------------|
| BLACK = -V |
| BLUE = CAN LOW |
| BARE = DRAIN |
| WHITE = CAN HIGH |
| RED = +V |

| | | | | | | | | | | |
|-----|------|-------------|----|--|-------------|---|---------|----------------|------|---------|
| REV | DATE | DESCRIPTION | BY | | CUSTOMER | DIAGEO NORTH AMERICA INC. RELAY, MD. | BY | HEDDERICH | DATE | 1/13/10 |
| | | | | | TITLE | CONTROL VOLTAGE SCHEMATIC | CAD NO. | EK228L01SC000A | SHT | 015 |
| | | | | | DRAWING NO. | EK228L01SC/015 | | | | |

01
02
03
04
05
06
07
08
09
10
11
12
13
14
15
16
17
18
19
20

201 (SC 15 LN 20)

(SC 15LN 20) 202

MODULE TAG NAME
Local:2:1.xx

1769-IQ16
24V DC INPUT

1000200 }
(SC 11LN 02)

1000201 }
(SC 11LN 13)

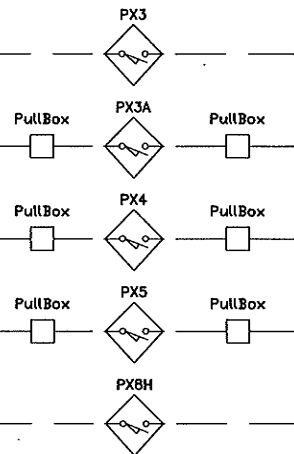

1000200
1000201
1000202
1000203
1000204
1000205
1000206
1000207
1000208
1000209
1000210
1000211
1000212
1000213
1000214
1000215

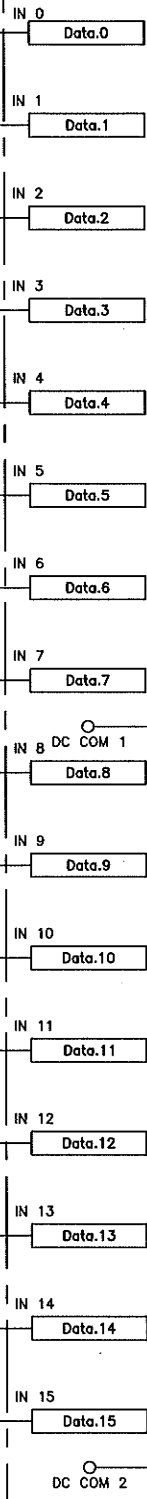

MACHINE SAFETY RELAY IS ENABLED
MACHINE STARTED INPUT
E-STOP RELAY SRES IS NOT ENABLED
SPARE
ROW PUSHER HOME
PUSHER BAR AT FULL LAYER SIZE
APRON IS OPEN
APRON IS CLOSED
POWERED HOIST TABLE IS DOWN
SPARE
SPARE
SPARE
HOIST CHAIN SLACK MONITOR (Left side)
HOIST CHAIN SLACK MONITOR (Right side)
HOIST BLOCK IS STOWED (Left Side)
HOIST BLOCK IS STOWED (Right Side)

THIS MODULE OCCUPIES RACK # 00/ SLOT # 02

201 (SC 17 LN 01)

(SC 17LN 01) 202

| | | | | | | | | | | | |
|-----|--|------|-------------|----|--|----------|---|----------------|----------------|------|---------|
| REV | | DATE | DESCRIPTION | BY | | CUSTOMER | DIAGEO NORTH AMERICA INC. RELAY, MD. | BY | HEDDERICH | DATE | 1/13/10 |
| | | | | | | TITLE | CONTROL VOLTAGE SCHEMATIC | CAD NO. | EK228L01SC000A | SHT | 016 |
| | | | | | | | DRAWING NO. | EK228L01SC/016 | | | |

01
02
03
04
05
06
07
08
09
10
11
12
13
14
15
16
17
18
19
20

201 (SC 16 LN20)

(SC 16LN 20)

202

MODULE TAG NAME
Local:3:I.xx

1769-IQ16
24V DC INPUT

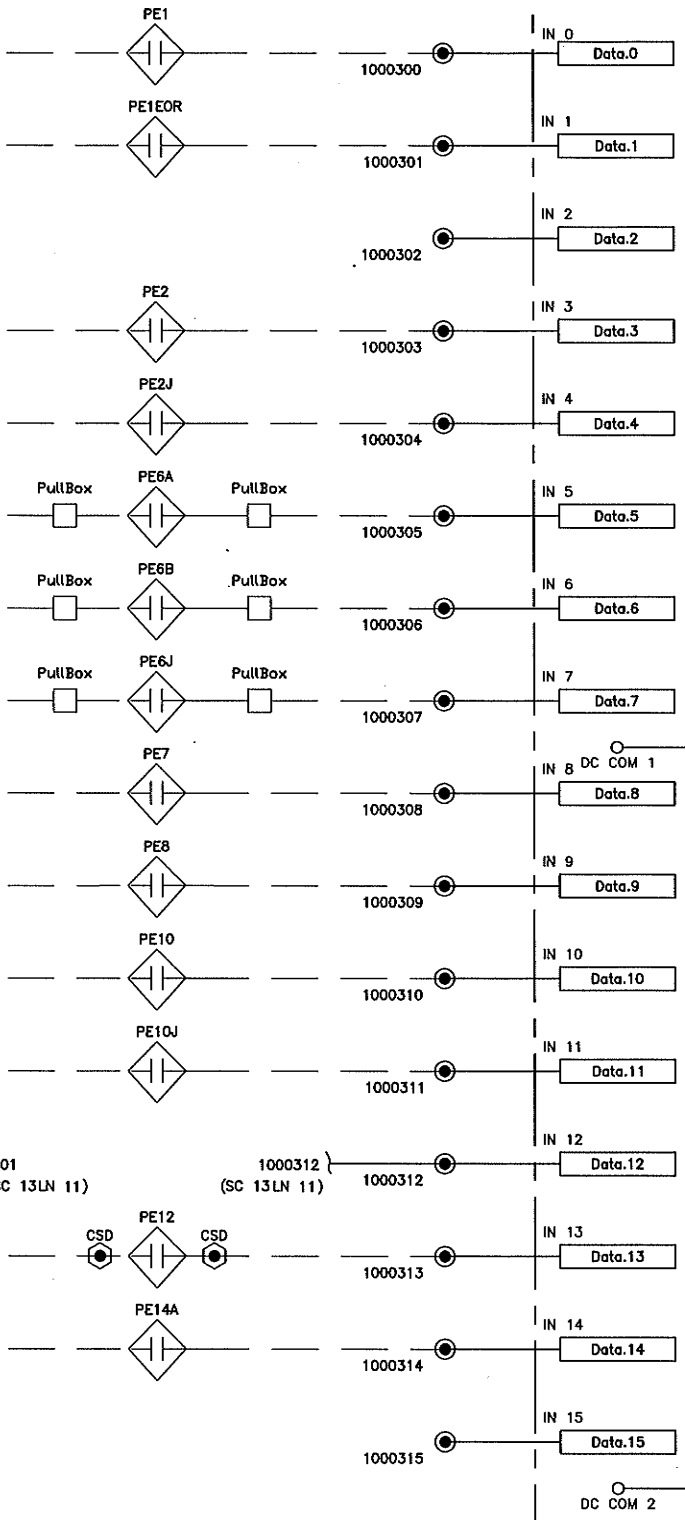

CASE
COUNT
EYE

END OF
RUN CASE
DETECT

SPARE

ROW PUSHER
IS CLEAR
TO PUSH

INFED TO
ROW FORMER
JAM EYE

AREA UNDER
APRON IS CLEAR
(LEFT SIDE)

AREA UNDER
APRON IS CLEAR
(RIGHT SIDE)

HOIST
UPPER
TRAVEL LIMIT

CLEAR TO
RAISE HOIST
IN HIGH SPEED

HOIST
IS
DOWN

HOIST
AREA
IS CLEAR

PALLET
OVERTRAVEL
DETECTION

DISCHARGE CONVEYOR
SYSTEM IS READY FOR
LOAD TRANSFER

LOAD DISCHARGE
DETECTION
PHOTOEYE

REAR OF
HOIST
IS CLEAR

THIS MODULE OCCUPIES
RACK # 00/ SLOT # 03

201 (SC 18 LN 01)

(SC 18LN 01)

202

| | | | | | | | | |
|-------------------------|--|--|--|--|--|--|---|--|
| | | | | | CUSTOMER DIAGEO NORTH AMERICA INC. RELAY, MD. | | BY HEDDERICH DATE 1/13/10 | |
| | | | | | TITLE CONTROL VOLTAGE SCHEMATIC | | CAD NO EK228L01SC000A SHT 017 | |
| REV DATE DESCRIPTION BY | | | | | DRAWING NO. EK228L01SC/017 | | | |

01
02
03
04
05
06
07
08
09
10
11
12
13
14
15
16
17
18
19
20

201 (SC 17 LN 20)

(SC 17LN 20)

202

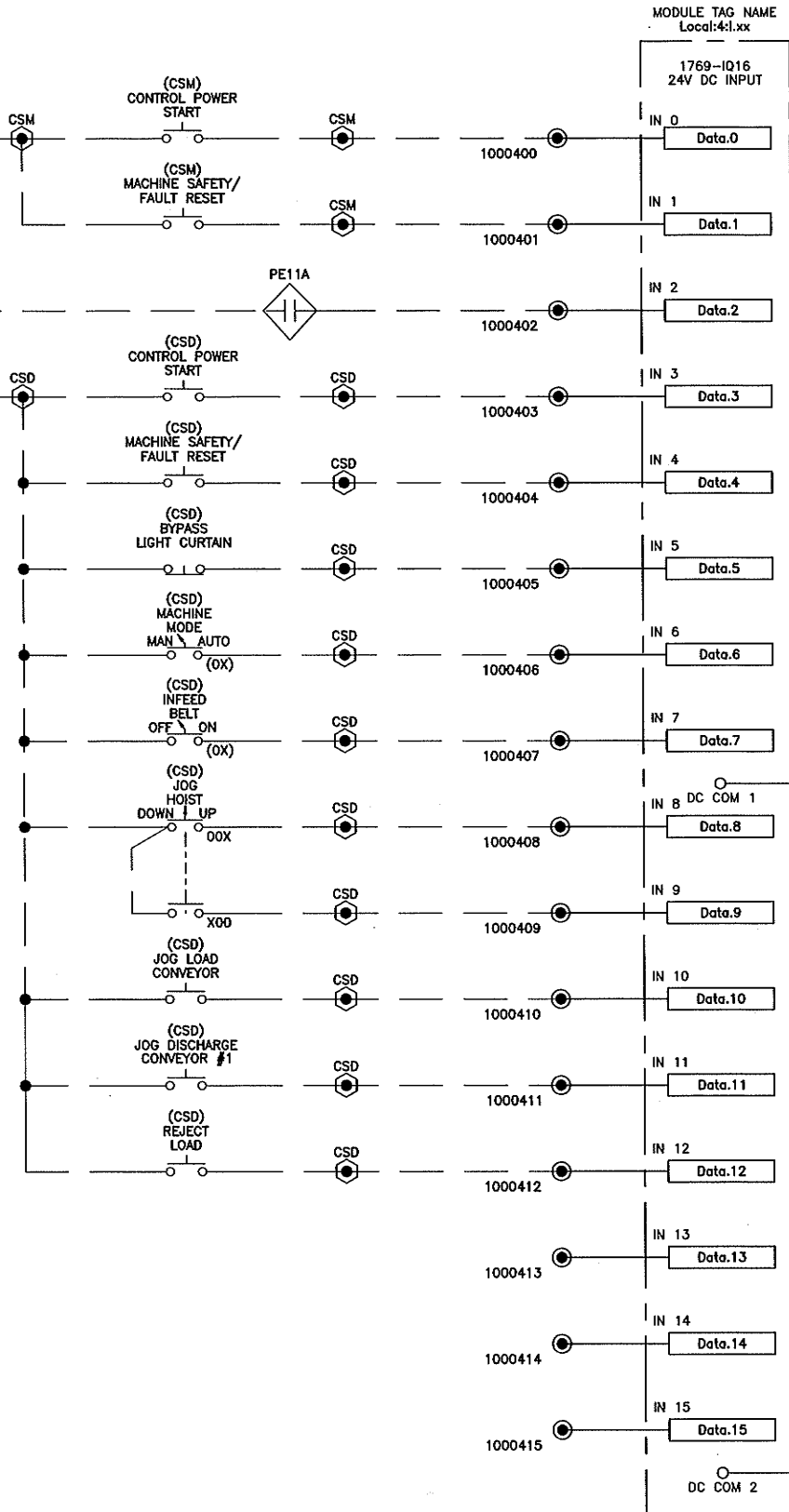

MACHINE CONTROL
POWER "START"
PUSHBUTTON

MACHINE SAFETY/
FAULT RESET
PUSHBUTTON

DISCHARGE
CONVEYOR #1
IS CLEAR

MACHINE CONTROL
POWER "START"
PUSHBUTTON

MACHINE SAFETY/
FAULT RESET
PUSHBUTTON

BYPASS
LIGHT CURTAIN
PUSHBUTTON

MACHINE MODE
SWITCH IN
"AUTO"

INFEEED BELT
SWITCH IN
"ON"

MANUAL CONTROL
SWITCH IN JOG
"HOIST UP"

MANUAL CONTROL
SWITCH IN JOG
"HOIST DOWN"

JOG LOAD
CONVEYOR
PUSHBUTTON

JOG DISCHARGE
CONVEYOR #1

REJECT
LOAD

SPARE

SPARE

SPARE

201 (SC 19 LN 01)

(SC 19LN 01)

202

| | | | | | | | | | | |
|-----|--|------|-------------|----|-------------|---|---------|----------------|------|---------|
| REV | | DATE | DESCRIPTION | BY | CUSTOMER | DIAGEO NORTH AMERICA INC. RELAY, MD. | BY | HEDDERICH | DATE | 1/13/10 |
| | | | | | TITLE | CONTROL VOLTAGE SCHEMATIC | CAD NO. | EK228L01SC000A | SHT | 018 |
| | | | | | DRAWING NO. | EK228L01SC/018 | | | | |

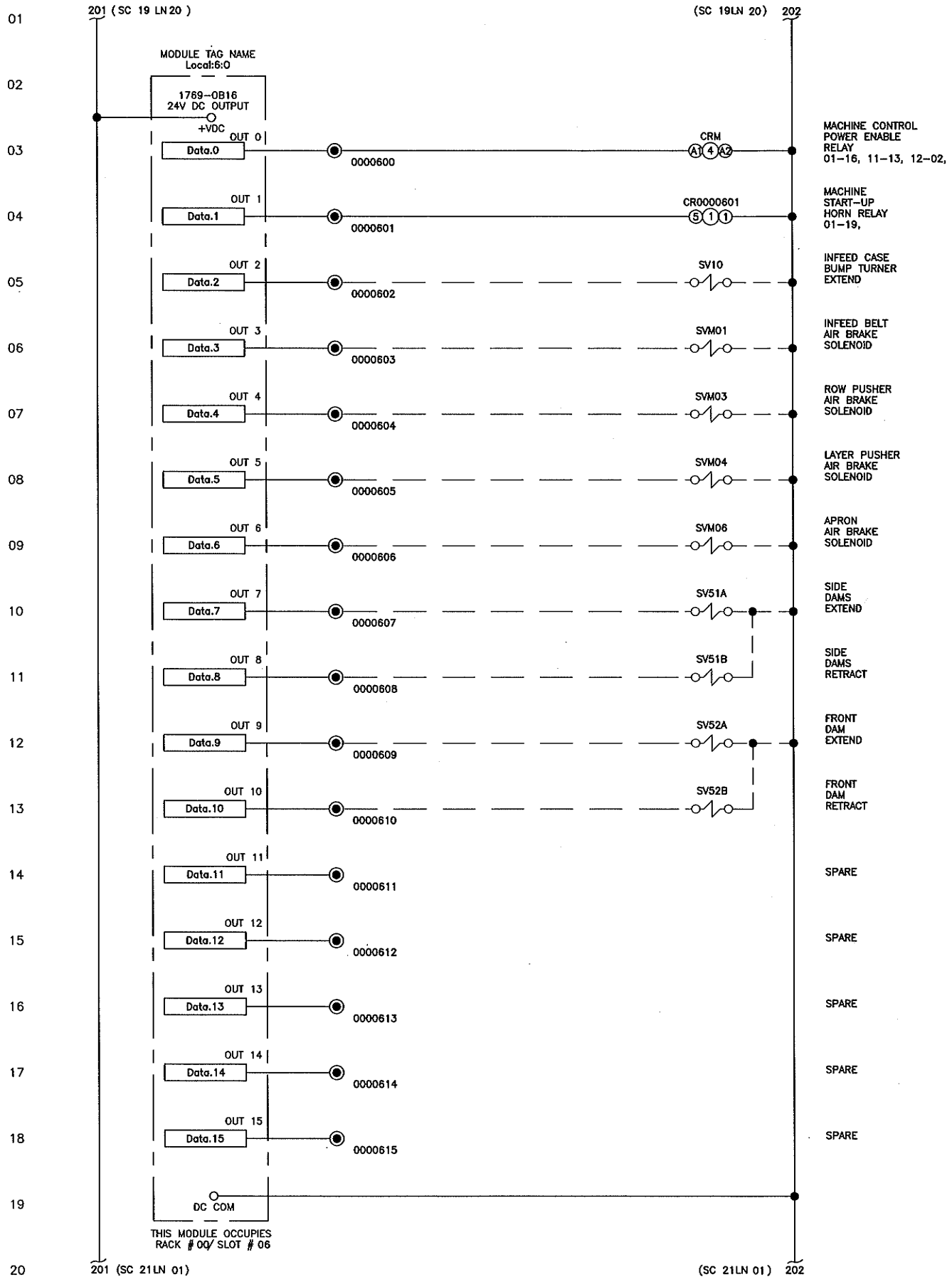

| | | | | | | | | | |
|-----|------|-------------|----|--|--|---|----------------------------------|-------------|-----------------------|
| REV | DATE | DESCRIPTION | BY | | CUSTOMER DIAGED NORTH AMERICA INC. RELAY, MD. | BY | HEDDERICH | DATE | 1/13/10 |
| | | | | | | TITLE | CONTROL VOLTAGE SCHEMATIC | DRAWING NO. | EK228L01SC/020 |
| | | | | | | THIS MODULE OCCUPIES RACK # 00/ SLOT # 06 | | | |

01
02
03
04
05
06
07
08
09
10
11
12
13
14
15
16
17
18
19
20

201 (SC 20 LN 20)

(SC 20LN 20) 202

MODULE TAG NAME
Local:7:0

1769-0B16
24V DC OUTPUT

+VDC

OUT 0

Data.0

OUT 1

Data.1

OUT 2

Data.2

OUT 3

Data.3

OUT 4

Data.4

OUT 5

Data.5

OUT 6

Data.6

OUT 7

Data.7

OUT 8

Data.8

OUT 9

Data.9

OUT 10

Data.10

OUT 11

Data.11

OUT 12

Data.12

OUT 13

Data.13

OUT 14

Data.14

OUT 15

Data.15

DC COM

THIS MODULE OCCUPIES
RACK # 00/ SLOT # 07

0000700

0000701

0000702

0000703

0000704

0000705

0000706

0000707

0000708

0000709

0000710

0000711

0000712

0000713

0000714

0000715

0000700
(SC 02LN 19)

SV24

SV25

SV27

SV30

SV31

SV32

SV33

SV37

CSSS

SV90

CSSS

CSSS

SV91

CSSS

CSSS

SV92A

CSSS

CSSS

SV92B

CSSS

SV93

CR0000714

(S) (I) (1)

CR0000715

(S) (I) (1)

HOIST FAIL SAFE
BRAKE CONTROL
OUTPUT

RAISE
PACKAGE
STOP #4

RAISE
PACKAGE
STOP #5

RAISE
PACKAGE
STOP #7

RAISE
PACKAGE
STOP #10

RAISE
PACKAGE
STOP #11

RAISE
PACKAGE
STOP #12

RAISE
PACKAGE
STOP #13

RAISE
PACKAGE
STOP #17

SLIPSHEET DISPENSER
VACUUM
ON

SLIPSHEET DISPENSER
CROSSHEAD
LOWER

SLIPSHEET DISPENSER
CROSSHEAD
EXTEND

SLIPSHEET DISPENSER
CROSSHEAD
RETRACT

RAISE PALLET STOP
AT SLIPSHEET
DISPENSER

LOAD READY
TO DISCHARGE
INTERLOCK
13-06,

LOAD TRANSFER
IS ACTIVE
INTERFACE
13-07,

201 (SC 22LN 01)

(SC 22LN 01) 202

| | | | | | | | | | | | | |
|-----|--|------|-------------|----|---|----------|---|-------------|----------------|---------|----------------|-----|
| REV | | DATE | DESCRIPTION | BY |  | CUSTOMER | DIAGEO NORTH AMERICA INC. RELAY, MD. | BY | HEDDERICH | DATE | 1/13/10 | |
| | | | | | | TIME | CONTROL VOLTAGE SCHEMATIC | DRAWING NO. | EK228L01SC/021 | CAD NO. | EK228L01SC000A | SHT |

01
02
03
04
05
06
07
08
09
10
11
12
13
14
15
16
17
18
19
20

201 (SC 21 LN 20)

(SC 21LN 20) 202

MODULE TAG NAME
Local:8:0

1769-OB16
24V DC OUTPUT

+VDC

OUT 0

Data.0

OUT 1

Data.1

OUT 2

Data.2

OUT 3

Data.3

OUT 4

Data.4

OUT 5

Data.5

OUT 6

Data.6

OUT 7

Data.7

OUT 8

Data.8

OUT 9

Data.9

OUT 10

Data.10

OUT 11

Data.11

OUT 12

Data.12

OUT 13

Data.13

OUT 14

Data.14

OUT 15

Data.15

DC COM

THIS MODULE OCCUPIES
RACK # 00/ SLOT # 08

201 (SC 23 LN 01)

(SC 23LN 01) 202

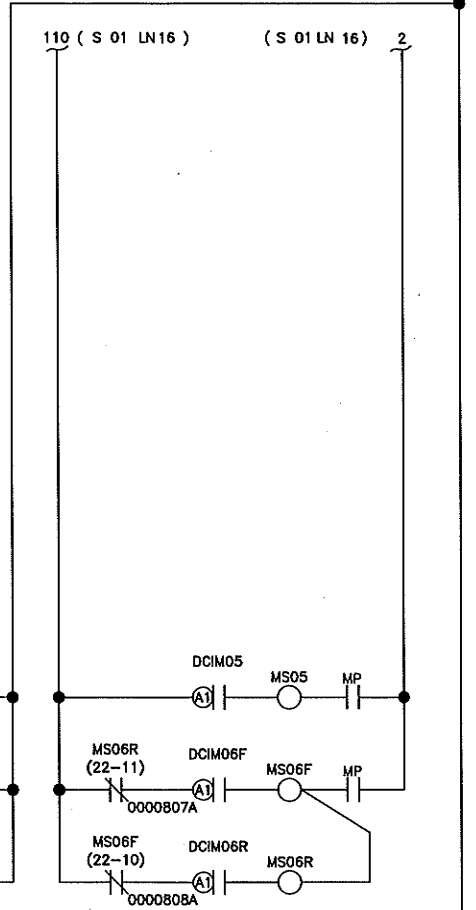

SPARE
SPARE
SPARE
SPARE
SPARE
SPARE
SPARE
SPARE
RUN LAYER TABLE
RUN APRON OPEN
RUN APRON CLOSE
SPARE
SPARE
SPARE
SPARE
SPARE
SPARE

| | | | | | | | | | |
|-----|------|-------------|----|----------|---|----|-----------|-------------|----------------|
| REV | DATE | DESCRIPTION | BY | CUSTOMER | DIAGEO NORTH AMERICA INC. RELAY, MD. | BY | HEDDERICH | DATE | 1/13/10 |
| | | | | TITLE | CONTROL VOLTAGE SCHEMATIC | | | CAD NO. | EK228L01SC000A |
| | | | | | | | | SHT | 022 |
| | | | | | | | | DRAWING NO. | EK228L01SC/022 |



01
02
03
04
05
06
07
08
09
10
11
12
13
14
15
16
17
18
19
20

201 (SC 22 LN 20)

(SC 22LN 20) 202

MODULE TAG NAME
Local:9:0

1769-OB16
24V DC OUTPUT

+VDC

OUT 0
Data.0

OUT 1
Data.1

OUT 2
Data.2

OUT 3
Data.3

OUT 4
Data.4

OUT 5
Data.5

OUT 6
Data.6

OUT 7
Data.7

OUT 8
Data.8

OUT 9
Data.9

OUT 10
Data.10

OUT 11
Data.11

OUT 12
Data.12

OUT 13
Data.13

OUT 14
Data.14

OUT 15
Data.15

DC COM

THIS MODULE OCCUPIES
RACK # 00/ SLOT # 09

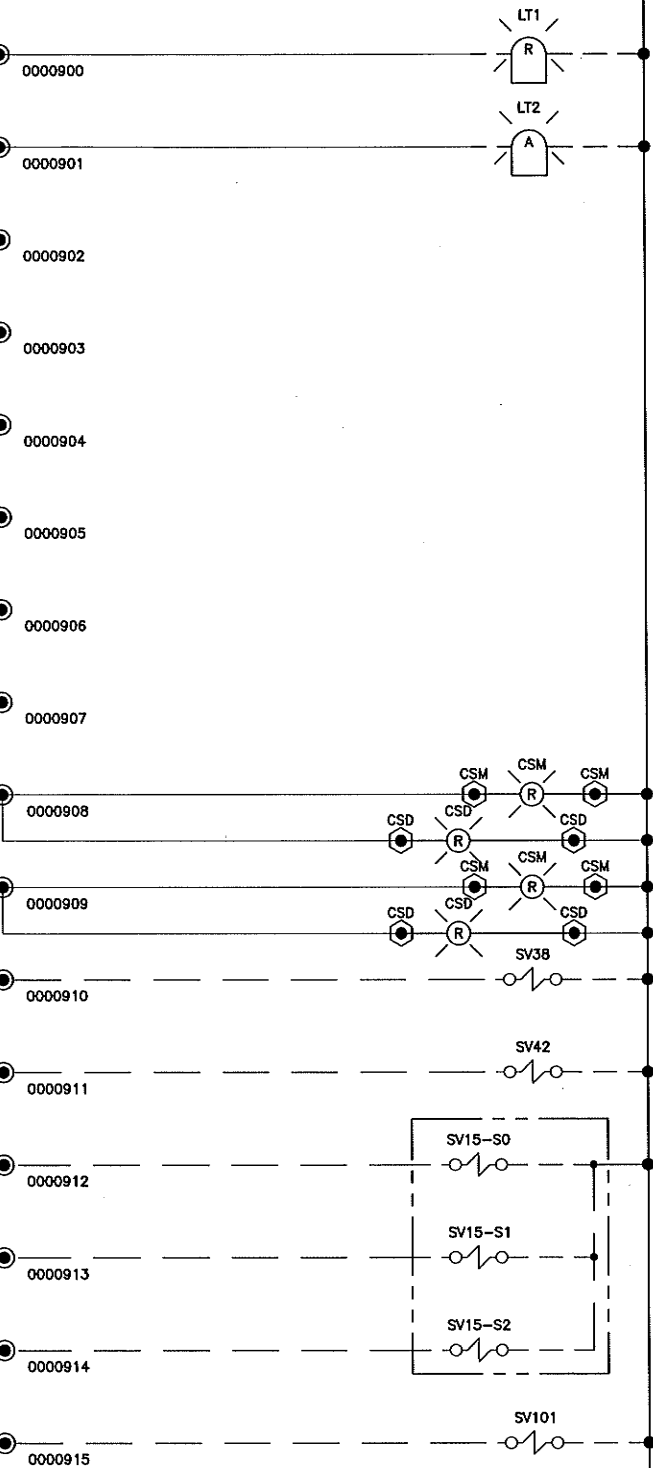

DIAGNOSTIC
WARNING
INDICATOR

LOW
SHEET
INDICATOR

SPARE

SPARE

SPARE

SPARE

SPARE

SPARE

CSM CONTROL
STATION IS IN
CONTROL

CSD CONTROL
STATION IS IN
CONTROL

RAISE
PACKAGE
STOP #18

RAISE
PACKAGE
STOP #22

BUMP TURNER
PRESSURE
VALVE (SW 0)

BUMP TURNER
PRESSURE
VALVE (SW 1)

BUMP TURNER
PRESSURE
VALVE (SW 2)

ROSS AIR
DUMP VALVE
RESET SOLENOID

201 (- LN -)

(- LN -) 202

| | | | | | | | | | | |
|-----|--|------|-------------|----|-------------|---|---------|----------------|-------|---------|
| REV | | DATE | DESCRIPTION | BY | CUSTOMER | DIAGEO NORTH AMERICA INC. RELAY, MD. | BY | HEDDERICH | DATE | 1/13/10 |
| | | | | | TITLE | CONTROL VOLTAGE SCHEMATIC | CAD NO. | EK228L01SC000A | SHEET | 023 |
| | | | | | DRAWING NO. | EK228L01SC/023 | | | | |



01
02
03
04
05
06
07
08
09
10
11
12
13
14
15
16
17
18
19
20

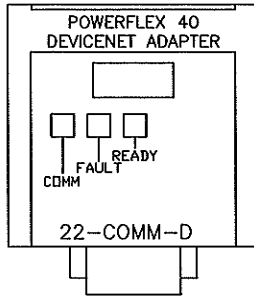

SWITCHES 1-6 DETERMINE NODE ADDRESS

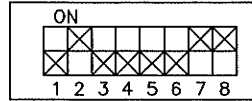

For Node Address settings, SW1-SW6 are set in binary. SW1 is LSD and SW6 is MSD.

SWITCHES 7 & 8 DETERMINE BAUD RATE

| BAUD RATE | SWITCH 7 | SWITCH 8 |
|---|----------|----------|
| 125 KBPS | 0 | 0 |
| 250 KBPS | 1 | 0 |
| 500 KBPS | 0 | 1 |
| Baud rate Set by DeviceNet parameters 02 & 04 | 1 | 1 |

Set Baud Rate to: "Set by DNet software" (= 11)
(set DNet parameter 104 to 500k baud for distances not over 328ft.)

DEVICE NET WIRING FOR VFD 01 (INFEED BELT)
RESISTOR IS REQUIRED ONLY IF THIS IS AN END TERMINATION

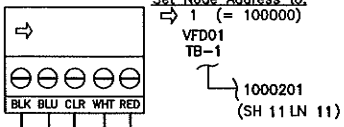

Set Node Address to: 1 (= 100000)
VFD01 TB-1
1000201 (SH 11 LN 11)

From Dnet Module (S 15 LN 19)

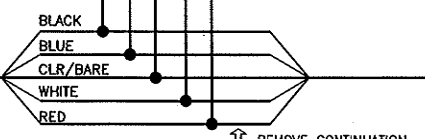

| | |
|----------|------------|
| BLACK | = -V |
| BLUE | = CAN LOW |
| CLR/BARE | = DRAIN |
| WHITE | = CAN HIGH |
| RED | = +V |

REMOVE CONTINUATION LINES IF ONLY ONE VFD IS USED.

DEVICE NET WIRING FOR VFD 02 (ROW FORMER)
RESISTOR IS REQUIRED ONLY IF THIS IS AN END TERMINATION

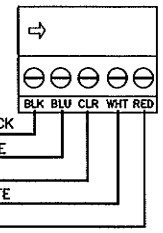

Set Node Address to: 2 (= 010000)
VFD02 TB-1
1000201 (SH 11 LN 07)

DEVICE NET WIRING FOR VFD 03 (ROW PUSHER)
RESISTOR IS REQUIRED ONLY IF THIS IS AN END TERMINATION

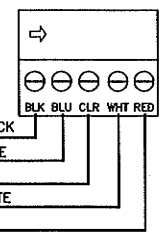

Set Node Address to: 3 (= 110000)
VFD03 TB-1
1000201 (SH 11 LN 11)

DEVICE NET WIRING FOR VFD 04 (LAYER PUSHER)
RESISTOR IS REQUIRED ONLY IF THIS IS AN END TERMINATION

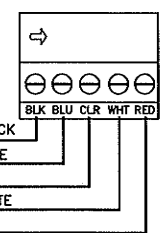

Set Node Address to: 4 (= 001000)
VFD04 TB-1
1000201 (SH 11 LN 11)

DEVICE NET WIRING FOR VFD 08 (HOIST CDLR)
RESISTOR IS REQUIRED ONLY IF THIS IS AN END TERMINATION

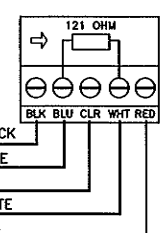

Set Node Address to: 8 (= 000100)
VFD08 TB-1
1000201 (SH 11 LN 11)

DEVICE NET WIRING FOR VFD 08A (HOIST FILLER SECTION)
RESISTOR IS REQUIRED ONLY IF THIS IS AN END TERMINATION

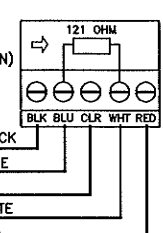

Set Node Address to: 9 (= 100100)
VFD08A TB-1
1000201 (SH 11 LN 11)

IMPORTANT: Insure that factory installed jumper on terminals 1-11 is removed. Also insure that Setup DIP switch is set to Source (SRC)

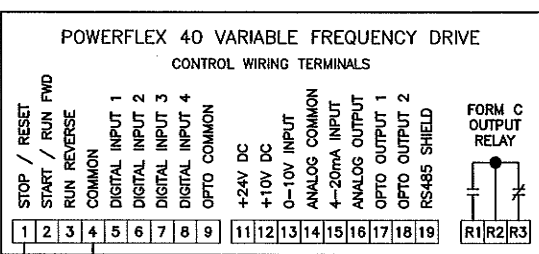

SRM controlled 24VDC 202 (SC 11 LN 17)

1000201 (MACHINE STOP CONTROL)

(S 25 LN 06) DNet Continuation

| | | | | | | | | | |
|-----|------|-------------|----|----------|---|----|-----------|-------------|----------------|
| REV | DATE | DESCRIPTION | BY | CUSTOMER | DIAGEO NORTH AMERICA INC. RELAY, MD. | BY | HEDDERICH | DATE | 1/13/10 |
| | | | | TITLE | CONTROL VOLTAGE SCHEMATIC | | | CAD NO | EK228L01SC000A |
| | | | | | | | | SH | 024 |
| | | | | | | | | DRAWING NO. | EK228L01SC/024 |



01
02
03
04
05
06
07
08
09
10
11
12
13
14
15
16
17
18
19
20

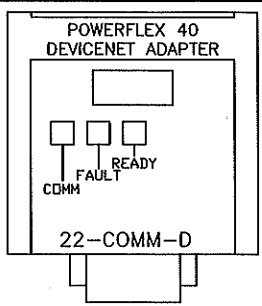
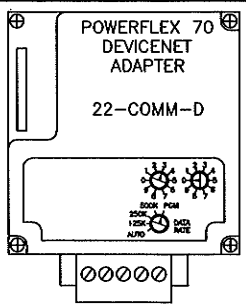

SWITCHES 1-6 DETERMINE NODE ADDRESS

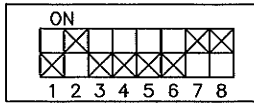

For Node Address settings, SW1-SW6 are set in binary. SW1 is LSD and SW6 is MSD.

SWITCHES 7 & 8 DETERMINE BAUD RATE

| BAUD RATE | SWITCH 7 | SWITCH 8 |
|---|----------|----------|
| 125 KBPS | 0 | 0 |
| 250 KBPS | 1 | 0 |
| 500 KBPS | 0 | 1 |
| Baud rate Set by DeviceNet parameters 02 & 04 | 1 | 1 |

Set Baud Rate to: "Set by DNet software" (= 11)
(set DNet parameter 104 to 500k baud for distances not over 328ft.)

DEVICE NET WIRING FOR VFD 011 (DISCHARGE #1)
RESISTOR IS REQUIRED ONLY IF THIS IS AN END TERMINATION

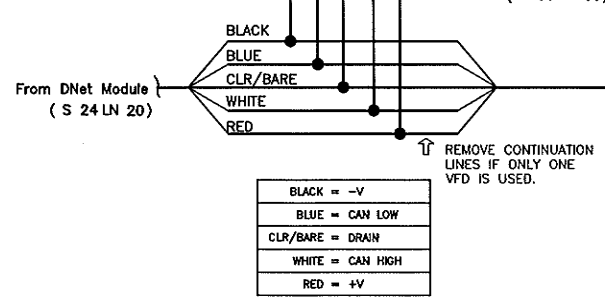
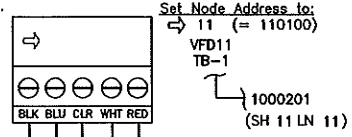

DEVICE NET WIRING FOR VFD 07 (HOIST)
RESISTOR IS REQUIRED ONLY IF THIS IS AN END TERMINATION

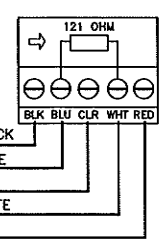

IMPORTANT:
Insure that factory installed jumper on terminals 1-11 is removed.
Also insure that Setup DIP switch is set to Source (SRC)

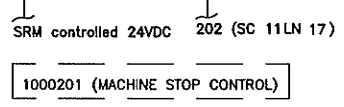
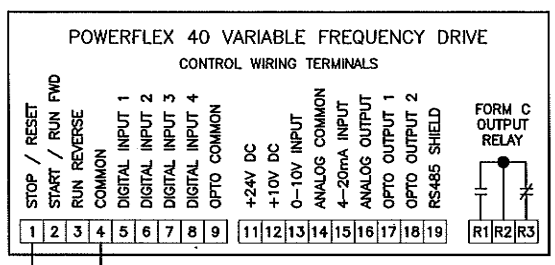

DeviceNet Connections

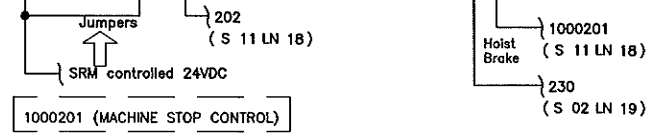
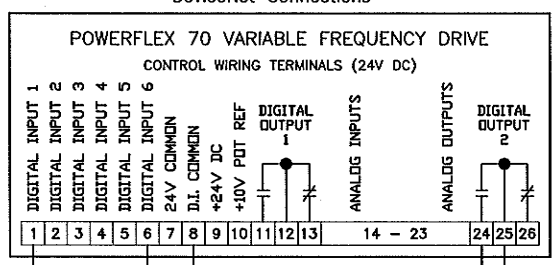

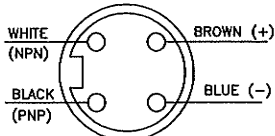
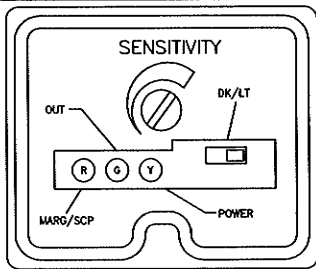

NOTE:
 COLOR CODE SHOWN IS FOR BRAD HARRISON CABLE NUMBERS 41107E, 41108E, S/41108E3M, 41109E, 61110E AND 61165.

INSTALLATION NOTES:

- SET "LT/DK" SWITCH TO POSITION INDICATED IN CHART BELOW.
- ADJUST "SENSITIVITY" POTENTIOMETER:
 - WITH EYE POWERED AND ALIGNED TO REFLECTOR, TURN POTENTIOMETER FULLY COUNTERCLOCKWISE.
 - TURN POTENTIOMETER CLOCKWISE SLIGHTLY BEYOND THE POINT WHERE THE "MARG/SCP" INDICATOR COMES BACK ON.

ALLEN BRADLEY
 42GRU-9200-QD1
 (POLARIZED
 RETROREFLECTIVE)
 10-40 VDC
 NPN/PNP
 4 PIN MINI-STYLE
 CONNECTOR

| PHOTOEYE NAME | CABLE WIRE COLORS | | | | LT/DK SWITCH |
|---------------|-------------------|-------|---------|------|--------------|
| | BROWN | WHITE | BLACK | BLUE | |
| TYPICAL | 201 | N/C | SIGNAL | 202 | LT |
| PE1 | 201 | N/C | 1000300 | 202 | LT |
| PE1EOR | 201 | N/C | 1000301 | 202 | LT |
| PE2 | 201 | N/C | 1000303 | 202 | LT |
| PE6A | 201 | N/C | 1000305 | 202 | LT |
| PE6B | 201 | N/C | 1000306 | 202 | LT |
| PE6J | 201 | N/C | 1000307 | 202 | LT |
| PE7 | 201 | N/C | 1000308 | 202 | LT |
| PE8 | 201 | N/C | 1000309 | 202 | LT |
| PE10 | 201 | N/C | 1000310 | 202 | LT |
| PE10J | 201 | N/C | 1000311 | 202 | LT |
| PE11A | 201 | N/C | 1000402 | 202 | LT |
| PE12 | 201 | N/C | 1000313 | 202 | LT |
| PE14A | 201 | N/C | 1000314 | 202 | LT |
| PE17 | 201 | N/C | 1000514 | 202 | LT |
| PE20 | 201 | N/C | 1000515 | 202 | LT |

SICK WT27-2F410

Background suppression proximity sensor.

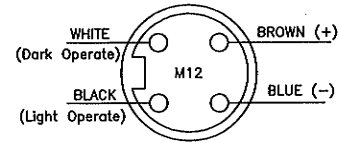

NOTE:
 COLOR CODE SHOWN IS FOR BRAD HARRISON CABLE NUMBER 80459-A OR 80449-A.

| PHOTOEYE NAME | CABLE WIRE COLORS | | | |
|---------------|-------------------|-------|---------|------|
| | BROWN | WHITE | BLACK | BLUE |
| TYPICAL | 201 | - | SIGNAL | 202 |
| PE2J | 201 | - | 1000304 | 202 |

DISCHARGE MUTING EYES

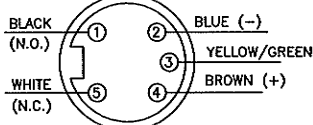
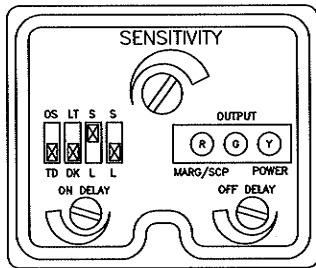

NOTE:
 COLOR CODE SHOWN IS FOR BRAD HARRISON CABLE NUMBER 105000A07M100

INSTALLATION NOTES:

- SET DIP SWITCHES TO POSITIONS SHOWN.
- ADJUST ON DELAY FOR "0" SECONDS
 ADJUST OFF DELAY FOR APROX 3 SECONDS AFTER LOAD CLEARS LIGHT CURTAIN.
- ADJUST "SENSITIVITY" POTENTIOMETER:
 - WITH EYE POWERED AND ALIGNED TO REFLECTOR, TURN POTENTIOMETER FULLY COUNTERCLOCKWISE.
 - TURN POTENTIOMETER CLOCKWISE SLIGHTLY BEYOND THE POINT WHERE THE "MARG/SCP" INDICATOR COMES BACK ON.

ALLEN BRADLEY 42GTU-9201-QD
 POLARIZED RETROREFLECTIVE TIMING EYE
 10-55V DC/20-40V AC SPDT EM RELAY
 5 PIN MINI QD CONNECTOR

| PHOTOEYE NAME | CABLE WIRE COLORS | | | | LT/DK SWITCH | DEVICE USAGE | |
|---------------|-------------------|---------|-------|-------|--------------|--------------|------------|
| | BROWN | YEL/GRN | BLACK | WHITE | | | BLUE |
| PEMA1 | 1000201 | 803A | 804A | | 202 | DK | MUTING EYE |
| PEMA2 | 1000201 | 803B | 804B | | 202 | DK | MUTING EYE |

DC INDUCTIVE PROXIMITY SWITCH

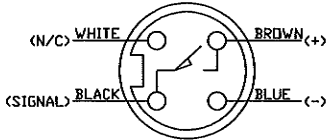

NOTE:
WIRE COLOR CODE SHOWN IS FOR BRAD HARRISON CABLE NUMBERS
41107E, 41108E, S/41108E3M, 41109E, 61110E AND 61165.

ALLEN-BRADLEY OR TURCK 3-WIRE DC, WITH MINI STYLE QUICK DISCONNECT

| PROX SWITCH DESIGNATION | CABLE CONNECTIONS | | | | DEVICE USAGE |
|----------------------------|-------------------|-------|---------|------|-------------------------|
| | BROWN | WHITE | BLACK | BLUE | |
| TYPICAL | 201 | N/C | SIGNAL | 202 | - |
| PX3 | 201 | N/C | 1000204 | 202 | ROW PUSHER HOME |
| PX3A | 201 | N/C | 1000205 | 202 | FULL LYR SIZE |
| PX4 | 201 | N/C | 1000206 | 202 | APRON OPEN |
| PX5 | 201 | N/C | 1000207 | 202 | APRON CLOSED |
| PX8H | 201 | N/C | 1000208 | 202 | PWRD HOIST TABLE DOWN |
| PX68A | 201 | N/C | 1000212 | 202 | LEFT HOIST CHAIN SLACK |
| PX68B | 201 | N/C | 1000213 | 202 | RIGHT HOIST CHAIN SLACK |
| PX75A | 201 | N/C | 1000214 | 202 | LEFT HST BLOCK STOWED |
| PX75B | 201 | N/C | 1000215 | 202 | RIGHT HST BLOCK STOWED |

| | | | | | | | | | | | |
|-----|------|-------------|----|---|----------|---|-------------|----------------|--------|----------------|-----|
| REV | DATE | DESCRIPTION | BY |  | CUSTOMER | DIAGED NORTH AMERICA INC. RELAY, MD. | BY | HEDDERICH | DATE | 1/13/10 | |
| | | | | | TITLE | CONNECTION DIAGRAM | DRAWING NO. | EK228L01CD/002 | CAD NO | EK228L01CD000A | SHT |

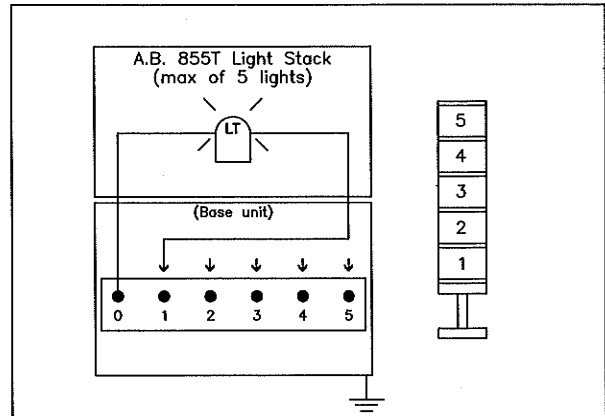
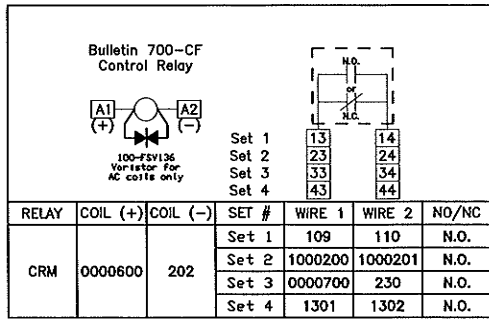

NOTE 1: TERMINAL STRIP IS LOCATED IN THE LIGHT STACK BASE.
 TERMINAL # 0 IS THE COMMON (AC OR DC) FOR ALL LIGHT SECTIONS
 TERMINAL # 1 IS FOR THE BOTTOM LIGHT SECTION, # 5 IS THE TOP LIGHT

| LIGHT NAME | SIGNAL WIRE | TERMINAL # | COMMON | STEADY/FLASH | COLOR |
|------------|-------------|------------|--------|--------------|-------|
| LT1 | 0000900 | 1 | 202 | S | RED |
| LT2 | 0000901 | 2 | 202 | S | AMBER |

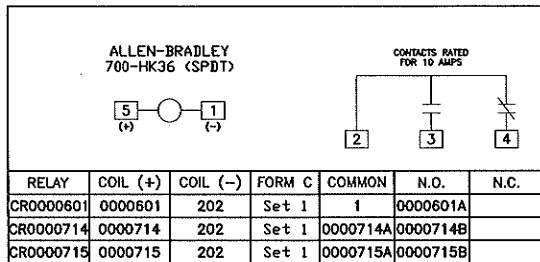

82 Series Valve Manifold
WIRE WITH 12 Conductor Cable # 2700706

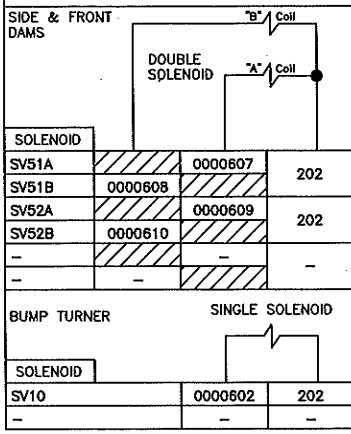

MAC, 3 WAY, SERIES 100 Wired with 4-Pin QD Cable and 3 Conductor Cable # 2700702

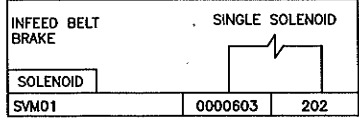

SLIPSHEET DISPENSER
82 Series Valve Manifold
Use continuous flex cable for wiring on boom (ie 2700993)

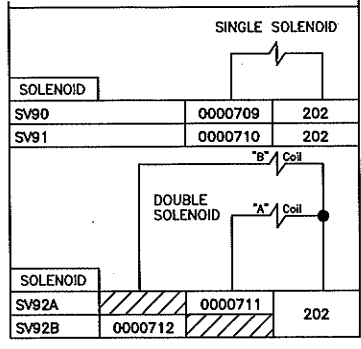

35 Series Valve Manifold
WIRE WITH 7 Conductor Cable # 2700705

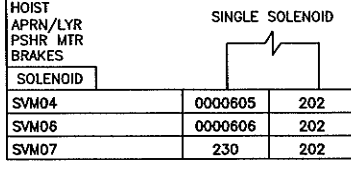

ROSS AIR DUMP VALVE
(ie 2700993)

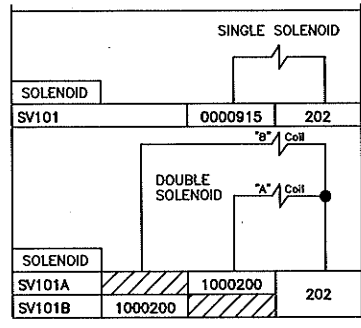

35 Series Valve Manifold
WIRE WITH 12 Conductor Cable # 2700706

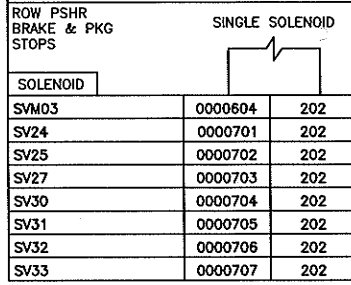

35 Series Valve Manifold
WIRE WITH 12 Conductor Cable # 2700706

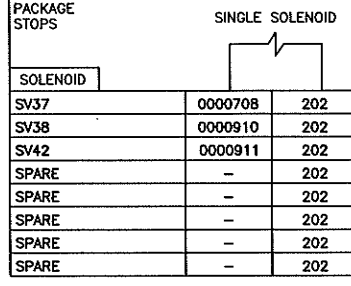

| ALLEN BRADLEY PowerFlex 40 FREQUENCY DRIVE SETTINGS with 22-COMM-D/E (ver 7.00) | | VFD01 | VFD02 | VFD03 | VFD04 |
|--|---------------------|-----------------|-----------------|----------------|----------------|
| | | INFEEED BELT | ROW FORMER | ROW PUSHER | LAYER PUSHER |
| PROGRAM INSTANCE # | DESCRIPTION | USER SETTINGS | USER SETTINGS | USER SETTINGS | USER SETTINGS |
| P033 | OVERLOAD CURRENT | 1.5 | 1.5 | 2.1 | 2.7 |
| P034 | MINIMUM FREQUENCY | 10 | 10 | 10 | 10 |
| P035 | MAXIMUM FREQUENCY | 90 | 90 | 90 | 90 |
| P036 | START SOURCE | 5 (COMM PORT) | 5 (COMM PORT) | 5 (COMM PORT) | 5 (COMM PORT) |
| P037 | STOP MODE | 5 (COAST) | 5 (COAST) | 5 (COAST) | 5 (COAST) |
| P038 | SPEED REFERENCE | 5 (COMM PORT) | 5 (COMM PORT) | 5 (COMM PORT) | 5 (COMM PORT) |
| P039 | ACCEL TIME 1 | 0.3 | 0.3 | 0.3 | 0.3 |
| P040 | DECEL TIME 1 | .5 | .5 | .5 | .5 |
| A095 | REVERSE DISABLE | 1 (REV DISABLE) | 1 (REV DISABLE) | 0 (REV ENABLE) | 0 (REV ENABLE) |
| A105 | COMM LOSS | 2 (STOP) | 2 (STOP) | 2 (STOP) | 2 (STOP) |
| A126 | MOTOR NAMEPLATE FLA | 1.5 | 1.5 | 2.1 | 2.7 |
| 18 | COMM FAULT ACTION | 1 (STOP) | 1 (STOP) | 1 (STOP) | 1 (STOP) |
| 19 | IDLE FAULT ACTION | 1 (STOP) | 1 (STOP) | 1 (STOP) | 1 (STOP) |
| BOOTP DISABLED / AUTODETECT FOR EN RATE CFG | | | | | |

| ALLEN BRADLEY PowerFlex 40 FREQUENCY DRIVE SETTINGS with 22-COMM-D/E (ver 7.00) | | VFD08 | VFD08A | VFD11 |
|--|---------------------|------------------|-----------------|-----------------|
| | | HOIST TABLE CDLR | FILLER SECTION | DISCH CNVYR 1 |
| PROGRAM INSTANCE # | DESCRIPTION | USER SETTINGS | USER SETTINGS | USER SETTINGS |
| P033 | OVERLOAD CURRENT | 2.7 | 1.5 | 2.7 |
| P034 | MINIMUM FREQUENCY | 10 | 10 | 10 |
| P035 | MAXIMUM FREQUENCY | 90 | 90 | 90 |
| P036 | START SOURCE | 5 (COMM PORT) | 5 (COMM PORT) | 5 (COMM PORT) |
| P037 | STOP MODE | 5 (COAST) | 5 (COAST) | 5 (COAST) |
| P038 | SPEED REFERENCE | 5 (COMM PORT) | 5 (COMM PORT) | 5 (COMM PORT) |
| P039 | ACCEL TIME 1 | 0.3 | 0.3 | 0.3 |
| P040 | DECEL TIME 1 | .5 | .5 | .5 |
| A095 | REVERSE DISABLE | 1 (REV DISABLE) | 1 (REV DISABLE) | 1 (REV DISABLE) |
| A105 | COMM LOSS | 2 (STOP) | 2 (STOP) | 2 (STOP) |
| A126 | MOTOR NAMEPLATE FLA | 2.7 | 1.5 | 2.7 |
| 18 | COMM FAULT ACTION | 1 (STOP) | 1 (STOP) | 1 (STOP) |
| 19 | IDLE FAULT ACTION | 1 (STOP) | 1 (STOP) | 1 (STOP) |
| BOOTP DISABLED / AUTODETECT FOR EN RATE CFG | | | | |

| | | | | | | | | | | |
|-----|------|-------------|----|---|----------|---|----------------|----------------|------|---------|
| REV | DATE | DESCRIPTION | BY |  | CUSTOMER | DIAGEO NORTH AMERICA INC. RELAY, MD. | BY | HEDDERICH | DATE | 1/13/10 |
| | | | | | TITLE | POWER FLEX 40 PARAMETERS | DWG NO. | EK228L01CD000A | SHT | 006 |
| | | | | | | DRAWING NO. | EK228L01CD/006 | | | |

| ALLEN-BRADLEY POWERFLEX 70 EC DRIVE SETTINGS | | DISCRETE I/O | 20-COMM-D (or E) |
|--|---|---------------|-------------------|
| CONSTANT No. | DESCRIPTION | USER SETTINGS | USER SETTINGS |
| 15 HP WITH 2 WIRE CONTROL | | HOIST | HOIST |
| MOTOR DATA | | | |
| 41 | NAMEPLATE VOLTS | | 460 VOLTS |
| 42 | NAMEPLATE FLA | | 18.90 AMPS |
| 43 | NAMEPLATE HERTZ | | 60HZ |
| 44 | NAMEPLATE RPM | | 1765 |
| 45 | NAMEPLATE POWER | | 15 H.P. |
| 54 | MAXIMUM VOLTAGE | | 460 VOLTS |
| TORQ ATTR | | | |
| 57 | FLUX UP MODE | | 1 (AUTOMATIC) |
| 58 | FLUX UP TIME | | 0.18 |
| SPD LIMITS | | | |
| 80 | SPEED MODE | | 0 (OPEN LOOP) |
| 81 | MIN. SPEED | | 15HZ |
| 82 | MAX. SPEED | | 90HZ |
| SPEED REF | | | |
| 90 | SPEED REFERENCE A SELECT | | 22 (DPI PORT 5) |
| 93 | SPEED REFERENCE B SELECT | | DEFAULT |
| DISCRETE SPD | | | |
| 100 | JOG SPEED | | DEFAULT |
| 101 | SPEED REFERENCE 1 | | DEFAULT |
| 102 | SPEED REFERENCE 2 | | DEFAULT |
| 103 | SPEED REFERENCE 3 | | 85HZ |
| RAMP RATE | | | |
| 140 | ACCEL TIME 1 | | 0.6 |
| 142 | DECEL TIME 1 | | 0.5 |
| 146 | S CURVE % | | 0 |
| 148 | CURR LIMIT VAL | | 33.0 |
| 149 | CURR LIMIT GAIN | | 500 |
| 151 | PWM FREQUENCY | | 2.0 |
| STOP/BRAKE | | | |
| 155 | STOP MODE A | | 1 (RAMP) |
| 156 | STOP MODE B | | 0 (COAST) |
| 161 | BUS REG MODE A | | 2 (DYNAMIC BRAKE) |
| 162 | BUS REG MODE B | | 2 (DYNAMIC BRAKE) |
| 163 | DB RESISTOR TYPE | | 1 (EXTERNAL) |
| 238 | FAULT CONFIG 1 | | 72 |
| DIGITAL INPUT | | | |
| 361 | IN 1 SELECT | | 1 (ENABLE DRIVE) |
| 362 | IN 2 SELECT | | NOT USED |
| 363 | IN 3 SELECT | | NOT USED |
| 364 | IN 4 SELECT | | NOT USED |
| 365 | IN 5 SELECT | | NOT USED |
| 366 | IN 6 SELECT | | 1 (ENABLE DRIVE) |
| DIGITAL OUT | | | |
| 380 | DIGITAL OUT 1 SELECT | | 1 (FAULT) |
| 384 | DIGITAL OUT 2 SELECT | | 10 (AT FREQ) |
| 385 | DIGITAL OUT 2 LEVEL | | 2.5HZ |
| DEVICENET MODULE | | | |
| 397 | COMM FLT ACTION | | STOP |
| 398 | IDLE FLT ACTION | | STOP |
| ETHERNET MODULE | | | |
| 21 | BOOTP DISABLED / AUTODETECT FOR EN RATE CFG | | |
| 21 | COMM FLT ACTION | | STOP |
| 22 | IDLE FLT ACTION | | STOP |

NOTES:

- 1) ALL SETTINGS NOT LISTED ARE LEFT AT FACTORY DEFAULT SETTING.
- 2) FOLLOW THE S.M.A.R.T. START-UP PROCEDURES WHEN SETTING UP THE DRIVE.
IF USING DNET, THE "START" SIGNAL MUST BE FORCED ON IN THE PLC PROGRAM.
Note that after running this procedure, some of the above settings may be overwritten.

| | | | | | | | | | | | |
|-----|------|-------------|----|---|-------------|---|----|-----------|---------|----------------|-----|
| REV | DATE | DESCRIPTION | BY |  | CUSTOMER | DIAGEO NORTH AMERICA INC. RELAY, MD. | BY | HEDDERICH | DATE | 1/13/10 | |
| | | | | | TITLE | POWER FLEX 70 PARAMETERS | | | CAD NO. | EK228L01CD000A | SHT |
| | | | | | DRAWING NO. | EK228L01CD/007 | | | | | |

SMC ITV2000 Programmable Pressure Regulator Setup

To Unlock:

- 1.) Press and hold the down key for 2 seconds or longer. The display will blink **LOC**.
- 2.) Press the set key to unlock the keys, or Press the up key to cancel.

To Lock:

- 1.) Press and hold the up key for 2 seconds or longer. The display will blink **UNL**.
- 2.) Press the set key to lock the keys, or Press the down key to cancel.

Programming The Set-Points:

When setting the minimum pressure and maximum pressure values, the new values take effect as soon as the **SET** key is pressed. Use caution to avoid damage or injury.

- 1.) Unlock the Keypad
- 2.) Set the minimum pressure (**F_1**)
 - a. Press the **UP** and **DOWN** keys until the display shows the desired minimum pressure.
 - b. Press and release the **SET** key to continue to the next step.
- 3.) Set the maximum pressure (**F_2**)
 - a. Press the **UP** and **DOWN** keys until the display shows the desired maximum pressure.
 - b. Press and release the **SET** key to continue to the next step.
- 4.) Set the monitor pressure (**P_1**)
 - a. Press the **UP** and **DOWN** keys until the display shows the desired monitor pressure.
 - b. Press and release the **SET** key to continue to the next step.
- 5.) Set the monitor pressure (**P_2**)
 - a. Press the **UP** and **DOWN** keys until the display shows the desired monitor pressure.
 - b. Press and release the **SET** key to finish the setup.
 - c. The display returns to the current pressure.

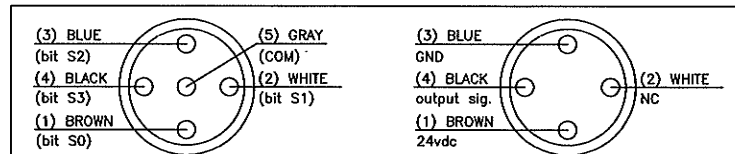

NOTE:
COLOR CODE SHOWN IS FOR BRAD HARRISON CABLE
NUMBER 805000A09M100

SMC ITV SERIES PRESSURE REGULATOR

| OUTPUT | 0000912 | 0000913 | 0000914 | - | | |
|--------------|---------|---------|---------|--------|----------|--|
| PRESSURE BIT | BIT S0 | BIT S1 | BIT S2 | BIT S3 | PRESSURE | |
| MINIMUM (F1) | | | | | 0 PSI | |
| MAXIMUM (F2) | | | | | 45 PSI | |
| PRESSURE P1 | OFF | OFF | OFF | OFF | 0 PSI | |
| PRESSURE P2 | ON | OFF | OFF | OFF | 15 PSI | |
| PRESSURE P3 | OFF | ON | OFF | OFF | 20 PSI | |
| PRESSURE P4 | ON | ON | ON | OFF | 25 PSI | |
| PRESSURE P5 | OFF | OFF | ON | OFF | 30 PSI | |
| PRESSURE P6 | ON | OFF | ON | OFF | 35 PSI | |
| PRESSURE P7 | OFF | ON | ON | OFF | 40 PSI | |
| PRESSURE P8 | ON | ON | ON | OFF | 45 PSI | |

| | | | | | | | | | | | |
|-----|------|-------------|----|--|----------|---|----|-------------|----------------|----------------|-----|
| REV | DATE | DESCRIPTION | BY | | CUSTOMER | DIAGEO NORTH AMERICA INC. RELAY, MD. | BY | HEDDERICH | DATE | 1/13/10 | |
| | | | | | TITLE | CONNECTION DIAGRAM | | | CAD NO. | EK228L01CD000A | SHT |
| | | | | | | | | DRAWING NO. | EK228L01CD/008 | | |

CONTROL RELIABLE AIR DUMP SOLENOID (ROSS)

- This valve has THREE solenoids. The two safety circuit solenoids control redundant poppet valves that actually dump the air. The third solenoid controls a reset valve.
- If either one or both of the safety circuit solenoids de-energizes, the valve will dump air. These two solenoids MUST be controlled by both the master safety relay and the CRM, not a PLC output.
- The reset solenoid must be pulsed before safety circuit solenoids can be turned back on to close the valve. The reset solenoid is controlled by a PLC output. This must occur while the SRM is off and there must be air pressure at the valve's input. The valve has a pressure switch to monitor air supplied to the valve. (It does not monitor output pressure.) This pressure switch must be wired to a PLC input. (terminal #1 is common, terminal #3 is N.O. and is closed when the valve is ready to run)
- Do NOT turn on the reset solenoid for more than a second or two. A pulse is all that is needed to reset the valve. While the reset solenoid is on, air will escape from the valve, which makes it sound like it is leaking. This does not hurt anything, and is considered normal operation.
- Sometimes this valve will allow supply air to escape (leak) after the valve has opened. This is not supposed to happen according to the Air Specialist guy, but apparently it occasionally does. Pulsing the reset solenoid typically corrects this leakage.

The following are two recommended methods for controlling the DM2 valve.

Method One (This method will apply to standard machines)

Use this method when the machine does NOT have manual air dump valves UPSTREAM of the DM2 valve that the operators are required to lock out prior to entering the machine..

- When the Master Safety Relay trips, the safety circuit solenoids are de-energized and a 1 sec timer starts.
- When this timer is done, the reset solenoid is energized and a second timer starts, preset is also 1 sec.
- When the second timer is done, the reset solenoid is de-energized and a 2 sec timer is started.
- When the third timer is done, check the pressure switch input. If it does NOT indicate that the valve is ready to run, trigger a message that states the air dump valve is faulted.
- Configure the reset timing logic such that pressing FAULT RESET on the PanelView will clear all the timers and repeat the reset sequence.
- The first timer allows the valve to completely open prior to reset.
- The second timer turns the reset off after it has done its job.
- The third timer allows the pressure switch time to react to the reset.
- Resetting the valve a second after it dumps has the advantage of greatly reducing the chances that the valve will "leak" after it opens.

Method Two

Use this method when the machine DOES have manual air dump valves UPSTREAM of the DM2 valve that the operators are required to lock out prior to entering the machine.

- When the Master Safety Relay trips, the safety circuit solenoids are de-energized and a 1 sec timer starts.
- When this timer is done, do nothing until the Master Safety Relay is reset. At this point, energize the reset solenoid and start a second timer, preset to 1 sec.
- When the second timer is done, de-energize the reset solenoid and start a 2 sec timer.
- When the third timer is done, check the pressure switch input. If it does NOT indicate that the valve is ready to run, trigger a message that states the air dump valve is faulted.
- Configure the reset timing logic such that pressing FAULT RESET on the PanelView will clear all the timers and repeat the reset sequence.
- The first timer allows the valve to completely open prior to reset.
- The second timer turns the reset off after it has done its job.
- The third timer allows the pressure switch time to react to the reset.
- Resetting the valve a second after it dumps to reduce the chances that the valve will "leak" is not an issue because the operators are opening up stream dump valves. The operator will open the manual air dump valve (hopefully) prior to resetting the SRM. By firing the reset solenoid AFTER the SRM is reset, air pressure should be present at the DM2 inlet. Without pressure at the inlet, the reset will not work.

| | | | | | | | |
|-----|------|---|----|--|--|-------------------------------|--|
| | |  | | CUSTOMER DIAGEO NORTH AMERICA INC. RELAY, MD. | | BY HEDDERICH DATE 1/13/10 | |
| | | | | TITLE CONNECTION DIAGRAM | | CAD NO EK228L01CD000A SHT 009 | |
| REV | DATE | DESCRIPTION | BY | DRAWING NO. EK228L01CD/009 | | | |

DO NOT SCALE
 UNLESS OTHERWISE SPECIFIED
 TOLERANCES ARE:
 FRACTIONS: $\pm 1/32"$
 DECIMALS:
 .XX $\pm .03"$
 .XXX $\pm .010"$
 ANGLES $\pm 1'$
 CONCENTRICITY: $.015"$ TIR

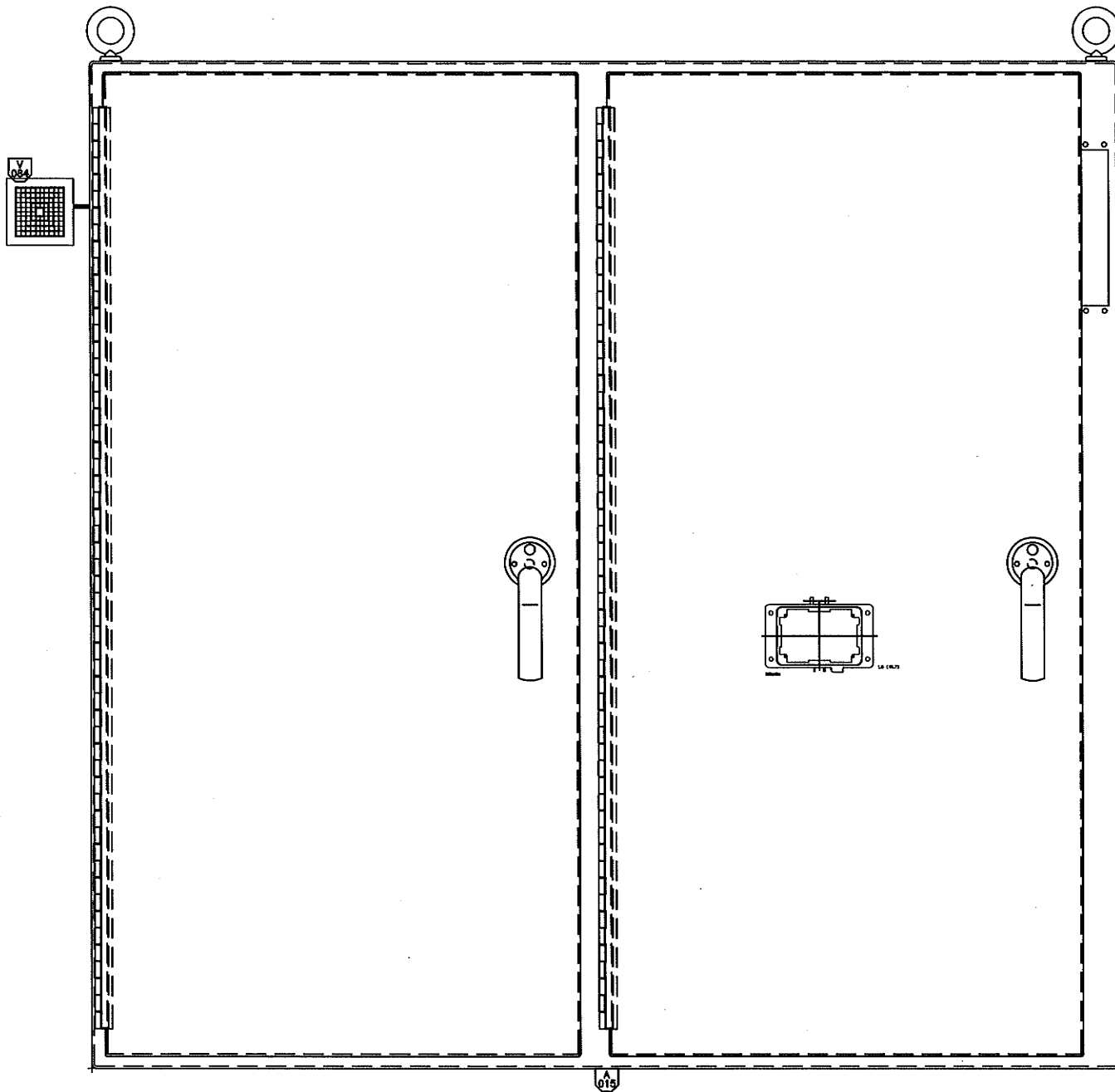

| | | | | | | | | | | | |
|-----|------|-------------|----|---|----------|---|-------------|----------------|---------|----------------|-----|
| REV | DATE | DESCRIPTION | BY |  | CUSTOMER | DIAGEO NORTH AMERICA INC. RELAY, MD. | BY | HEDDERICH | DATE | 1/13/10 | |
| | | | | | TITLE | MOTOR CONTROL ENCLOSURE LAYOUT | DRAWING NO. | EK228L01EN/001 | CAD NO. | EK228L01EN000A | SHT |

CENTER ON LEFT DOOR 3" FROM TOP OF DOOR

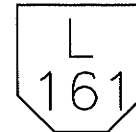

CENTER UNDER FKI LOGISTEX SIGN (L161) 10" FROM TOP OF DOOR

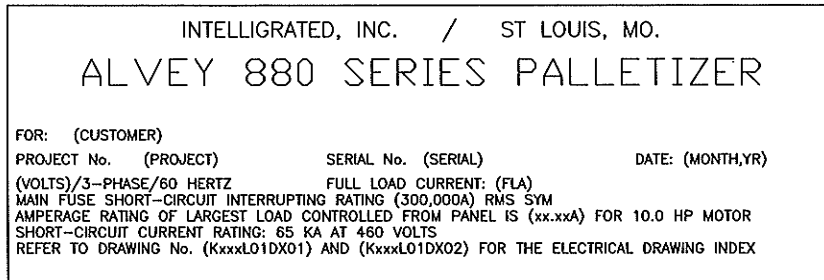

NOTE: This label is shown for location reference only. Use ShopNote #3 for actual engraving requirements

CENTER ON RIGHT DOOR 10" FROM TOP OF DOOR

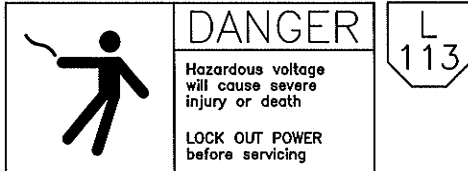

(ACTUAL SIZE = 2"x 4")

CENTER ON RIGHT DOOR 16" FROM TOP OF DOOR

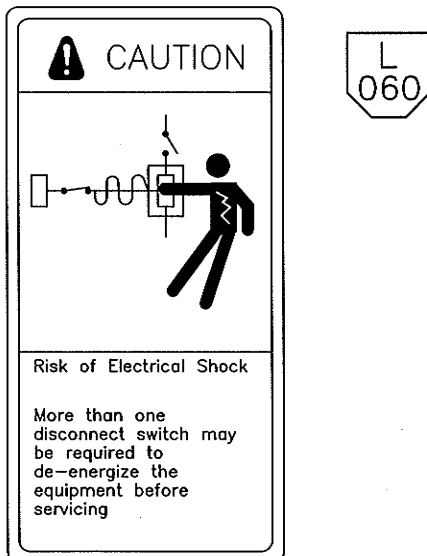

CENTER ON RIGHT DOOR 26" FROM TOP OF DOOR

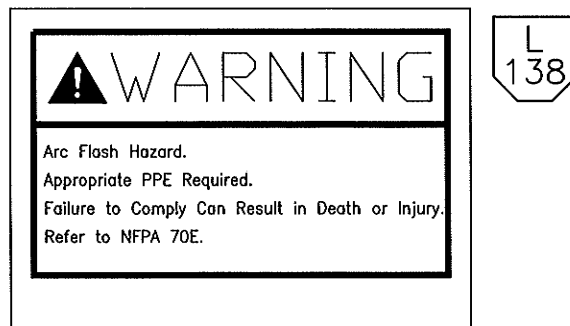

| | | | | | | | |
|-----|------|-------------|----|--|---|-------------------------------|-----------------|
| REV | DATE | DESCRIPTION | BY | | CUSTOMER DIAGED NORTH AMERICA INC. RELAY, MD. | BY HEDDERICH | DATE 1/13/10 |
| | | | | | | CAD NO. EK228L01EN000A | SHEET 002 |
| | | | | | TITLE MOTOR CONTROL ENCLOSURE DOOR SIGNS | DRAWING NO. EK228L01EN/002 | |

FOR PROPER MOUNTING OR DISMOUNTING OF THE POWERFLEX 40 FREQUENCY DRIVES THERE MUST BE A MINIMUM OF 1/4" BETWEEN THE TOP OF THE VFD AND THE BOTTOM OF THE DEVICE LABEL.

DO NOT SCALE UNLESS OTHERWISE SPECIFIED TOLERANCES ARE: FRACTIONS: ± 1/32" DECIMALS: .XX ± .03" .XXX ± .010" ANGLES ± 1° CONCENTRICITY: .015" TIR

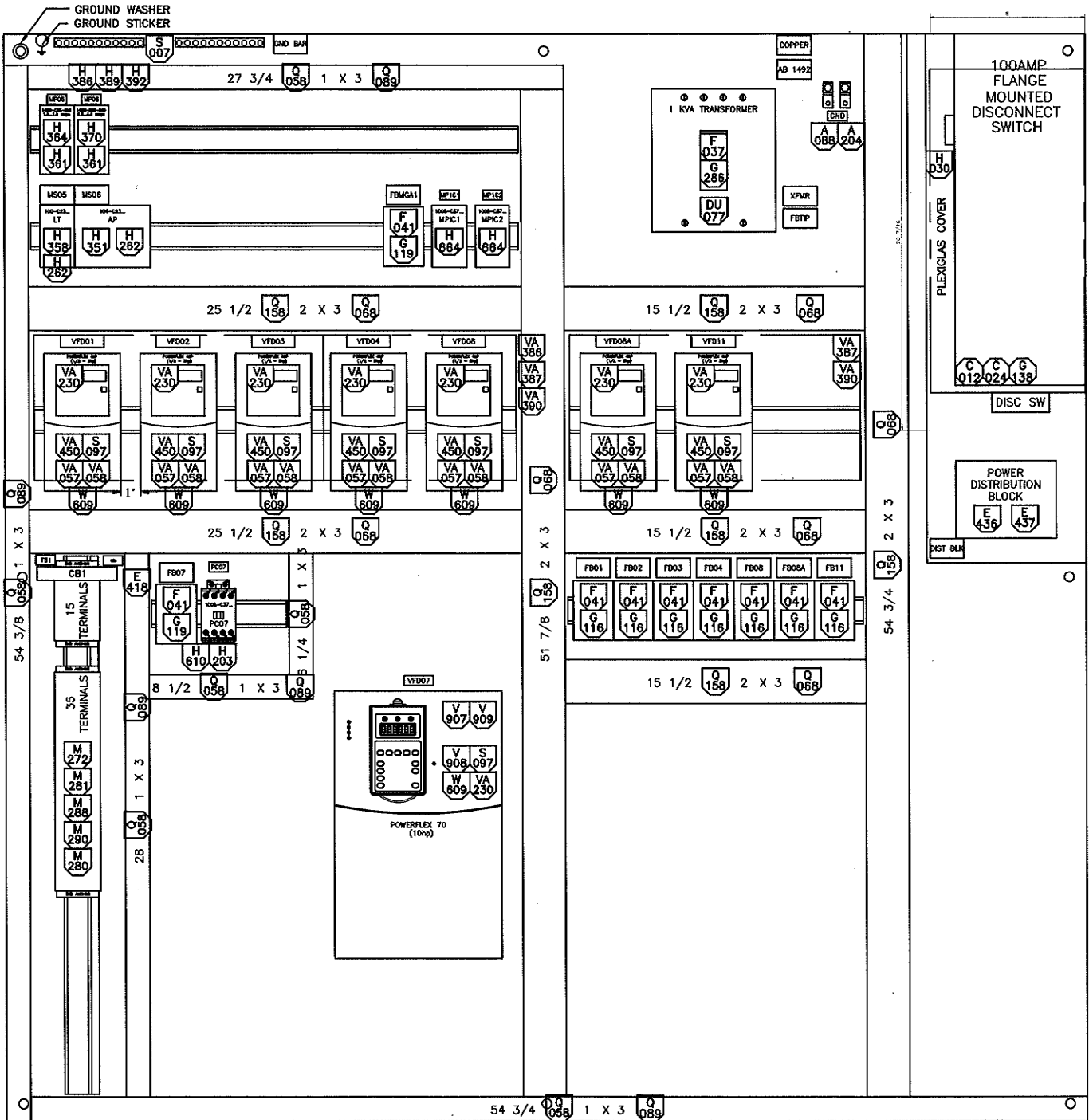

NOTE:
ALL PANEL WIRING TO ENTER TERMINAL STRIPS ON LEFT SIDE
AND TERMINAL LABELS ARE TO BE ON THE RIGHT SIDE OF THE TERMINALS

| | | | | | | | | | | | | |
|-----|--|------|-------------|----|-------------|--|---|---------|-----------|----------------|---------|-----|
| REV | | DATE | DESCRIPTION | BY | CUSTOMER | | DIAGEO NORTH AMERICA INC. RELAY, MD. | BY | HEDDERICH | DATE | 1/13/10 | |
| | | | | | TITLE | | MOTOR CONTROL PANEL LAYOUT | CAD NO. | | EK228L01EN000A | SHT | 003 |
| | | | | | DRAWING NO. | | EK228L01EN/003 | | | | | |



B 010 A-60P60

FOR PROPER MOUNTING OR
DISMOUNTING OF THE
POWERFLEX 40 FREQUENCY
DRIVES THERE MUST BE A
MINIMUM OF 1/4" BETWEEN
THE TOP OF THE VFD AND
THE BOTTOM OF THE DEVICE
LABEL.

DO NOT SCALE
UNLESS OTHERWISE SPECIFIED
TOLERANCES ARE:
FRACTIONS: ± 1/32"
DECIMALS:
.XX ± .03"
.XXX ± .010"
ANGLES ± 1°
CONCENTRICITY: .015" TIR

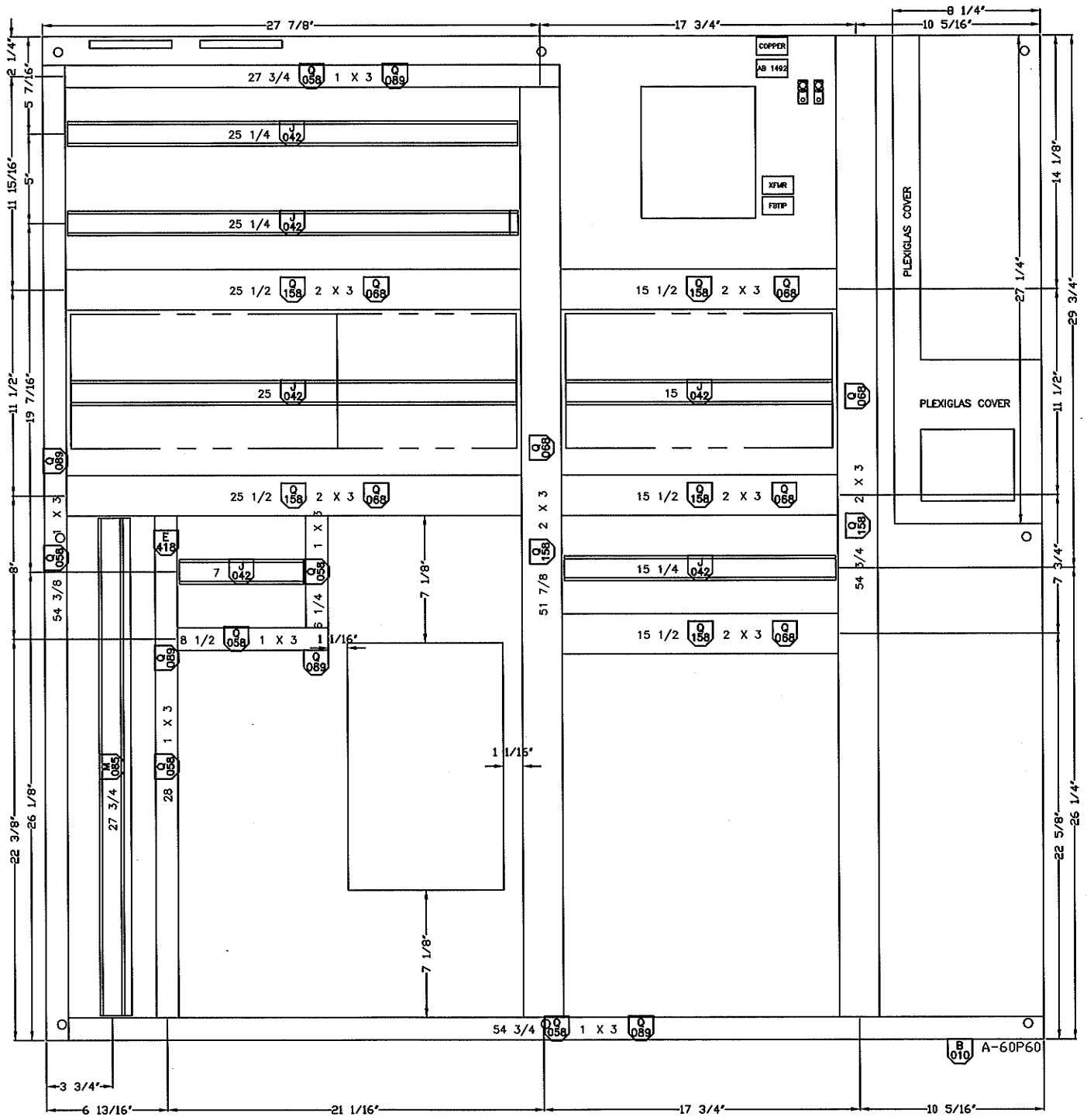

| | | | | |
|-----|------|---|--|--------------------------|
| | | CUSTOMER: DIAGEO NORTH AMERICA INC. RELAY, MD. | BY: HEDDERICH CAD NO.: EK228L01EN000A | DATE: 1/13/10 SH: 004 |
| REV | DATE | DESCRIPTION | TITLE: MOTOR CONTROL PANEL TEMPLATE DRAWING NO.: EK228L01EN/004 | |

SPARE SHEET FOR ADDITIONAL COMPONENTS

| | | | | | | | | | | | |
|-----|------|--|-------------|---|----------|---|-----------------------------------|-------------|----------------|----------------|-----|
| | | | |  | CUSTOMER | DIAGEO NORTH AMERICA INC. RELAY, MD. | BY | HEDDERICH | DATE | 1/13/10 | |
| | | | | | | | | | CAD NO. | EK228L01EN000A | SHT |
| REV | DATE | | DESCRIPTION | BY | | TITLE | MOTOR CONTROL PANEL TERMINAL LIST | DRAWING NO. | EK228L01EN/006 | | |

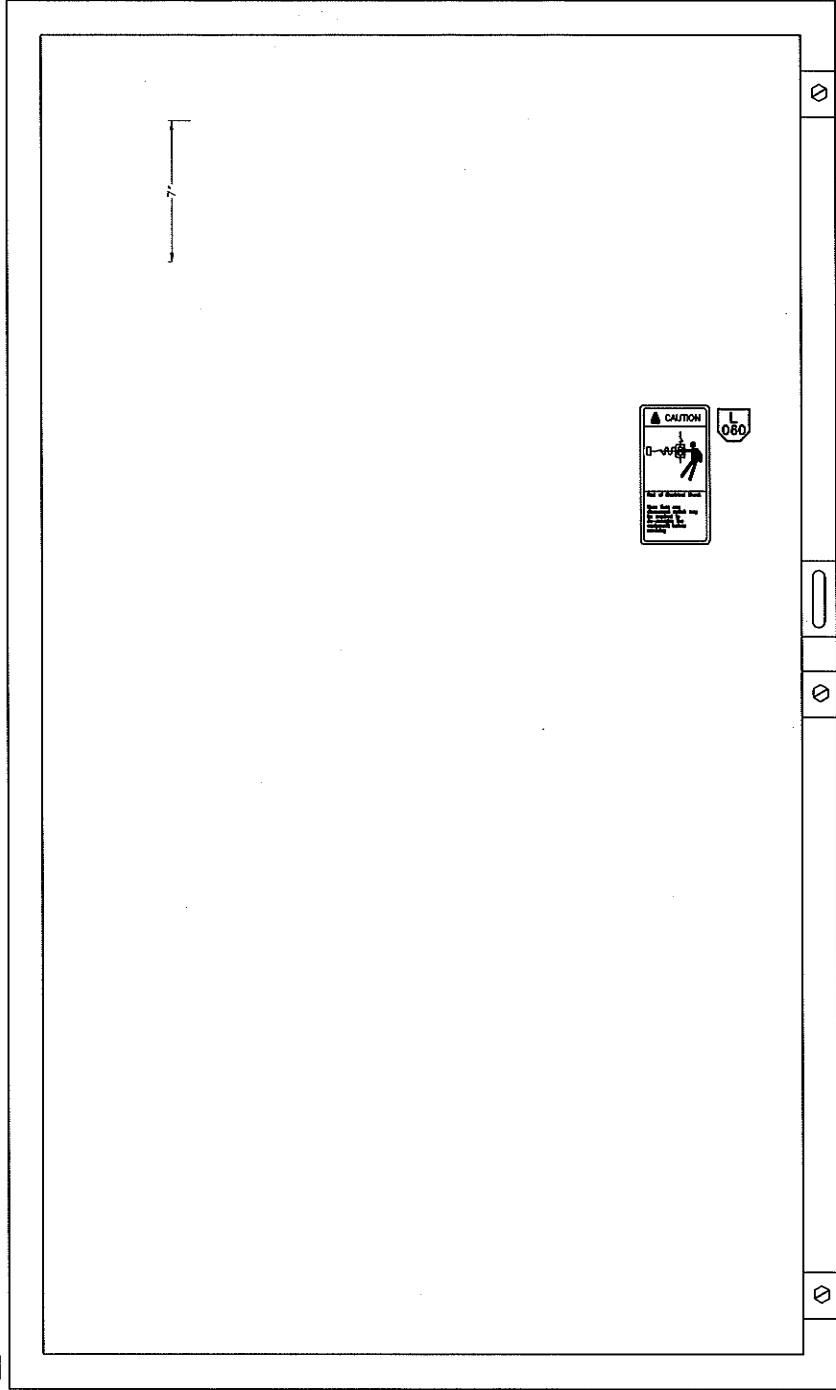

60" X 36" X 10" ENCLOSURE

| | | | | | | | | | |
|-----|------|-------------|----|---|---|-------------|------------------------------|---------|----------------|
| REV | DATE | DESCRIPTION | BY |  | CUSTOMER DIAGEO NORTH AMERICA INC. RELAY, MD. | BY | HEDDERICH | DATE | 1/13/10 |
| | | | | | | TITLE | PLC CONTROL ENCLOSURE LAYOUT | CAD NO. | EK228L01EN000A |
| | | | | | | DRAWING NO. | EK228L01EN/007 | | |

PLACE ON DOOR 16" FROM TOP 4" FROM RIGHT

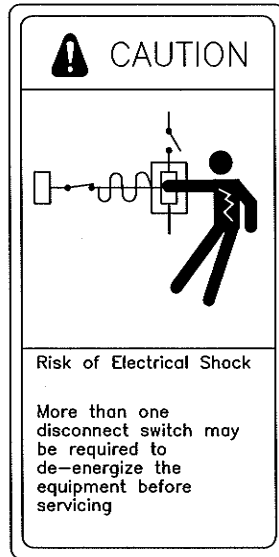

| | | | | | | | | | |
|-------------------------|--|--|--|---|--|---|--|---------------------------|--|
| | | | |  | | CUSTOMER DIAGEO NORTH AMERICA INC. RELAY, MD. | | BY HEDDERICH DATE 1/13/10 | |
| | | | | | | CAD NO. EK228L01EN000A | | SHF 008 | |
| REV DATE DESCRIPTION BY | | | | TITLE PLC CONTROL ENCLOSURE DOOR SIGNS | | DRAWING NO. EK228L01EN/008 | | | |

DO NOT SCALE
 UNLESS OTHERWISE SPECIFIED
 TOLERANCES ARE:
 FRACTIONS: ± 1/32"
 DECIMALS:
 .XX ± .03"
 .XXX ± .010"
 ANGLES ± 1°
 CONCENTRICITY: .015" TIR

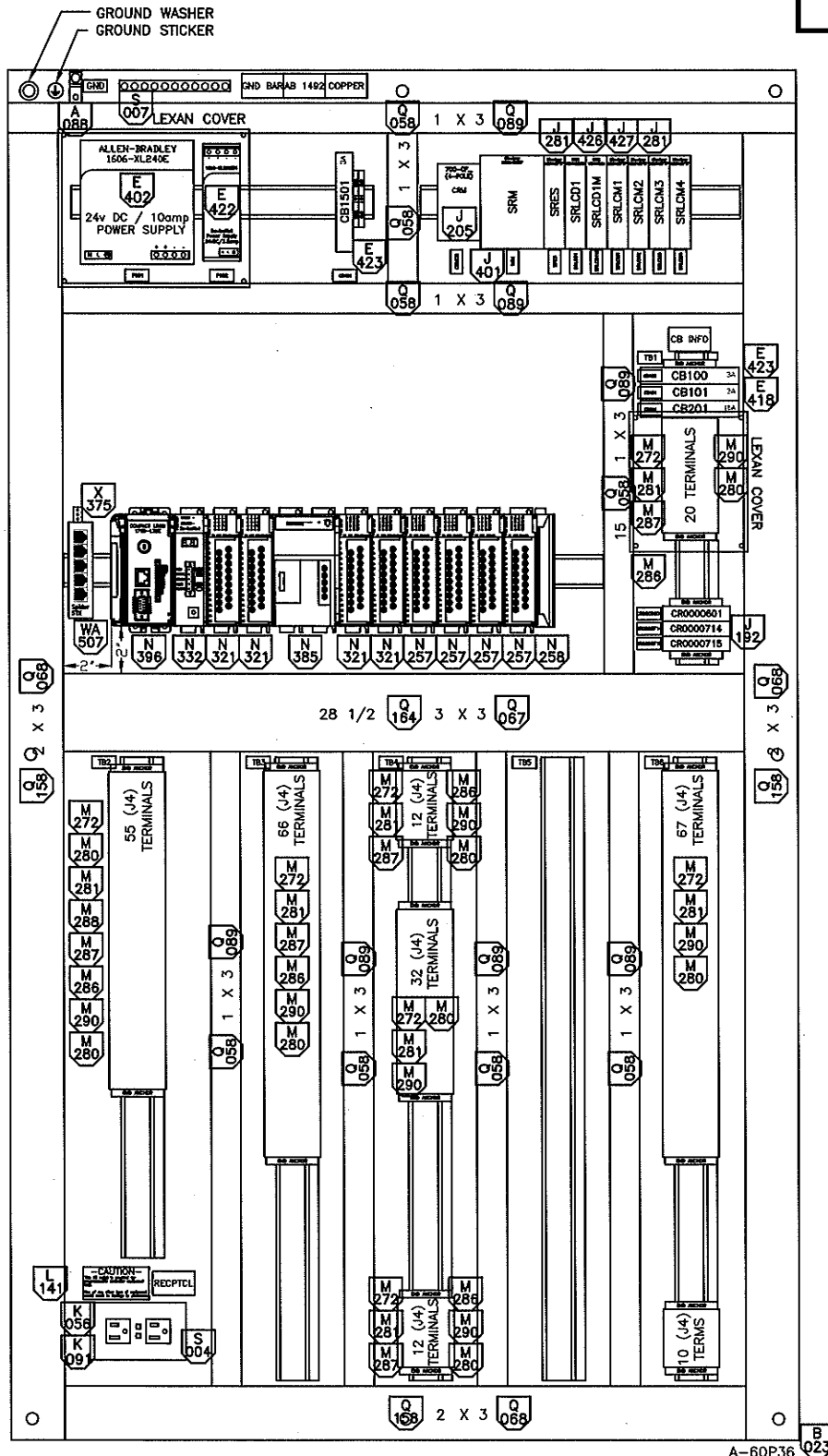

NOTE:
 ALL PANEL WIRING TO ENTER TERMINAL STRIPS ON LEFT SIDE
 AND TERMINAL LABELS ARE TO BE ON THE RIGHT SIDE OF THE TERMINALS

| | | | | | | | | | |
|-----|------|-------------|----|----------|---|-------------|----------------|------|---------|
| REV | DATE | DESCRIPTION | BY | CUSTOMER | DIAGEO NORTH AMERICA INC. RELAY, MD. | BY | HEDDERICH | DATE | 1/13/10 |
| | | | | TITLE | PLC CONTROL PANEL LAYOUT | DWG NO. | EK228L01EN000A | SHT | 009 |
| | | | | | | DRAWING NO. | EK228L01EN/009 | | |



DO NOT SCALE
 UNLESS OTHERWISE SPECIFIED
 TOLERANCES ARE:
 FRACTIONS: ± 1/32"
 DECIMALS:
 .XX ± .03"
 .XXX ± .010"
 ANGLES ± 1'
 CONCENTRICITY: .015" TIR

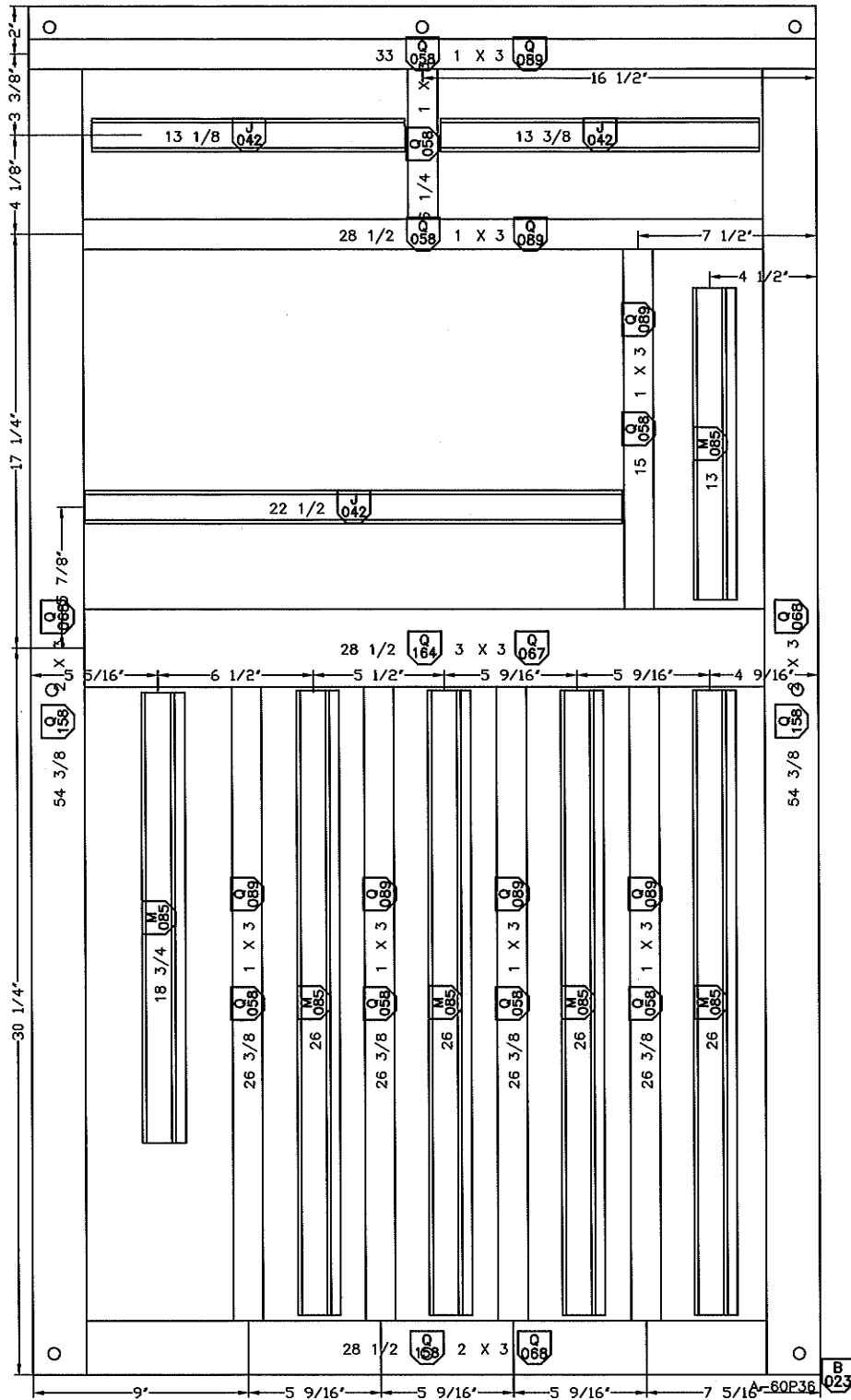

| | | | | | | | | | |
|-----|------|-------------|----|--|---|-------------|----------------------------|---------|----------------|
| REV | DATE | DESCRIPTION | BY | | CUSTOMER DIAGEO NORTH AMERICA INC. RELAY, MD. | BY | HEDDERICH | DATE | 1/13/10 |
| | | | | | | TITLE | PLC CONTROL PANEL TEMPLATE | CAD NO. | EK228L01EN000A |
| | | | | | | DRAWING NO. | EK228L01EN/010 | | |

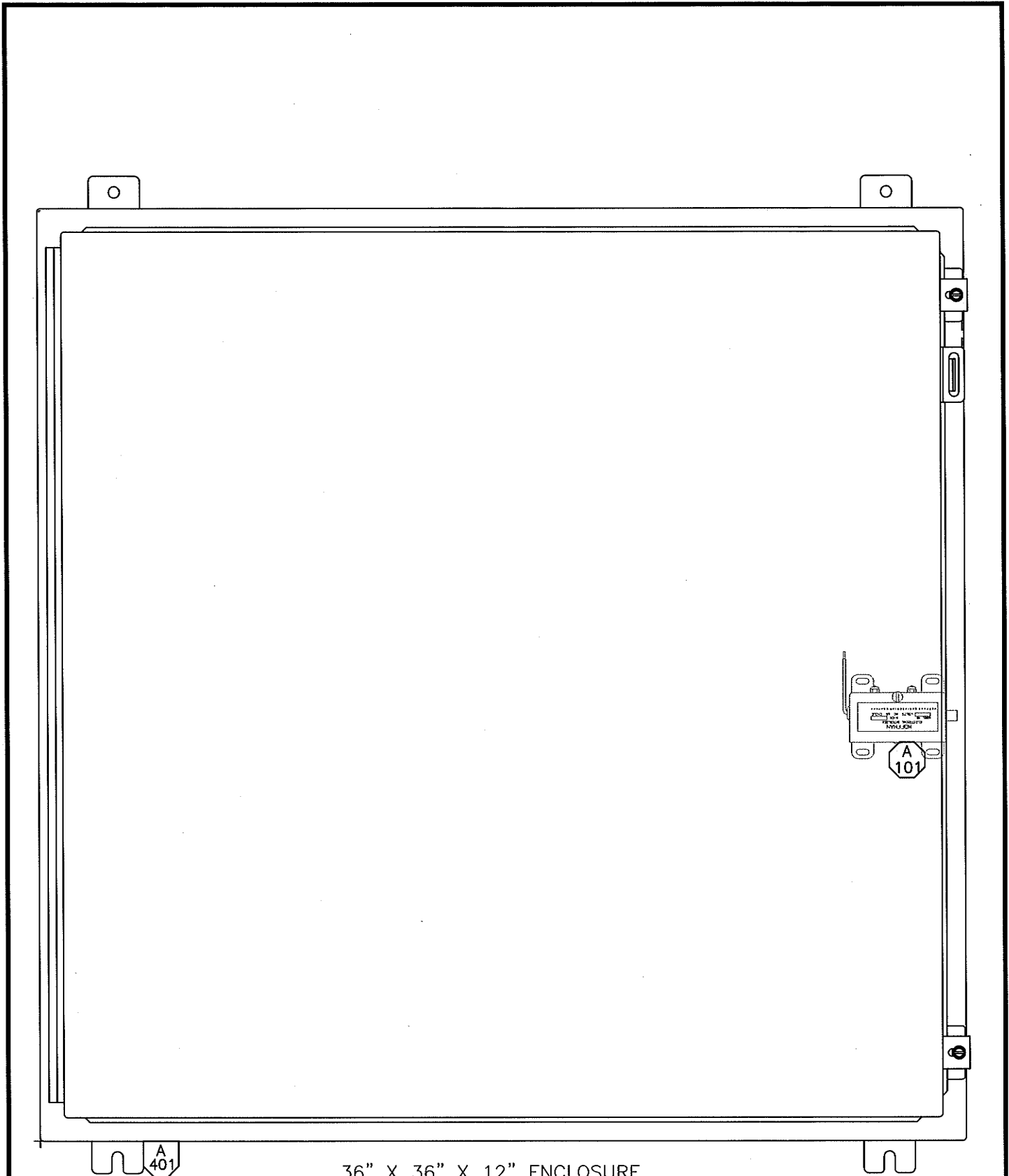

A
401

36" X 36" X 12" ENCLOSURE

| | | | | | | | | |
|-----|------|---|-------------|---|-------------|----------------|------|---------|
| | |  | CUSTOMER | DIAGEO NORTH AMERICA INC. RELAY, MD. | BY | HEDDERICH | DATE | 1/13/10 |
| REV | DATE | | DESCRIPTION | BY | | | | |
| | | | TITLE | BRAKE CONTROL ENCLOSURE | DRAWING NO. | EK228L01EN/014 | | |
| | | | | | CAD NO. | EK228L01EN000A | SHT | 014 |

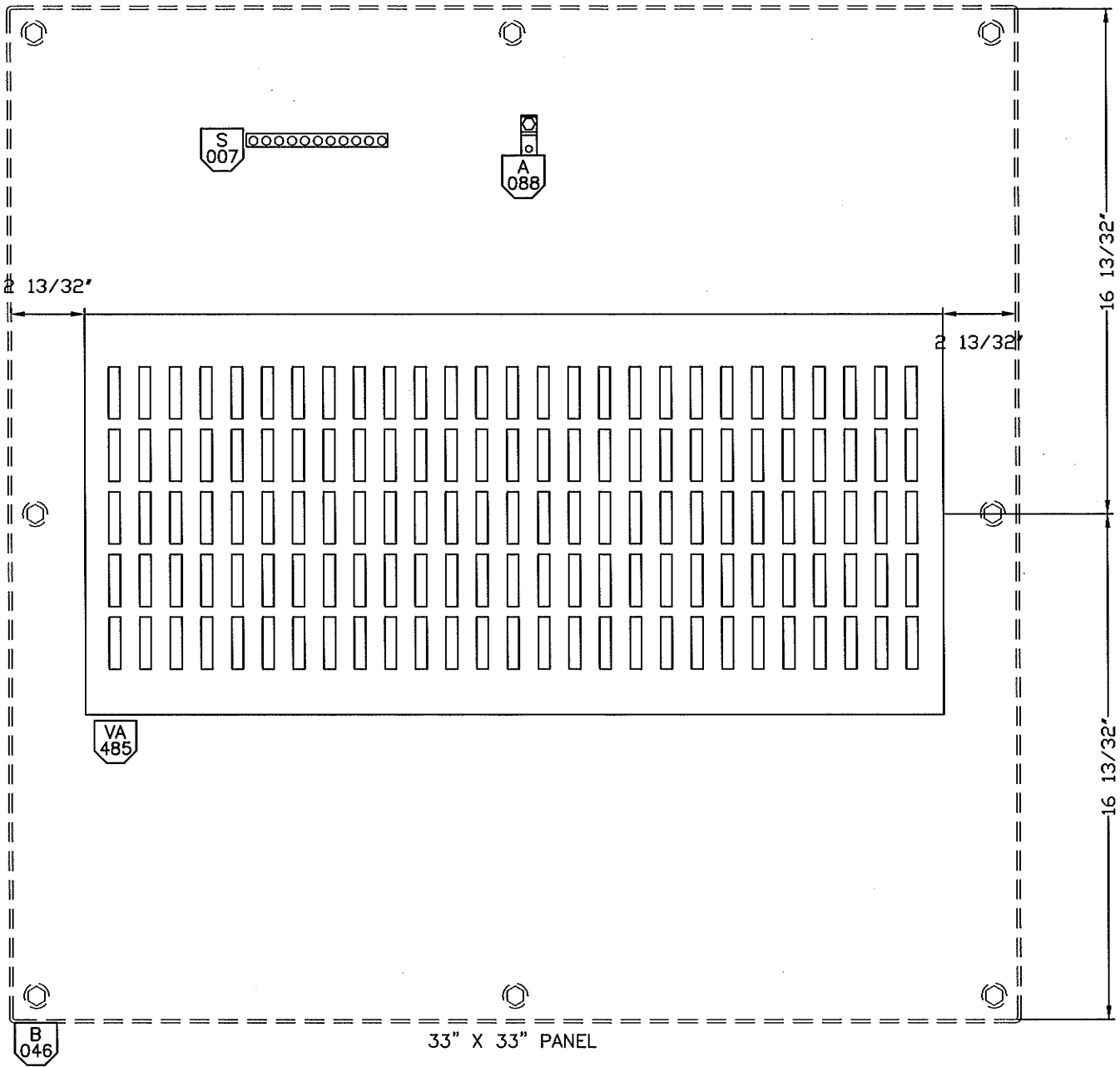

| | | | | | | | | | |
|-----|------|-------------|----|--|---|----------------------------|----------------|-------------|----------------|
| REV | DATE | DESCRIPTION | BY | | CUSTOMER DIAGEO NORTH AMERICA INC. RELAY, MD. | BY | HEDDERICH | DATE | 1/13/10 |
| | | | | | | DRAWING NO. | EK228L01EN/015 | SHT | 015 |
| | | | | | TITLE | DYNAMIC BRAKE PANEL LAYOUT | | DRAWING NO. | EK228L01EN/015 |

8,6 [217,4]

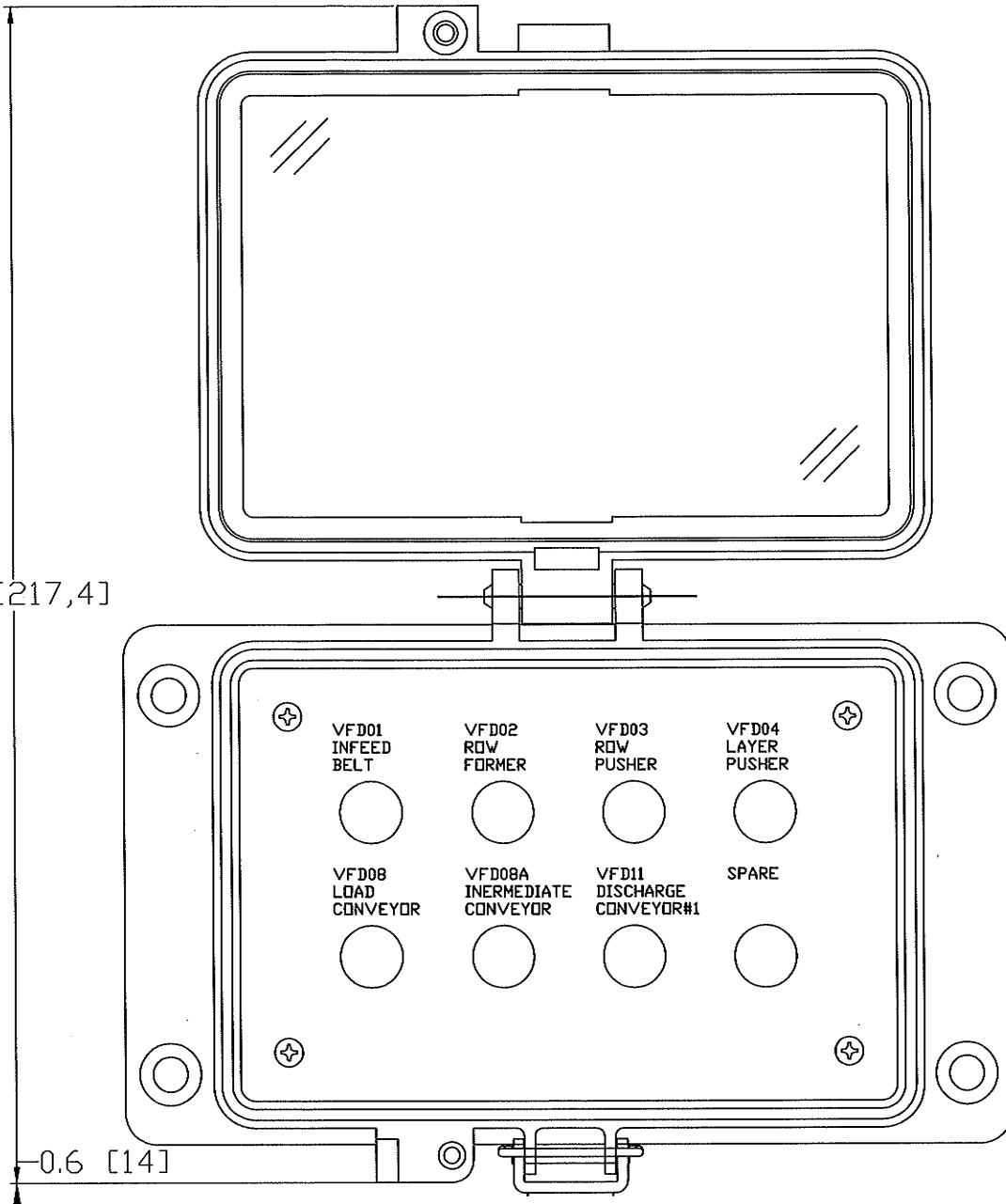

0,6 [14]

| | | | | | | | |
|-----|------|-------------|----|---|---|-------------------------------|-----------------|
| REV | DATE | DESCRIPTION | BY |  | CUSTOMER DIAGEO NORTH AMERICA INC. RELAY, MD. | BY HEDDERICH | DATE 1/13/10 |
| | | | | | TITLE GRACE CONNECTOR LAYOUT | CAD NO. EK228L01EN000A | SIT 016 |
| | | | | | | DRAWING NO. EK228L01EN/016 | |

| | |
|----------------------------------|--|
| WARNING Read Manual... | ADVERTENCIA Favor de leer el manual... |
|----------------------------------|--|

ANSI Z535-2002

L 158

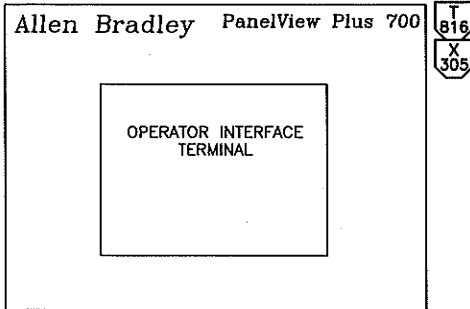

T 816
X 305

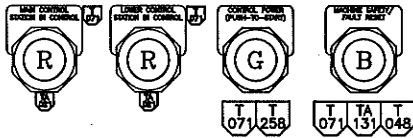

A 156

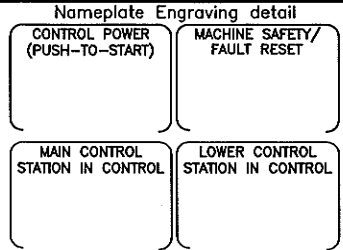

Use these blocks for E-Net connections

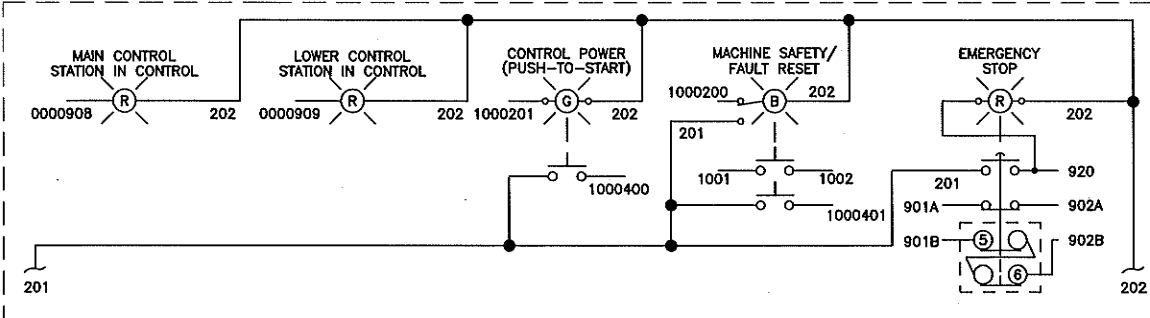
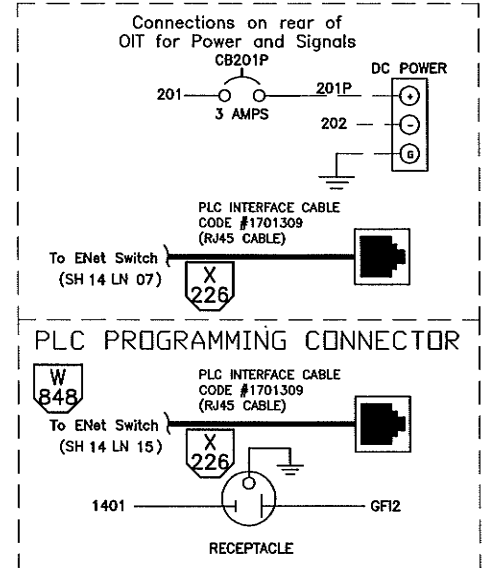

MAIN CONTROL STATION TERMINAL STRIP

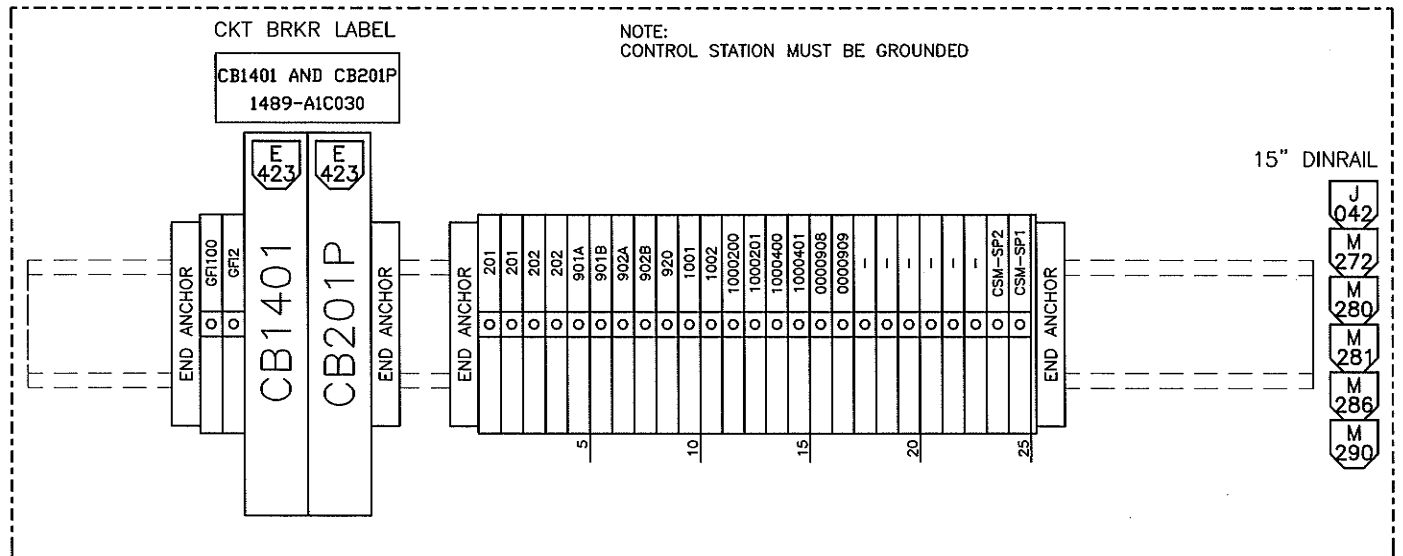

| | | | | | | | | | |
|-----|------|-------------|----|---|---|-------------------------------|-----------------|---------------------------|------------|
| REV | DATE | DESCRIPTION | BY | | CUSTOMER DIAGEO NORTH AMERICA INC. RELAY, MD. | BY HEDDERICH | DATE 1/13/10 | CAD NO. EK228L01CS000A | SHF 001 |
| | | | | TITLE MAIN CONTROL STATION LAYOUT AND WIRING | | DRAWING NO. EK228L01CS/001 | | | |

NOTE: HINGE AT TOP OF CONSOLET

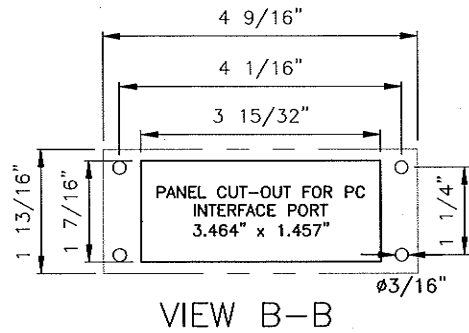
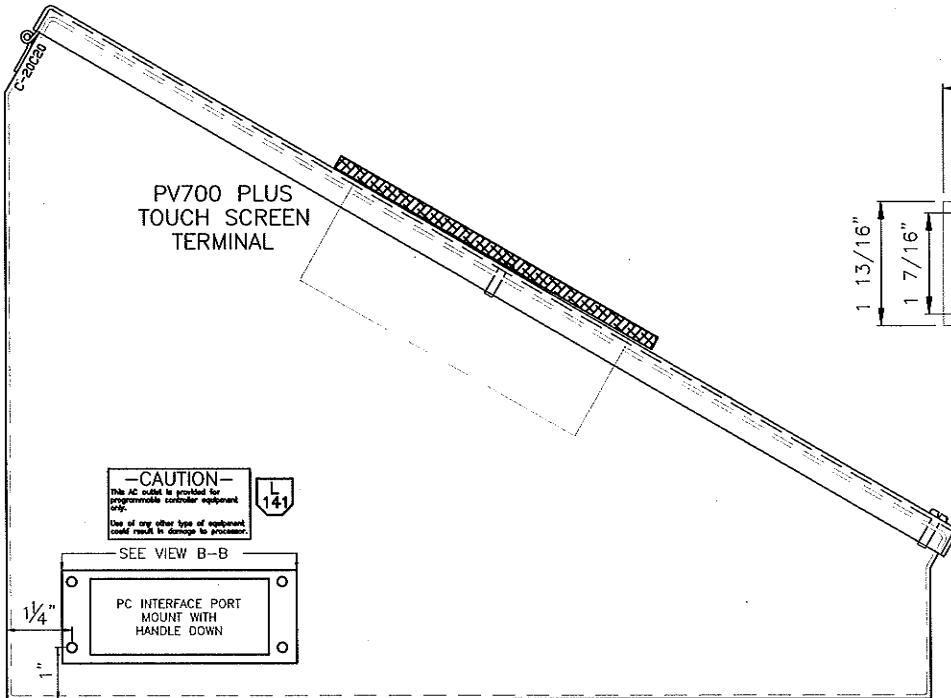
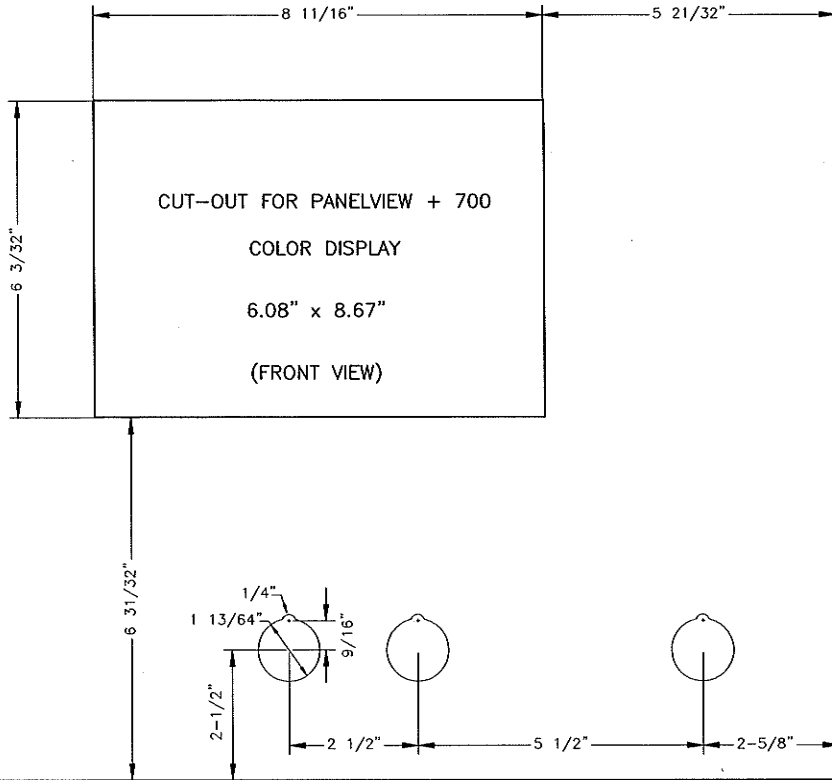

LEFT SIDE VIEW

| | | | | | | | |
|-----|------|-------------|----|---|---|-----------------|-----------------|
| REV | DATE | DESCRIPTION | BY | | CUSTOMER DIAGEO NORTH AMERICA INC. RELAY, MD. | BY HEDDERICH | DATE 1/13/10 |
| | | | | | | | |
| | | | | TITLE MAIN CONTROL STATION DIMENSIONS (10F2) | DRAWING NO. EK228L01CS/002 | | |

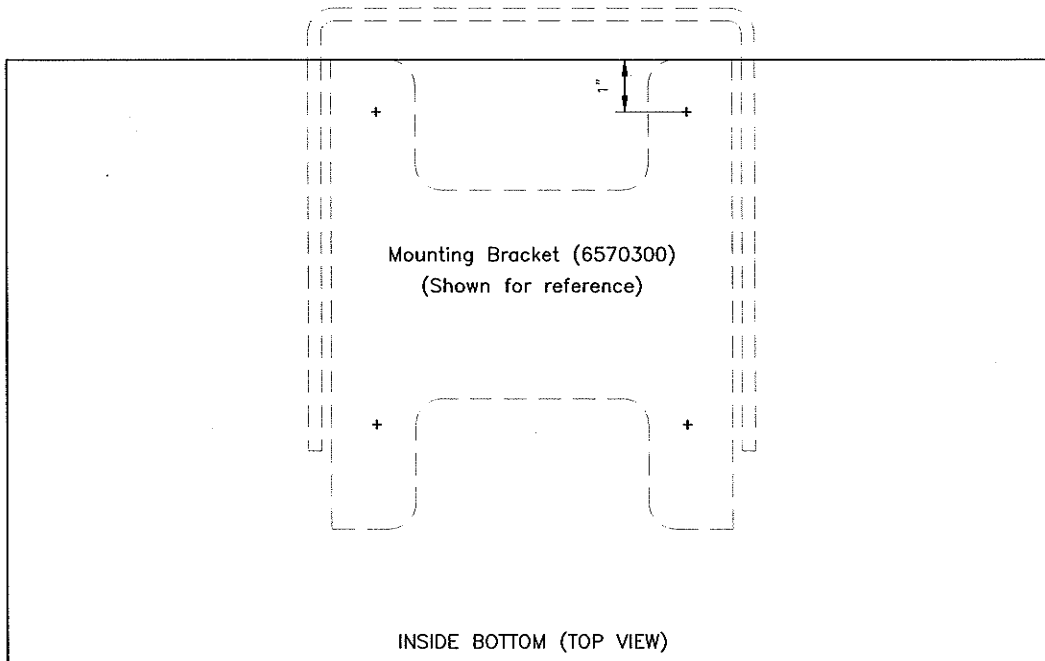
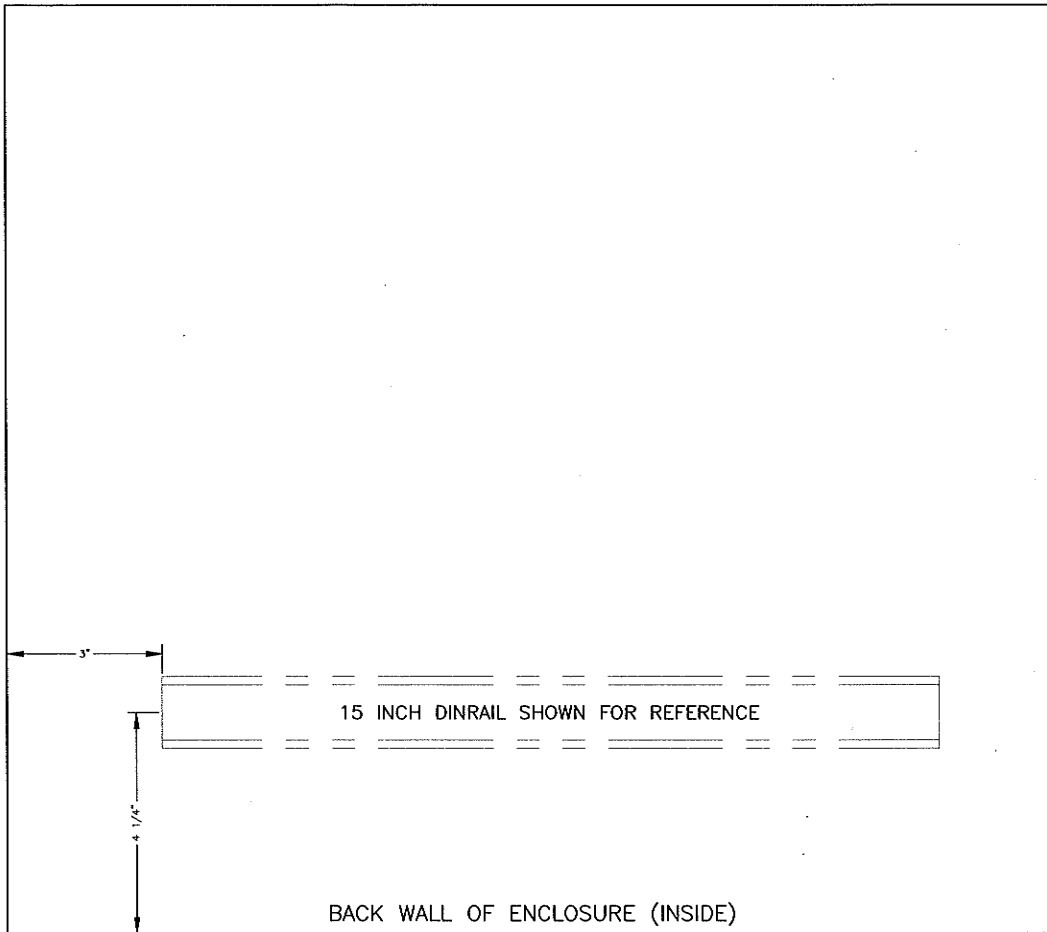

FRONT

| | | | | | | | | | | | |
|-----|------|-------------|--|---|--|---|-------------------------------|--|--|-------------------------|--|
| | | | |  | | CUSTOMER DIAGEO NORTH AMERICA INC. RELAY, MD. | | BY HEDDERICH CAD NO. EK228L01CS000A | | DATE 1/13/10 SHF 003 | |
| REV | DATE | DESCRIPTION | | BY | TYPE MAIN CONTROL STATION DIMENSIONS (20F2) | | DRAWING NO. EK228L01CS/003 | | | | |

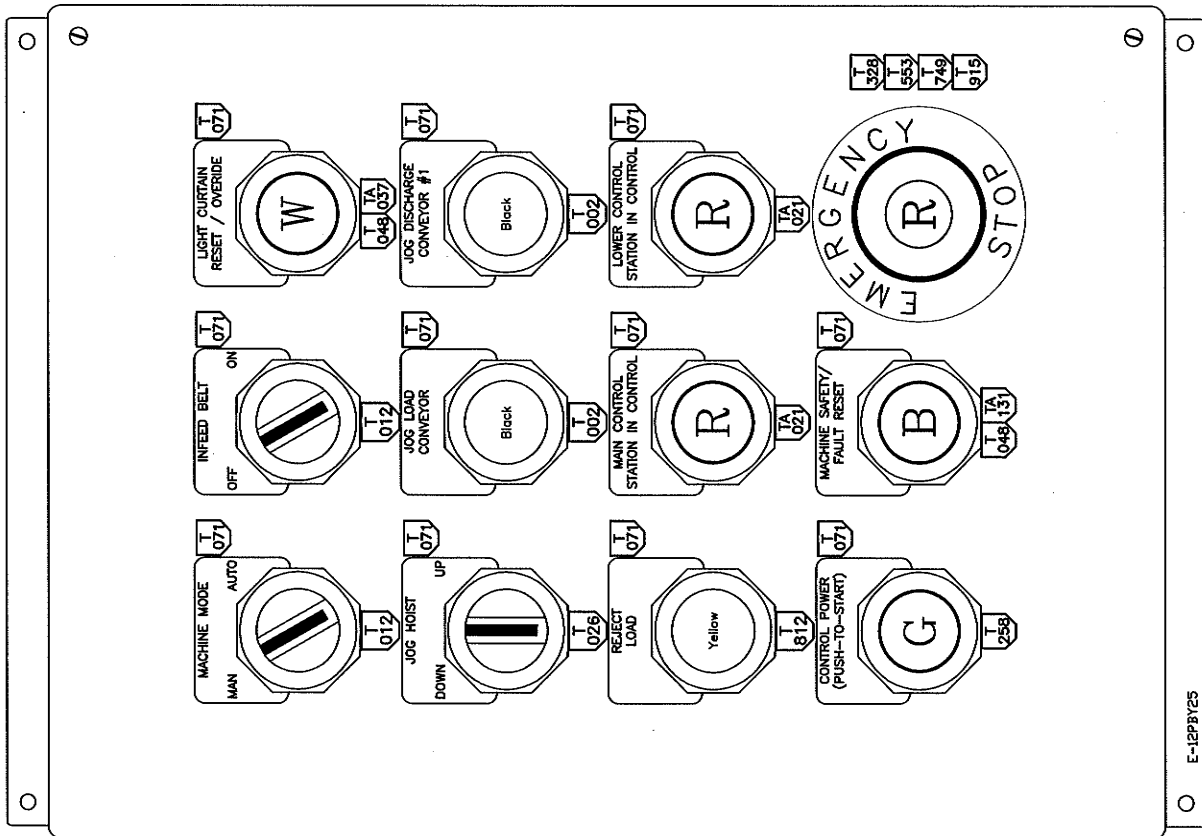
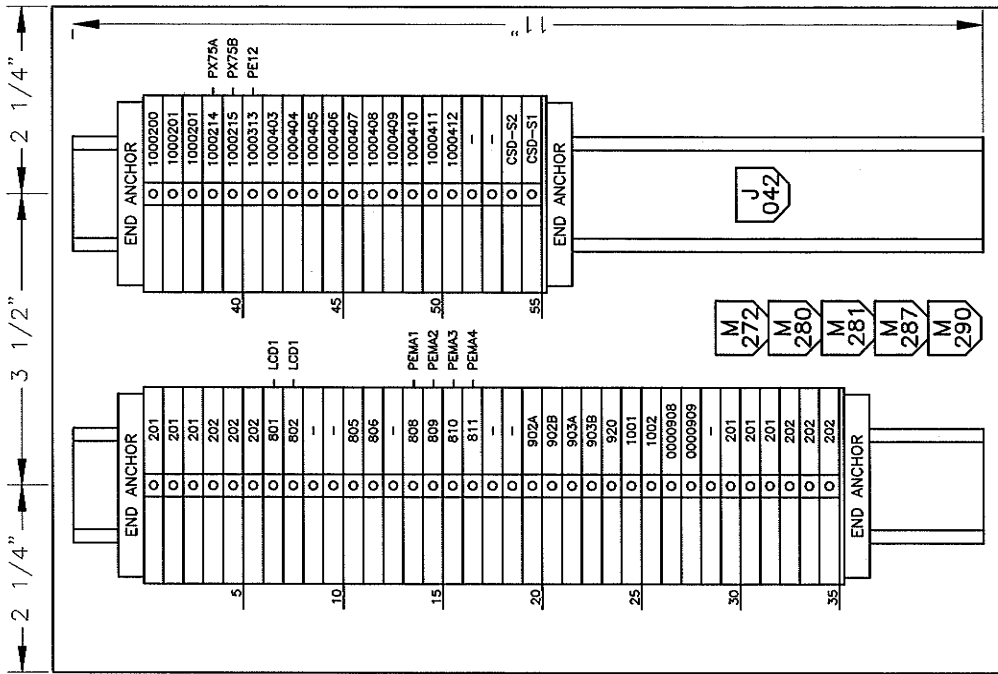

| | | | | | | | | | |
|-----|------|-------------|----|----------|---|-------------|----------------|------|---------|
| REV | DATE | DESCRIPTION | BY | CUSTOMER | DIAGEO NORTH AMERICA INC. RELAY, MD. | BY | HEDDERICH | DATE | 1/13/10 |
| | | | | TITLE | DISCHARGE CONTROL STATION LAYOUT | CAD NO. | EK228L01CS000A | SHT | 004 |
| | | | | | | DRAWING NO. | EK228L01CS/004 | | |



A 055

E-12PB/25

CSD WIRING DIAGRAM

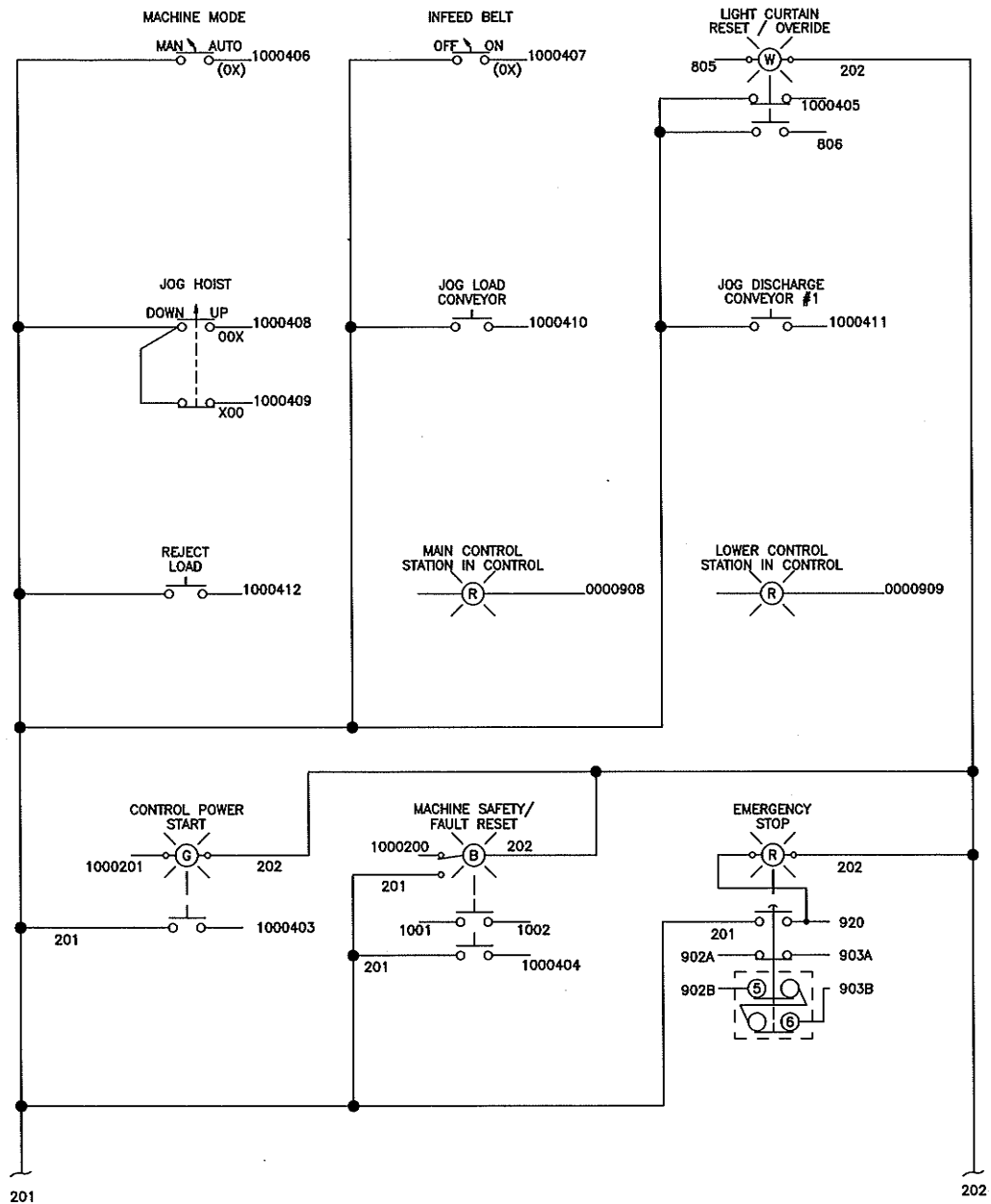

| | | | | | | | | |
|-----|------|-------------|---|--|--|--|---|--|
| | | | | | | | | |
| | | |  | | CUSTOMER DIAGEO NORTH AMERICA INC. RELAY, MD. | | BY HEDDERICH DATE 1/13/10 | |
| | | | | | CAD NO. EK228L01CS000A | | SHEET 005 | |
| | | | TITLE DISCHARGE CONTROL STATION WIRING | | DRAWING NO. EK228L01CS/005 | | | |
| REV | DATE | DESCRIPTION | BY | | | | | |

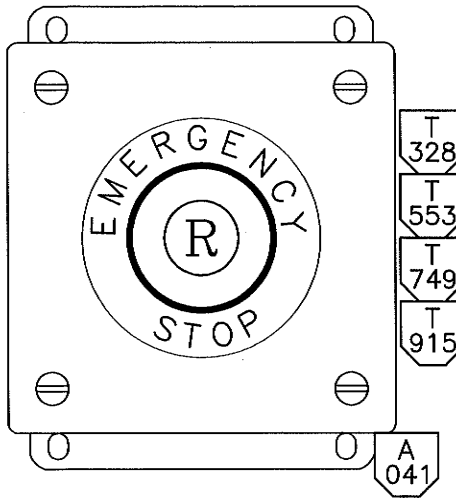

(CSDA)
EMERGENCY STOP STATION (24v DC)

EMERGENCY STOP STATION (24v DC)

WIRING DIAGRAM FOR E-STOP STATION A (CSDA)
(MOUNTED ON MACHINE AT DISCHARGE)
(See Mechanical layout for location)

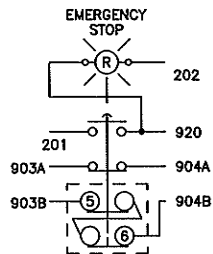

| | | | | | | | | | | |
|-----|------|-------------|----|--|----------|---|-------------|----------------|------|---------|
| REV | DATE | DESCRIPTION | BY | | CUSTOMER | DIAGEO NORTH AMERICA INC. RELAY, MD. | BY | HEDDERICH | DATE | 1/13/10 |
| | | | | | TITLE | DISCHARGE E-STOP STATION A | DRAWING NO. | EK228L01CS/006 | SHT | 006 |

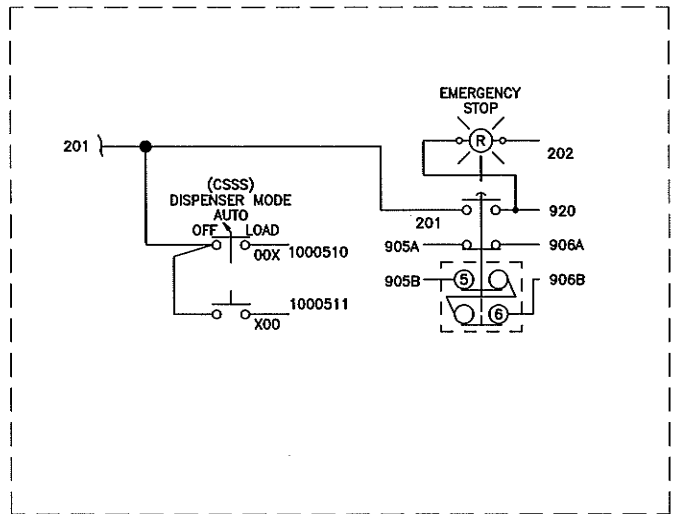
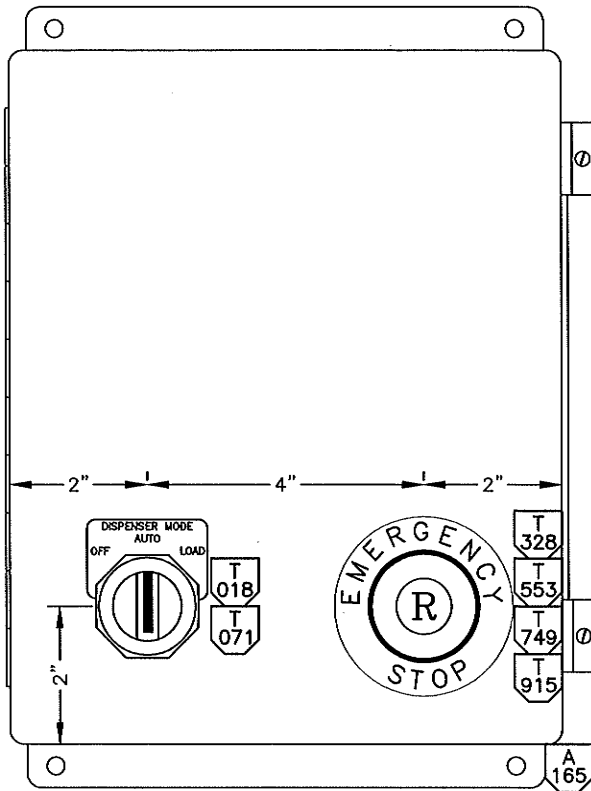

(CSSS)
BASE SHEET DISPENSER CONTROL STATION (24v DC)

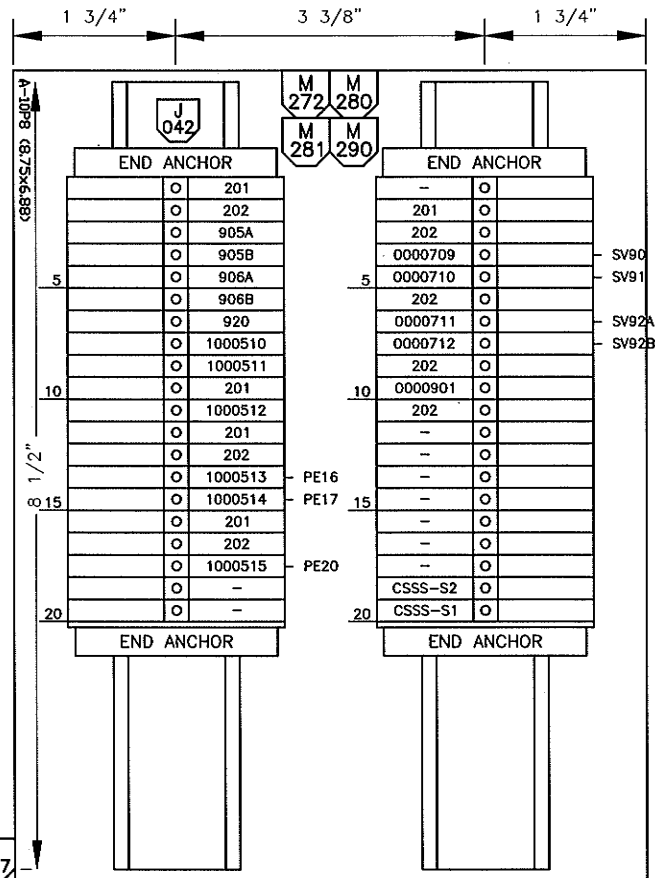

TERMINAL
LISTING

| | | | | | | | | | |
|-----|------|-------------|----|----------|---|-------------|----------------|---------|----------------|
| REV | DATE | DESCRIPTION | BY | CUSTOMER | DIAGEO NORTH AMERICA INC. RELAY, MD. | BY | HEDDERICH | DATE | 1/13/10 |
| | | | | | | | | CAD NO. | EK228L01CS000A |
| | | | | | | | | SHT | 008 |
| | | | | TITLE | SLIPSHEET DISPENSER CONTROL STATION | DRAWING NO. | EK228L01CS/007 | | |



EK228L01BM001 Bill of Materials



Job No: EK228

Sag: 401

Customer: DIAGEO NORTH AMERICA INC.

Address: RELAY,MD.

Created By: SHedderich

Create Date: 1/13/2010 2:42:00 PM

| REV | CODE # | QTY | MARK | DESCRIPTION | MANUFACTURER | MANUFACTURER PART # | SEG |
|-----|---------|-----|-------|--------------------------------|----------------|---------------------|-------|
| | 8100370 | 1 | A088 | ENCL ACCS GND LUG 4-14AWG | BURNDY | KPA4CTP | |
| | 8100378 | 1 | A204 | ENCL ACCS GND LUG 2-8AWG | IDEAL | 87-703 | |
| | 8100036 | 1 | B010 | PNL ENCL PLN 56X56 | HOFFMAN | A-60P60 | |
| | 1708092 | 1 | C012 | DISC FLG FU NEMA12 100A | ALLEN-BRADLEY | 1494V-DH611 | |
| | 1708022 | 1 | C024 | DISC ACCS CONN KT 100A | ALLEN-BRADLEY | 1494R-N2 | |
| | 1702935 | 1 | DU077 | XFMR INT 240/480 120V 1KVA | SOLA | E1000 ASSY | |
| | 1704655 | 1 | E418 | CB 1P 480VAC 10A | ALLEN-BRADLEY | 1489-A1C100 | |
| | 1704936 | 1 | E436 | DIST BLCK 460A 3P 2LINE/6LOAD | FERRAZ SHAWMUT | | 66543 |
| | 1704937 | 3 | E437 | DIST BLCK ACCS CVR | FERRAZ SHAWMUT | | 8570 |
| | 1700769 | 1 | F037 | FB 2P CLS CC 600V 30A | ALLEN-BRADLEY | 1492-FB2C30 | |
| | 1701384 | 9 | F041 | FB 3P CLS CC 600V 30A | ALLEN-BRADLEY | 1492-FB3C30 | |
| | 1713039 | 21 | G116 | FU TD CLS CC 600V 15A | BUSSMANN | LP-CC-15 | |
| | 1713043 | 6 | G119 | FU TD CLS CC 600V 30A | BUSSMANN | LP-CC-30 | |
| | 1713075 | 3 | G138 | FU TD CLS J 600V 100A | BUSSMANN | LPJ-100SP | |
| | 1700234 | 2 | G286 | FU TD CLS CC 600V 4A | BUSSMANN | FNQ-R-4 | |
| | 1790595 | 1 | H030 | STR ACCS AUX CON 1NO | ALLEN-BRADLEY | 595-A | |
| | 1700830 | 1 | H203 | STR ACCS SSUP | ALLEN-BRADLEY | 100-FSV136 | |
| | 1500036 | 3 | H262 | STR IEC ACCS INTF 24VDC | ALLEN-BRADLEY | 100-JE | |
| | 1500134 | 1 | H351 | CON IEC 120V REV 23A 1NO 1NC | ALLEN-BRADLEY | 104-C23UD22 | |
| | 1500056 | 1 | H358 | CON IEC 120V 1WAY 23A 1NO | ALLEN-BRADLEY | 100-C23UD10 | |
| | 1500138 | 2 | H361 | MTR PRTC ACCS AUX CON 1NO | ALLEN-BRADLEY | 140M-C-AFA10 | |
| | 1500139 | 1 | H364 | MTR PRTC 1.0-1.6A | ALLEN-BRADLEY | 140M-C2E-B16 | |
| | 1500141 | 1 | H370 | MTR PRTC 2.5-4.0A | ALLEN-BRADLEY | 140M-D8E-B40 | |
| | 1500147 | 1 | H386 | MTR PRTC ACCS COM LNK TERM | ALLEN-BRADLEY | 140M-C-WT | |
| | 1500148 | 1 | H389 | MTR PRTC ACCS COM LNK JMPR | ALLEN-BRADLEY | 140M-C-WD542 | |
| | 1500149 | 1 | H392 | MTR PRTC ACCS COM LNK 2 UNIT | ALLEN-BRADLEY | 140M-C-W452 | |
| | 1500362 | 1 | H610 | CON SFTY 120V 1WAY 37A | ALLEN-BRADLEY | 100S-C37D14C | |
| | 1500434 | 2 | H664 | CON SFTY 24VDC 1WAY 37A | ALLEN-BRADLEY | 100S-C37DJ14C | |
| | 1709057 | 4 | J042 | DIN RAIL 35MMX15MMX1M | ALLEN-BRADLEY | 199-DR1 | |
| | 1700162 | 3 | M085 | DIN RAIL ELEV 35MMX7.5MMX1M | ALLEN-BRADLEY | 1492-DR6 | |
| | 1703880 | 50 | M272 | TERM BLCK 600V 35A 22-10 AWG | ALLEN-BRADLEY | 1492-J4 | |
| | 1703894 | 4 | M280 | TERM ACCS END ANCH J TERM | ALLEN-BRADLEY | 1492-EAJ35 | |
| | 1703895 | 4 | M281 | TERM ACCS END BARR GRAY J TERM | ALLEN-BRADLEY | 1492-EBJ3 | |
| | 1703900 | 3 | M286 | TERM ACCS JMP CNTR 2P J4 | ALLEN-BRADLEY | 1492-CJJ6-2 | |
| | 1703901 | 5 | M287 | TERM ACCS JMP CNTR 3P J4 | ALLEN-BRADLEY | 1492-CJJ6-3 | |
| | 1703902 | 1 | M288 | TERM ACCS JMP CNTR 10P J4 | ALLEN-BRADLEY | 1492-CJJ6-10 | |

Doc. Name: EK228L01BM001

Description: MCP Bill of Material

Print Date: 4/26/2010 Print Time: 2:21 PM

EK228L01BM001 Bill of Materials



Created By: SHedderich
Create Date: 1/13/2010 2:42:00 PM

Job No: EK228
Seg: 401
Customer: DIAGEO NORTH AMERICA INC.
Address: RELAY,MD.

| REV | CODE # | QTY | MARK | DESCRIPTION | MANUFACTURER | MANUFACTURER PART # | SEG |
|-------------------------|---------|-----|-------|--------------------------------|-----------------|---------------------|---------|
| | 1703904 | 1 | M290 | TERM ACCS MKR CARD OF 120 J4 | ALLEN-BRADLEY | 1492-MR6X12 | |
| | 1700553 | 5 | Q058 | WDCT 1X3X6 LT GRY | THOMAS & BETTS | TY1X3WPG6 | |
| | 1700555 | 5 | Q068 | WDCT ACCS CVR 2X6 LT GRY | THOMAS & BETTS | TY2CPG6 | |
| | 1701716 | 5 | Q089 | WDCT ACCS CVR 1X6 LT GRY | THOMAS & BETTS | TY1CPG6 | |
| | 1705216 | 5 | Q158 | WDCT 2X3X6 GRY | THOMAS & BETTS | TY2X3WPG6 | |
| | 1709457 | 2 | S007 | TERM ACCS GND BAR 8HL CPPR | BLACKBURN | WGB8B | |
| | 8100608 | 8 | S097 | CONN DNET DBL ENDED | PHOENIX CONTACT | | 1853201 |
| | 1702079 | 1 | V907 | PFLEX VFD NEMA1 480V 15 HP | ALLEN-BRADLEY | 20AD027A0AYNANC0 | |
| | 1702080 | 1 | V908 | VFD ACCS INTF MOD DVN | ALLEN-BRADLEY | 20-COMM-D | |
| | 1702081 | 1 | V909 | VFD ACCS HIM | ALLEN-BRADLEY | 20-HIM-A3 | |
| | 1702900 | 7 | VA057 | VFD ACCS PWRFLX40 INTF MOD DVN | ALLEN-BRADLEY | 22-COMM-D | |
| | 1702901 | 7 | VA058 | VFD ACCS PWRFLX40 COMM CVR | ALLEN-BRADLEY | 22B-CCB | |
| | 1704209 | 8 | VA230 | VFD ACCS MOD SAFE OFF | ALLEN-BRADLEY | 20A-DG01 | |
| | 9252837 | 1 | VA386 | MNT PLT POWERFLEX 40 2 STN | | | |
| | 9252841 | 2 | VA387 | MNT PLT POWERFLEX 40 3 STN | | | |
| | 9252855 | 5 | VA390 | STAND-OFF POWERFLEX 40 | | | |
| | 1705438 | 7 | VA450 | VFD PFLEX 40P 460V 3HP | ALLEN BRADLEY | 22D-D6PON104 | |
| | 2750048 | 75 | W609 | CBL DVN DROP | ALLEN-BRADLEY | 1485C-P1-C150 | |
| Revision History | | | | | | | |
| Rev | Date | | | Description | By | | |

EK228L01BM002 Bill of Materials



Created By: Shehderich
Create Date: 1/13/2010 2:43:00 PM

Job No: EK228
Seg: 401
Customer: DIAGEO NORTH AMERICA INC.
Address: RELAY,MD.

| REV | CODE # | QTY | MARK | DESCRIPTION | MANUFACTURER | MANUFACTURER PART # | SEG |
|-----|---------|-----|------|--------------------------------|----------------|---------------------|-----|
| | 8100370 | 1 | A088 | ENCL ACCS GND LUG 4-14AWG | BURNDY | KPA4CTP | |
| | 8101020 | 1 | B023 | PNL ENCL PLN 57X33 | HOFFMAN | A-60P36 | |
| | 1704383 | 1 | E402 | PWRS INT 120V 24VDC 10A | ALLEN-BRADLEY | 1606-XL240E | |
| | 1704655 | 1 | E418 | CB 1P 480VAC 10A | ALLEN-BRADLEY | 1489-A1C100 | |
| | 1704726 | 1 | E422 | PWRS INT 120V 24VDC 3.8A | ALLEN-BRADLEY | 1606-XLSDNET4 | |
| | 1704744 | 3 | E423 | CB 1P 480VAC 3A | ALLEN-BRADLEY | 1489-A1C030 | |
| | 1709057 | 4 | J042 | DIN RAIL 35MMX15MMX1M | ALLEN-BRADLEY | 199-DR1 | |
| | 1700732 | 3 | J192 | RLY FXD 24VDC 10A SPST ASSY | ALLEN-BRADLEY | 700-NX80 | |
| | 1700563 | 1 | J205 | RLY FXD 24VDC 14A 4NO | ALLEN-BRADLEY | 700-CF400ZJ | |
| | 1702528 | 5 | J281 | RLY SFTY 24VDC | ALLEN-BRADLEY | 440R-N23132 | |
| | 1704709 | 1 | J401 | SFTY MNTR RLY 24V AC/DC | ALLEN-BRADLEY | 440R-G23216 | |
| | 1705556 | 1 | J426 | RLY SFTY LGHT CRTN MUTE 24VDC | SICK | 6034482 | |
| | 1705557 | 1 | J427 | RLY SFTY 24VDC OTPT MOD | SICK | 6026144 | |
| | 8102421 | 1 | K056 | OTLT BOX 4X2-1/8X1-7/8 | STEEL CITY | 58361-1/2 | |
| | 1702620 | 1 | K091 | RCPT DPLX GF1 120V 15A GRY | HUBBELL | SGF15GYLA | |
| | 9000120 | 1 | L141 | SIGN CAUTN THIS AC OTLT IS PRO | | | |
| | 1700162 | 3 | M085 | DIN RAIL ELEV 35MMX7.5MMX1M | ALLEN-BRADLEY | 1492-DR6 | |
| | 1703880 | 255 | M272 | TERM BLCK 600V 35A 22-10 AWG | ALLEN-BRADLEY | 1492-J4 | |
| | 1703894 | 18 | M280 | TERM ACCS END ANCH J TERM | ALLEN-BRADLEY | 1492-EAJ35 | |
| | 1703895 | 8 | M281 | TERM ACCS END BARR GRAY J TERM | ALLEN-BRADLEY | 1492-EBJ3 | |
| | 1703900 | 6 | M286 | TERM ACCS JMP CNTR 2P J4 | ALLEN-BRADLEY | 1492-CJJ6-2 | |
| | 1703901 | 10 | M287 | TERM ACCS JMP CNTR 3P J4 | ALLEN-BRADLEY | 1492-CJJ6-3 | |
| | 1703902 | 2 | M288 | TERM ACCS JMP CNTR 10P J4 | ALLEN-BRADLEY | 1492-CJJ6-10 | |
| | 1703904 | 3 | M290 | TERM ACCS MKR CARD OF 120 J4 | ALLEN-BRADLEY | 1492-MR6X12 | |
| | 1701645 | 4 | N257 | MICRO OTP 16 PT 24 VDC | ALLEN-BRADLEY | 1769-OB16 | |
| | 1701646 | 1 | N258 | MICRO EXP END CAP | ALLEN-BRADLEY | 1769-ECR | |
| | 1702159 | 4 | N321 | MICRO INP MOD 16PT 24 VDC | ALLEN-BRADLEY | 1769-IQ16 | |
| | 1702302 | 1 | N332 | MICRO DVN SCNR MOD | ALLEN-BRADLEY | 1769-SDN | |
| | 1703008 | 1 | N385 | PWRS CMP I/O 4A | ALLEN-BRADLEY | 1769-PA4 | |
| | 1703219 | 1 | N396 | PLC CPU COMPACT LOGIX L32E | ALLEN-BRADLEY | 1769-L32E | |
| | 1700553 | 6 | Q058 | WDCT 1X3X6 LT GRY | THOMAS & BETTS | TY1X3WPG6 | |
| | 1700671 | 1 | Q067 | WDUCT ACCS CVR 3X6 LT GRAY | THOMAS & BETTS | TY3CPG6 | |
| | 1700555 | 3 | Q068 | WDCT ACCS CVR 2X6 LT GRY | THOMAS & BETTS | TY2CPG6 | |
| | 1701716 | 6 | Q089 | WDCT ACCS CVR 1X6 LT GRY | THOMAS & BETTS | TY1CPG6 | |
| | 1705216 | 3 | Q158 | WDCT 2X3X6 GRY | THOMAS & BETTS | TY2X3WPG6 | |
| | 1705212 | 1 | Q164 | WDCT 3X3X6 GRY | THOMAS & BETTS | TY3X3WPG6 | |

Doc. Name: EK228L01BM002
Description: PCP Bill of Material

Print Date: 4/26/2010 Print Time: 2:22 PM

