

Nikon

培養倒立顯微鏡

ECLIPSE TS100 / TS100-F

使用說明書

Inverted Microscope

ECLIPSE TS100 / TS100-F

Instructions

Thank you for purchasing the Nikon products.

This instruction manual is written for the users of the Nikon's Inverted Microscope ECLIPSE TS100/TS100-F and describes the basic operations of the microscope. To ensure correct usage, read this manual carefully before operating the instrument.

- It is prohibited to reproduce or transmit this manual in part or whole without Nikon's expressed permission.
- The contents of this manual are subject to change without notice.
- Although every effort has been made to ensure the accuracy of this manual, if you note any points that are unclear or incorrect, contact your nearest Nikon representative.
- Some of the products described in this manual may not be included in the set you have purchased.
- Be sure to read the operation manual for any other products (such as a Epi-fluorescence attachment) used in combination with this microscope.
- HOFFMAN MODULATION CONTRAST SYSTEM[®] is the registered trademark of MODULATION OPTICS Inc.



Contents

Safety Precautions	4
English	4
German	9
French	14
Spanish	19
Italian	24
Dutch	29
Danish	34
Portuguese	39
Finnish	44
Greek	49
Notes on Handling the System	54
I Names of Parts	56
II Names of Operational Parts	57
III Microscopy	58
1 Microscopy	58
2 Phase Contrast Microscopy	60
3 Hoffman Modulation Contrast (HMC) Microscopy	62
4 Bright-field Microscopy	65
IV Operation of Each Part	66
1 Aperture Diaphragm	66
2 Specimen and Stage	67
1) 35-mm petri dishes	67
2) Observing suspended cells	67
3) Using the mechanical stage	67
4) Using large containers	68
3 Focusing Device	68
4 Filters	69
5 Objectives	69
1) Ph codes	69
2) MC codes	69
3) Objectives with correction ring	70
4) Cover glass thickness	70
5) Oil immersion objectives	70
6 Hoffman Modulation Contrast Method	72
1) Hoffman Modulation Contrast System	72
2) Principles of Modulation Contrast	72
7 Photomicrography (TS100-F Only)	74
1) Single lens reflex cameras	74
2) Photomicrographic equipment	75
3) TV cameras and digital cameras	75

V Assembly 76

 1 Assembling the Basic Set..... 76

 2 Assembling Components Not Included in the Basic Set..... 79

VI Troubleshooting 81

VII Care and Maintenance 86



VIII Technical Specifications 87

Safety Precautions

Warning/Caution Symbols Used in This Manual

Although Nikon products are designed to provide you with the utmost safety during use, incorrect usage or disregard of the instructions can cause personal injury or property damage and will lead to the forfeiture of all claims against warranty. For your safety, read the instruction manual carefully and thoroughly before using the instrument. Do not discard this manual but keep it near the product for easy reference.



In this manual, safety instructions are indicated with the symbols shown below. Be sure to follow the instructions indicated with these symbols to ensure correct and safe operation.

Symbol	Meaning
 WARNING	Disregarding instructions marked with this symbol may lead to death or serious injury.
 CAUTION	Disregarding instructions marked with this symbol may lead to injury or property damage.

Meaning of Symbols Used on the Equipment

The symbol appearing on the product indicates the need for caution at all times during use.

Always refer to the instruction manual and read the relevant instructions before manipulating any part to which the symbol has been affixed.

Symbol	Meaning				
	<p>Caution! Biohazard</p> <p>This symbol label attached on the stages reminds you of the following:</p> <ul style="list-style-type: none"> • WARNING: Spillage of a sample from a vessel onto the microscope, presents a biohazard risk. • To avoid biohazard contamination, do not touch the contaminated portion with your bare hands. • Decontaminate the contaminated portion according to the standard procedure of your laboratory. 				
	<p>Caution for heat</p> <p>This symbol label attached on the lamphouse cover reminds you of the following:</p> <ul style="list-style-type: none"> • Lamp and its surrounding areas (including the lamphouse cover) become very hot during and immediately after illumination. • Risk of burns. Do not touch the lamp or surrounding areas during and immediately after illumination. • Make sure the lamp and its surrounding areas have cooled sufficiently before attempting to replace the lamp. 				
	<p>Caution</p> <p>This symbol label attached near the AC inlet reminds you of the following:</p> <ul style="list-style-type: none"> • Check the input voltage before turning on the microscope. (The input voltage is given on the "nameplate" and on immediate right of the AC inlet.) • The voltage selector on the microscope sent to the United States is set to "120V" at the factory. • If the input voltage shown differs from the local voltage level, do not turn on the microscope. <p>Do the following instead:</p> <table border="0" style="width: 100%;"> <tr> <td style="padding-right: 20px;">Different voltage on the nameplate</td> <td>Contact your nearest Nikon representative.</td> </tr> <tr> <td>Different voltage on right of the AC inlet</td> <td>Change the input voltage setting; refer to P.76.</td> </tr> </table>	Different voltage on the nameplate	Contact your nearest Nikon representative.	Different voltage on right of the AC inlet	Change the input voltage setting; refer to P.76.
Different voltage on the nameplate	Contact your nearest Nikon representative.				
Different voltage on right of the AC inlet	Change the input voltage setting; refer to P.76.				

**WARNING****1. Intended use of the equipment**

This microscope is intended mainly for use in microscopic observation and in the micromanipulation of living cells and tissue using diascopic (transmitted) and episcopic (reflected) illumination.

It is designed for the main purposes of experimentation and observation, in hospitals or other laboratories, of such cells and tissue within the fields of genetics, immunology, physiology, pharmacology, neurology, cellular biology, and molecular biology.

2. Do not disassemble.

Disassembly may cause malfunction and/or electrical shock, and will lead to the forfeiture of all claims against warranty. Do not disassemble any part other than those described in this manual. If you experience any problem with the microscope, notify your nearest Nikon representative.

3. Input voltage

Make sure that the input voltage indicated on two places (on the nameplate and on the immediate right of the AC inlet at the microscope's rear) are the same as your local voltage. Do not use the microscope if the local voltage differs from that required by the microscope. Follow the instructions below if this is the case. Use of the microscope under the incorrect voltage may cause over-heating due to over-current, possibly resulting in a fire and damaging the microscope.

- If the voltage indicated on the nameplate differs from local voltage, do not turn on the power but contact your nearest Nikon representative immediately.
- If the voltage indicated to the immediate right of the AC inlet differs from local voltage, change the input voltage setting as described on P.76 before turning on the power. The following values may be set for the input voltage.
 - If the nameplate reads "100/110/120 V ~", the input voltage may be set to 100, 110 or 120 V AC. (Factory setting: 120 V AC)
 - If the nameplate reads "220/230/240 V ~", the input voltage may be set to 220, 230 or 240 V AC. (Factory setting: 240 V AC)

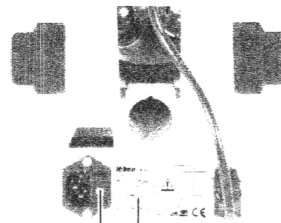

Input voltage indications

**WARNING****4. Use only the specified lamps, fuses and power cord.**

Use only the lamps, fuses and power cord specified. Use of other lamps, fuses or power cord, may result in damage to the microscope or fire. (For details on the power cord, see P.88.)

When using an extension cord, be sure to use one that includes a PE wire (protective earth wire) and be sure it is connected securely.

- Specified lamp: Halogen lamp 6V-30W (PHILIPS 5761)
- Specified fuse: 250V, 1A, time-lag, low-breaking type 5x20 miniature fuse x2

5. Heat from the light source

Do not touch the lamphouse while the lamp is on and for about 30 minutes after it is turned off as it becomes extremely hot.

- Allow the lamp to cool sufficiently (for at least 30 minutes after being turned off) before replacing the lamp.
- To avoid burns, never touch the lamp or its surroundings while the lamp is lit or within 30 minutes after switching off the power.
- To avoid the risk of fire, do not allow cloth, paper, or highly flammable volatile materials, such as gasoline, petroleum benzene, acetone, thinner or alcohol, to come near the lamp or the surrounding area while the lamp is lit or for about thirty minutes after the lamp has been turned off.

6. Hazardous sample

This microscope should mainly be used for microscopic observation and micromanipulation of living cells and tissue cultures in Petri dishes, microtiter plates, etc.

When handling a sample, check to determine whether the sample is hazardous.

Handle hazardous samples according to the standard procedure of your laboratory. If the sample is of an infectious nature, wear rubber gloves to avoid infection, and be careful not to spill the sample. In the event of spillage of a sample from a vessel onto the microscope, decontaminate the contaminated portion according to the standard procedure of your laboratory.

**CAUTION****1. Turn off the power when assembling the microscope, replacing lamps and fuses, and plugging or unplugging the power cord.**

To prevent electrical shock and/or fire, always turn off the power of the microscope (press down the front-half of the power switch) before plugging or unplugging the power cord. Also, always turn off the power of the microscope and unplug the power cord when assembling the microscope, or replacing lamps or fuses.

2. Do not wet the microscope or allow foreign matter to get inside.

If the microscope becomes wet, a short circuit may result that could damage it or make it extremely hot. Similarly, a short may occur if foreign matter gets inside. If you accidentally spill a liquid on the microscope, immediately turn off power to the microscope (press down the front-half of the power switch) and unplug the power cord. (Take care not to touch the cord with wet hands at this time.) After unplugging the microscope, use a dry cloth to wipe away any moisture.

If liquid spills on the water tray, use tissue paper to absorb it from the groove on the left. Then remove the water tray cover using a hexagonal wrench. Wipe dry the inside if there is any moisture. Check if the lamp cable connector or AC inlet on the rear panel are wet, and if so, wipe them dry.

If any liquid or foreign matter gets inside, do not use the microscope, but contact your nearest Nikon representative.

3. Disposal of the microscope

To avoid biohazard risk, dispose of the microscope as the contaminated equipment according to the standard procedure of your laboratory.



ΠΡΟΦΥΛΑΞΗ

- 1. Κλείστε το διακόπτη τροφοδοσίας πριν από συναρμολόγηση του μικροσκοπίου, αντικατάσταση λαμπτήρα ή ασφάλειας καθώς και πριν την εισαγωγή ή εξαγωγή του καλώδιου τροφοδοσίας.**

Κλείστε το διακόπτη τροφοδοσίας (πιέστε προς τα κάτω το εμπρόσθιο ήμισυ του διακόπτη τροφοδοσίας) πριν την εισαγωγή ή εξαγωγή του καλώδιου τροφοδοσίας, για να αποτρέψετε την ηλεκτροπληξία και/ή πυρκαγιά. Επίσης, να κλείνετε πάντα το διακόπτη τροφοδοσίας και να αφαιρείτε το καλώδιο τροφοδοσίας πριν τη συναρμολόγηση του μικροσκοπίου και πριν την αλλαγή του λαμπτήρα ή της ασφάλειας.

- 2. Μην αφήνετε να εισέλθουν στο μικροσκόπιο ξένα στοιχεία ή να βραχεί.**

Αν το μικροσκόπιο πάρει υγρασία υπάρχει κίνδυνος να προκληθεί βραχυκύκλωμα που θα μπορούσε να προκαλέσει ζημιά ή υπερθέρμανση. Παρομοίως, υπάρχει κίνδυνος βραχυκυκλώματος αν εισχωρήσουν ξένα στοιχεία. Αν κατά λάθος πέσει νερό πάνω στο μικροσκόπιο, κλείστε αμέσως το διακόπτη τροφοδοσίας (πιέστε το εμπρόσθιο τμήμα του διακόπτη τροφοδοσίας) και βγάλτε το καλώδιο τροφοδοσίας από την πρίζα. (Φροντίστε να μην αγγίξετε το καλώδιο με υγρά χέρια) Αφού αποσυνδέσετε το καλώδιο τροφοδοσίας, σκουπίστε το μικροσκόπιο με ένα στεγνό πανί.

Αν διαρρεύσει υγρό στο δίσκο νερού, χρησιμοποιήστε μια χαρτοπετσέτα για να το απορροφήσετε από την εγκοπή αριστερά. Στη συνέχεια αφαιρέστε το καπάκι του δίσκου νερού με ένα εξαγωνικό κλειδί. Καθαρίστε και στεγνώστε το εσωτερικό από από την υγρασία. Ελέγξτε αν ο συνδετήρας του καλώδιου του λαμπτήρα ή της εισόδου AC στον πίσω πίνακα είναι υγρά και, σ'αυτήν την περίπτωση, στεγνώστε τα.

Αν εισχωρήσει υγρό ή ξένα στοιχεία στο εσωτερικό, μη χρησιμοποιείτε το μικροσκόπιο, αλλά απευθυνθείτε στον πλησιέστερο αντιπρόσωπο της Nikon.

- 3. Απόρριψη του μικροσκοπίου**

Για την αποφυγή βιολογικού κινδύνου, απορρίψτε το μικροσκόπιο ως μολυσμένο εξοπλισμό σύμφωνα με τη συνήθη διαδικασία του εργαστηρίου σας.

Notes on Handling the System

(1) Installation or storage location

The microscope is a precision optical instrument. Using or storing the instrument under unsuitable conditions may damage it or may have an adverse effect on its precision. The following conditions should be kept in mind when selecting the installation location.

- Avoid installing in a place exposed to direct sunlight, or directly under room lights or any other bright place. The image quality deteriorates in bright surroundings because of the extraneous light entering the objective.
- Select a location having a temperature from 0 to 40 C and a relative humidity of 85% or less. (If installed or stored in a location subject to high temperatures and humidity, mold or condensation may form on the lens, resulting in lowered performance and possible damage to the microscope.)
- Install in a place with little dust and dirt.
- Install in a level place free from vibrations.
- Install on a sturdy desk or table that can bear the weight of the microscope.
- Select a layout that allows easy detachment of the power cord from the AC inlet of this microscope in the event of emergency.
- This microscope emits weak electromagnetic waves. The accuracy of any precision electronic equipment may be adversely affected if positioned too close. If the microscope affects TV or radio reception, move the radio or TV further away from the microscope.

(2) Carrying the microscope

The microscope is a precision optical instrument. Handle it carefully and do not subject it to strong physical shocks. The accuracy of the objective in particular may be adversely affected by even a weak physical shock.

- Securely hold the microscope at the bottom front and back when transporting it.
- Do not grasp the focus knobs, eyepiece tube, stage, etc. when carrying the microscope. This could cause the part to come off, resulting in damage to the microscope.



(3) Handling lamps

- Do not touch the lamp glass with bare hands. This may soil the glass surface, degrade performance, damage the lamp, and/or reduce the life expectancy of the lamp. Wear gloves or use a piece of cloth when handling lamps. If the glass surface becomes dirty, wipe with clean cloth lightly moistened with alcohol.
- Do not subject the lamp to shocks or vibrations as this may damage the lamp or shorten its life expectancy.

Notes on Handling the System

- When replacing the lamp, check that the contacts are not damaged. If they are damaged, the lamp may not light or may overheat. Also, be sure to insert the lamp into the socket as far as it will go. If the lamp is installed improperly, it may fall out or overheat or smoke due to poor contact. Be sure to securely install the lamphouse cover after replacing the lamp.
- Do not break the used lamps; instead dispose of them as special industrial waste or according to the laws applicable to your municipal waste system.

(4) Focus knobs

Do not rotate the left and right knobs in opposite directions at the same time. Also, do not continue to rotate the coarse focus knob after the stage has reached the upper or lower limit of its motion. These actions will damage the microscope.

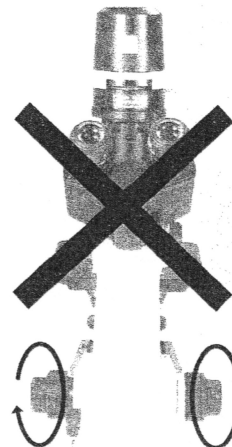
**(5) Objectives**

When observing suspended cells in the container, it is necessary to set the objective closer to the container than usual in order to achieve proper focus. If the objective is switched while set this close, it will strike the end of the container. Lower the objective before rotating the revolving nosepiece when it has been set close like this.

Also, before placing large containers on the stage, be sure that the tip of the objective does not stick out farther than the stage surface.

Do not twist in opposite directions.

(6) ϕ 35-mm petri dishes

When using a ϕ 35-mm petri dish, always attach the supplied round-holed ring to the stage. Using the long-holed ring instead may result in the dish falling through the opening.

(7) Absolute alcohol

When using absolute alcohol to wipe away immersion oil, always follow the instructions provided by the manufacturer. Keep this flammable liquids away from fire or sparks.

Names of Parts

This microscope consists of the parts shown in the figure below.

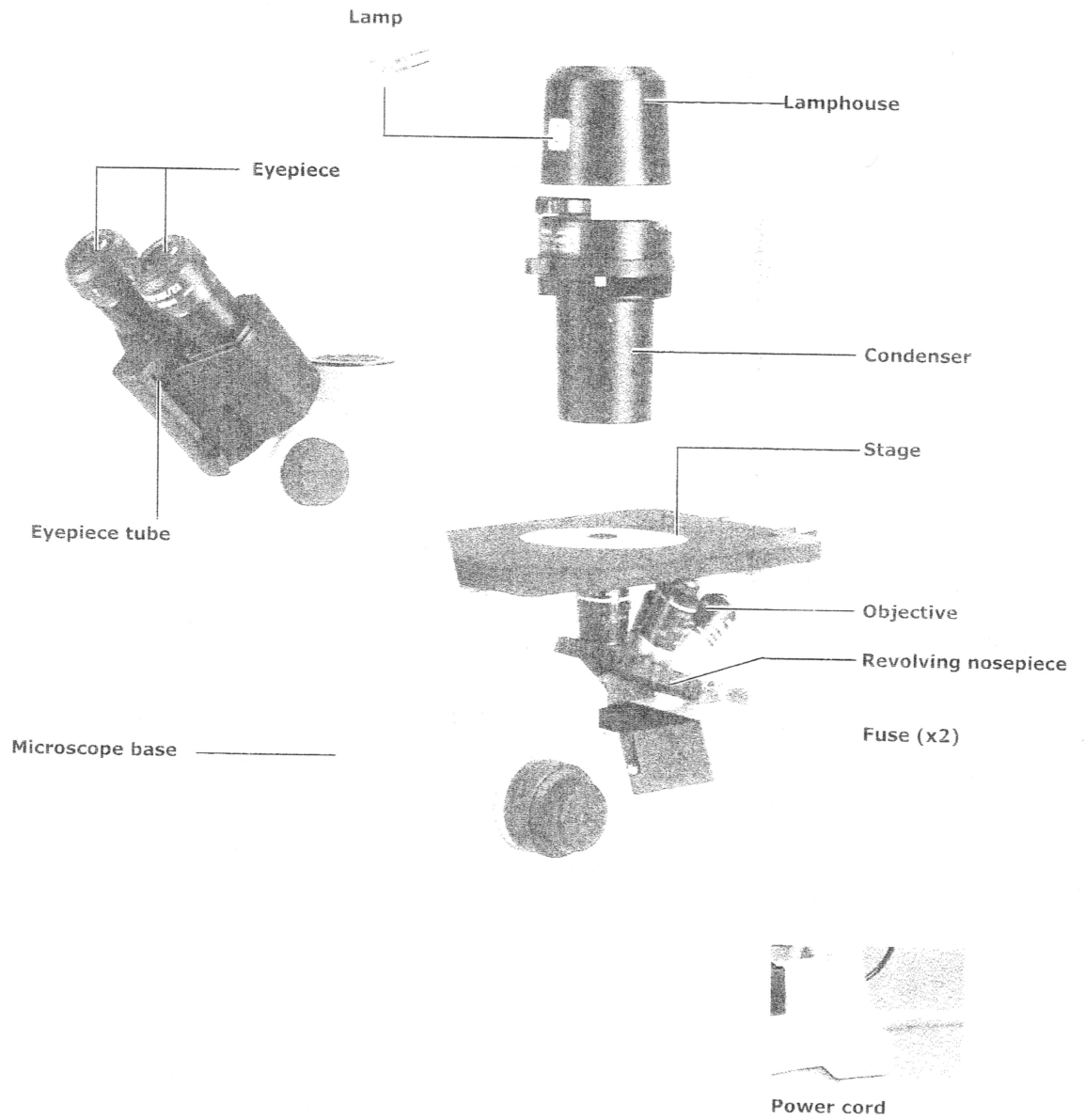

This figure shows an ECLIPSE TS100-F with ELWD condenser.

Names of Operational Parts

Filter holder

Holds up to two filters, such as the GIF filter for phase contrast microscopy and NCB filter for bright-field microscopy.

Condenser aperture diaphragm lever

Moving the lever to the right opens the aperture and moving the lever to the left closes the aperture. Closing down the aperture allows observation of transparent specimens even under bright-field microscopy though its resolution is reduced.

Fully open the aperture diaphragm during phase contrast microscopy. During bright-field microscopy, close the aperture diaphragm to 70% of the numerical aperture of the objective to get a sharp image with good contrast.

(The aperture diaphragm lever works the same for HMC condenser. Fully open the aperture diaphragm during HMC microscopy.)

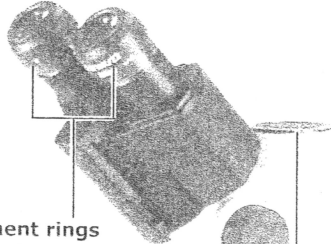

Diopter adjustment rings

Adjust independently to compensate for the difference between your left and right eye. (P.59)

Optical path changeover knob (TS100-F only)

Switches the light path between the binocular eyepieces and the vertical tube.

PHOTO: 0% to the eyepieces and 100% to the vertical tube.

BINO: 100% to the eyepieces and 0% to the vertical tube.

The TS100 does not have this feature.

Vertical tube (TS100-F only)

Accepts various types of adaptors to allow the attachment of a camera or other photomicrographic equipment. The TS100 does not have this feature.



Brightness Adjuster

Turn clockwise to increase voltage to the lamp and to brighten the viewfield.

Turn counterclockwise to decrease voltage to the lamp and to darken the viewfield.

Power switch

Press down the rear-half of the switch to turn on the power and to light up the lamp. (The switch also lights.)

Press down the front-half of the switch to turn off the power and to turn off the lamp. (The switch also goes off.)

Lamphouse cover

To remove the cover, press the front and back hem and pull upward. Before replacing the lamp, (1) turn off the power, (2) unplug the power cord, and (3) wait for the lamp to cool.

Illumination pillar

Condenser clamp screw

Slider installation hole

This hole allows the installation of a Phase slider. (The HMC condenser has the hole for installing the HMC slider.)

Mechanical stage installation screw holes (bottom panel)

Water tray

Water tray cover clamp screw

Fine focus knob

Coarse focus knob

Coarse torque adjustment ring

Adjusts rotation torque of the coarse focus knob.

Nameplate

AC inlet

Fuse holder (voltage selector)

Lamp cable connector

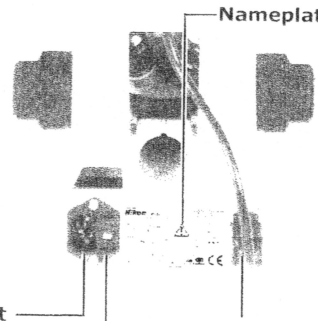
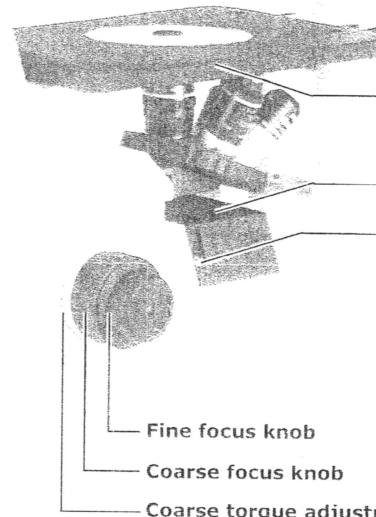

This figure shows an ECLIPSE TS100-F with ELWD condenser.



1

Microscopy

1 Turn on the lamp.

Turn on the power to the microscope (press down the rear-half of the power switch) to turn on the lamp. Adjust the brightness of the viewfield with the brightness adjuster. (Turn clockwise to increase brightness. Turn counterclockwise to decrease brightness.)

When using the TS100-F, set the optical path changeover knob to BINO before adjusting the brightness of the viewfield.

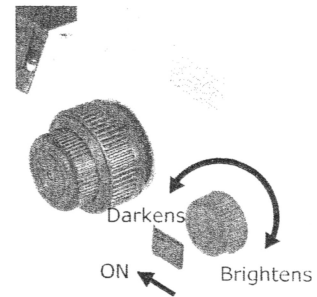

2 Adjust the interpupillary distance.

Looking through the eyepieces, adjust the distance between the binocular eyepieces so that the left and right viewfields overlap to form a single image. (This operation sets the distance between the eyepieces to match that between the operator's eyes.)

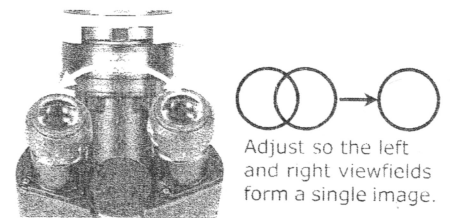

3 Set the diopter adjustment ring to the reference position.

Turn the diopter adjustment ring on the right eyepiece to align the 0 line with the reference line. Also align the 0 line of the left diopter adjustment ring with the reference line.

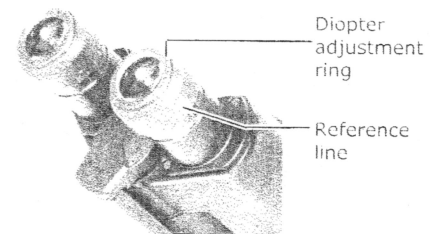

4 Fully open the aperture diaphragm.

Move the aperture diaphragm lever on the condenser to the full right to fully open the aperture.

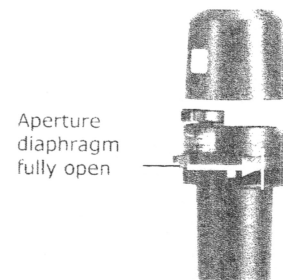

5 Set the specimen in place.

Place a specimen on the stage. Adjust its position so that the center of the container (that has the even thickness) comes under the optical path.

When using a ϕ 35-mm petri dish, always attach the supplied round-holed ring to the stage to prevent the dish from falling off.

(See P.67 when using other containers.)

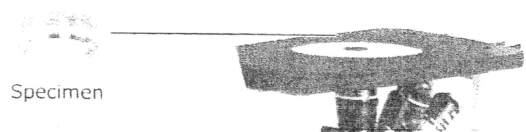

6 Adjust the diopter.

Adjust the diopter adjustment rings of the eyepieces according to the visual power of your left and right eyes. Once this adjustment is complete, full performance of the objectives will be properly achieved, including their parfocality.

- (1) If a Phase slider or HMC slider is set, enter an empty hole into the optical path or remove the slider from the condenser.
- (2) Place the 10x objective in the optical path. Turn the coarse and then the fine focus knob to bring the specimen into focus.
- (3) Place the 40x objective in the optical path, and turn the focus knobs to bring the specimen in focus. (When the 40x objective has a correction ring, adjust it to compensate for the thickness of the container. See P.70 for details.)
- (4) Place the 10x objective in the optical path again. Look through the right eyepiece with your right eye and, without touching the focus knobs, turn the right diopter adjustment ring to bring the specimen into focus.
- (5) Look through the left eyepiece with your left eye and, without touching the focus knobs, turn the left diopter adjustment ring to bring the specimen in focus.
- (6) Repeat steps (3) through (5).
- (7) If a phase slider or HMC slider was removed, return it to its original position.

Remove the slider if any.

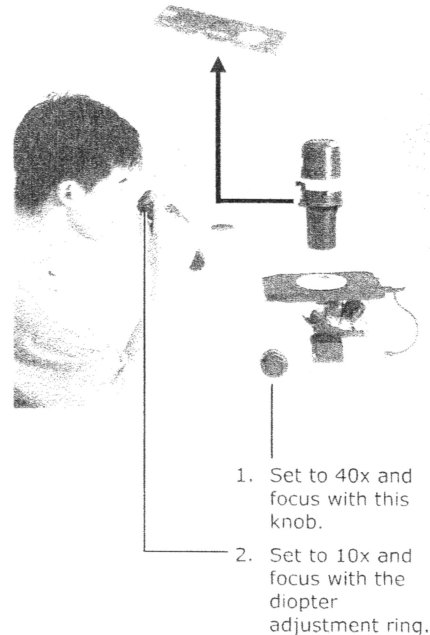

7 Observe the specimen.

Observe the specimen using the optimal microscopy method.

For phase contrast microscopy, see P.60.

For Hoffman modulation contrast microscopy, see P.62.

For bright-field microscopy, see P.65.

8 Turn off the lamp.

Press down the front-half of the power switch to turn off the lamp. After the lamphouse cools, cover the microscope with a vinyl cover so that it does not gather dust.

2**Phase Contrast Microscopy**

In order to perform phase contrast microscopy, the following items are required: an ELWD condenser, objectives for phase contrast microscopy, a phase slider (either non-centerable or centerable), an annular diaphragm Ph2 (when Ph2 objective is used), a GIF filter and a centering telescope (only when a centerable phase slider is used).

1 Attach the ELWD condenser.

Attach the ELWD condenser to the illumination pillar.

2 Attach the phase slider.

Insert the phase slider into the condenser.

(When you are planning to use a Ph2 objective, attach the annular diaphragm Ph2 to the slider in advance.)

3 Insert a GIF filter.

Place a GIF filter on the filter holder. (Voluntary.)

The GIF filter will improve the contrast of the phase contrast image.

4 Fully open the aperture diaphragm.

Move the aperture diaphragm lever on the condenser to the rightmost to fully open the aperture. Always fully open the aperture diaphragm for phase contrast microscopy. If the aperture diaphragm is closed, it will obstruct the annular diaphragm and the phase contrast effects cannot be obtained.

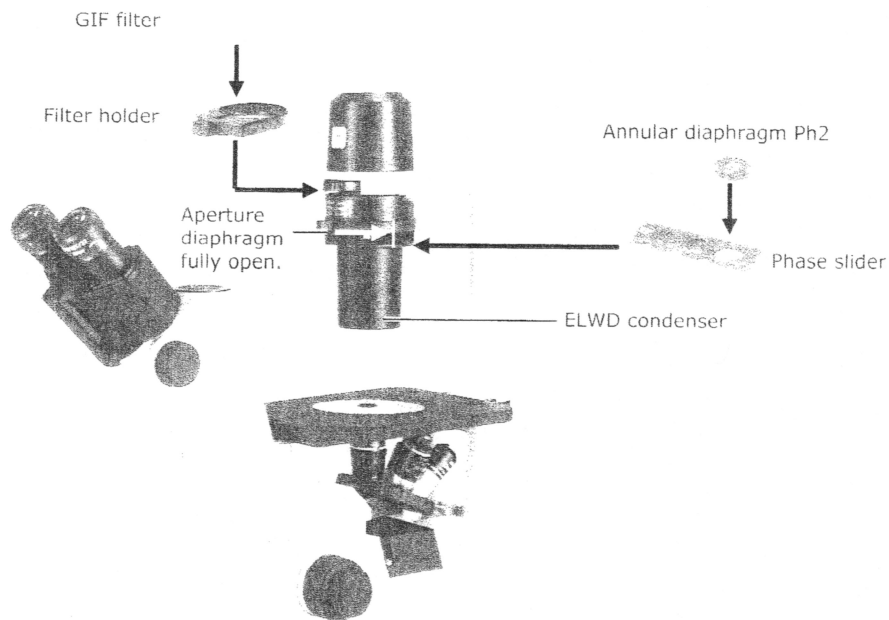

5 Center the annular diaphragm. (Only when using a centerable phase slider.)

Center the annular diaphragm so that it aligns with the phase ring of the objective. Perform this adjustment with the center of the container (having an even thickness) in the optical path. Avoid the periphery of the container.

- (1) Place the 10x phase contrast objective (Ph1) in the optical path.
- (2) Slide the phase slider to place the Ph1 annular diaphragm in the optical path.
- (3) Taking care not to alter the position of the diopter adjustment ring, remove one eyepiece from the eyepiece tube and insert a centering telescope in its place.
- (4) Holding down the flange of the centering telescope, turn the eyepiece of the centering telescope and focus on the objective phase ring.
- (5) Insert two hexagonal screwdrivers into the centering holes on the phase slider and, while looking through the centering telescope, center the Ph1 annular diaphragm image so that it aligns with the phase ring.
- (6) If you are using an objective with a Ph code other than Ph1, place that objective and the annular diaphragm having the same Ph code as that objective in the optical path, and center the annular diaphragm in the same manner described above.

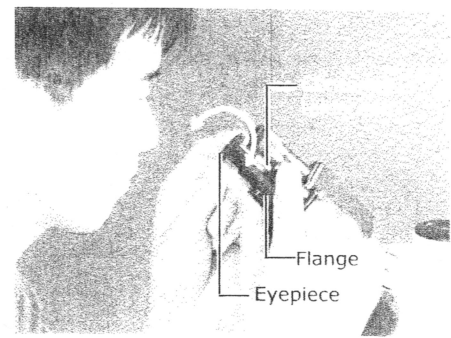

Annular diaphragm Phase ring image
image

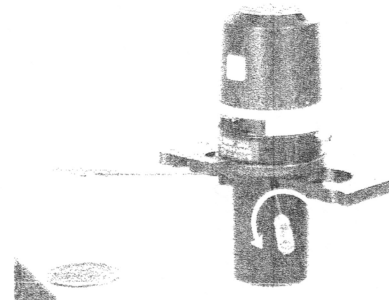
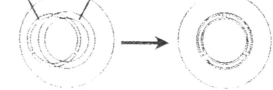

6 Select the desired phase contrast objective.

Turn the revolving nosepiece and place the phase contrast objective of the desired magnification in the optical path. (Turn the revolving nosepiece until you feel it click in place.)

Place the annular diaphragm having the same Ph code as the objective in the optical path.

7 Place the annular diaphragm corresponding to the objective in the optical path.

Place the annular diaphragm having the same Ph code as the objective in the optical path and observe. Since optical conditions worsen by the difference in the thickness of the container depending on the location, the center of the annular diaphragm may become displaced. If the contrast suddenly worsens, check the condition of the setup and, if necessary, center the annular diaphragm again.

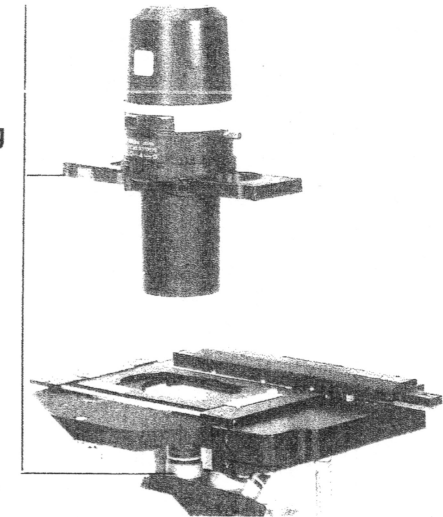

8 Adjust the correction ring on the objective.

If the objective has a correction ring, adjust the ring according to the thickness of the container. For details, see P.70.

3**Hoffman Modulation Contrast (HMC) Microscopy**

In order to perform HMC microscopy, the following items are required: an HMC condenser, objectives for HMC, an HMC slider (with slit diaphragms), and a centering telescope.

1 Attach the HMC condenser.

Attach the HMC condenser to the illumination pillar.

2 Attach the HMC slider.

Insert the HMC slider into the condenser.

(Attach the slit diaphragm to the HMC slider in advance if the slit diaphragms are removed from the slider. See P.79 for details.)

3 Remove the filters.

If there are any filters in the filter holder, remove them all or remove the filter holder itself.

4 Fully open the aperture diaphragm.

Move the aperture diaphragm lever on the condenser to the rightmost to fully open the aperture. Always fully open the aperture diaphragm for HMC microscopy. If the aperture diaphragm is closed, it will obstruct the slit diaphragm and the proper image cannot be obtained.

Remove all filters.

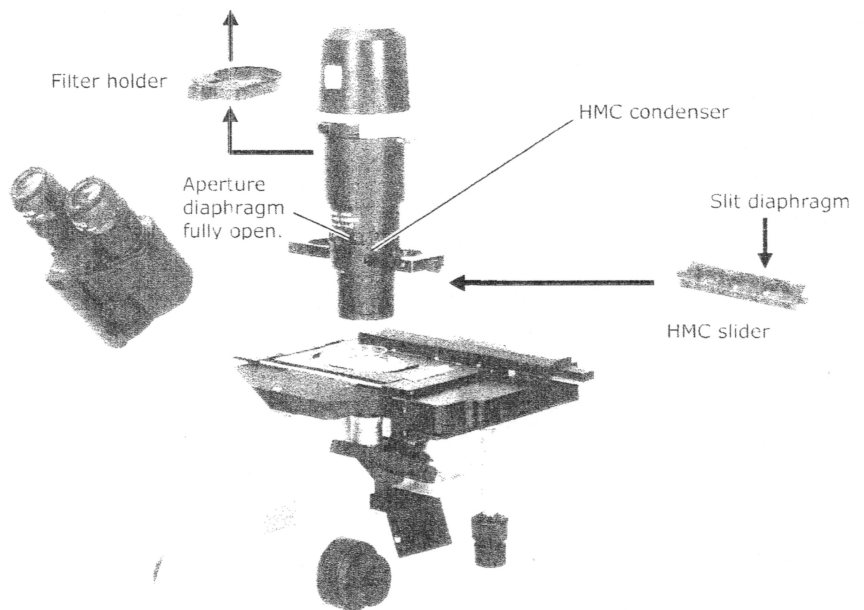

5 Orient the slit diaphragm.

Orient the slit diaphragm so that it properly overlaps the modulator (focal plane pattern) on the HMC objective.

- (1) Place the 10x HMC objective (MC1) in the optical path.
- (2) Slide the HMC slider to place the MC1 slit diaphragm in the optical path.
- (3) Taking care not to alter the position of the diopter adjustment ring, remove one eyepiece from the eyepiece tube and insert a centering telescope in its place.
- (4) Holding down the flange of the centering telescope, turn the eyepiece of the centering telescope and focus on the objective modulator (focal plane pattern) and slit diaphragm image.
- (5) Taking care not to alter the position of the correction ring on the objective (if any), turn the modulator ring on the objective to orient the modulator pattern in the direction in which you wish to apply contrast. Be sure at this time, to closely observe where the slit diaphragm image is located versus the modulator pattern.

- (6) Remove the MC1 slit diaphragm from the optical path. Then, using a hexagonal screwdriver, press one of the grooves in the slit diaphragm's circumference and rotate the diaphragm so that the lengthwise direction of the slit image becomes parallel to the modulator's G area. (Re-insert the MC1 slit diaphragm in the optical path to check whether or not the two are parallel. For fine adjustment, turn the modulator ring.)
- (7) Insert two hexagonal screwdrivers into the centering holes of the HMC slider. Then, while looking through the centering telescope, adjust so that the slit diaphragm image perfectly overlaps the modulator's G area.
- (8) If you are using an objective with an MC code other than MC1, place that objective and the slit diaphragm having the same MC code as that objective in the optical path and orient them in the same manner described above.

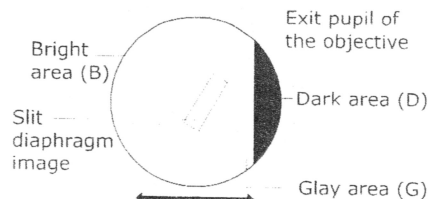
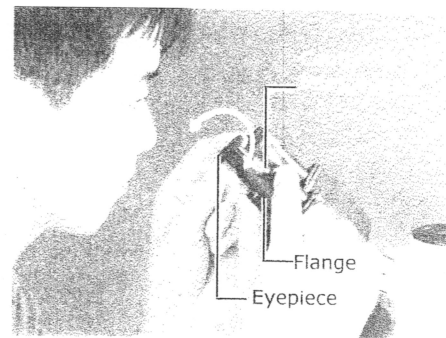

The contrast is attained in the direction of the arrow. The modulator and slit diaphragm image.

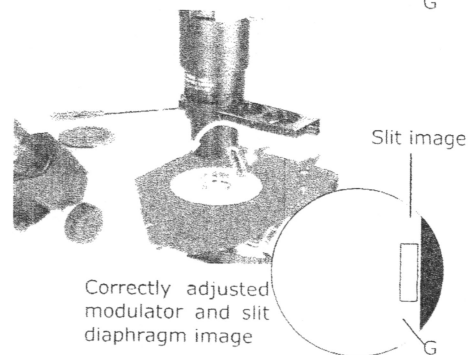
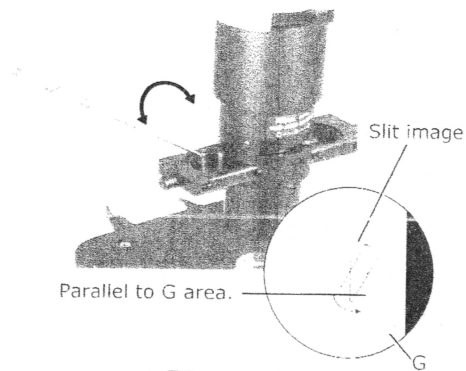
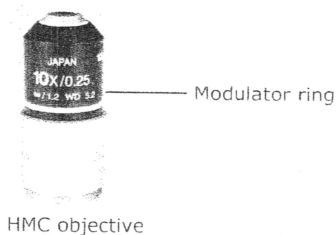

6 Select the desired HMC objective.

Turn the revolving nosepiece and place the HMC objective having the desired magnification in the optical path. (Turn the revolving nosepiece until you feel it click in place.)

7 Place the slit diaphragm corresponding to the objective in the optical path.

Place the slit diaphragm having the same MC code as the objective in the optical path and observe.

Depending on the specimen, changing the direction of the contrast may make easier observation.

Change the direction of the specimen by rotating the container, or change the direction of the modulator and slit diaphragm as necessary.

8 Adjust the correction ring of the objective.

If the objective has a correction ring, adjust the ring according to the thickness of the container. For details on adjusting this correction ring, see P.70.

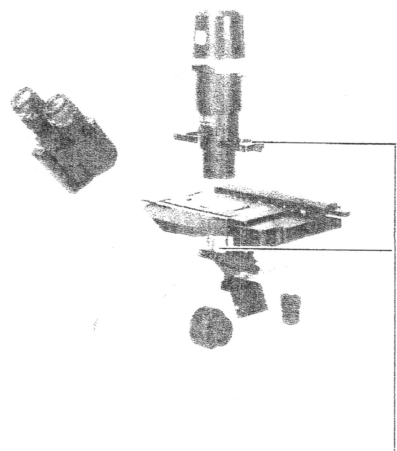

Place the slit diaphragm having the same MC code as the objective in the optical path.

Supplementation >

If your specimen is as shown in the figure (a) below, further attention must be given on the direction of the modulator and the slit diaphragm. The refractive plane produced by the boundary of the solution has a large gradient. When the boundary of the solution is laid perpendicular to the contrast direction of the modulator (the direction the contrast is attained), the specimen image cannot be observed clearly due to extremely strong contrast (see figure (b)).

In this case, rotate the modulator so that the contrast direction becomes parallel to the boundary of the solution (see figure (c)). Do not forget to adjust the position of the slit diaphragm at the same time.

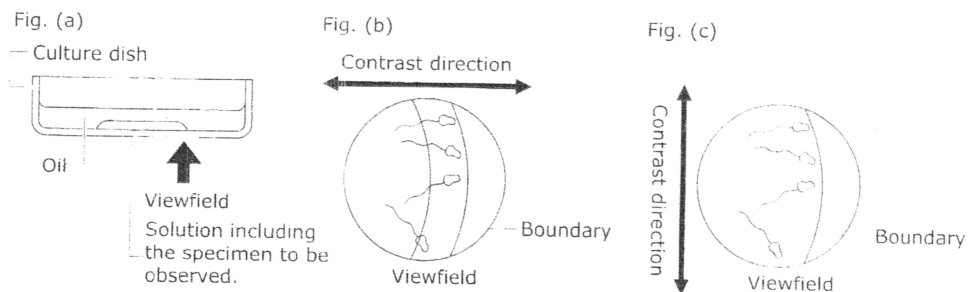

4

Bright-field Microscopy

1 Remove the annular diaphragm and slit diaphragm from the optical path.

If a Phase slider or HMC slider is set, enter an empty hole into the optical path or remove the slider.

2 Insert an NCB filter.

Insert an NCB11 filter into the filter holder to change the illumination to the white light. Since the color temperature differs by the lamp voltage, turn the brightness adjuster till the background color becomes white. If the viewfield becomes too bright by this adjustment, add an ND filter to the filter holder.

3 Switch to the desired objective.

Turn the revolving nosepiece to enter the desired objective in the optical path. (Turn the revolving nosepiece until you feel it click in place.)

4 Adjust the aperture diaphragm.

Adjust the size of the aperture diaphragm so that it is 70% to 80% of the numerical aperture of the objective.

For details on adjusting the aperture diaphragm, see P.66.

Note that the aperture diaphragm is attached to the condenser and cannot be adjusted if the condenser has been removed.

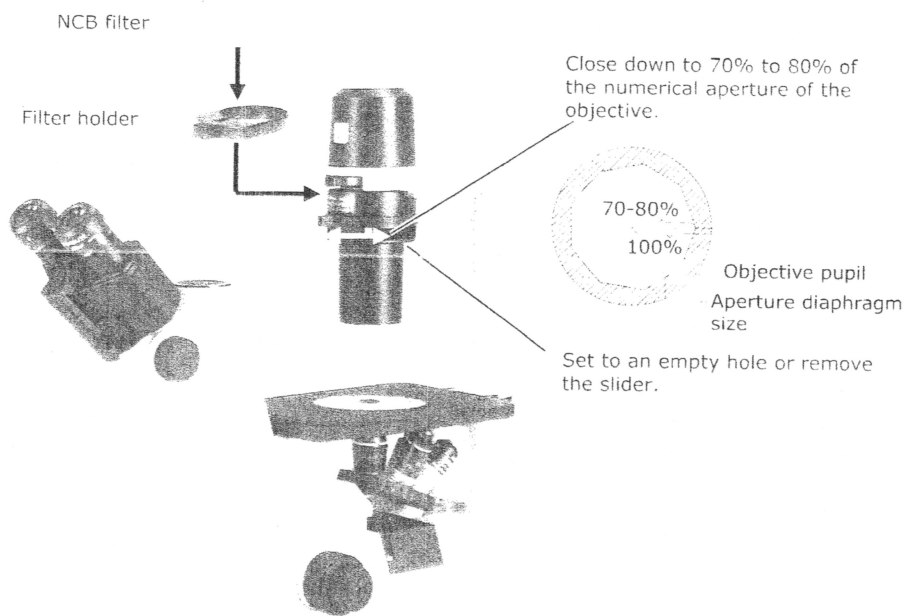

1

Aperture Diaphragm

The aperture diaphragm adjusts the numerical aperture (N.A.) of the illumination system.

Aperture of this diaphragm determines optical resolution, brightness, contrast, and depth of focus. Narrowing down the aperture diaphragm decreases resolution and brightness, and increases contrast and depth of focus. Because these characteristics are interrelated and cannot be controlled one by one, the aperture must be adjusted for each specimen and application.

Adjustment of the aperture diaphragm is especially important for bright-field microscopy, differential interference contrast microscopy, and photomicrography. Generally, aperture settings of 70 to 80% of the objective N.A. yield good images of appropriate contrast.

Adjust the aperture of the diaphragm while actually observing the diaphragm image through the eyepiece tube. Leftward rotation of the aperture diaphragm lever stops down the diaphragm. Rightward rotation opens it.

Remove one eyepiece, then insert the centering telescope. Hold the flange of the centering telescope with one hand and rotate its eyepiece for focusing. The images of the objectives exit pupil (appears bright round) and the aperture diaphragm become visible. (If the image of the aperture diaphragm is not seen, stop down the aperture diaphragm further.) While observing these images, adjust the aperture diaphragm lever until the aperture of the diaphragm reaches 70 to 80% of the exit pupil of the objective.

Be sure to always fully open the aperture diaphragm when performing phase contrast microscopy. If the aperture diaphragm is closed, it will obstruct the annular diaphragm and the phase contrast effects cannot be obtained.

Be sure to always fully open the aperture diaphragm when performing HMC microscopy. If the aperture diaphragm is closed, it will obstruct the slit diaphragm and a proper image cannot be obtained.

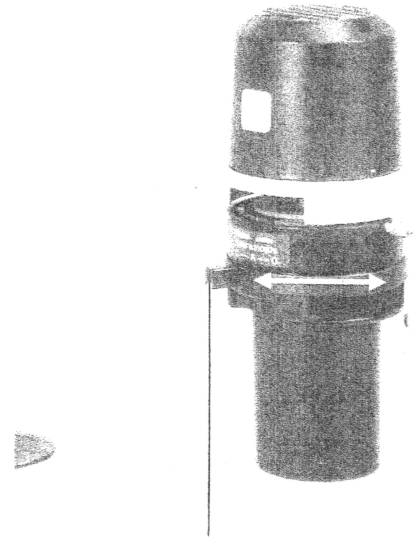

Condenser aperture diaphragm lever

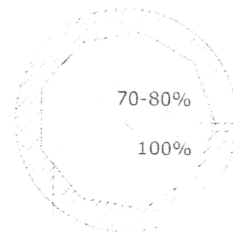
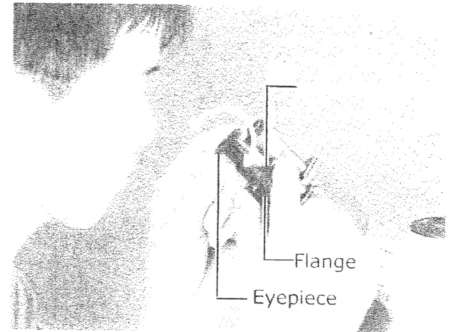

The exit pupil of the objective

Aperture diaphragm image

The appropriate size of the aperture diaphragm

2 Specimen and Stage

1 Round-holed and long-holed rings

When using a small container such as a ϕ 35-mm petri dish, always attach the supplied round-holed ring to the stage. Using the long-holed ring instead may result in the dish falling through the opening.

Attach the long-holed ring to the stage when using relatively large containers, such as microplates.

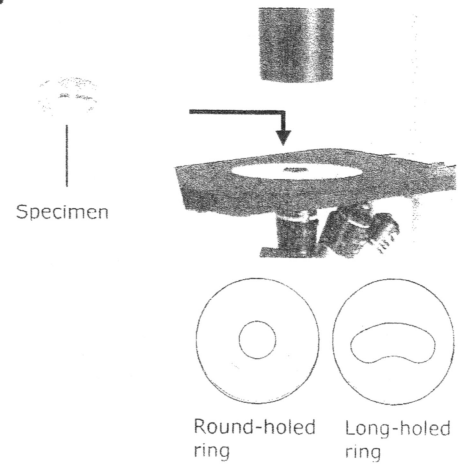

2 Observing suspended cells

When observing suspended cells in the container, it is necessary to set the objective closer to the container than usual in order to achieve proper focus. If the objective is switched while set this close, it may strike the edge of the container. Be sure to first lower the objective before rotating the revolving nosepiece when it has been set close like this.

3 Using the mechanical stage

For details on attaching the mechanical stage, see P.80.

Turning the upper knob of the mechanical stage moves the stage back and forth while turning the lower knob moves it left and right. Take care not to bend the specimen holder frame as it is coupled with a thin plate.

96-hole plates can be directly inserted into the specimen holder frame. Insert other containers into the specimen holder frame using the assorted specimen holders.

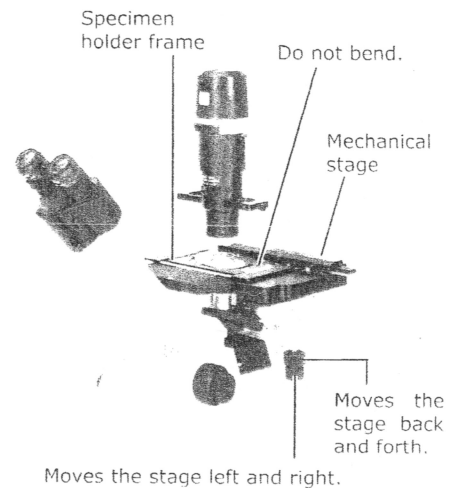

Blood cell count plate holder (35x76-mm)

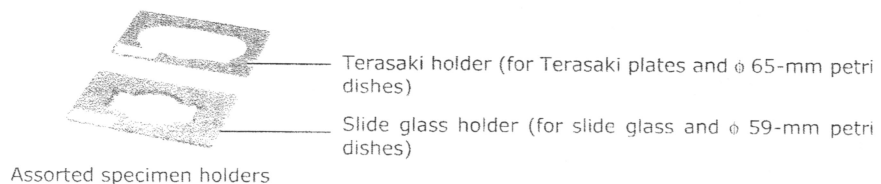

4 Using large containers

When using oblong containers, more stable observations are possible by attaching a sub-stage to the sides of the stage. (For details on attaching the sub-stage, see P.80.)

When using a large, thick container, remove the condenser and place the container on the stage. Note that only simple bright-field microscopy is possible while the condenser is removed.

Before placing a large container on the stage, check that the tip of the objective does not stick out beyond the top surface of the stage.

Remove the condenser for observations when using a large container.

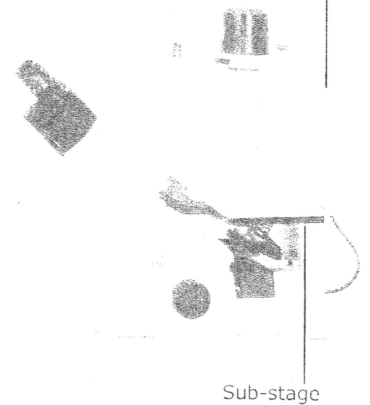

3 Focusing Device

The arrows in the figure shows the directions in which you rotate the focus knob to move the objectives.

The following shows the relationship between rotation of the knobs and movement of objective:

One scale division on the fine focus knob gives $2\ \mu\text{m}$ of objective movement.

One rotation of the fine focus knob gives 0.2 mm of objective movement.

One-tenth rotation of the coarse focus knob gives 3.8 mm of objective movement.

The coarse/fine focus knobs provide a 7-mm upward stroke and 3-mm downward stroke from the reference position.

The torque of the coarse focus knob can be changed by turning the coarse torque adjustment ring located at the base of the coarse focus knob on the right. Turning this adjustment ring counterclockwise increases the torque, while turning it clockwise decreases the torque. The torque of the coarse focus knob is pre-adjusted at the factory, but can be adjusted to taste by the user. Take care not to over-loosen the torque so that the revolving nosepiece does not fall of its own weight.

Do not rotate the left and right focus knobs in opposite directions at the same time or continue turning the coarse focus knob after the stage has reached the limit of its motion as this may result in damage to the equipment.

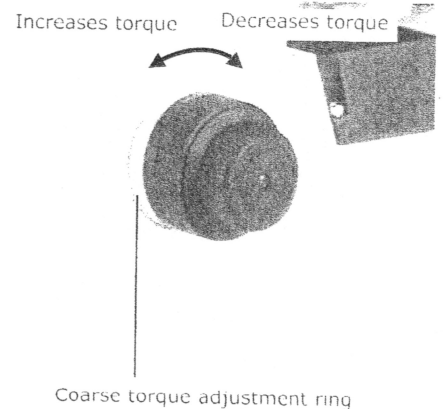
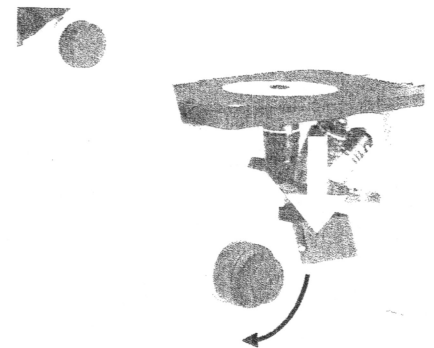

4 Filters

It is possible to insert up to two filters in the filter holder located under the lamphouse. The following filters are available for use as required by the application.

Note that all filters must be removed when performing HMC microscopy.

ND2 filter:	For brightness adjustment on normal microscopy and photomicrography. Reduces light quantity to 1/2. (Approx. 50% transmissivity)
ND8 filter:	For brightness adjustment on normal microscopy and photomicrography. Reduces light quantity to 1/8. (Approx. 12.5% transmissivity)
NCB11 filter:	For correcting the color temperature on normal microscopy and on color photomicrography (day light type). Remove this filter from the optical path when making photomicrography with tungsten type color film or monochrome film.
GIF:	Green interference filter. For improving the contrast in microscopy with monochromatic light and in monochrome photomicrography.
Heat insulation filter:	For reducing the influences of heat rays in the illumination light on the sample. Use the heat insulation filter for a sample quite sensitive to heat, though the microscope has a built-in heat insulation filter.



5 Objectives

1 Ph codes

A Ph code (PhL, Ph1 or Ph2) is printed on each of the objectives for phase contrast microscopy. Regardless of the magnification of the objective, be sure to insert the annular diaphragm having the same Ph code as the objective in the optical path when performing phase contrast microscopy. (The annular diaphragm must also be centered when using a centerable phase slider before making observations.)

Although Nikon also offers an objective for phase contrast microscopy with a Ph code of Ph3, this objective is for high-magnification applications and cannot be used for phase contrast observation with the TS100/TS100-F.

2 MC codes

An MC code (MC1, MC2 or MC3) is printed on each of the objectives for HMC microscopy. Regardless of the magnification of the objective, be sure to insert the slit diaphragm having the same MC code as the objective in the optical path when performing HMC microscopy. (The slit diaphragm position must also be aligned with the HMC objective modulator before making observations.)

3 Objective with correction ring

An inverted microscope is frequently used to observe specimens through the bottom plate (made of glass or plastic) of a laboratory dish or culture bottle. For such applications, because the bottom plate thickness differs, the normal objectives (for 0.17 mm thick cover glass) may not provide clear images, disabling the microscope from demonstrating its full performances. In such cases, use an objective with a correction ring to compensate for bottom plate thickness.

The objectives with correction rings are not intended to compensate for wedge-like changes of thickness at edges of a container. We recommend that they should be used for compensation for even thickness.

Adjusting the correction ring

- (1) Adjust the scale of the correction ring to the thickness of the bottom plate of the container. This thickness should be a measured value or the value stated by the container manufacturer.
- (2) Focus on the specimen with the focus knob.
- (3) Rotate the correction ring clockwise or counterclockwise slightly if the image has poor resolution and/or contrast. When the correction ring is rotated, the specimen image becomes slightly out of focus. Adjust the focus again with the fine focus knob.
- (4) If the resolution and contrast are improved, rotate the correction ring further in the same direction, then adjust the focus again.
If the resolution and contrast are deteriorated, rotate the correction ring in the reverse direction by the amount about double the previous turn, then adjust the focus.
In this way, rotate the correction ring in the same direction if a better image is obtained, or rotate it in the reverse direction if a poor image is obtained. Repeat this operation to find the best point.

The 0 mm position of the correction ring is used for microscopy of a specimen with no cover glass. We recommend that you take a note of the reading of a well-visible position on the correction ring. Your note should help when you later use containers having different bottom plate thickness.

4 Cover glass thickness

A specified cover glass thickness is indicated on each objective. ("∞ /0.17" indicates a cover glass thickness of 0.17 mm.)

For an objective with a 0.17 mark, place a specimen so that its cover glass (0.17 mm thick) faces the objective. (For an inverted microscope, set a specimen so that its cover glass faces down.) An objective with a 1.2 mark is for a slide glass with thickness of 1.2 mm. Place a specimen so that its slide glass faces the objective. (For an inverted microscope, set a specimen so that its cover glass faces up.)

When you observe a specimen in a laboratory dish or the like at high magnification through a glass not conforming to the specified thickness, we recommend use of an objective that has a correction ring capable of correcting the glass thickness error.

5 Oil immersion objectives

Objectives which have a black band around the tip and on which "Oil" is printed are oil immersion objectives. Oil immersion objectives are used by filling Nikon immersion oil between the tip of the objective and the specimen. Use non-fluorescent oil when performing fluorescence microscopy with an oil immersion objective intended for fluorescence microscopy.

Take care not to allow air bubbles

When filling with oil, take care that no air bubbles form inside the oil. The presence of air bubbles degrades the viewed image. To check for air bubbles, remove one eyepiece, fully open the aperture diaphragm, and look at the exit pupil of the objective (appears bright round). If it is difficult to see, remove one of the eyepieces, attach a centering telescope in its place, and observe while changing the focus by rotating the eyepiece of the centering telescope.

If there are bubbles in the oil, remove them by one of the following methods:

- Turn the revolving nosepiece slightly, moving the oil-immersed objective back and forth once or twice.
- Add more oil.
- Remove the oil and replace it with new oil.

Handling immersion oil

Use as little oil as possible. If too much oil is applied, the excess will flow onto the stage and other parts.

Any oil remaining on an oil-immersion type of objective or staining on the tip of a dry type of objective has a negative effect on viewing. After using oil, wipe all of it away and make sure that there is no oil on the tips of the other objectives.

To wipe away oil, wipe lightly 3 or 4 times using lens tissue dampened with absolute alcohol (ethyl alcohol or methyl alcohol). Items may be wiped more cleanly by making sure not to wipe with the same part of the tissue more than once. A nice finish may be obtained by wiping again with dry lens tissue.

**WARNING**

When using absolute alcohol, always follow the instructions provided by the manufacturer. Keep these flammable liquids away from fire or sparks.

Precautions when using immersion oil

- Make sure to securely tighten the cap after use. After adding oil to the container, securely tighten the base cap. Since the base cap may become loose by itself after having been used for a long time, periodically check to make sure it is tight. Oil may leak out if the cap is loose.
- Do not press on the container with excessive force. This may cause the oil suddenly spray from the container.
- Wipe off any oil that collects on the outside of the container during the course of use.
- Be careful so that oil does not get in your eyes. Although the Nikon immersion oil is not toxic, apply the first-aid measures listed below if it should come in contact with the skin or enter the eyes.
 - ◇ Contact with skin: Completely wash off with soap and water.
 - ◇ Enters the eyes: Rinse thoroughly with pure water (for at least 15 minutes) and seek medical attention.
- Do not place immersion oil in a location exposed to outside light (or UV light).



6

Hoffman Modulation Contrast Method

1 Hoffman Modulation Contrast System

The Hoffman Modulation Contrast System, designed by Dr. Hoffman, offers you a stable relief image which can well be compared to the differential interference contrast microscopy (DIC microscopy). But, unlike the DIC microscopy, you can observe the specimen inside the plastic containers since this system does not require its illumination to be polarized.

The Hoffman Modulation Contrast System for TS100 and TS100-F is made up of two components; a pattern called "modulator" (placed at the back focal plane of the HMC objective) and a slit diaphragm (to be installed in the HMC slider). (The HMC system for TS100 and TS100-F is a fixed contrast system and thus a polarized plate is not used.)

Modulators (objectives) and slit diaphragms come in pairs. Check that the MC codes (MC1, MC2 or MC3) displayed on both the modulator and the slit diaphragm are the same before using. Note that a correct image cannot be obtained if the MC codes do not match.

2 Principles of Modulation Contrast

Since human eyes, cameras, and films capture objects by perceiving differences in light intensity and/or color, they cannot see (or sense) the colorless, transparent cells or bacteria. These colorless transparent objects are called "phase objects" since they only change the phase of the light when the light passes through them.

The phase objects can be made visible by dyes, but their life will be deprived. In order to observe the living phase objects, differential interference contrast and phase contrast microscopy are invented, and modulation contrast microscopy likewise. The modulation contrast microscopy adopts the same optical system as the ordinary microscopes, but with some additional parts that convert the transparent specimen into the variation of light intensity. These additional parts modulate the amplitude of the light that passed through the specimen, thus changing the intensity of the light making up the visible image.

(In differential interference contrast and phase contrast microscopy, the phase objects are converted into the variations of light intensity by the phase change that occurs when the light passes through the specimen.)

Let's now think of a light that passes through a specimen. Since a phase object has the different refractive index as its surroundings, the light will be refracted at its border. (See figure 1 showing refracted light on trapezoidal phase object.) The same thing happens to every specimen.

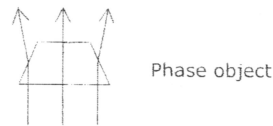

Fig. 1

See figure 2 for the principle of the modulation contrast. There is a slit diaphragm on the condenser aperture, and modulator inside the HMC objective. (The modulator is a density filter placed at the exit pupil of the HMC objective. It divides the exit pupil into three regions, dark, half-dark and transparent.)

If there is nothing on the specimen surface, the light passes through the half-dark region of the modulator and appears half-dark. If the light is refracted by the phase object, it passes either the dark or the bright region according to the difference in the refracted angle. The light then appears dark or bright according to the region the light passed through. In this way, the phase object is made visible.

In modulation contrast microscopy, the image appears in relief just like the differential interference contrast microscopy. The notable point is that there is no influence of double refraction, thus enabling you to observe the specimen without double refraction.

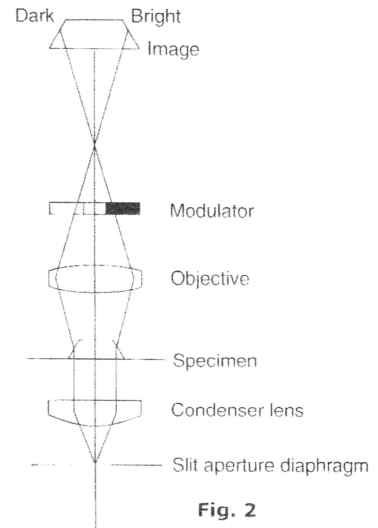

Fig. 2



7

Photomicrography (TS100-F Only)

When using the TS100-F, it is possible to attach a camera or photomicrographic equipment to the vertical tube for taking photographs or observing images on a TV monitor.

When using an episcopic-fluorescence attachment to take photographs of fluorescent images where the amount of light is weak, we recommend you use photomicrographic equipment with a built-in, high-sensitive exposure meter.

(Turning off the microscope's power switch will cut diascopic illumination light when photographing only fluorescent images.)

See the operation manuals accompanying any cameras or photomicrographic equipment to be used for details on proper handling.

1 Single lens reflex cameras

The following items are required in order to take photographs using 35-mm film with a single lens reflex camera. Assemble in the numerical order given.

<1> Photomicrographic vertical tube (secured by two clamp screws)

<2> PL lens (large projection lens)

<3> TMS-F mount adaptor

<4> Nikon single lens reflex camera body (recommended model: FE10)

(Note that the F401 and F50D cannot be used because the electrical contacts are shaped differently.)

<5> Eyepiece cap for camera

<6> Camera release

<7> 35-mm film

- (1) Look for the sample and make sure that illumination is even. (If illumination is uneven, make the proper adjustments.)
- (2) Switch the optical path to the vertical tube. (Set the optical path changeover knob to PHOTO.)
- (3) For bright-field microscopy, adjust the aperture diaphragm on the condenser.
- (4) Turn on the power of the camera.
- (5) Looking through the camera's viewfinder, determine the composition of the image and bring the image into focus.
- (6) Set the exposure time. Set the shutter dial to the position appropriate for the reading on the exposure meter when taking photographs manually or to "A" when taking photographs using automatic exposure.
To prevent vibration during mirror up of the camera, adjust the light level so that the shutter speed is 1/8 of a second or less. Extending the exposure time eliminates the photographing of vibrating images.
- (7) To prevent external light from entering, attach the eyepiece cap to the camera's viewfinder.
- (8) Click the shutter. Use the release if vibrations are a concern.

2 Photomicrographic equipment

The following items are required in order to take photographs using 35-mm film with photomicrographic equipment. Assemble in the numerical order given.



CAUTION

Do not use a large camera back on the photomicrographic equipment since the center of gravity becomes high and the microscope become unstable most likely to fall down.

- <1> Photomicrographic vertical tube (secured by two clamp screws)
- <2> PL lens (large projection lens)
- <3> Photomicrographic equipment
- <4> 35-mm film

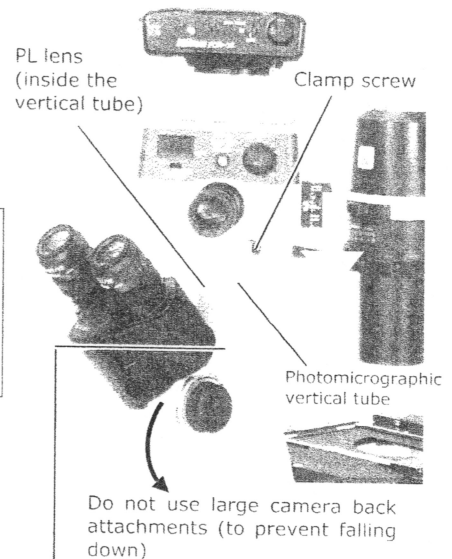

Securely tighten the two clamp screws.

- (1) Look for the sample and make sure that illumination is even. (If illumination is uneven, make the proper adjustments.) When using an NCB11 or color correction filter with color film under diasopic illumination, adjust the brightness level to obtain proper color and adjust the light level using ND filters.
- (2) Switch the optical path to the vertical tube. (Set the optical path changeover knob to PHOTO.)
- (3) For bright-field microscopy, adjust the aperture diaphragm on the condenser.
- (4) Turn on the power of the photomicrographic equipment.
- (5) Looking through the photomicrographic equipment's viewfinder, determine the composition of the image and bring the image into focus.
- (6) Set the light level to obtain the proper exposure time.
- (7) Press the shutter button (remote release).

3 TV cameras and digital cameras

- (1) Connect a C-mount camera having a camera head weighing 1 kg or less (to prevent the microscope falling down).
- (2) Connect the other equipment required such as a TV monitor and video printer according to the instructions given in the camera's operation manual.

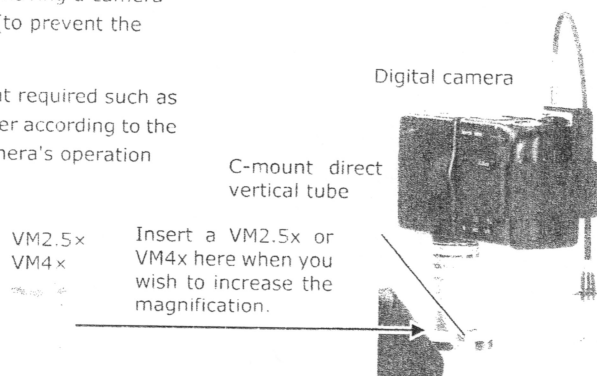



Be absolutely sure to read the chapter "Safety Precautions" and follow all instructions given there before assembling the microscope. In order to prevent electrical shock, also be absolutely sure to press the front-half of the power switch and turn the power off before assembly.

1 Assembling the Basic Set

Tools needed

Flathead screwdriver (for changing voltage)

1 Confirming the input voltage

Make sure that the input voltage indicated on both the nameplate on the rear panel of the microscope and to the immediate right of the AC inlet are the same as your local voltage. Do not use the microscope if the local voltage differs from that required by the microscope. Follow the instructions below if this is the case. Use of the microscope under the incorrect voltage may cause over-heating due to over-current, possibly resulting in a fire and damaging the microscope.

- If the voltage indicated on the nameplate differs from local voltage, do not turn on the power but contact your nearest Nikon representative immediately.
- If the voltage indicated to the immediate right of the AC inlet differs from local voltage, change the input voltage setting as described below before turning on the power. The following values may be set for the input voltage.
 - If the nameplate reads "100/110/120 V - ", the input voltage may be set to 100, 110 or 120 V AC.
 - If the nameplate reads "220/230/240 V - ", the input voltage may be set to 220, 230 or 240 V AC.

Switching the voltage

- (1) Press the front-half of the power switch to turn off the power. Unplug the power cord if it is connected.
- (2) Remove the fuse holder using a precision flathead screwdriver. (Use the tip of the minus driver to push the two lock plates toward the center of the fuse holder. The fuse holder pops out from the AC inlet.)
- (3) Remove the fuses and pull out the voltage selector inside the fuse holder.
- (4) Set the voltage selector so that the voltage displayed in the window of the fuse holder is the same as the local voltage to be used.
- (5) Re-attach the fuses and fuse holder in their original locations.

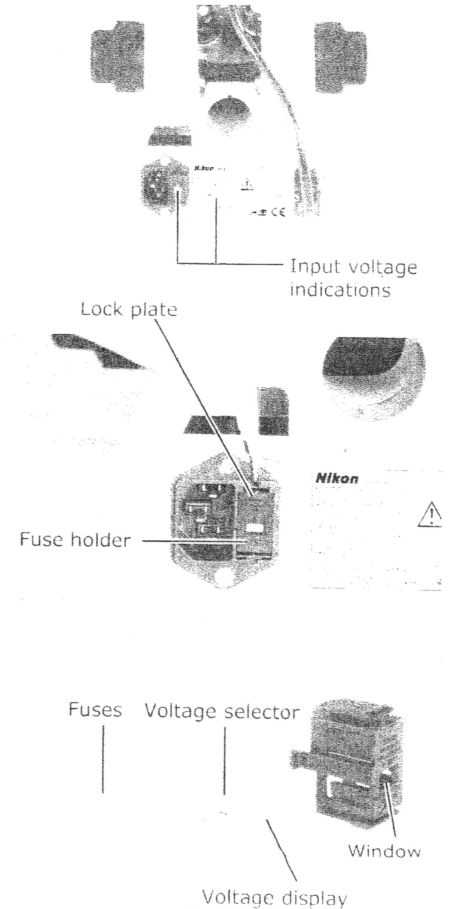

1 Assembling the Basic Set

2 Replacing fuses

In order to prevent electrical shock and/or damage to equipment, be sure to turn off the microscope's power (press the front-half of the power switch) and unplug the power cord before replacing fuses.

Use only the specified fuses. Use of other fuses may result in damage to equipment or fire.

Specified fuse: Two 250-V, 1-A time-lag, low-breaking 5x20 miniature fuses

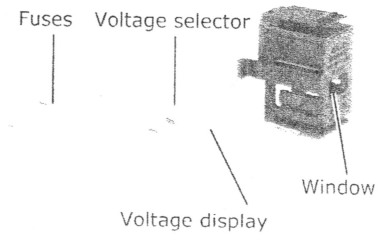

- (1) Press the front-half of the power switch and unplug the power cord if it is connected.
- (2) Remove the fuse holder using a flathead screwdriver. (See P.76.)
- (3) Remove the fuses and replace with new fuses.
- (4) Check that the voltage displayed in the fuse holder window matches the actual input voltage. (If it differs, change the voltage selector setting according to instructions on P.76.)
- (5) Re-attach the fuse holder in its original location.



3 Attaching (replacing) a lamp

In order to prevent burn injury and/or electrical shock when replacing a lamp, be sure to turn off the power (press the front-half of the power switch), unplug the power cord, and allow the lamp and surrounding area to cool sufficiently before opening the lamphouse cover.

Use only the specified lamp. Use of another type of lamp may result in damage to equipment or fire.

Specified lamp: 6V-30W halogen lamp
(PHILIPS 5761)

- (1) Remove the lamphouse cover by lightly pressing on the front and rear hem and pulling upward.
- (2) Handling the lamp using gloves or piece of cloth, firmly plug the lamp into the socket pin holes as far as it will go.
- (3) Return the lamphouse cover to its original position.
- (4) Plug the lamp cable connector into the socket on the rear of the microscope.

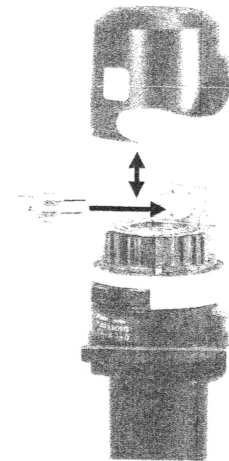

4 Attaching a condenser

Slide on the condenser to the illumination pillar and secure it by a clamp screw.

5 Attaching objectives

Objectives are screwed into the revolving nosepiece from the top of the stage. Attach objectives so that the magnification increases as the revolving nosepiece is turned clockwise as viewed from above.

6 Attaching eyepieces

Remove the caps from the binocular eyepiece tube and insert eyepieces. Be sure to attach eyepieces with the same magnification.

7 Connecting the power cord

Check that the microscope's power is turned off (the front-half of the power switch is pressed down). Connect the socket of the specified power cord to the AC inlet on the rear of the microscope and connect the plug to an AC electrical outlet. Be sure that connections are secure.

- Always use the power cord specified. Use of another power cord may result in damage to equipment or fire.
- When using an extension cord, be sure to use one that includes a PE wire (protective earth wire) and be sure it is connected securely.

This ends the assembly of the basic set.

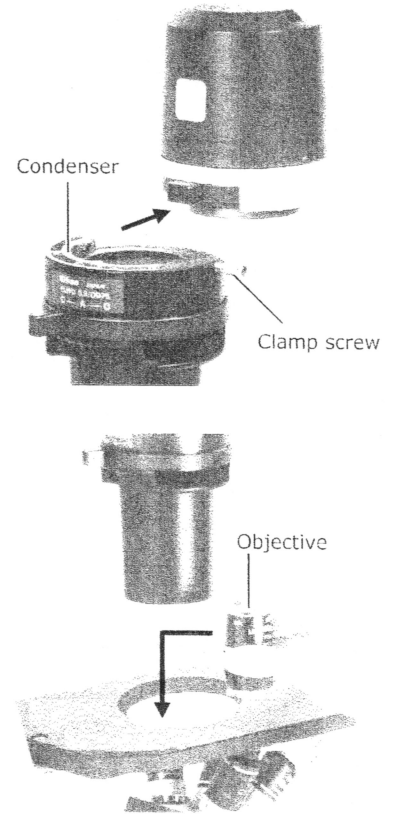

2

Assembling Components Not Included in the Basic Set

1 Components for phase contrast microscopy

An ELWD condenser, objective for phase contrast microscopy, phase slider (either centerable or non-centerable), annular diaphragm Ph2 (when Ph2 objectives are used), GIF filter and centering telescope (only when a centerable phase slider is used) are required in order to perform phase contrast microscopy.

Attach the condenser and objectives in the same manner as described for the basic set. For details on the centering telescope, please see the description given in section "III. Microscopy".

Insert the annular diaphragm Ph2 to the slider if you are planning to use an objective having a Ph2 indication.

Insert the slider with annular diaphragm attached into the condenser slider attachment hole.

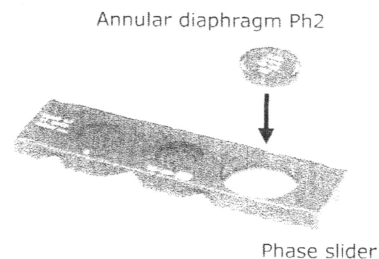

2 Components for HMC microscopy

An HMC condenser, objectives for HMC, HMC slider, slit diaphragms, and centering telescope are required in order to perform HMC microscopy.

Attach the condenser and objectives in the same manner as described for the basic set. For details on the centering telescope, please see the description given in section "III. Microscopy".

To remove a slit diaphragm already inserted, first sufficiently loosen the centering screws, and lift by holding the inside of the circumference. Take care not to press on the slit area.

Remove the tab on one side of the slider and insert into the condenser slider attachment hole. Re-attach the tab in its original location.

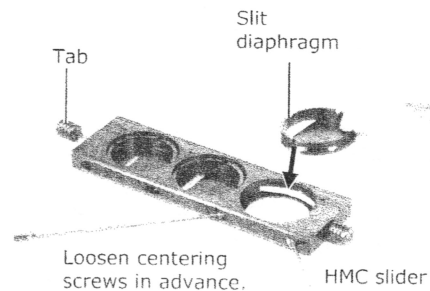

3 Mechanical stage

- (1) Remove the round-holed or long-holed ring from the stage if any is attached.
- (2) Peel off the securing tapes for transportation (at two locations).
- (3) Loosen the bolts fixing the shipping clamp for three turns.
- (4) Place the mechanical stage on top of the microscope stage and secure from the bottom of the stage using two hexagonal socket head bolts.
- (5) Remove the shipping clamp from the mechanical stage.

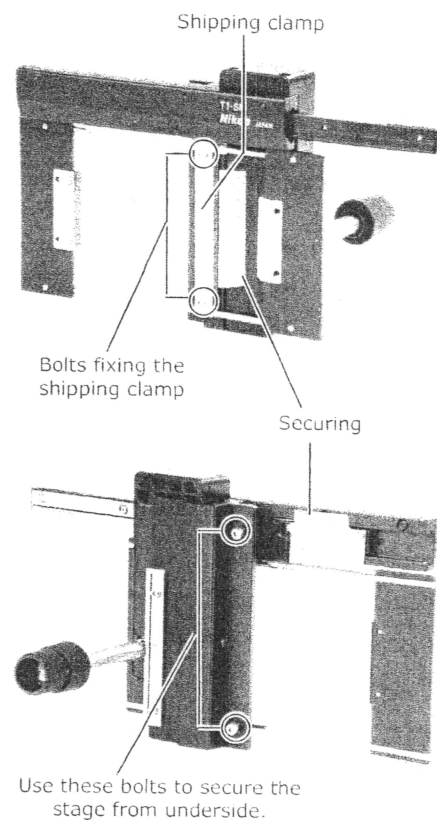

4 Sub-stages

Sub-stages are secured to the microscope's stage using the screw holes for attaching a mechanical stage.

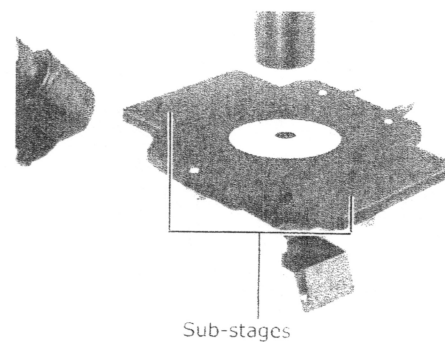

Even though it is not damaged, microscope performance itself can be adversely affected by misuse. If any of the following symptoms arise, be sure to first check the following table for possible causes before requesting service. Contact your nearest Nikon representative if the problem cannot be resolved using the following table.

1 Optical

Viewfield vignetting, viewfield only partially visible, uneven brightness, or dark image

Causes		Corrective Measures
Revolving nosepiece not in clickstop position (Objective not in optical path).	⇒	Rotate revolving nosepiece to clickstop position to place an objective in optical path.
Lamp is not installed properly.	⇒	Install the lamp correctly. (P.77)
Lamp voltage is low.	⇒	Brighten viewfield using brightness adjuster. (P.58)
Dirt or dust on lens (condenser, objective, eyepiece).	⇒	Clean the lens. (P.86)
Specimen holder on the stage is in optical path.	⇒	Move the holder.
Phase slider (or HMC slider) in midway position.	⇒	Slide to clickstop position.
Filter is not inserted properly.	⇒	Check the filter holder. (P.60) Remove all filters from optical path for HMC observations.
Optical path changeover knob position is wrong.	⇒	Select optical path to be used. (P.57)

Dirt or dust in viewfield.

Causes		Corrective Measures
Lens is dirty. (Condenser, objective, secondary objective, or eyepiece)	⇒	Clean the lens. (P.86)
Specimen is dirty.	⇒	Clean the specimen.

Poor image quality (No effect of phase contrast; poor contrast or resolution)

Causes	Corrective Measures
(For phase contrast microscopy: No annular diaphragm is in optical path.	Use an annular diaphragm that matches the objective. (P.61)
(For phase contrast microscopy: Ph codes of objective and annular diaphragm do not match.	Use an objective and annular diaphragm having the same Ph code.
(For phase contrast microscopy: Annular diaphragm image is not centered on phase ring.	Center the annular diaphragm. (P.61)
(For phase contrast microscopy: Aperture diaphragm is closed.	Fully open the aperture diaphragm. (P.60)
(For HMC microscopy: No HMC objective is in optical path.	Place an HMC objective in optical path.
(For HMC microscopy: MC codes of objective and slit diaphragm do not match.	Use an objective and slit diaphragm having the same MC code.
(For HMC microscopy: Slit diaphragm image is not adjusted to be contained in G area of modulator.	Adjust the position of the slit diaphragm. (P.63)
Condenser position is wrong.	Check for proper attachment to illumination pillar.
Bottom of culture container is too thick.	Use container with thickness around 1.2 mm.
Correction ring of objective is not in right position (when using objectives with correction rings).	Adjust the correction ring to match container thickness. (P.70)
Lens is dirty. (Condenser, objective, secondary objective, or eyepiece)	Clean the lens. (P.86)

2**Operational****Cannot focus even by moving objective to upper limit.****Causes**

Specimen surface is too far from stage surface.

**Corrective Measures**

Locate closer to stage surface.

Cannot focus with 20x or 40x objective.**Causes**

Culture container is too thick.

**Corrective Measures**

Use a culture container of thickness 2-mm or less.

Left and right images do not overlap in binocular observation.**Causes**

Needs interpupillary adjustment.

**Corrective Measures**

Perform interpupillary adjustment. (P.58)

Eyes get tired during observations.**Causes**

Needs diopter adjustment.

**Corrective Measures**

Adjust diopter for both left and right eyepieces. (P.59)

Loses focus over time.**Causes**

Torque of coarse focus knob is too loose.







**Corrective Measures**

Turn coarse torque adjustment ring to tighten torque so the revolving nosepiece does not fall on its own weight. (P.68)



3





Electrical**Lamp does not turn on even when power switch is on.**

Causes	Corrective Measures
No electricity.	 Plug power cord into AC inlet of microscope and electrical outlet. (P.78)
Lamp is not installed.	 Install the lamp. (P.77)
Lamp is burnt out.	 Replace the lamp. (P.77)
Not using the specified lamp.	 Use the specified lamp. (P.77)
Fuses are blown.	 Replace the fuses. (Use only the specified type.) (P.77)
Lamp cord is disconnected.	 Connect to connector on rear of microscope. (P.77)

Brightness varies.

Causes	Corrective Measures
Voltage fluctuations in local power too large.	 Use an AC power supply with stable current meeting local safety regulations.

Lamp flickers. Brightness is unstable.

Causes	Corrective Measures
Lamp is about to burn out.	 Replace the lamp. (P.77)
Bad connection.	 Secure all connections.
Fuse holder is not attached securely.	 Attach the holder securely. (P.77)
Room voltage is fluctuating erratically.	 Use an AC power supply with stable current meeting local safety regulations.
Lamp is not securely inserted in socket.	 Insert the lamp securely. (P.77)

Lamps burn out quickly.

Causes	Corrective Measures
Not using the specified lamp.	Use the specified lamp.
Input voltage is wrong.	Set voltage selector to match the local voltage. (P.76)



1

Lens Cleaning

- Dust is best removed with a soft brush or gauze.
- More persistent dirt, such as fingerprints, grease and oil, may be removed with soft cotton, lens tissue, or gauze lightly moistened with absolute alcohol (ethyl alcohol or methyl alcohol).
- Do not use any solvents other than absolute alcohol as they may damage the lens adhesion surfaces. Especially avoid petroleum benzine when cleaning parts such as filters or the secondary objective.
- Absolute alcohol is extremely flammable. Keep this flammable liquids away from fire or sparks and when setting the power switch on and off.
- Always follow the instructions provided by the manufacturer when using absolute alcohol.

2

Cleaning the Microscope

- We recommend that you use a silicon cloth to clean the microscope.
- For persistent dirt, dampen a piece of gauze with neutral detergent and wipe lightly.
- Using organic solvent could result in discoloration of the plastic parts.

3

Disinfecting the Microscope

- We recommend that you use 70% medical alcohol for normal disinfection of the microscope.
- In case of spillage of a sample onto the microscope, determine whether the sample is hazardous. If the sample is hazardous, follow the standard procedure of your laboratory.
- Using organic solvent could result in discoloration of the plastic parts.

4

Storing the Microscope

- When the microscope is not in use, cover it with the vinyl cover, and store it in a dry place not subject to mold.
- Before putting on the vinyl cover, turn off the power switch on the microscope (press down the front-half of the switch), and wait until the lamp is cool.
- We especially recommend that the objectives and eyepieces be kept in a container (such as a desiccator) with desiccant in it.

5

Regular Inspection

- Regular inspection of this microscope is recommended to maintain peak performance.
- Contact your nearest Nikon representative for details about regular inspection.



- (1) **Model name** ECLIPSE TS100
ECLIPSE TS100-F

- (2) **Dimension and Weight** ECLIPSE TS100: 228(W) x 517(D) x 480(H) mm, 7.5 kg
ECLIPSE TS100-F: 228(W) x 517(D) x 480(H) mm, 8.1 kg

- (3) **Optical system** CF infinity corrected optical system

- (4) **Eyepieces** 10x field number: 22
15x field number: 16

- (5) **Microscope magnification** 1x

- (6) **Diascopic illuminators** ELWD condenser: N.A. = 0.3, Physical distance = 75 mm
HMC condenser: N.A. = 0.4, Physical distance = 44 mm
Without condenser: Physical distance = 190 mm

- (7) **Phase contrast microscopy equipment** PhL, Ph1, Ph2 especially for ELWD condenser lenses

- (8) **Adjustable range for interpupillary distance** 50 mm to 75 mm

- (9) **Revolving nosepiece** 5 holes

- (10) **Focusing mechanism** Fine focus knob graduation: 2 μ m per graduation
Fine focus knob travel: 0.2 mm up or down per turn
Coarse focus knob travel: About 37.7 mm up or down per turn
Vertical travel range for revolving nosepiece:
7 mm up and 2 mm down
from the reference position (stage surface)

- (11) **Accepts episcopic-fluorescent attachment**

- (12) **For ECLIPSE TS100-F only**
 - Vertical tube: Accepts C-mount direct vertical tube attachments and photomicrographic vertical tube
 - Optical path changeover: 1) Observation 100%, Vertical tube 0%
2) Observation 0%, Vertical tube 100%



(13) Electrical specifications

- Lamp rating 6 V-30 W halogen lamp (PHILIPS 5761)
- Average lamp lifetime 100hrs.
- Output rating 6 V 5 A max.
- Input rating

Model for 100, 110 and 120V AC areas

- Input voltage: Selection from 100 V, 110 V or 120 V AC by relocating the fuse holder in the AC inlet.
- Frequency: 50-60 Hz
- Rated current: 0.8 A or less
- Voltage fluctuation: +10%
- Fuse rating: 250 V, 1 A time-lag, low-breaking type 5x20 miniature fuse x2
- Power cord: Use only the following power supply cord. Using the wrong power cord could result in danger of fire. The protection class I equipment should be connected to PE (protective earth) terminal.
 - UL listed detachable power cord set, 3-conductor grounding type SVT, No.18 AWG, 3 m long maximum, rated at 125 V AC minimum.

Model for 220, 230, 240 V AC area

- Input voltage: Selection from 220 V, 230 V or 240 V AC by relocating the fuse holder in the AC inlet.
- Frequency: 50/60 Hz
- Rated current: 0.4 A or less
- Voltage fluctuation: ±10%
- Fuse rating: 250 V, 1 A time-lag, low-breaking type 5x20 miniature fuse x2
- Power cord: Use only the following power supply cord. Using the wrong power cord could result in danger of fire. The protection class I equipment should be connected to PE (protective earth) terminal.
 - Approved according to EU/EN standards, 3 conductor grounding Type H05VV-F, 3 m long maximum, rated at 250 V AC minimum.

- Protection Class Class I

(14) Operating Environmental Conditions

- Temperature 0 to +40 C
- Humidity 85% RH max., non-condensing
- Altitude 2000 m max.
- Pollution Degree 2
- Installation category (Overvoltage category) Category 2
- Indoor use only

(15) Storage and Transport Environmental Conditions

- Temperature -20 to +60 C
- Humidity max. 90%RH (non-condensing)

(16) Conforming Standards

- The model for 100, 110, and 120V AC areas is a UL listed product.
- The model for 220,230,and 240V areas satisfies the EU IVD Directive (In vitro diagnostic medical device Directive).
(GM approved product : In vitro diagnostic medical equipment)
- The model for 220,230,and 240V areas satisfies the EU EMC Directive.(EN61326)
(The model for 100, 110, and 120V AC areas is not covered by the FCC.)



NIKON CORPORATION / 株式会社 ニコン

2-3 Marunouchi 3-chome, Chiyoda-ku, Tokyo 100-8331 Japan
〒100-8331 東京都千代田区丸の内 3-2-3 (富士ビル)

NIKON INSTECH CO., LTD. / 株式会社 ニコン インステック

Parale-Mitsui Bldg. 8, Higashida-cho, Kawasaki-ku, Kawasaki, Kanagawa, 210-0005 Japan

本社 210-0005 川崎市川崎区東田町 8 番地 ハレール三井ビルディング 13 階
札幌営業所 001-0011 札幌市北区北 11 条西 4-1-40 (すはるビル)
名古屋営業所 460-0002 名古屋市中区丸の内 3-20-17 (中外東京海上ビル)

TEL: (81-41) 223-2161 FAX: (81-41) 223-2182
電話 (011) 223-2160 FAX (011) 223-2180
電話 (011) 716-9381 FAX (011) 716-9398
電話 (052) 954-0165 FAX (052) 954-0166

●系列会社●

株式会社コーガク【大阪(本社)、京都、明石、金沢】

本社 532-0003 大阪市淀川区宮原 3-3-31 上村ニッセイビル 16 階
京都支社 606-8221 京都市左京区田中西樋ノ口町 80

電話 (06) 6394-8801
電話 (075) 781-1170

株式会社大熊商会【福岡(本社)、北九州、長崎、大分、熊本、宮崎、延岡、鹿児島】
本社 813-0031 福岡市東区多の津 1-1-1

電話 (092) 611-1111

NIKON INSTRUMENTS INC.

1300 Walt Whitman Road, Melville, NY 11747-3064, U.S.A.
Tel: +1-631-547-8500 Fax: +1-631-547-0300

NIKON INSTRUMENTS EUROPE B.V.

Schipholweg 321 P.O. Box 222, 1170 AE Badhoevedorp, The Netherlands
Tel: +31-20-44-96-222 Fax: +31-20-44-96-298