

Generator G11

Service Manual v 1.0



Ethicon
Endo-Surgery

This page should be blank.

Overview	1
Scope.....	1
Standard Conventions Used.....	1
Chapter 1 - General Information	1
Indications.....	1
Contraindications.....	1
Device Description.....	1
How Supplied.....	2
General Warnings.....	3
General Cautions.....	4
Maintenance and Repair.....	4
Customer Service.....	4
Chapter 2 - Theory of Operation	5
Generator G11 Functionality Overview.....	5
Generator G11 Theory of Operation.....	5
Main PCB I/O Diagram.....	6
Chapter 3 - Repair and Replacement Procedures	7
Bottom Cover and EPAC Removal Procedure.....	7
Main PCB Disassembly Procedure.....	8
Power Module Disassembly Procedure.....	15
Speaker Removal Procedure.....	16
Connector / Device Receptacle Removal Procedure.....	17
Front Panel Disassembly Procedure.....	18
Footswitch Receptacle Removal Procedure.....	20
Heat Sink Fan Removal Procedure.....	20
Power Cord Receptacle Removal Procedure.....	21
Chapter 4 - Generator G11 Functional Test	22
Device Description.....	22
To Verify the Energy Output of the Generator G11.....	22
Output Drive Specifications.....	23
Output Verification Procedure.....	24
Final Inspection.....	29
Generator G11 Functional Test Results.....	29
Chapter 5 - Assembly Diagram and Spare Parts List	30
Main Assembly Diagram.....	30
Spare Parts List.....	31
Cart (CRT11).....	33
Cart (CRT11) Parts List.....	33
Appendix	34
Electrical Safety Test Parameters.....	34
Schematic Diagrams.....	35
Additional Hardware Troubleshooting Information.....	42
Power versus Load Curves.....	48
System Specifications.....	51
Conformance to Standards.....	55
Symbols	56

This page should be blank.

Overview

Please read all information carefully.

Go to www.e-ifu.com for the latest version of this manual.

Failure to properly follow the instructions may lead to serious surgical consequences.

Important: This manual is designed to provide service and repair instructions for the Generator G11. It is not a reference to surgical techniques.

Harmonic® and EnSeal® are trademarks of Ethicon Endo-Surgery.

Scope

This Service Manual contains operational and diagnostic information, repair and replacement procedures and functional test information, which has been designed to assist the Service Representative in the isolation and repair of faults as well as maintenance of the Ethicon Endo-Surgery Generator G11. This documentation assumes that the service representative is familiar with the electrical and mechanical standards applicable to medical devices. This documentation also assumes that the service representative is familiar with the use of any special tools that are required to service the Generator G11.

Standard Conventions Used

The Use of Caution, Warning, and Note Statements

Information relative to the completion of a task in a safe and thorough manner will be supplied in the form of a Caution, a Warning, or a Note statement. These statements are found throughout the documentation.

These statements should be read before continuing to the next step in a procedure.

Warning: A Warning statement indicates an operating or maintenance procedure, practice, or condition that, if not strictly observed, could result in personal injury or loss of life.

Caution: A Caution statement indicates an operating or maintenance procedure, practice, or condition that, if not strictly observed, could result in damage to or destruction of the equipment.

Note: A Note statement indicates an operating or maintenance problem, practice, or condition that is necessary to accomplish a task efficiently.

Chapter 1 - General Information

Indications

The Generator G11 provides radiofrequency power to drive EnSeal electro-surgical instruments that are used during open or laparoscopic general and gynecological surgery to cut and seal vessels and to cut, grasp, and dissect tissues. In addition, the generator provides power to drive Harmonic ultrasonic surgical instruments that are indicated for soft tissue incisions when bleeding control and minimal thermal injury are desired.

EnSeal and Harmonic instruments when used with the Generator G11 have not been shown to be effective for sterilization procedures or tubal coagulation. Do not use these instruments for these procedures.

Contraindications

- The use of the Generator G11 and the attached instruments are contraindicated, when in the judgment of the physician, radiofrequency or ultrasonic surgery would be contrary to the best interest of the patient.
- The instruments are not indicated for incising bone.

Device Description

The Generator G11 supplies energy to the Harmonic and EnSeal surgical instruments. The generator uses a touchscreen display interface and has a unique receptacle port that accepts either a Harmonic or an EnSeal device. Connectors (HGA11 for Harmonic and EGA11 for EnSeal) are used to enable the generator to power legacy devices.

How Supplied

The Generator G11 is supplied in a semi-ready-to-use state. The shipping box contains the Generator G11, power cord and operator's manual. The disposable Ethicon Endo-Surgery EnSeal or Harmonic instruments are not included in this packaging and must be purchased separately. The Harmonic device connector (HGA11), EnSeal device connector (EGA11), footswitch (FSW11), cart (CRT11) and verification key (GEN11VK) are also available separately.

Illustration and Nomenclature

Front Panel of the Generator

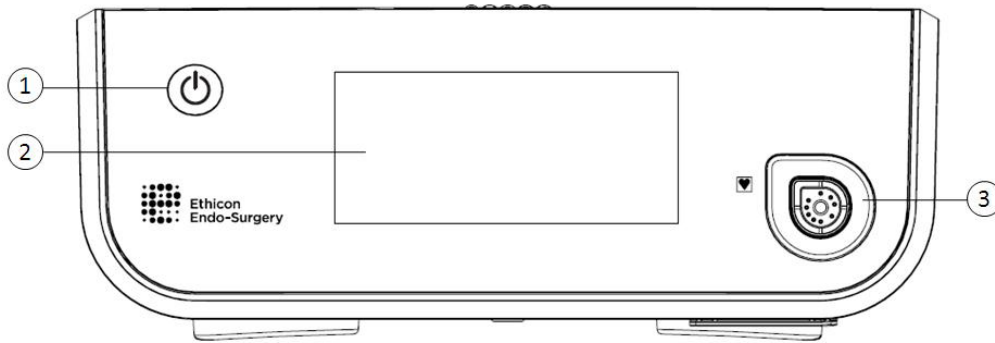

Figure 1

- | | | |
|---|------------------------------------|--|
| 1 | POWER ON/OFF SWITCH | Glows green when the generator is powered up. |
| 2 | DISPLAY/
TOUCH SCREEN | Displays system information and serves as interface for adjusting controls and settings. |
| 3 | CONNECTOR/
DEVICE
RECEPTACLE | Receptacle used to attach the connectors or devices to the generator. |

Back Panel of the Generator

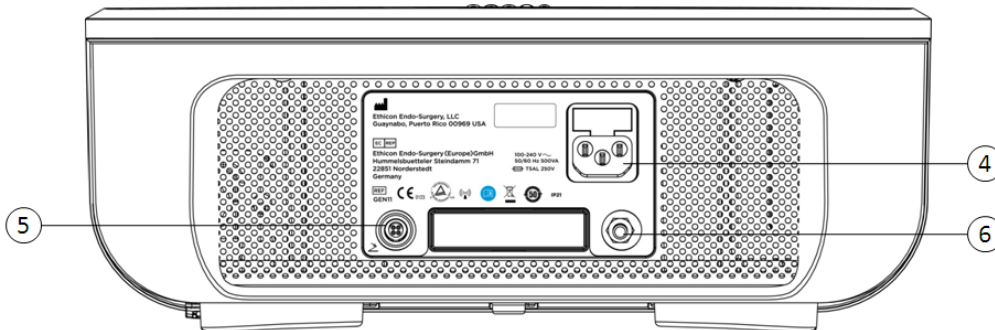

Figure 2

- | | | |
|---|--------------------------|--|
| 4 | POWER CORD
RECEPTACLE | Receptacle used to attach the power cord to the generator. |
|---|--------------------------|--|

- | | | |
|---|---------------------------------------|--|
| 5 | FOOTSWITCH
RECEPTACLE | Receptacle used to connect the footswitch to the generator. |
| 6 | POTENTIAL
EQUALIZATION
TERMINAL | Provides means for connection to a potential equalization conductor. |

Footswitch

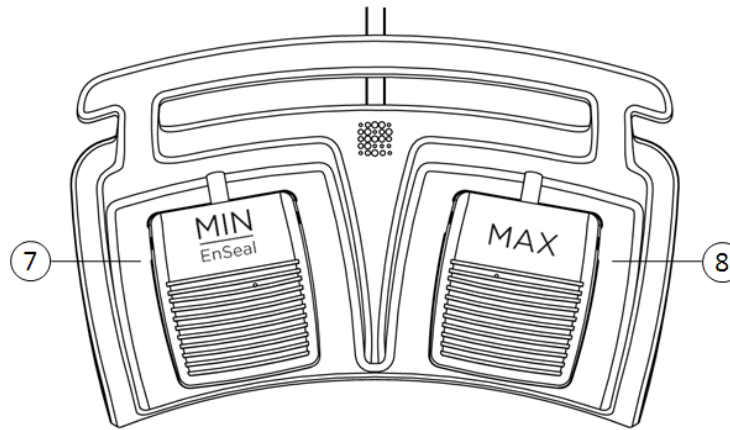

Figure 3

- | | | |
|---|-------------------|---|
| 7 | MIN (LEFT PEDAL) | Activates power for EnSeal or minimum power for Harmonic. |
| 8 | MAX (RIGHT PEDAL) | Activates maximum power for Harmonic. |

General Warnings

- Read instructions prior to energy activation, and use proper electrical safety and hospital procedures when working on the generator unit. Servicing should be performed by qualified personnel only.
- Always disconnect the device from the electrical power source before servicing.
- After removing the cover, inspect the internal components for obvious damage or foreign debris. Never remove or install any parts with the power on.
- Verify that the unit is fully operational prior to administering power output.
- High voltages may be present on surfaces inside the generator. Never touch an exposed conductive surface while the cover is removed and the unit is energized.
- This equipment is for use only by qualified medical personnel trained in the use of ultrasonic surgery or electrosurgery. Inappropriate use of the equipment by untrained medical personnel may result in hazardous electrical output.
- The Generator G11 contains components that are sensitive to electrostatic discharge (ESD). Proper ESD precautions must be taken while servicing the Generator G11. Repair work must be done at a static controlled workstation. Use an antistatic container for the transport of ESD sensitive circuit boards and components.
- Do not activate in the presence of oxidizing gases such as nitrous oxide (N₂O) and oxygen as explosion may occur.
- Non-flammable agents should be used for cleaning and disinfection wherever possible.
- Do not energize the Generator G11 in a moist environment as a shock hazard may exist. If liquids have entered the Generator G11 the unit must be returned to the manufacturer for testing prior to use.
- Do not activate the unit in close proximity to volatile solvents such as methanol or alcohol as explosion may occur.
- Avoid activation of Generator G11 adjacent to or stacked with other equipment. If adjacent or stacked use is necessary, monitor the Generator G11 and the other equipment to assure normal operation.
- Interference produced by the operation of high-frequency surgical equipment may adversely affect the operation of other electronic

Generator G11 Service Manual

medical equipment such as monitors and imaging systems.

- Activation with accessories and cables other than those specified may result in unpredictable performance, increased electromagnetic emissions, or decreased electromagnetic immunity. No customer modification of this equipment is allowed; modification of this equipment could have a negative impact on electrical safety and electromagnetic emissions.
- To avoid the risk of electric shock, this equipment must only be connected to a supply main with protective earth.
- To isolate the Generator G11 from supply mains power, disconnect the power cord either from the back panel of the generator or from the wall. Ensure access to these points are kept clear.

General Cautions

- The touch screen display of the generator is very sensitive. Do not use sharp metal objects on the touch screen.
- During servicing, when the bottom screws are removed and the device is open exercise proper caution as a hazardous condition may exist.
- Replace fuses only with the appropriate type and rating. See *System Specifications*.
- Do not sterilize the Generator G11. Sterilization will damage the unit.
- Do not restrict the openings on the bottom and the back panel of the Generator G11, as they provide the required airflow for cooling.
- If electromagnetic interference with other equipment is suspected, reorient the device or remove possible sources of interference (for example, cellular phones, radios, etc.) from the room.
- Activation of a radiofrequency device when not in a position to test energy activation may cause capacitive coupling.
- Use of the Cart (CRT11) is recommended if Generator G11 is moved out of the operating room. Maintain control of the generator and cart when moving over thresholds.
- Do not replace both the main PCB and Bezel PCB simultaneously. Doing this will compromise internal electronic information stored within the generator. Replace one board and power-up the unit prior to removal of the other board.

Maintenance and Repair

Periodic calibration is not required for Generator G11. Periodic check of output using GEN11VK is recommended per facility guidelines. Service of the Generator G11 would be required if GEN11VK shows the generator is out of tolerance. See GEN11VK instructions for use for guidance on performing the output check. For servicing activities, Generator G11 may also be returned to an authorized EES service facility at any time.

Customer Service

Warranty

This warranty and the rights and obligations hereunder shall be construed under and governed by the laws of the State of Ohio, U.S.A.

Ethicon Endo-Surgery warrants this product to be free from defects in material and workmanship under normal use and preventive maintenance for the respective warranty period shown below. Ethicon Endo-Surgery's obligation under this warranty is limited to the repair or replacement, at its option, of any product, or part thereof, which has been returned to Ethicon Endo-Surgery or its distributor within the applicable time period shown below and which examination disclosed, to Ethicon Endo-Surgery's satisfaction, to be defective. This warranty does not apply to any product, or part thereof, that has been: (1) adversely affected due to use with devices manufactured or distributed by parties not authorized by Ethicon Endo-Surgery (2) repaired or altered outside Ethicon Endo-Surgery's factory in a way so as to, in Ethicon Endo-Surgery's judgement, affect its stability or reliability, (3) subjected to improper use, negligence or accident, or (4) used other than in accordance with the design and use parameters, instructions and guidelines for the product or with functional, operational or environmental standards for similar products generally accepted in the industry.

Ethicon Endo-Surgery's products are warranted for the following periods after delivery to the original purchaser:

Generator and power cord	One (1) year, parts and labor
Footswitch	One (1) year, parts and labor
Cart	One (1) year, parts and labor

UNLESS SUPERCEDED BY APPLICABLE LOCAL LAW, THIS WARRANTY IS IN LIEU OF ALL OTHER WARRANTIES, EXPRESS OR IMPLIED, INCLUDING THE WARRANTIES OF MERCHANTABILITY AND FITNESS FOR A PARTICULAR PURPOSE, AND OF ALL OTHER OBLIGATIONS OR LIABILITIES ON THE PART OF ETHICON ENDO-SURGERY AND IS A PURCHASER'S EXCLUSIVE REMEDY. IN NO EVENT SHALL ETHICON ENDO-SURGERY BE LIABLE FOR SPECIAL, INCIDENTAL OR CONSEQUENTIAL DAMAGES INCLUDING, WITHOUT LIMITATION, DAMAGES RESULTING FROM LOSS OF USE, PROFITS, BUSINESS OR GOODWILL, OTHER THAN AS EXPRESSLY PROVIDED BY A SPECIFIC LAW. Ethicon Endo-Surgery neither assumes nor authorizes any other person to assume for it any other liability in connection with the sale or use of any of Ethicon Endo-Surgery products. There are no warranties that extend beyond the terms hereof. Ethicon Endo-Surgery reserves the right to make changes to products built

and/or sold by them at any time without incurring any obligation to make the same or similar changes on products previously built and/or sold by them.

Customer Service

Contact the Ethicon Endo-Surgery Customer Service Department or your local representative for any customer or technical support. Call 1-800-USE-ENDO (1-800-873-3636) in the U.S. only.

Chapter 2 - Theory of Operation

Generator G11 Functionality Overview

The Harmonic and EnSeal instruments that connect to the generator are surgical devices that combine high compression and low heat to quickly create strong vessel seals while generating minimal smoke, tissue char, or thermal injury.

Generator G11 Theory of Operation

The GEN11 generator is a flexible, high-power, wide band electrical surgical instrument power source. The main component of the system is a push-pull power amplifier that drives an output transformer. The output transformer is capable of stepping up the output voltage of the amplifier to a maximum of 420 Vrms @ 0.75 Arms for Harmonic instruments, or, via an intermediate tap on the secondary coil, 100 Vrms @ 3.0 Arms for RF instruments. Different instruments will utilize different ranges of the generator's output. Therefore, depending on the particular instrument used, the maximum output of the generator may not be achieved during instrument activation. The output transformer also provides the necessary isolation from earth ground (per IEC 60601-1) of the outputs that can potentially come in contact with patients. There are DC-blocking capacitors in series with the RF output, as required by medical regulation IEC 60601-2-2.

The input to the amplifier is fed by a high-speed digital-to-analog converter (DAC) that is in turn controlled by a digital signal processor (DSP) through a field-programmable gate array (FPGA). The DSP digitally controls the wave shape, amplitude, and frequency of the output signal in closed-loop fashion by monitoring the output voltage and current through two high speed analog-to-digital converters (ADC). The output voltage and current are fed to the ADC through isolation transformers that cross the patient-isolation barrier. The wave shape is generated by the DSP using direct digital synthesis within the FPGA. The amplitude is controlled on a fine scale directly through the high-speed DAC, and on a coarse scale through a lower-speed DAC which sets the full-scale range of the high-speed DAC.

Additionally, the DSP controls a switch-mode converter which provides power to the amplifier, in order to optimize the efficiency of the system. It does this by dynamically adjusting the DC output of the converter to provide just enough overhead voltage for the amplifier to produce its currently commanded output level. The DSP also sets and periodically adjusts the bias levels of the four output FET (field effect transistors) via dedicated low-speed DAC and ADC hardware. Other functions on the patient isolation side such as monitoring handswitch states, reading and writing to EEPROM (electrically erasable programmable read-only memories) contained in handpieces, instruments, and security keys, and monitoring the health of the RF DC-blocking capacitors are performed by a second FPGA on the isolated side, under control of the DSP via a bidirectional optical communication link which conforms to the IrDA (Infrared Data Association) standard.

A user interface (UI) processor controls all other user interactions with the generator including the LCD (liquid crystal display) output, capacitive touch-screen input, and audio output. The only exception to this is the capacitive touch on/off button, which is controlled by the on/off processor located on the Bezel board, and powered by separate 5 VDC standby power that is present whenever the generator is plugged in. The on/off processor controls power to the rest of the system via a power supply enable signal to the main 48 VDC power supply. A serial port and two USB (universal serial bus) ports are also provided for data transfer. These ports are not user accessible.

Main PCB I/O Diagram

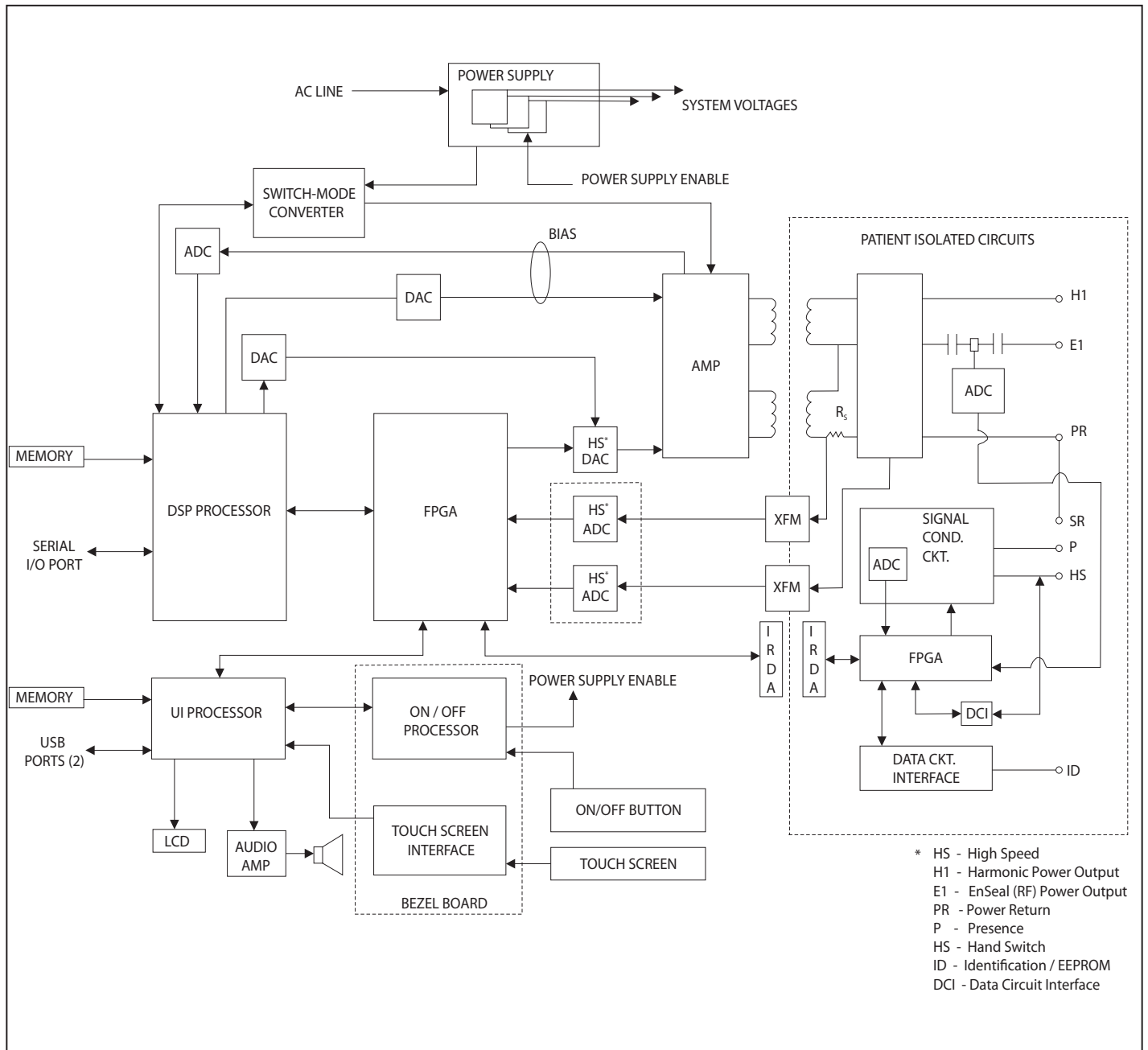

Figure 4 Main PCB I/O Diagram

Chapter 3 - Repair and Replacement Procedures

Bottom Cover and EPAC Removal Procedure

1. Turn the unit upside down.



Figure 5

2. Remove the four mounting screws as shown in the image.

Note: During disassembly and assembly, metal shavings may be generated when screwing and unscrewing screws. Be sure to clean up any metal shavings.

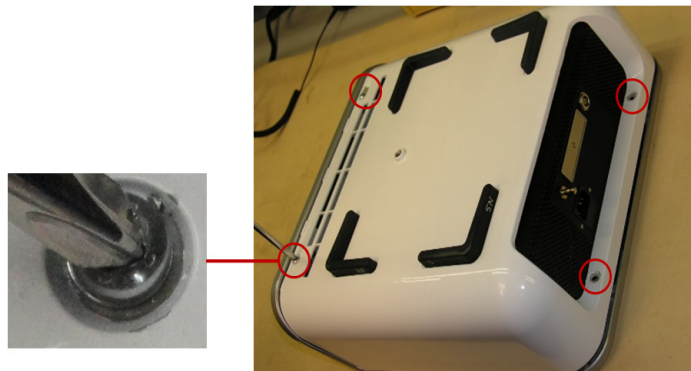

Figure 6

3. Remove the bottom enclosure by sliding it backwards.



Figure 7

4. Separate the bottom EPAC.

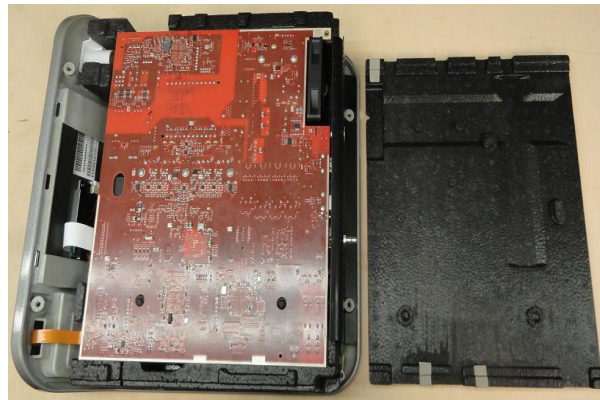

Figure 8

Main PCB Disassembly Procedure

Note: The main PCB contains information that is electronically stored. Once a new PCB has been installed in the generator and powered up, it cannot be used in another generator. Please be sure you want to replace the PCB before installing the new one.

Caution: Do not replace both the main PCB and Bezel PCB simultaneously. Doing this will compromise internal electronic information stored within the generator. Replace one board and power-up the unit prior to removal of the other board.

1. Disconnect the J4 DC Connector and Power Grounding Cable as shown.

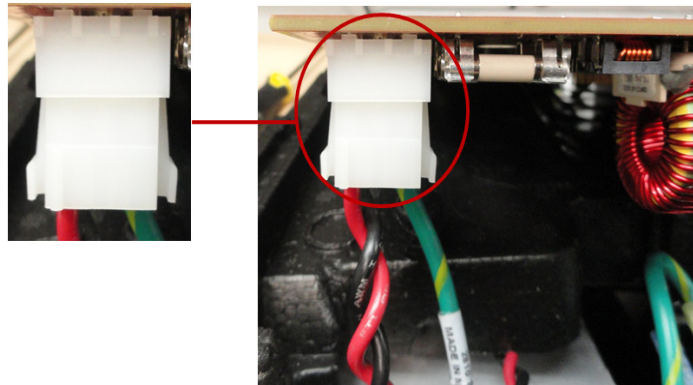

Figure 9

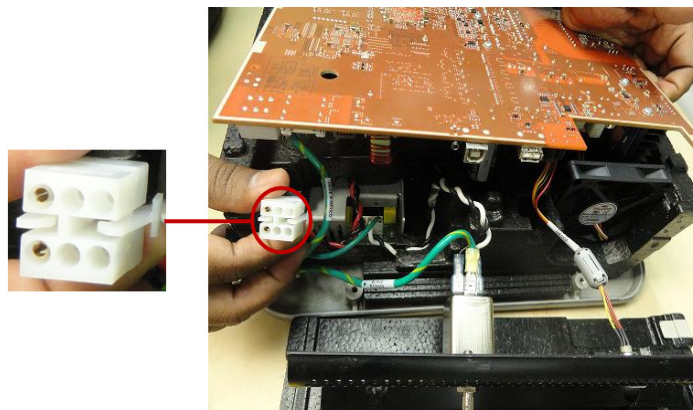

Figure 9a

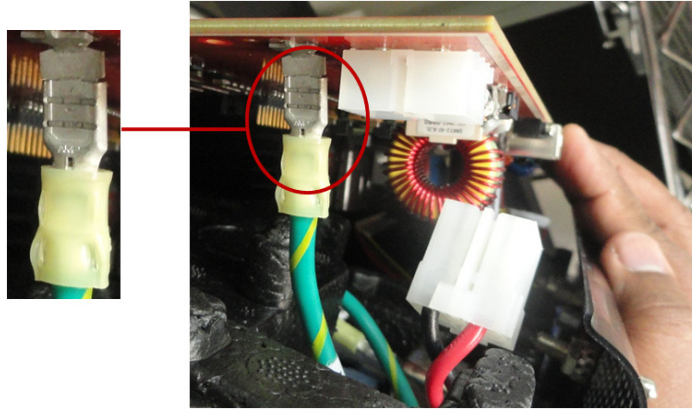

Figure 9b

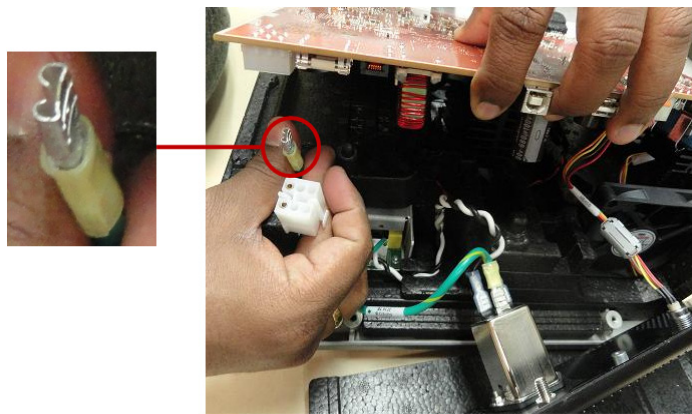

Figure 9c

2. Disconnect the following as shown in the images:
 - J5 Footswitch

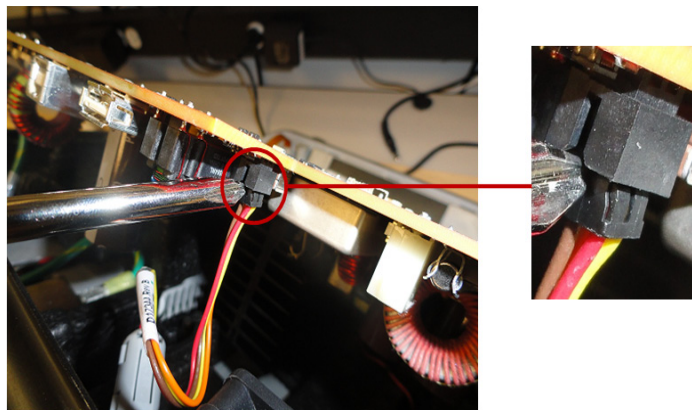

Figure 10

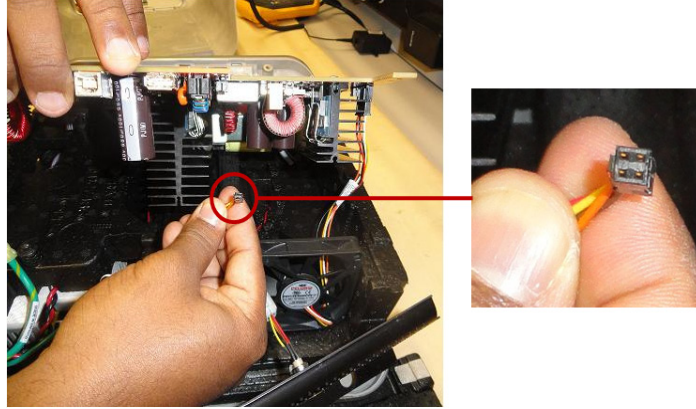

Figure 10a

- J8 Enclosure Fan

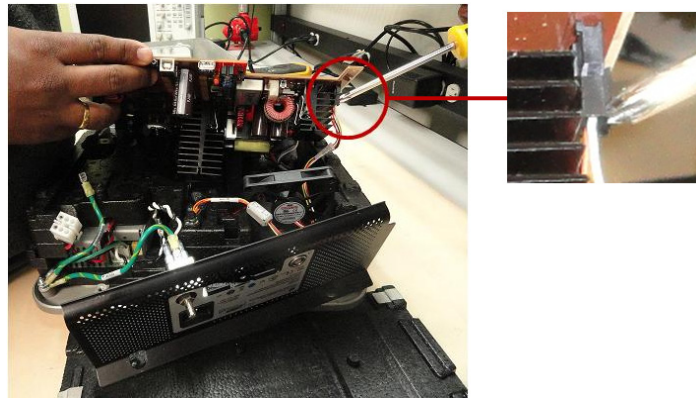

Figure 11

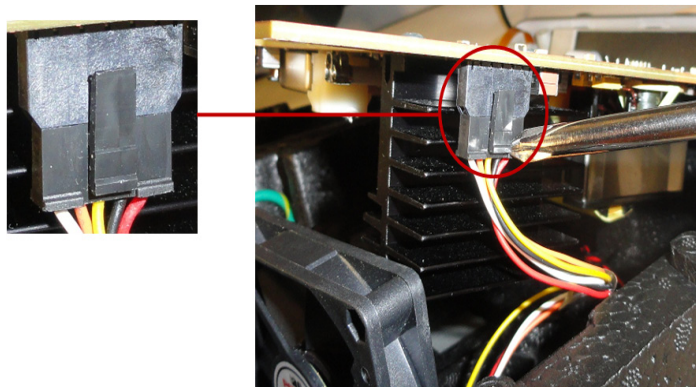

Figure 11a

3. Separate the PCB from the generator.

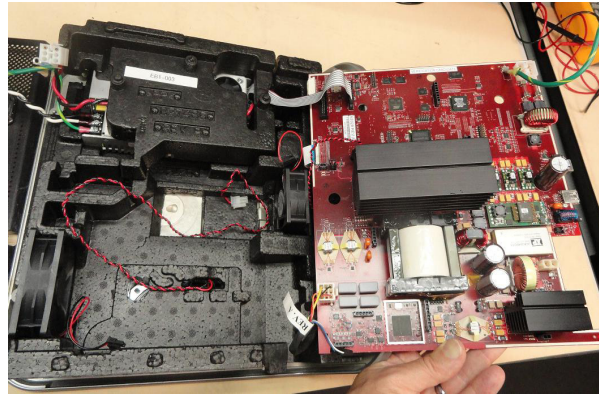

Figure 12

4. Remove the following electrical connections and route wires:
 - J21 Power Supply IO

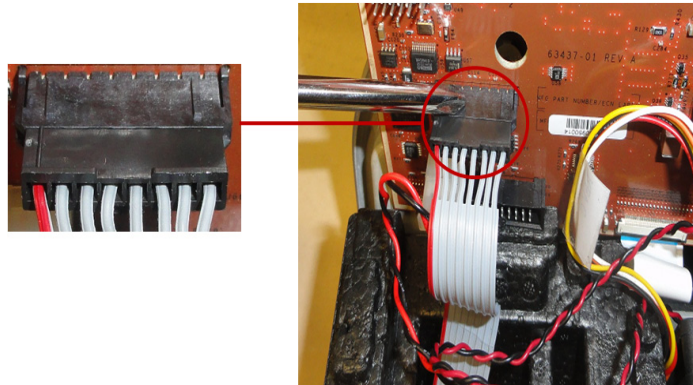

Figure 13

- J23 Speaker

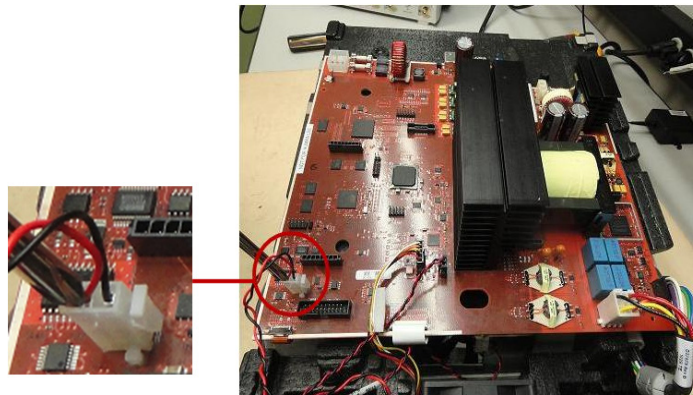

Figure 14

- J27 Heat sink Fan

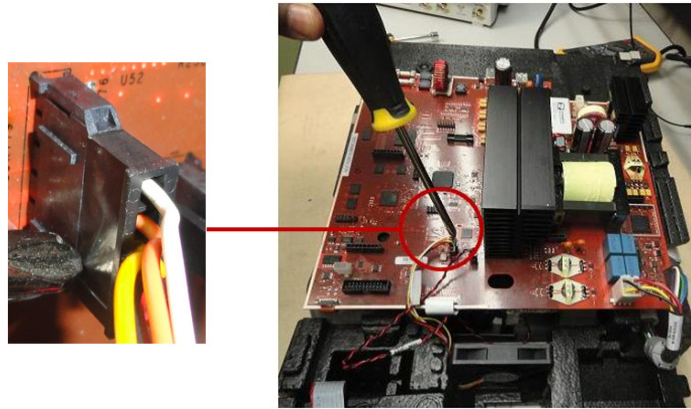

Figure 15

- J25 Backlight

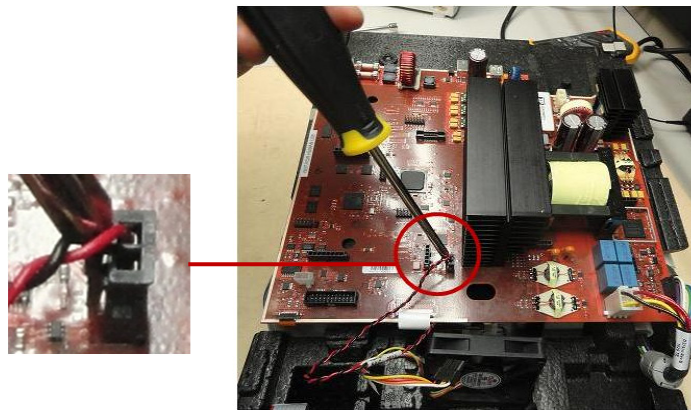

Figure 16

- J28 Receptacle 9 pin

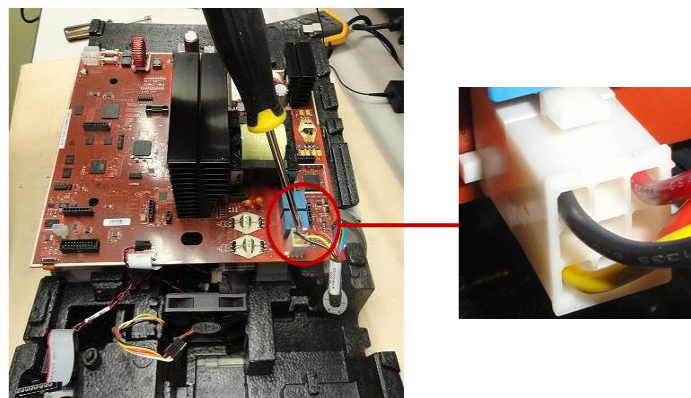

Figure 17

- J24 Receptacle 5 pin

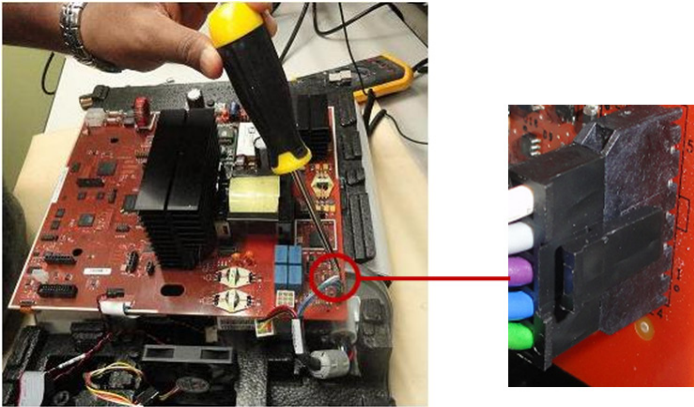

Figure 18

- J29 LCD Flat Connector

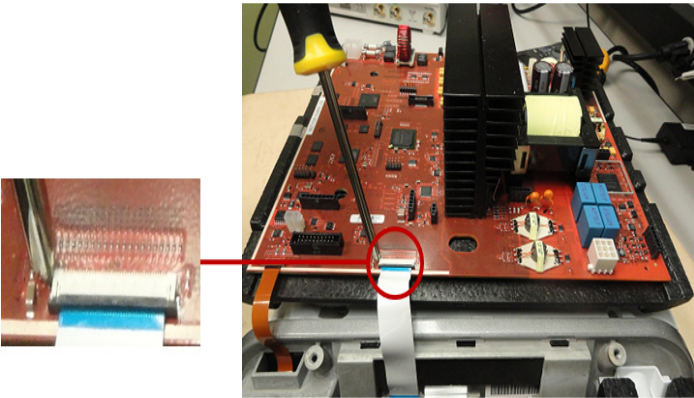

Figure 19

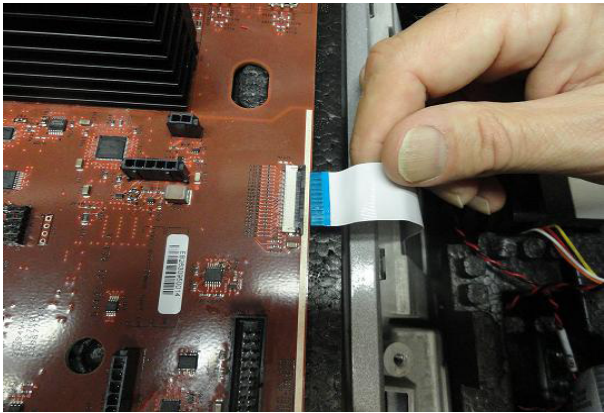

Figure 19a

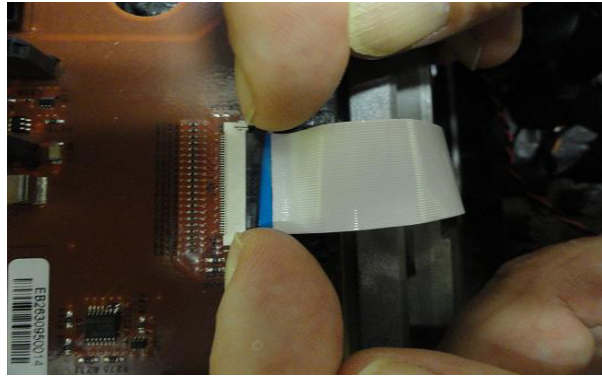

Figure 19b

- J30 Bezel Flat Connector

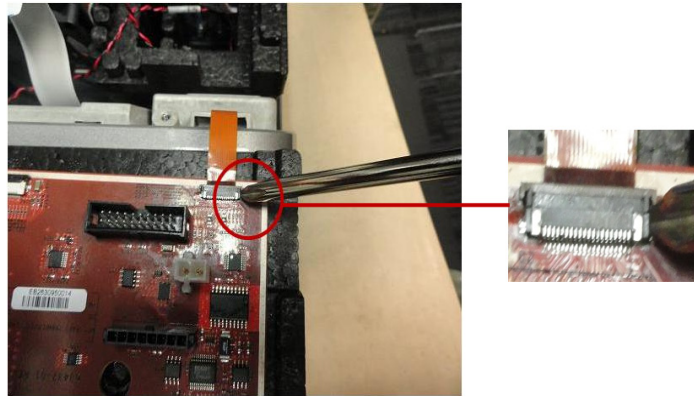

Figure 20

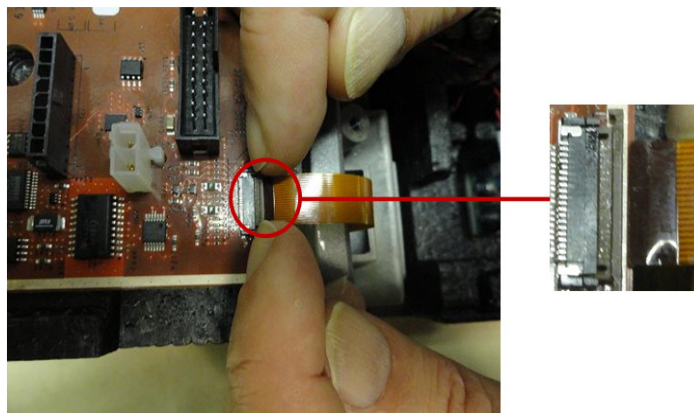

Figure 20a

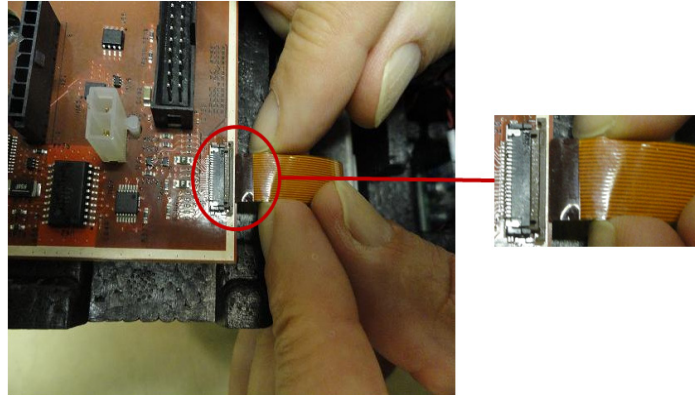

Figure 20b

Power Module Disassembly Procedure

1. Remove the power module ground connector from the module terminal.

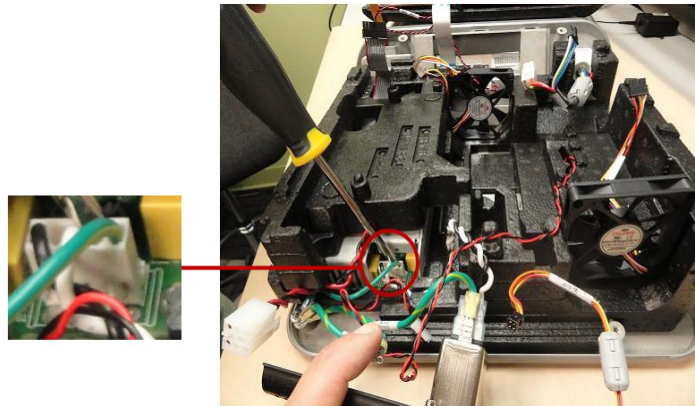

Figure 21

2. Take out the power module from the unit.

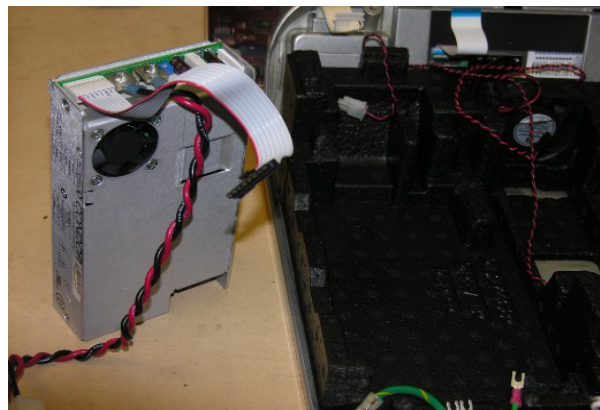

Figure 22

Speaker Removal Procedure

1. Remove the top EPAC from the top chassis.

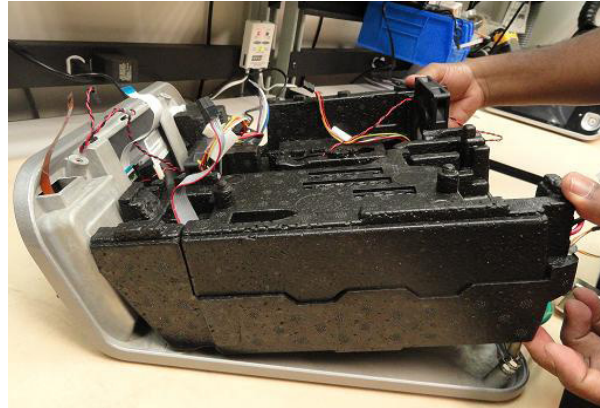

Figure 23

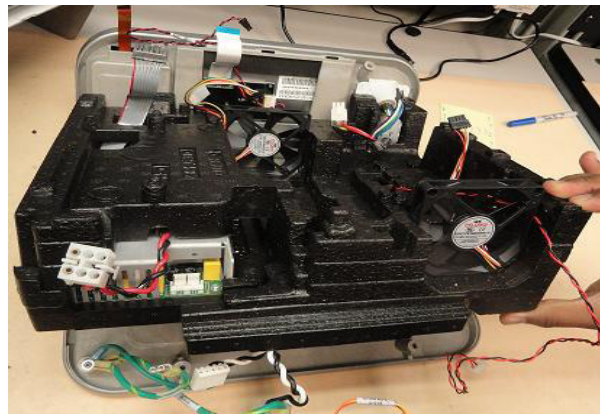

Figure 23a



Figure 23b

2. Pull out the speaker using flat head screw driver.

Note: The speaker is stuck to the top with tape. It is separated using a flat head screw driver.

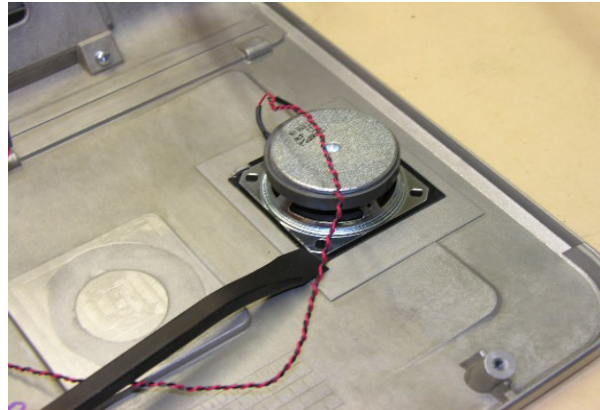

Figure 24

Connector / Device Receptacle Removal Procedure

1. Remove the side screws of the Connector / Device Receptacle with a T15 Torx.

Note: During disassembly and assembly, metal shavings may be generated when screwing and unscrewing screws. Be sure to clean up any metal shavings.

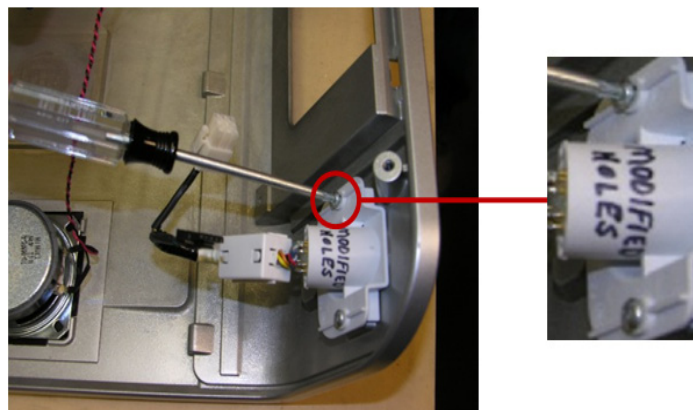

Figure 25

2. Separate the Connector / Device Receptacle from the top chassis.

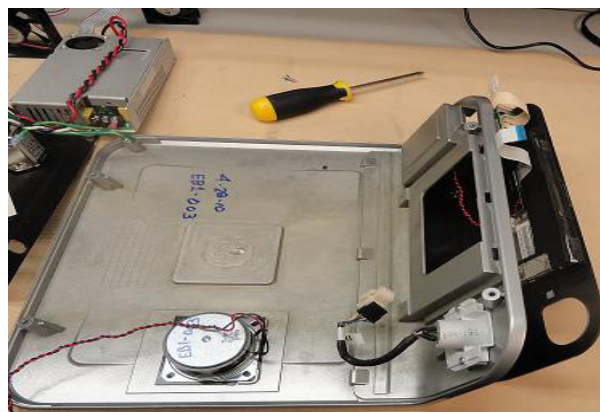

Figure 26

Front Panel Disassembly Procedure

1. Remove the two screws from the top chassis.

Note: During disassembly and assembly, metal shavings may be generated when screwing and unscrewing screws. Be sure to clean up any metal shavings.

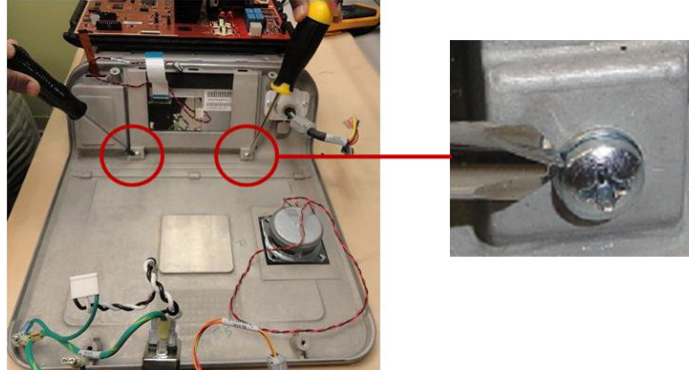

Figure 27

2. Separate the Bezel assembly from the top enclosure and LCD cables as shown below.



Figure 28

3. Remove gasket and LCD from the Bezel.



Figure 29

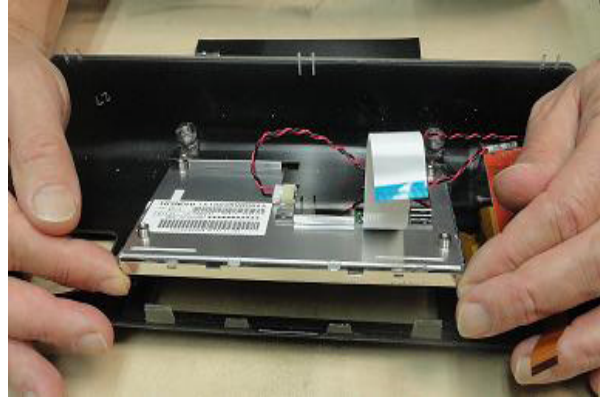

Figure 29a

4. Separate the LCD gasket from the Bezel.



Figure 30

5. Disconnect the Bezel PCB cables.

Note: The Bezel PCB contains information that is electronically stored. Once a new Bezel PCB has been installed in the generator and powered up, it cannot be used in another generator. Please be sure you want to replace the Bezel PCB before installing the new one.

Caution: Do not replace both the main PCB and Bezel PCB simultaneously. Doing this will compromise internal electronic information stored within the generator. Replace one board and power-up the unit prior to removal of the other board.

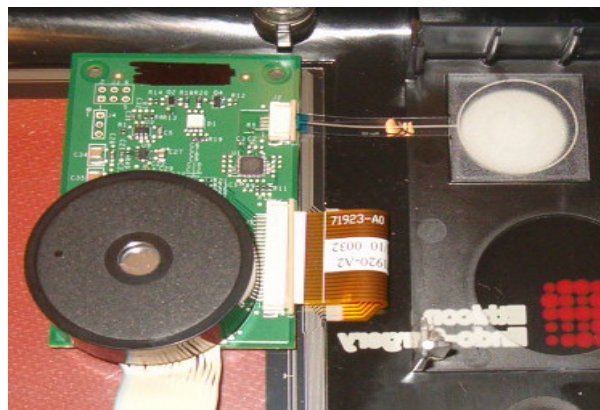

Figure 31

6. Take out the PCB from the Bezel.

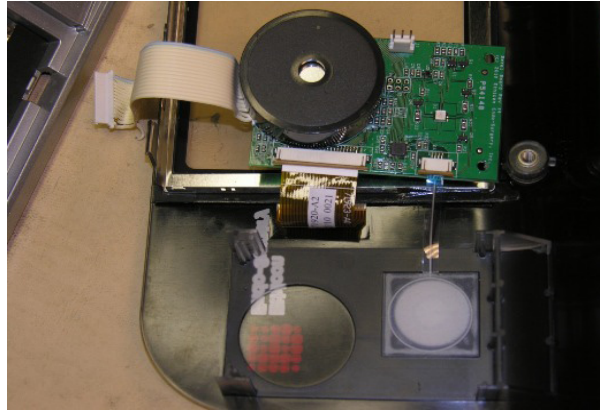

Figure 32

Footswitch Receptacle Removal Procedure

1. Loosen the nut and separate the footswitch receptacle from the back panel.



Figure 33

Heat Sink Fan Removal Procedure

1. Separate the heatsink fan and the main board fan from the EPAC slots.

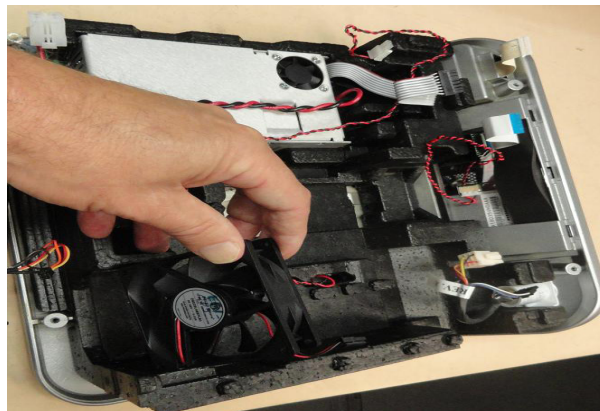

Figure 34

Power Cord Receptacle Removal Procedure

1. Remove the side screws and separate the power cord receptacle from the back panel.

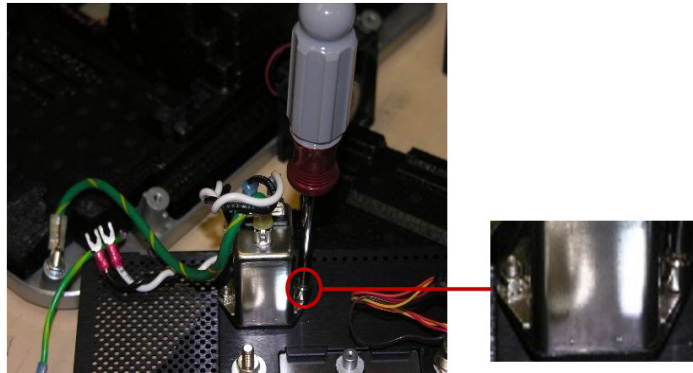

Figure 35

2. Remove the set screw and washer on the power entry ring terminal.

Note: Power Entry Module to the Chassis Ground must go on top of a washer and then be immediately backed up by a nut with captive washer. This is the protective earth ground and this configuration is regulated. The remaining two terminals can go on in either order and then they must be backed up with the nut with captive washer.



Figure 36

Chapter 4 - Generator G11 Functional Test

Device Description

The GEN11 Verification Key (GEN11VK) is a tool to verify power output by the Generator G11 (GEN11) in either Harmonic or EnSeal mode. The GEN11VK is for use only by medical personnel trained in medical and electrical equipment operation. Use the GEN11VK per facility guidelines to verify the output of the Generator G11.

Required Equipment for Procedure

The following are not included in the generator packaging:

- Verification key (GEN11VK)
- Footswitch (FSW11)
- A Harmonic Handpiece (HP054, HPBLUE) with a hand activated instrument and corresponding torque wrench.
- An EnSeal instrument.
- A damp chamois or paper towel.
- A wax block or cup of water.
- Standard pair of test cables to connect the Electrosurgical Analyzer to the verification key.

Note: Test cables length should be equal to or shorter than 3 feet (36 inches/1 meter) in length.

- Standard Electrosurgical Analyzer (Example: Model 454A by DNI NEVADA Inc. / Fluke Biomedical)

Note: Power measurement accuracy of the Electrosurgical Analyzer should be equal to or lower than $\pm 10\%$ at both Harmonic and EnSeal drive frequencies ($55.5 \text{ KHz} \pm 5 \text{ KHz}$ and $330 \text{ KHz} \pm 3 \text{ KHz}$ respectively).

Note: Refer to Table 1 for resistor values required for the output verification, if not available within the Electrosurgical analyzer, these resistors need to be connected to the auxiliary connection of the Electrosurgical analyzer:

Table 1 – Required Resistor Values for Output Verification

Load Resistor Value (Ohms)	Minimum Load Resistor Power Rating (Watts)
50	150
100	100
150	25
200	50
650	100
1250	50

To Verify the Energy Output of the Generator G11

The Output Verification function of the GEN11VK verifies that Harmonic or EnSeal power outputs are within required specifications for the Generator G11. In Harmonic mode, perform output verification by driving two predetermined output current-drive levels into known resistors. In EnSeal mode, perform output verification by driving a predetermined output power curve into known resistors.

If Generator G11 exhibits power output outside of the acceptable ranges, contact your local representative for instructions. For repair, Generator G11 may also be returned to an authorized Ethicon Endo-Surgery service facility at any time.

Note: EnSeal is used to describe instruments driven by radiofrequency (RF) power.

Output Drive Specifications

The maximum outputs listed in the following tables represent test points for output verification of the generator. The outputs are not the maximum that the generator is capable of producing. Instead, the test points reflect loads that are available from off-the-shelf Electrosurgical Analyzers. Not all of these outputs are currently available clinically. Access to these outputs is controlled by the GEN11VK, which places the generator in verification-only mode.

Table 2 – Harmonic Maximum Output Drive Specifications

Activation Switch	Current Amps (RMS)	Voltage VAC (RMS)	Power (Watts)
MIN / EnSeal	0.2	250	50
MAX	0.4	250	100

Table 3 – EnSeal Maximum Output Drive Specifications

Activation Switch	Current Amps (RMS)	Voltage VAC (RMS)	Power (Watts)
MIN / EnSeal	3	100	135

Note: During EnSeal output verification, verify only the MIN / EnSeal activation.

Output Verification Procedure

1. Turn off the Generator G11.
2. Connect the footswitch (FSW11) to the footswitch receptacle on the back panel of the generator.
3. Connect the output verification key (GEN11VK) to the Generator G11 front panel receptacle.

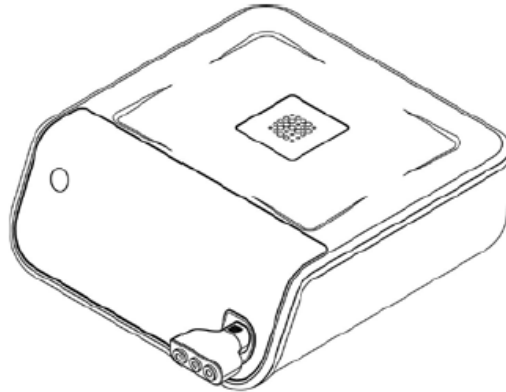

Figure 37 GEN11 Verification Key

4. Connect two standard test leads to the Harmonic output of the verification key.

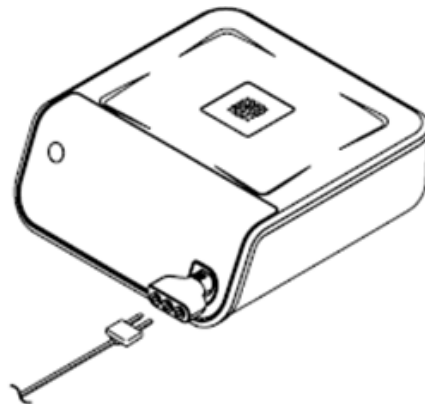

Figure 38 Standard Test Leads

Note: The following figure illustrates the three active connections of the verification key when plugged into the Generator G11:

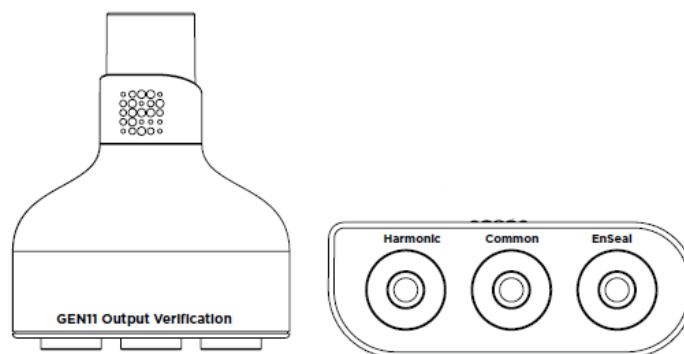

Figure 39 Three Active Connections

5. Connect the other end of the standard test cables to the Electrosurgical Analyzer.
6. Power-up the Generator G11. After the power-up sequence, the following screen should display on the touch screen.

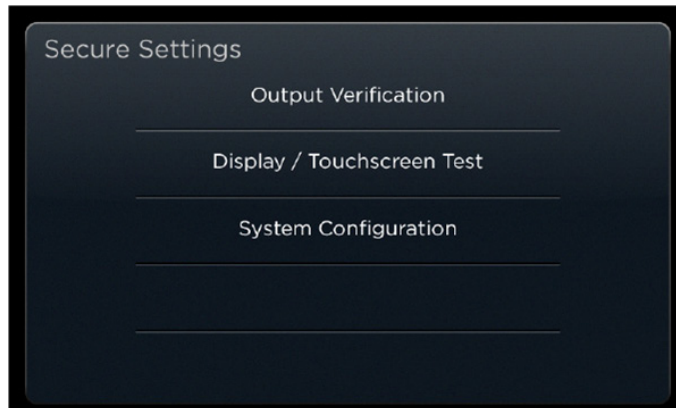

Figure 40 Secure Settings

7. Select “Output Verification” on the touch screen, as shown below.



Figure 41 Output Verification

To Verify Harmonic Power Output

8. The following screen will appear:

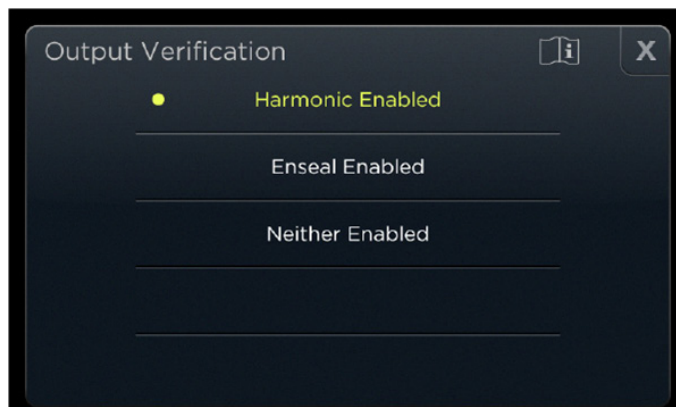

Figure 42 Harmonic Enabled

Warning: Ensure the mode selected on the touchscreen is the same as the mode plugged into on the GEN11VK. Incorrectly plugging cables into wrong receptacles will result in incorrect output power readings.

9. Set the Electrosurgical Analyzer load resistor to 150 Ohms.
10. Activate the Harmonic MIN output by pressing the MIN / EnSeal foot pedal on the footswitch assembly.
11. While activating the MIN output, measure the output power and record in Table 4 - Harmonic MIN Output Power Verification.
Note: All tables referred to in this procedure are provided at the end of this section.
12. Release the MIN / EnSeal foot pedal on the footswitch assembly to de-activate the Harmonic MIN output.
13. Repeat steps 9 - 12 with a 650 Ohm resistor and a 1250 Ohm resistor.
14. Set the Electrosurgical Analyzer load resistor to 150 Ohms.
15. Activate the Harmonic MAX output by pressing the MAX foot pedal on the footswitch assembly.
16. While activating the MAX output, measure the output power and record in Table 5 - Harmonic MAX Output Power Verification.
17. Release the MAX foot pedal on the footswitch assembly to de-activate the Harmonic MAX output.
18. Repeat steps 14 - 17 with a 650 Ohm resistor and a 1250 Ohm resistor.
19. Using the touch screen, select Neither Enabled, as shown below.

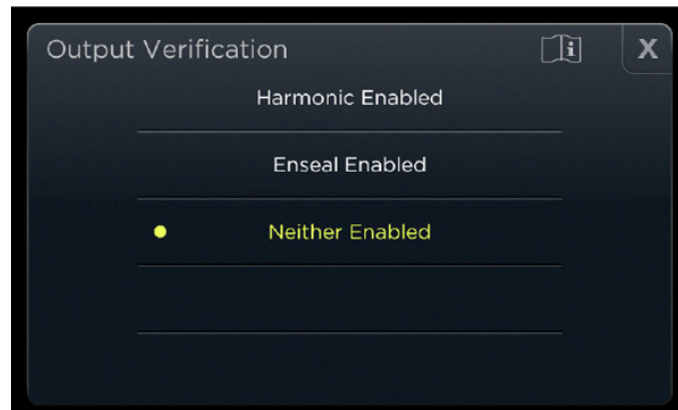

Figure 43 Neither Enabled

20. Unplug the standard test cables from the Harmonic output of the verification key.
21. Connect the standard test cables to the EnSeal output of the verification key.

To Verify EnSeal Power Output

22. Using the touch screen, select "EnSeal Enabled", as shown below.

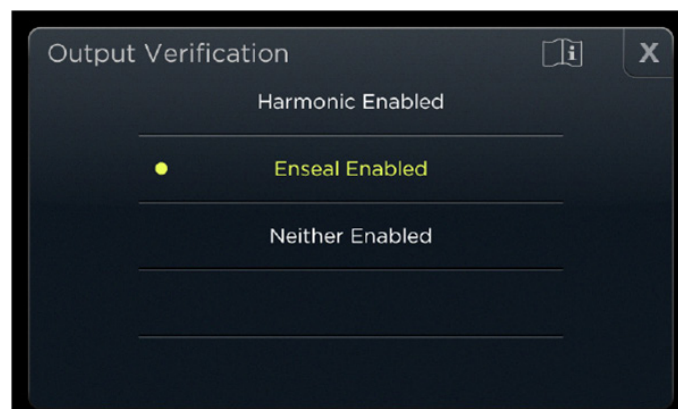

Figure 44 EnSeal Enabled

Warning: Ensure the mode selected on the touchscreen is the same as the mode plugged into on the GEN11VK. Incorrectly plugging cables into wrong receptacles will result in incorrect output power readings.

23. Set the Electrosurgical Analyzer load resistor to 50 Ohms.
24. Activate the EnSeal output of the generator by pressing the MIN / EnSeal foot pedal on the footswitch assembly.
25. While activating the EnSeal output, measure the output power and record in Table 6 - EnSeal Output Power Verification.
26. Release the MIN / EnSeal foot pedal on the footswitch assembly to de-activate the EnSeal output.
27. Repeat steps 23 - 26 with a 100 Ohm resistor and a 200 Ohm resistor.
28. Power the GEN11 generator down.
29. Remove the standard test cables and verification key.
30. Examine the recorded values for the Harmonic and EnSeal outputs, compare to acceptable minimum / maximum limits and record the PASS / FAIL column.

Table 4 – Harmonic MIN Output Power Verification

	Load Resistor (Ohms)	Target Power (Watts)	Minimum Power Limit (Watts)	Measured Power (Watts)	Maximum Power Limit (Watts)	Pass / Fail
Harmonic MIN	150	6	4.50		7.70	
	650	26	22.23		30.03	
	1250	50	42.75		57.75	

Table 5 – Harmonic MAX Output Power Verification

	Load Resistor (Ohms)	Target Power (Watts)	Minimum Power Limit (Watts)	Measured Power (Watts)	Maximum Power Limit (Watts)	Pass / Fail
Harmonic MAX	150	24	20.52		27.72	
	650	100	85.50		115.50	
	1250	50	42.75		57.75	

Table 6 – EnSeal Output Power Verification

	Load Resistor (Ohms)	Target Power (Watts)	Minimum Power Limit (Watts)	Measured Power (Watts)	Maximum Power Limit (Watts)	Pass / Fail
EnSeal	50	135	115.42		155.92	
	100	100	85.50		115.50	
	200	50	42.75		57.75	

Test Operator: _____

Name

Signature

Date

Generator Serial Number: _____

Note: The tolerances built into the minimum and maximum power limits in the Harmonic and EnSeal Output Power Verification Tables account for the generator output tolerances and an Electrosurgical Analyzer with a power measurement accuracy of $\pm 10\%$.

Touch Screen Test (Optional)

Perform the optional touch screen test, if the problem is suspected with touch screen.

1. Select the test.
2. Follow the on-screen prompt.
3. Each cell should change to a lighter shade when it is touched. If any cell does not change when touched, then the generator needs to be serviced.
4. After completing the test, remove the verification key. The generator will restart automatically.

Final Inspection

Test each generator to ensure it is functional. Record results on data sheet (see sample below). Testing will include the following:

1. Plug in power cord to generator and to wall outlet. Power on the generator using the on/off button. Ensure that the device powers on.
2. Ensure that audible beep is heard and generator power switch glows green.
3. Ensure that the LCD is functioning.
4. Touch multiple areas of the touch screen to verify that it is functioning and changes according to touch prompts.
5. Check the LCD image by selecting different options in the touch screen.
6. Plug in footswitch to receptacle in Rear Air Plate and ensure that the generator is activated by the footswitch.
7. Plug in Harmonic device (handpiece with instrument) into the generator. Activate the instrument using footswitch for 2 seconds to run test. (If using shears, keep the jaws open.) Ensure that generator is activating by verifying with wax block or water.
8. Plug in EnSeal device into the generator. Clamp the device jaws onto a piece of damp chamois or paper towel. Activate EnSeal instrument using the footswitch. Ensure that generator is activated by observing water evaporation.
9. Plug in Harmonic device (handpiece with instrument) into the generator. Activate the instrument using handswitch for 2 seconds to run test. (If using shears, keep the jaws open.) Ensure that generator is activating by verifying with wax block or water.
10. Plug in EnSeal device into the generator. Clamp the device jaws onto a piece of damp chamois or paper towel. Activate EnSeal instrument using the handswitch. Ensure that generator is activated by observing water evaporation.
11. During the generator activation, ensure the speaker is functioning.
12. During the generator activation, ensure that fans are functioning.

Generator G11 Functional Test Results

Device Serial Number: _____

Output Verification Passes	Test	Pass	Fail
1	On/Off Button Activates		
2	Audible Speaker Beeps / Power switch glows green		
3	LCD Powers up		
4	Touch Screen Functions		
5	LCD Image Changes		
6	Footswitch activates the generator		
7	Generator activates a Harmonic load with footswitch		
8	Generator activates an EnSeal load with footswitch		
9	Generator activates a Harmonic load with handswitch		
10	Generator activates an EnSeal load with handswitch		
11	Speaker Function		
12	Fans Function		

Test Operator: _____

Name	Signature	Date
------	-----------	------

Spare Parts List

The following reference numbers correspond to the numbers in *Figure 45 - Main Assembly Diagram*.

Item No.	Part Number	Description
2	EE01-63095	Main PCB Assembly
3	EE65-00002	7" LCD Display (Hitachi)
4	EE99-00007	Power Entry Module, Fused 5A
5	EE70-00001	Power Supply, 48V 400W (Condor)
6	EE40-00005	Fuse 5A 250V Slow burn 5 x 20mm (Power Entry)
7	EE45-00036	M3 Nut with captive washer (Power Entry) (See NOTE 3)
8	EE20-00021	Adapter Plate
9	EE20-00022	Enclosure Bottom Deco Assembly
10	EE20-00025	Enclosure Top Deco Assembly
11	EE15-00031	POAG-S6-15 Equipotential
12	EE45-00003	F / M 6 Lock Washer (Equipotential)
13	EE45-00002	MUO.5D / M6 Nut (Equipotential) (See NOTE 4)
14	EE45-00042	8-32 x 1/2" PH Phillips screw w / Washer (See NOTE 1)
15	EE45-00004	M3.5 x 12mm Threadforming Torx Plus Screw (Receptacle) (See NOTE 2)
16	EE45-00048	8-32 x 1.25" Set screw (Earth Ground)
17	EE45-00049	8-32 Nut w / Captive Washer (Earth Ground)
18	EE20-00019	USB Cover Plate Assembly
19	EE20-00020	Rear Air Plate Assembly
20	EE20-00014	Bezel / ITO Assembly
21	EE01-63096	Bezel PCB Assembly
22	EE20-00015	Bonding Gasket Display Front
23	EE20-00016	LCD Gasket Display Rear
24	EE20-00017	Foam Pad PCB On Off
25	EE00-00009	EPAC Top (Condor)
26	EE99-00010	Bottom EPAC and Tape Sub-Assembly
27	EE00-00004	EPAC Middle (Condor)
28	EE20-00018	Foot Enclosure
29	EE60-00001	Main Label
31	EE60-00016	Serial Number Label with Graphics only
32	EE60-00004	Magnetic Rep Label
33	EE60-00006	Patent Label
34	EE05-00001	Flex Cable Assembly, Main Board to LCD
35	EE05-00002	Cable Assembly, Power Entry Module to Power Supply
36	EE05-00003	Cable Assembly, Backlight to Main Board
37	EE05-00004	Cable Assembly, Power Entry Module to Chassis Ground
38	EE05-00005	Cable Assembly, Power Supply to Main Board
39	EE05-00007	Cable Assembly, Power Supply I / O to Main Board
40	EE05-00008	Cable Assembly, Enclosure / Heatsink Fan to Main Board
41	EE05-00010	Cable Assembly, Footswitch to Main Board (See NOTE 5)
42	EE05-00011	Cable Assembly, Receptacle to Main Board
43	EE38-00002	Speaker (8 Ohm)

Generator G11 Service Manual

Item No.	Part Number	Description
44	EE00-00002	Speaker Adhesive Pad
45	EE20-00026	Bezel Gutter Gasket
46	EE05-00014	Cable Assembly, Main Board to Chassis Ground
47	EE30-00009	Ferrite, Footswitch
48	EE30-00008	Ferrite, Receptacle
49	EE45-00050	#8 Internal - Tooth Lock Washer
50	EE99-0015	Damping Trim
N/A	EE40-00009	Fuse, 2 Amp (Main Board)
N/A	EE40-00008	Fuse, 8 Amp (Main Board)
N/A	EE00-00010	Foam End Cap - Left
N/A	EE00-00011	Foam End Cap - Right
N/A	EE05-00012	Power Cord 13 Amps, 125 V, 15 Feet
N/A	EE00-00013	Anti-Static Bag 20" x 24"
N/A	EE00-00014	Corrugated Box for GEN11

NOTE:

Note No.	Description
1	Fasteners shown should be tightened to a 7.0 ± 1 in / lb Torque setting.
2	Receptacle connector fasteners should be tightened to a 14.0 ± 1.5 in / lb Torque setting only. When initially forming threads use 27.0 ± 3 in / lb Torque setting.
3	Power Entry Module fasteners should be tightened to an 8.0 ± 1 in / lb Torque setting.
4	Equipotential fastener should be tightened to a 19.0 ± 2 in / lb Torque setting.
5	Footswitch connector fastener should be tightened to a 9.0 ± 1 in / lb Torque setting.
6	USB cover plate fastener should be tightened to a 3.0 ± 1 in / lb Torque setting.

Cart (CRT11)



Figure 46 - Cart

Cart (CRT11) Parts List

Item No.	Part Number	Description
1	ETH2600	Caster, Locking (2 Places)
2	ETH2660	Caster, Swivel (2 Places)
3	ETH2700	Device Retention Screw
4	ETH2800	Grommet (2 Places)
N/A	ETH2900	This is the full hardware kit that includes 8 screws, flat washers and lock washers for the upright as well as the 4 lock washers for the casters. *All screws must be torqued to 70-80 in / lb.

Appendix

Electrical Safety Test Parameters

Electrical safety tests are recommended to be performed on a regularly scheduled basis in accordance with facility guidelines. The following test processes and parameters are recommended in accordance with the safety standards specified in this manual.

Table 1 – Ground Bond Test

Test Parameter	Test Name / Description	UCL	LCL	Units
Consult local requirements	Total Resistance	0.100	0.001	Ohms

Table 2 – Patient Applied Part Circuit Dielectric Test

Note: It is recommended only if a service or repair to the patient connected circuit is made.

Test ID	Test Name / Description	UCL	LCL	Units
4000 V	Patient Applied Part Dielectric	10.0	0.15	mA

Table 3 – Chassis to mains Circuit Dielectric

Note: It is recommended only if a service or repair to the AC line circuit is made.

Test ID	Test Name / Description	UCL	LCL	Units
1500 V for 60 sec or 1776 V for 1 sec	Chassis-to-Mains Circuit Dielectric	10.0	0.5	mA

Table 4 – Earth Leakage Current (Optional, not required for servicing the device)

Test Parameter	Test Name / Description	UCL	LCL	Units
Consult local requirements	Earth Current Leakage - Normal	300	0.0	μA
Consult local requirements	Earth Current Leakage – Reverse	300	0.0	μA
Consult local requirements	Earth Current Leakage Single Fault – Normal	1.0	0.0	mA
Consult local requirements	Earth Current Leakage Single Fault – Reversed	1.0	0.0	mA

Table 5 – Patient Leakage Current from Applied Part to Earth (Optional, not required for servicing the device)

Test Parameter	Test Name / Description	UCL	LCL	Units
Consult local requirements	Patient Leakage Current - Normal	10	0.0	μA
Consult local requirements	Patient Leakage Current – Reverse	10	0.0	μA
Consult local requirements	Patient Leakage Current Single Fault – Normal	50.0	0.0	μA
Consult local requirements	Patient Leakage Current Single Fault – Reversed	50.0	0.0	μA

Schematic Diagrams

Schematic - Audio DAC and Miscellaneous Connectors

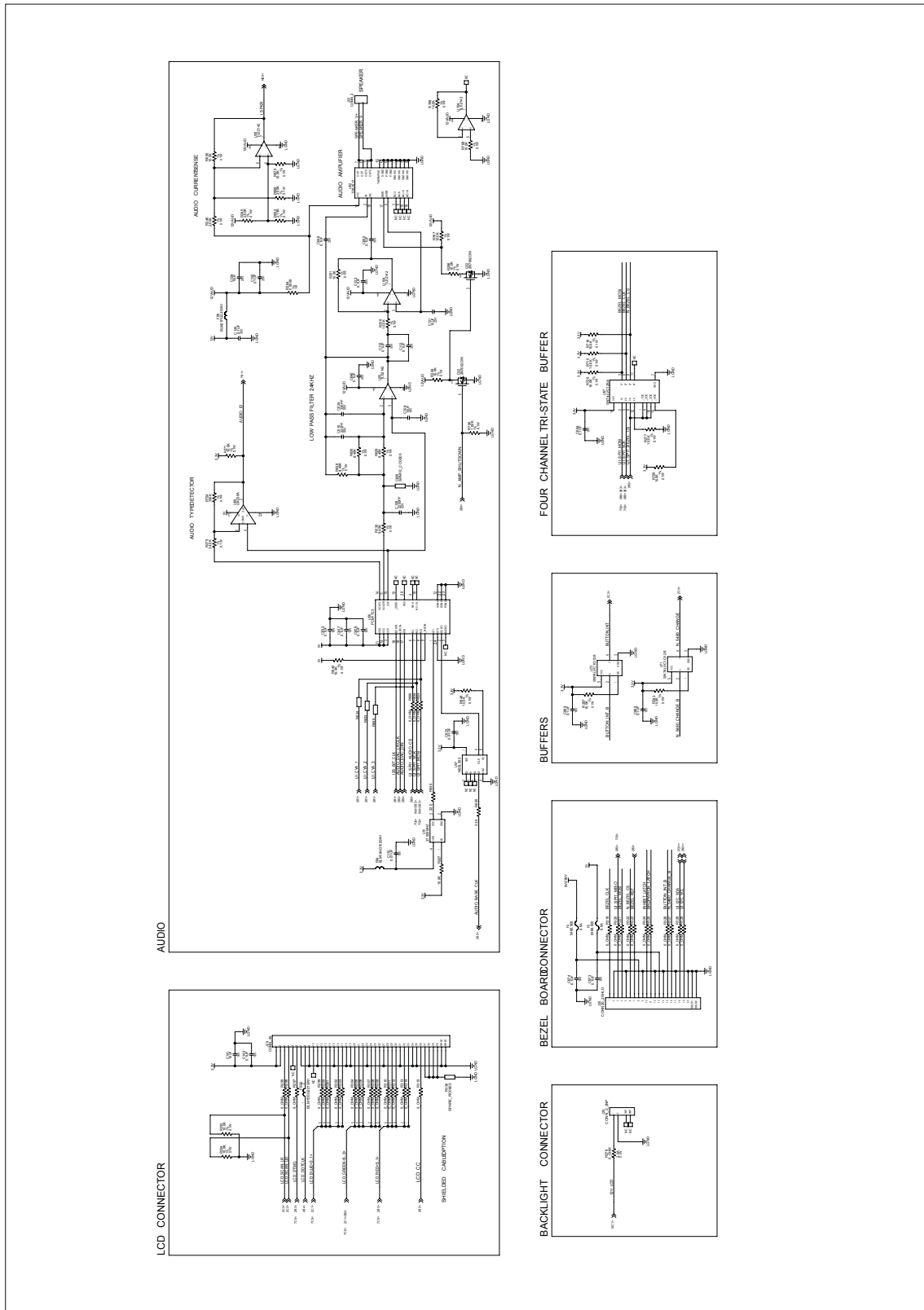

Schematic - Power Supplies

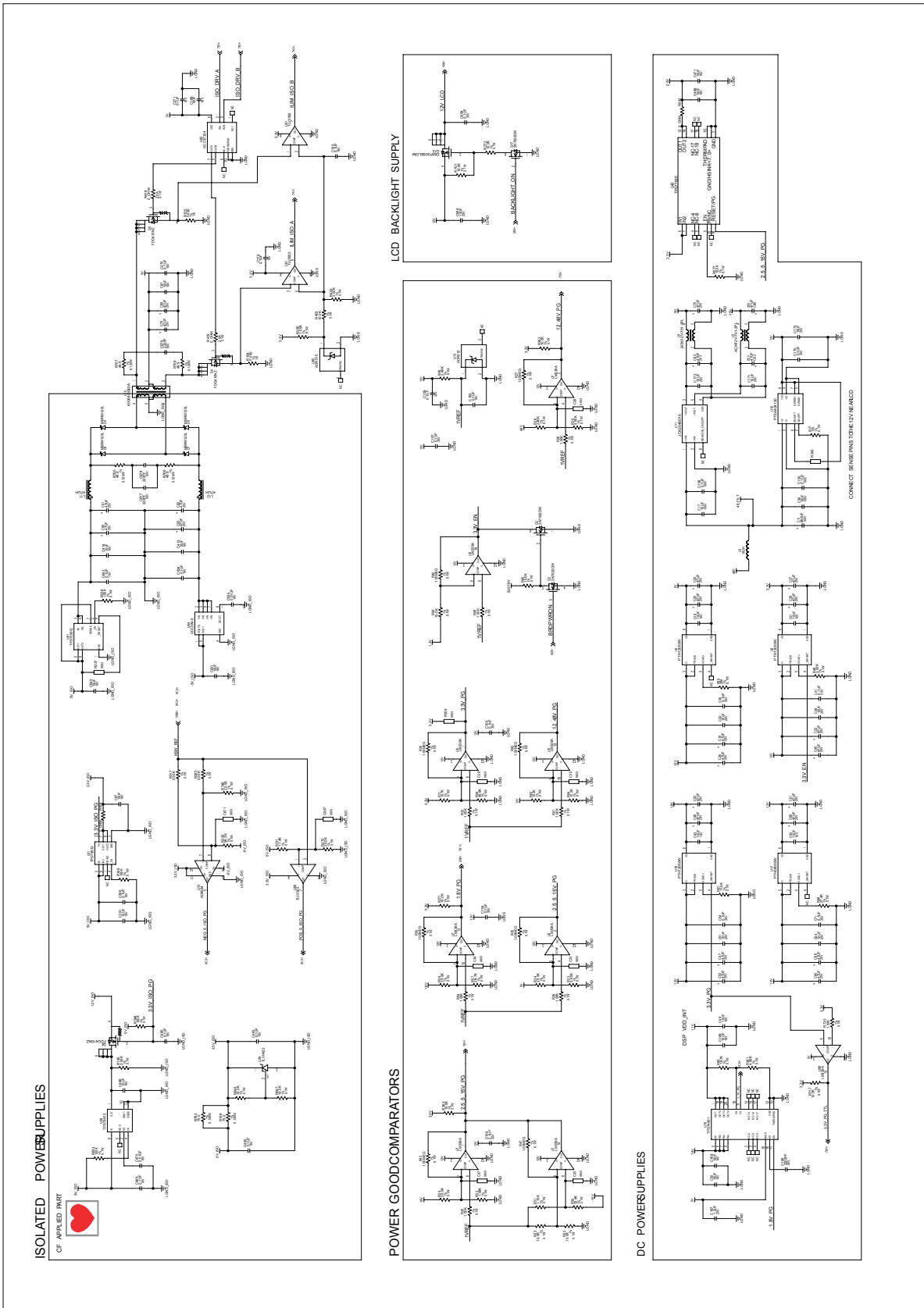

Schematic - Amplifier

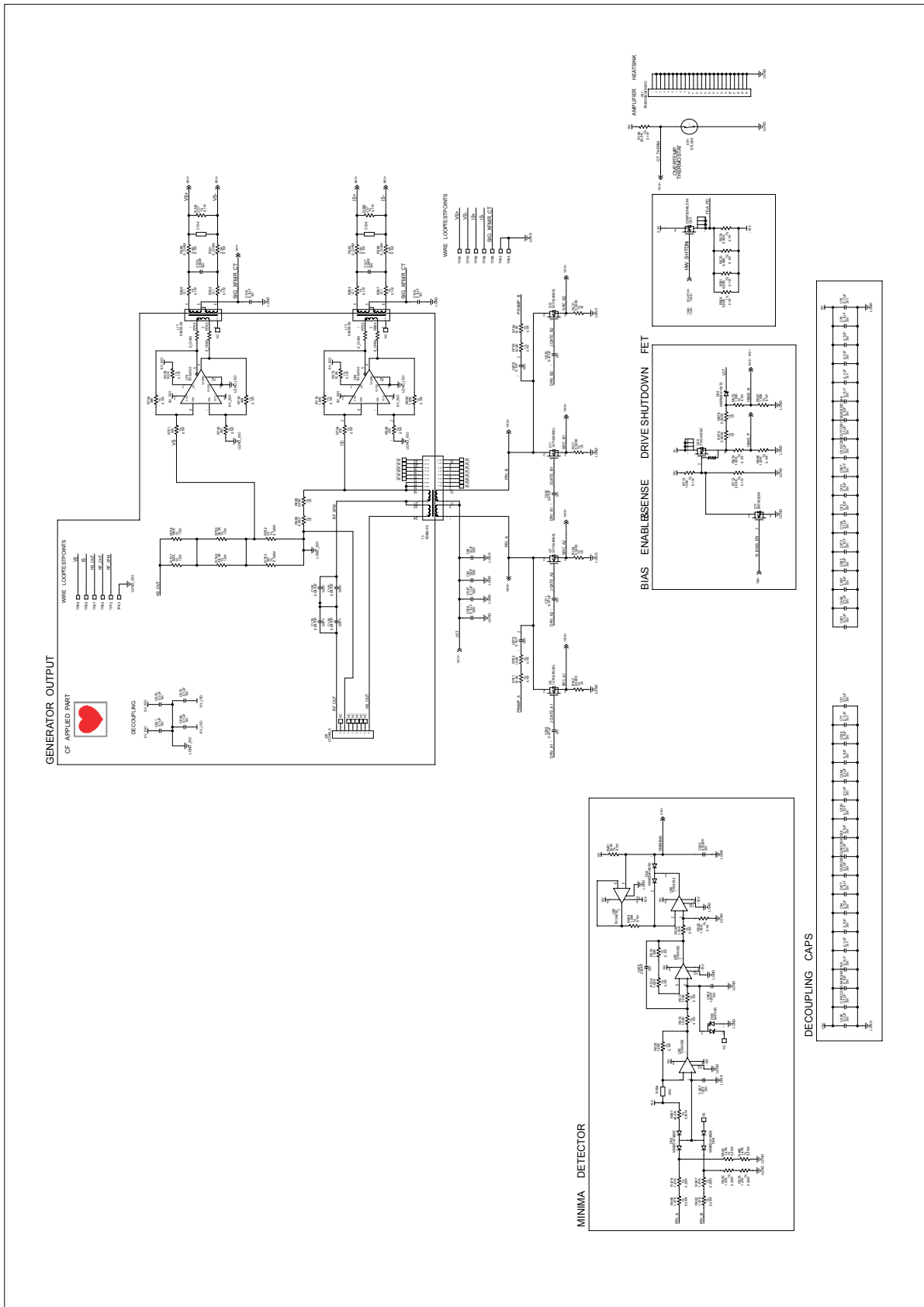

Schematic - Power Input and Buck Regulator

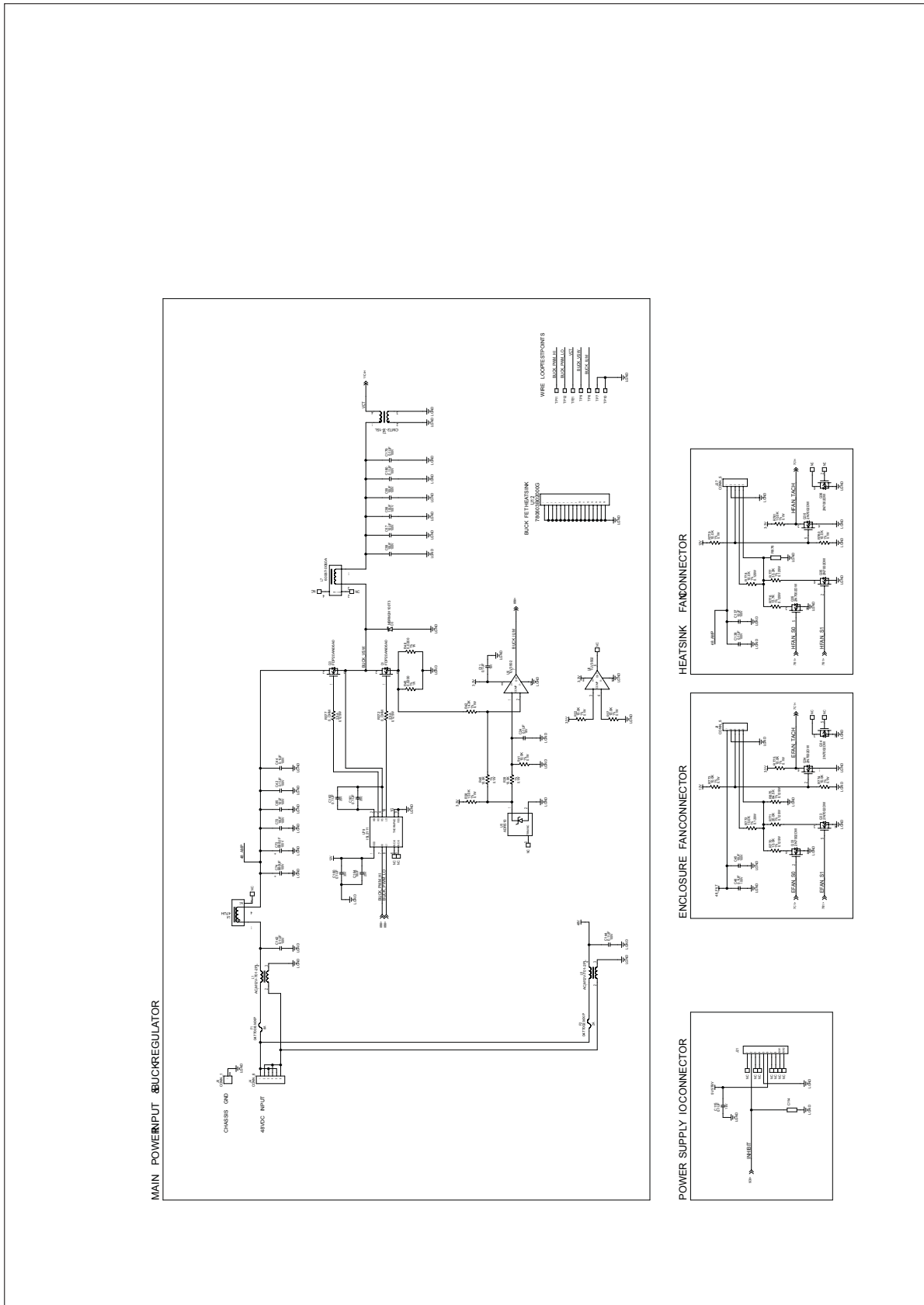

Additional Hardware Troubleshooting Information

Note: Voltages listed are +/-10% unless otherwise indicated.

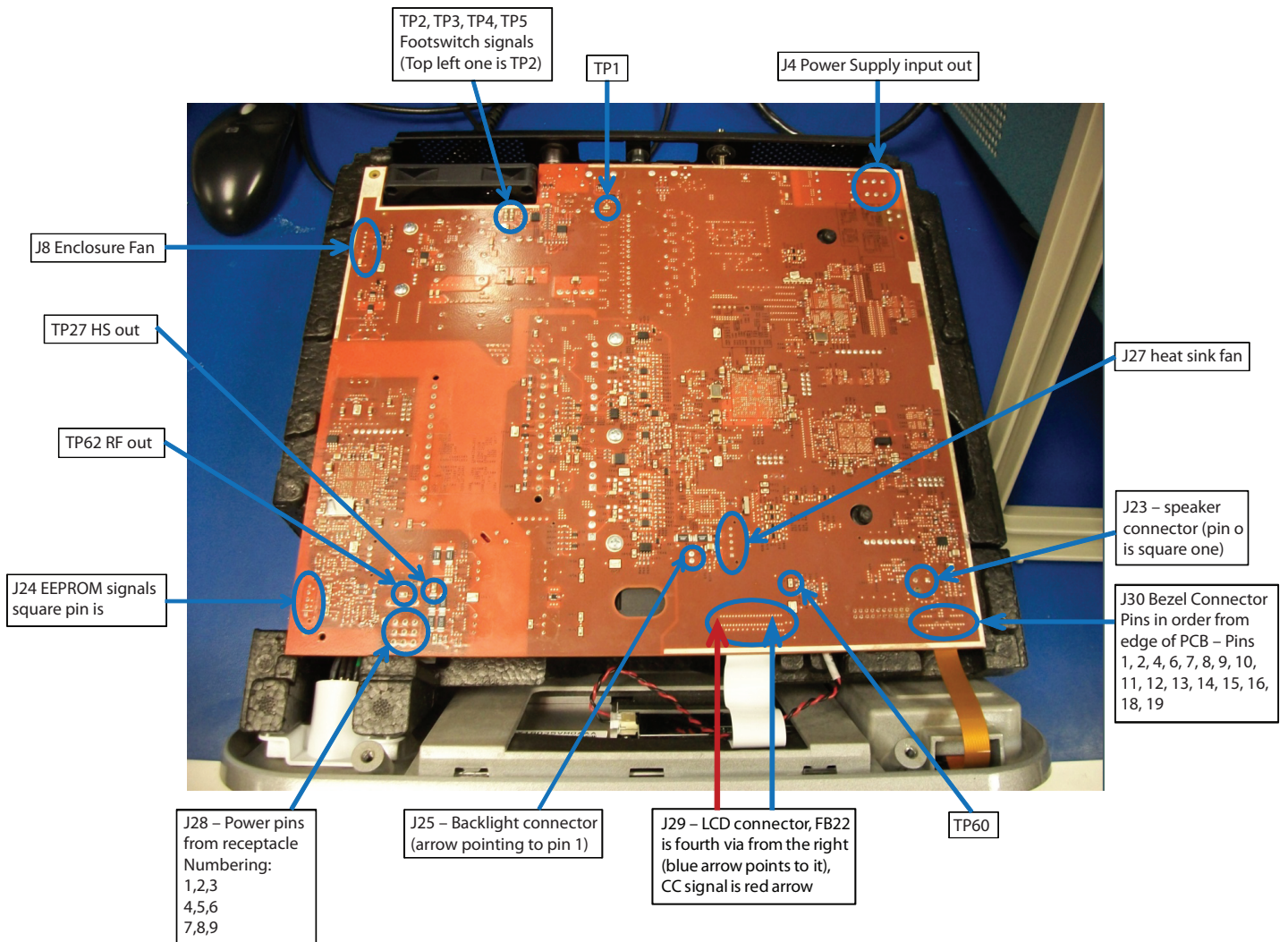

Figure 47 - Access Points Used For GEN11 Troubleshooting While Powered

- Large TP are ground.
- If all the LED are continuously lit, it indicates that the PCB has failed.

Troubleshooting Using PCB Interface Signals:

Interface from PCB to:

- i. LCD Display
 - Backlight connector (J25)
 - 12VDC at J25.1
 - LCD connector (J29)
 1. Check for good connection.
 2. Check for clock on LCD_DOTCLK (FB22 or R167) UI processor is sending a clock to LCD.

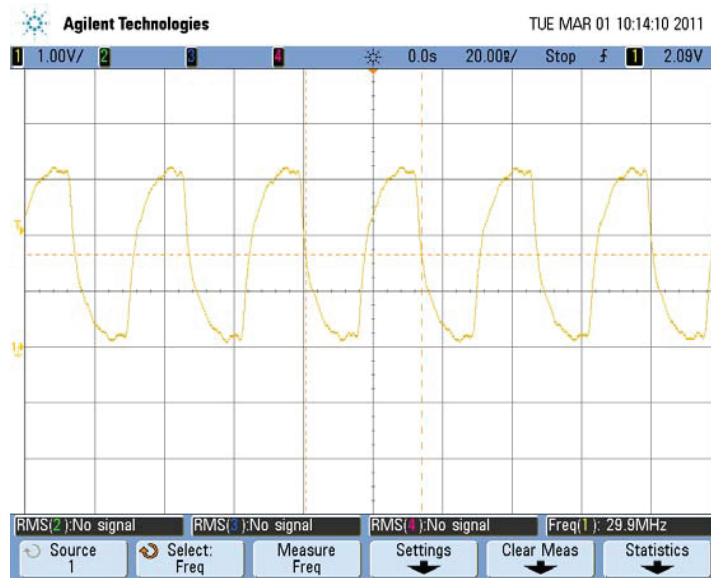

Figure 48

3. Check for data timing signal (next to dot clock signal third from the right in Figure 48). This shows the UI is properly writing and refreshing the LCD with data. If this signal does not exist, then the PCB is defective.

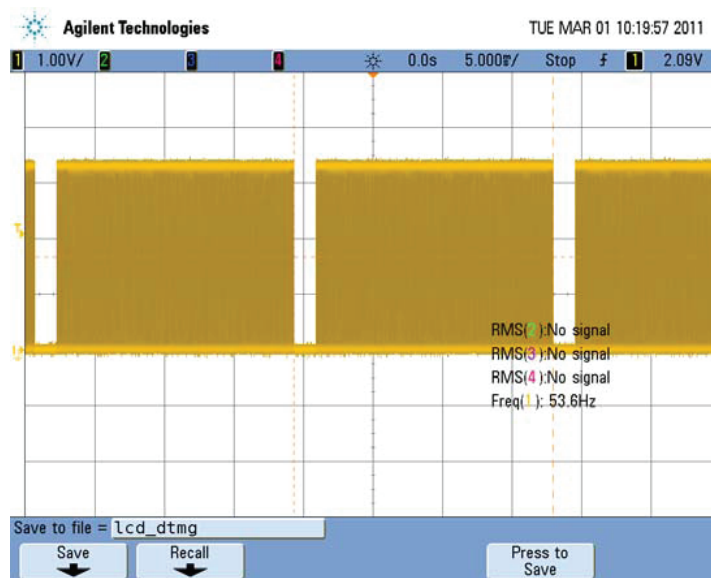

Figure 49

4. Check for LCD CC signal (very end – first on the top left in Figure 49.) If this signal does not exist, then the LCD is defective.

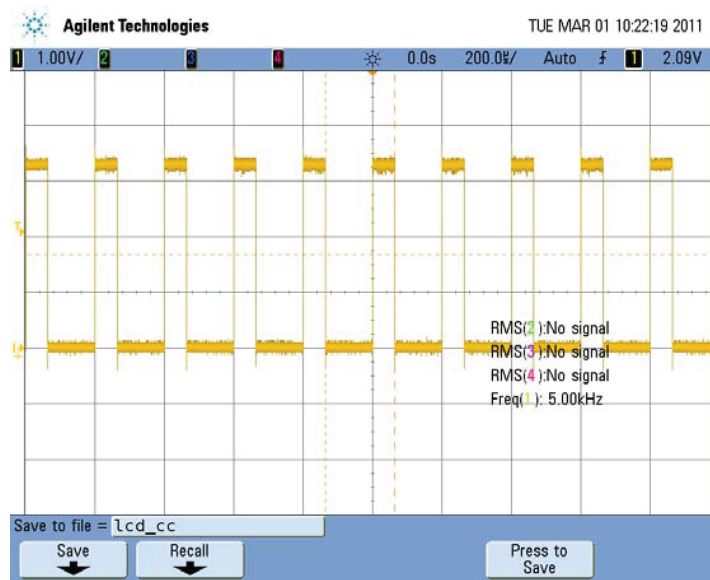

Figure 50

ii. Speaker

- Speaker connector (J23)
 1. Check V+ (J23.1) and V- (J23.2) for activity when signal is expected.
 - No signal both pins ~+5.6 VDC
 - When activating see ~2Vp/p signal riding on ~+5.6 VDC
 - If this signal does not exist, then the PCB is defective.

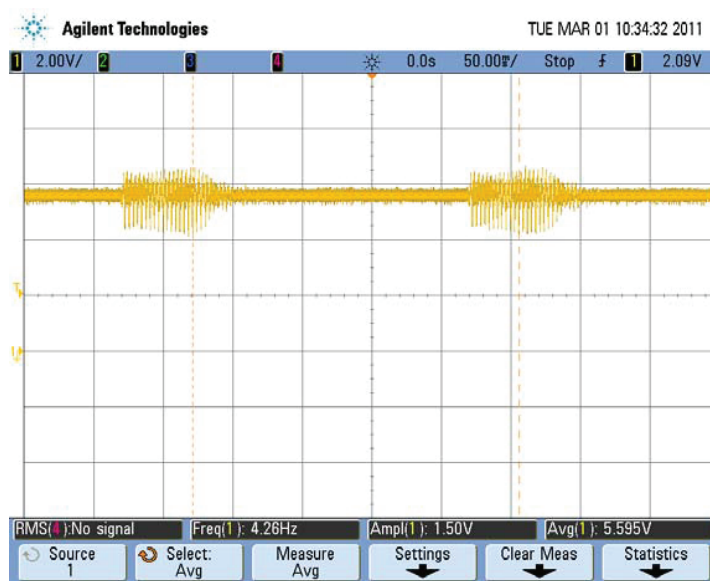

Figure 51

2. The speaker current (I_{SPKR}) feeds to a comparator and outputs AUDIO_SNS (TP60). This test point should indicate 3.3V when the speaker current passes a certain threshold. If there is activation without current, then the speaker is defective. If there is no current when audio signal in step above is present, then the speaker is defective.

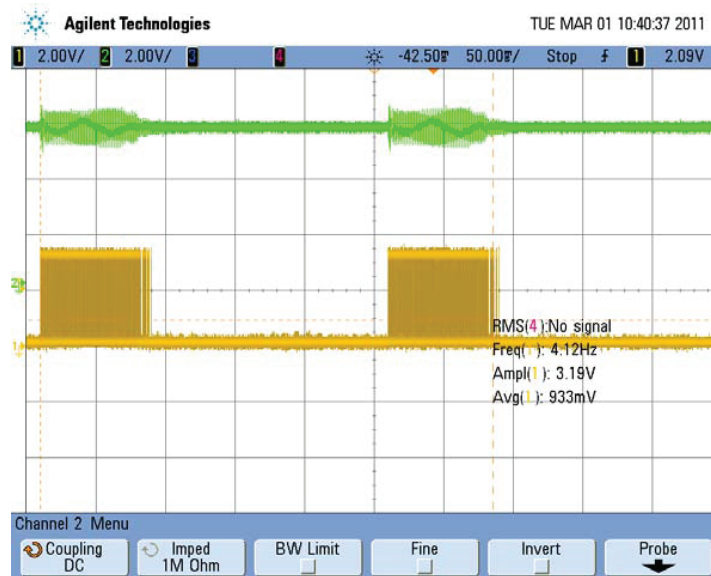

Figure 52

iii. Handpiece Receptacle

Check for continuity between handpiece inputs and its connectors.

1. J24 pins 1-5. J24
 - Pin 4 is presence (also TP 64) - Pin 4 to Pin 3 is shorted when HP is present
 - EEPROM data on Pin 1
 - Handswitch signals on Pin 5 (and also future instrument EEPROM signal)
2. J28 power drive signals to the instruments.
 - Pin 1 (TP62) is RF out (EnSeal output signals)
 - Pin 9 (TP27) is HS out (Harmonic output signals)
 - Pin 3 is ground return

iv. Footswitch Receptacle

Connects to J5.

1. FSW_MON (TP2) is expected to follow the FSW_CLK signal almost exactly. (Check if all the FETs are switching properly to keep track of the PCB circuitry.)

2. FSW_CLK (TP1) is expected to be a 2 kHz square wave (0 to 3.3V).

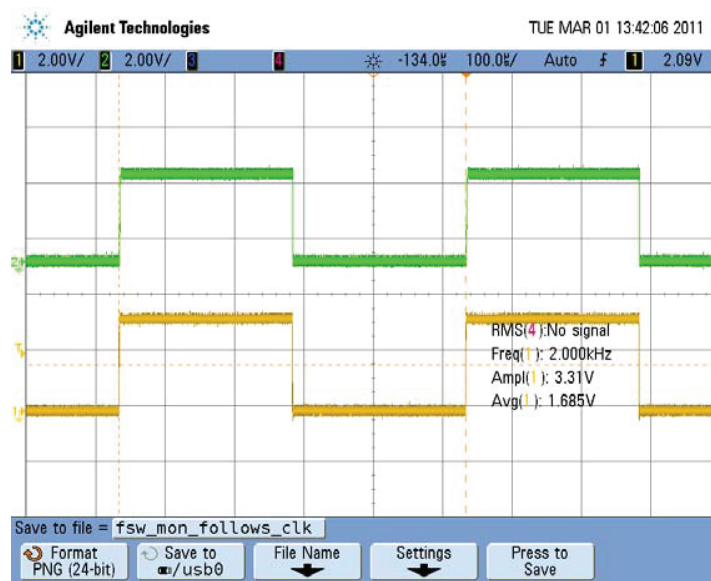

Figure 53

3. FSW_PRS (TP3) is expected to be 3.3V when footswitch is present. FSW_PRS signal dips low on every edge of the clock if footswitch is not present. Stays high if footswitch is present.

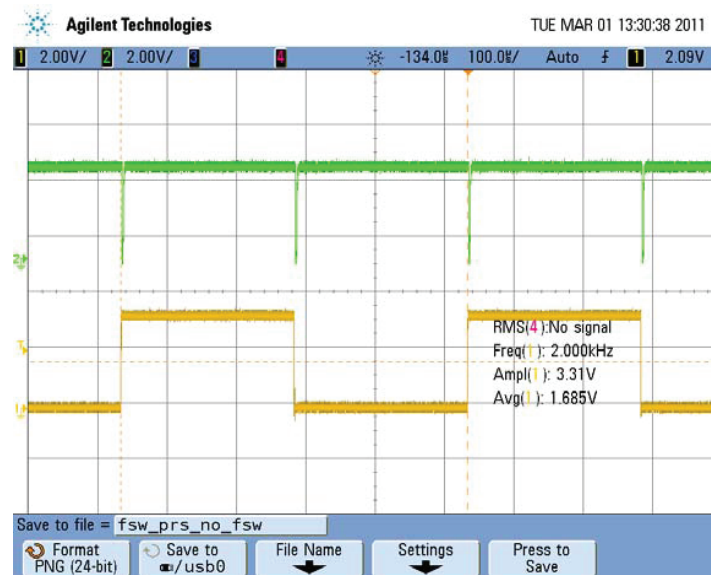

Figure 54

4. FSW_MAX (TP4) – If “MAX” is pressed, this signal is expected to be 3.3V after the rising edge of FSW_CLK. Dips low if MAX pedal is not pressed on rising edge of the clock.
5. FSW_MIN (TP8) – If “MIN” is pressed, this signal is expected to be 0V after the falling edge of FSW_CLK. Normally low, spikes high on the falling edges of the clock when the MIN pedal is not pressed, but will stay low when the pedal is pressed.

v. Power Supply

- AC power inlet and cable assembly.
- Check for 48V at J4.1 with respect to GND at J4.6 or any GND test point.

vi. Bezel PCB

- Bezel Board Connector (J30)
 1. Check UI_SPI1_MISO, (J30.2) for periodic activity – which means that PCB is trying to communicate to Bezel.

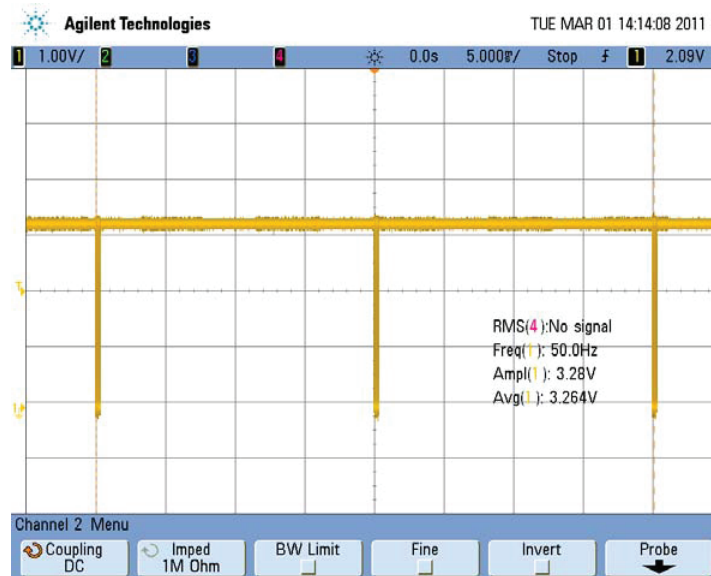

Figure 55

2. Check level of N_BEZEL_CS (J30.6). It should be high (3.3V) for normal activity. If it is not high, it indicates problems with the PCB.
3. Check level of BEZEL_RST (J30.7). It should be low under normal conditions. If it is high, it indicates problems with the PCB.
4. Check level of INHIBIT_LATCH (J30.10). It should be high (3.3V) in normal operation. If low, it indicates a problem with the Bezel PCB.
5. Check level of BRDPWRON_LATCH (J30.11 or R325). It should be high (3.3V) in normal operation. If low, it indicates problem with the Bezel PCB.
6. Remove the power supply control cable to test if the generator does not turn on. Allows generator to turn on if Bezel PCB is not operating.

vii. Fans

- Enclosure Fan Connector (J8)
 1. Check for 48V at J8.1. If the fan does not move and this voltage is present, then the fan is defective.
 2. Pin 3 is tach signal coming back from fan.
 3. Pins 4 and 5 are related to fan speed for future functionality.
- Heatsink Fan Connector (J27)
 1. Check for 48V at J27.1. If the fan does not move and this voltage is present, then the fan is defective.
 2. Pin 3 is tach signal coming back from fan.
 3. Pins 4 and 5 are related to fan speed for future functionality.

Power versus Load Curves

Power versus Load Resistance (Impedance)

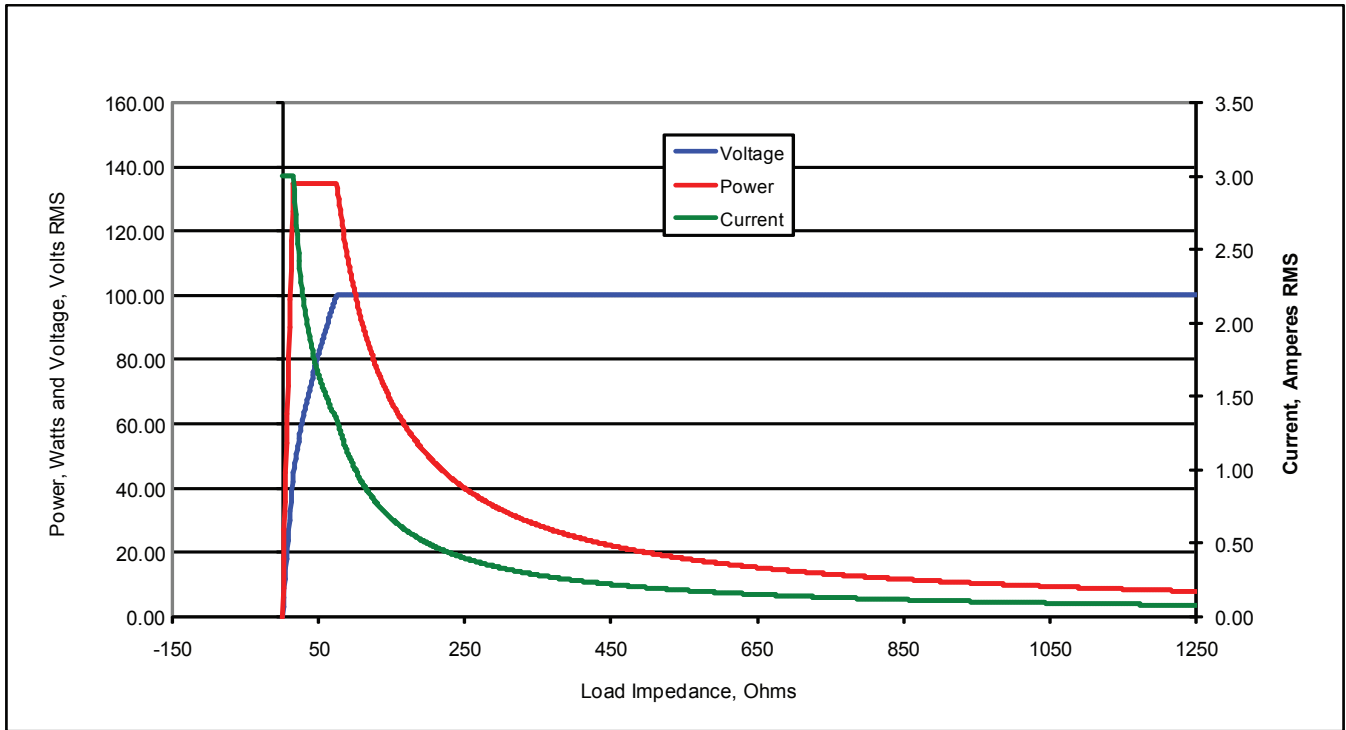

Figure 56 - Electrosurgical Power versus Load Resistance

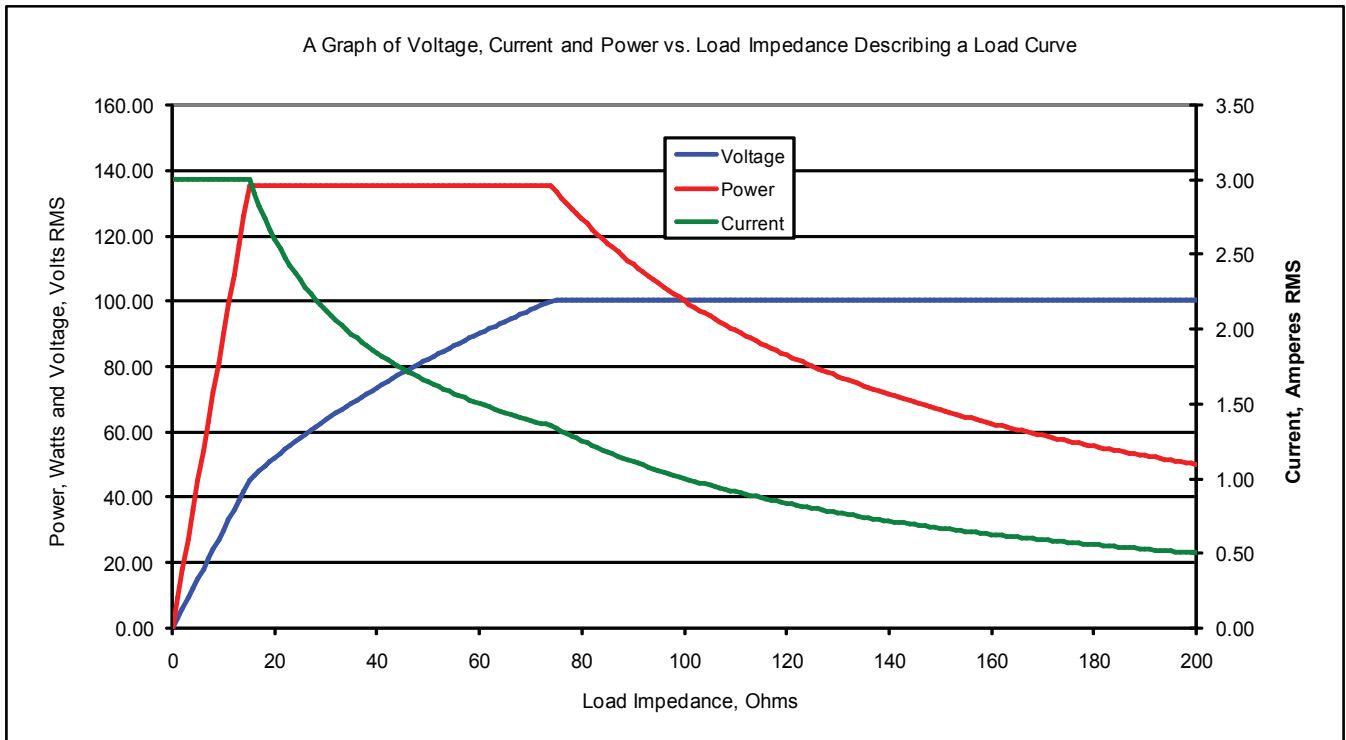

Figure 56a - Zoomed View of Electrosurgical Power Versus Load Resistance

Voltage versus Load Resistance (Impedance)

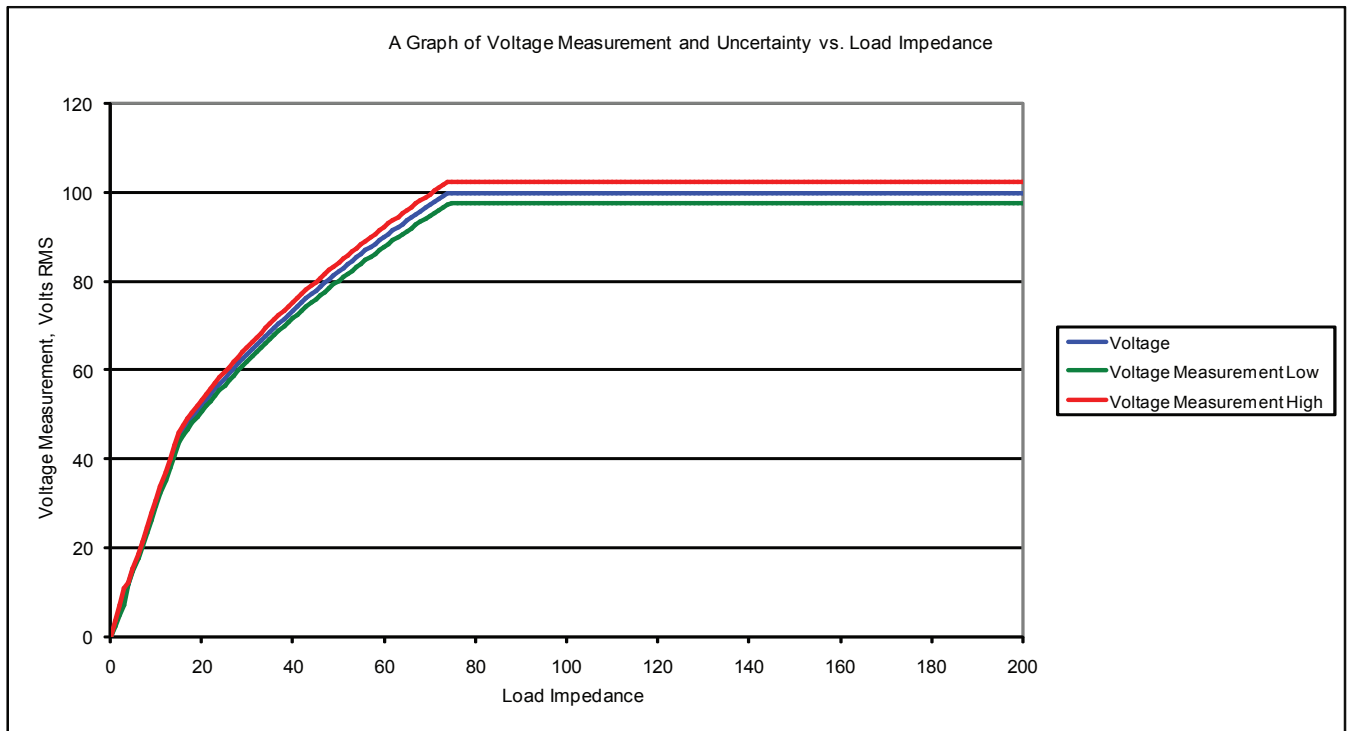

Figure 57 - Electrosurgical Voltage Measurement versus Load Impedance

Impedance Measurement versus Load Impedance

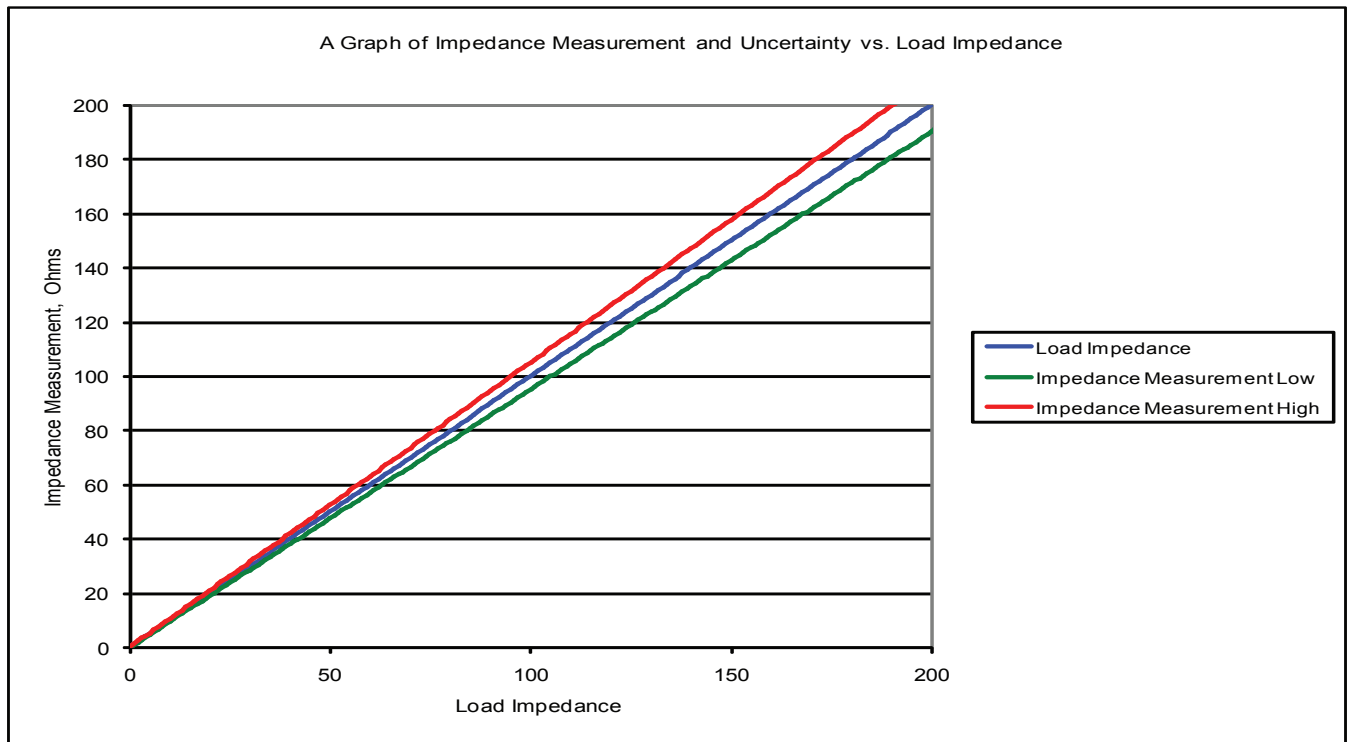

Figure 58 - Electrosurgical Impedance Measurement versus Load Impedance

Measurement Uncertainty versus Load Impedance

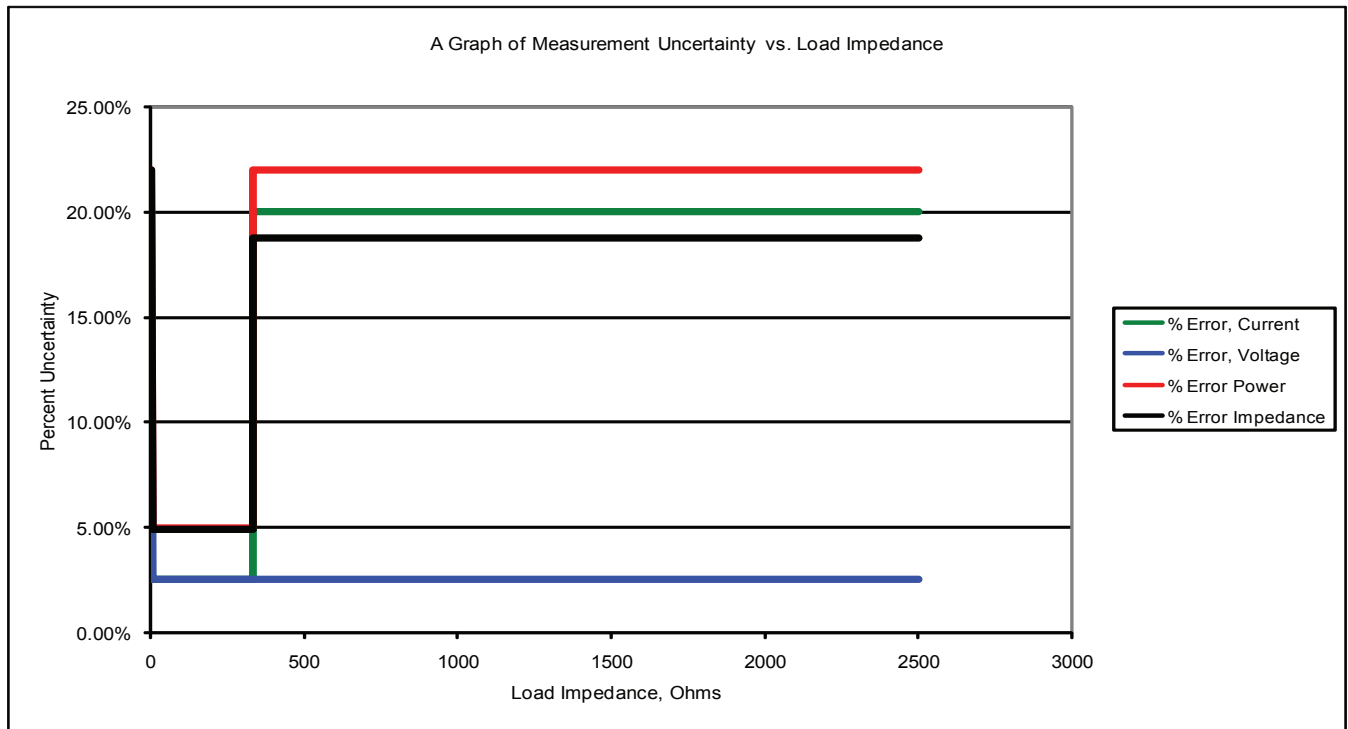

Figure 59 - Electrosurgical Measurement Uncertainty versus Load Impedance

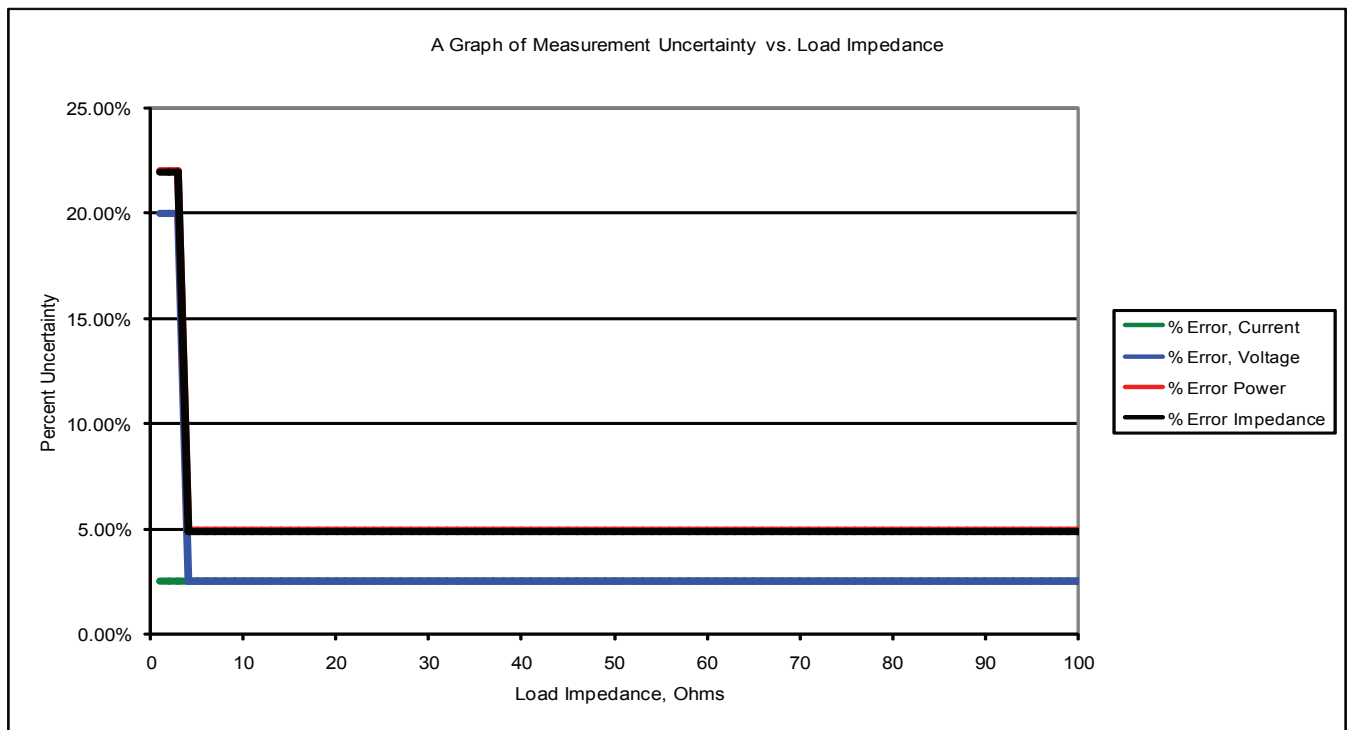

Figure 59a - Zoomed View of Electrosurgical Measurement Uncertainty versus Load Impedance

System Specifications

Main Fuses	T5AL 250 V (Time-delay, 5 Amp, glass body, 5x20 mm package size, quantity: 2)
Degree of Protection Against Electric Shock	Type CF applied part consisting of the Harmonic or EnSeal instruments
Class of Protection Against Electric Shock	Class 1
Ingress Protection G11 Enclosure	IP21
Ingress Protection G11 Footswitch	IP68
Main Input	100 - 240 V ~, 50/60 Hz, 500 VA
Output	<p>EnSeal Output: Bipolar, no neutral electrode required 100 VAC RMS maximum 135 watts maximum (rated load 15 ohms) 300 - 490 kHz (330 kHz unless otherwise marked in instrument IFU)</p> <p>Harmonic Output: 150 VAC RMS maximum 35 watts maximum 30 - 80 kHz (55.5 kHz unless otherwise marked in instrument IFU)</p>
Ambient Operating Conditions	Temperature: 59° F to 80.6° F, 15° C to 27° C Humidity: 30% - 75% non-condensing Atmospheric Pressure Range: 700 hPa - 1060 hPa
Transport and Storage Conditions	Temperature: -31° F to 129.2° F, -35° C to +54° C Humidity: 10% - 95% non-condensing Atmospheric Pressure Range: 700 hPa - 1060 hPa
Weight	Generator: 13 lbs (5.9 kg) Cart: 37 lbs (16.8 kg) Footswitch: 8 lbs (3.6 kg)
Overall Dimensions	Generator: 13.76" (35.0 cm) x 13.98" (35.5 cm) x 5.34" (13.6 cm) Cart: 18.88" (48.0 cm) x 22.11" (56.2 cm) x 37.53" (95.3 cm) Footswitch: 13.45" (34.2 cm) x 7.50" (19.0 cm) x 4.10" (10.4 cm)
Power Cord	<p>North American removable power cord set with the following characteristics: Plug Style: NEMA 5-15 (clear) North American Hospital Grade Receptacle: IEC 60320 C13 with straight non-angled cord entry Cord Length: 4.6 meters nominal Current Rating: 13A Voltage Rating: 125 VAC minimum Wiring Code: North American Cordage Description: SJT (UL) or SJT (CSA) Conductors: 16 AWG 3C Agency Approvals Required: UL and CSA</p> <p>International removable power cord set with the following characteristics: Plug Style: as needed by particular country requirements Receptacle: IEC 60320 C13 with straight non-angled cord entry Cord Length: 2.44 - 4.6 meters nominal Current Rating: 10A Minimum conductor size cross-sectional area: 1.0mm² copper Voltage Rating: 250 VAC minimum Wiring: International Cordage Type: HAR Item to have certification by at least one of the following agencies: VDE, ASTA, SEMKO, KEMA, LCIE, DFT, IMQ, SEV</p>

Electromagnetic Compatibility (EMC)

The Generator G11 requires special precautions regarding electromagnetic compatibility (EMC) and must be installed and used in accordance with the EMC information provided in this guide. The Generator G11 is intended for use in the electromagnetic environments specified below.

Caution: Ensure that the Generator G11 is used only in these environments.

Electromagnetic Emissions

Emissions Test	Compliance	Guidance
RF emissions CISPR 11	Group 1 (per IEC 60601-2-2:2009)	The Generator G11 uses RF energy only for its internal function. Therefore, its RF emissions are very low and are not likely to cause any interference in nearby electronic equipment.
RF emissions CISPR 11	Class A	The Generator G11 is suitable for use in all establishments other than domestic and those directly connected to the public low-voltage power supply network that supplies buildings used for domestic purposes.
Harmonic emissions IEC 61000-3-2	Not applicable	
Voltage fluctuations/flicker emissions IEC 61000-3-3	Not applicable	

Electromagnetic Immunity Guidance

For electromagnetic immunity, essential performance is: activation tones are coupled with energy output, energy output ceases when activation switches are opened, and there is no energy output without activation switch closure.

Immunity Test	IEC 60601 Test Level	Compliance Level	Electromagnetic Environment - Guidance
Electrostatic Discharge IEC 61000-4-2	± 6kV Contact ± 8kV Air	± 6kV Contact ± 8kV Air	Relative humidity should be at least 30%.
Electrical fast Transient/Burst IEC 61000-4-4	± 2 kV on Power Supply Lines ± 1 kV on Input/Output Lines	± 2 kV on Power Supply Lines ± 1 kV on Input/Output Lines	Mains power quality should be that of a typical commercial or hospital environment.
Surge IEC 61000-4-5	± 1kV line(s) to line(s) ± 2kV line(s) to earth	± 1kV Differential Mode ± 2kV Common Mode	Mains power quality should be that of a typical commercial or hospital environment.
Power Frequency Magnetic Fields IEC 61000-4-3	3 A/m	3 A/m	Power frequency magnetic fields should be at levels characteristic of a typical location in a typical commercial or hospital environment.

Voltage Dips, Short Interrupts, and Variations on Power Supply Lines IEC 61000-4-11	<5% U_T (95% dip in U_T for 0.5 cycles) <40% U_T (60% dip in U_T for 5 cycles) <70% U_T (30% dip in U_T for 25 cycles) <5 % U_T (>95 % dip in U_T) for 5 s	<5% U_T (95% dip in U_T for 0.5 cycles) <40% U_T (60% dip in U_T for 5 cycles) <70% U_T (30% dip in U_T for 25 cycles) <5 % U_T (>95 % dip in U_T) for 5 s	Mains power quality should be that of a typical commercial or hospital environment. If the user of the Generator G11 requires continued operation during power mains interruptions, it is recommended that the Generator G11 be powered from an uninterruptible power supply or a battery.
--	--	--	--

Conducted RF IEC 61000-4-6	3 Vrms 150 kHz to 80 MHz	3 Vrms	Portable and mobile RF communications equipment should be used no closer to any part of the Generator G11, including cables, than the recommended separation distance calculated from the equation applicable to the frequency of the transmitter.
-----------------------------------	---------------------------------	--------	--

Recommended separation distance:

$$d = 1.2\sqrt{P}$$

Radiated RF IEC 61000-4-3	3 V/m 80 MHz to 2.5 GHz	3 V/m	$d = 1.2\sqrt{P}$ 80 MHz to 800 MHz $d = 1.2\sqrt{P}$ 800 MHz to 2.5 GHz where P is the maximum output power rating of the transmitter in watts (W) according to the transmitter manufacturer and d is the recommended separation distance in meters (m).
----------------------------------	--------------------------------	-------	---

Field strengths from fixed RF transmitters, as determined by an electromagnetic site survey,^a should be less than the compliance level in each frequency range.^b

Interference may occur in the vicinity of equipment marked with the following symbol:



Note: At 80 MHz and 800 MHz, the higher frequency range applies.

Note: These guidelines may not apply in all situations. Electromagnetic propagation is affected by absorption and reflection from structures, objects and people.

^aThe ISM (industrial, scientific and medical) bands between 150 kHz and 80 MHz are 6,765 MHz to 6,795 MHz; 13,553 MHz to 13,567 MHz; 26,957 MHz to 27,283 MHz; and 40,66 MHz to 40,70 MHz.

^bThe compliance levels in the ISM frequency bands between 150 kHz and 80 MHz and in the frequency range 80 MHz to 2.5 GHz are intended to decrease the likelihood that mobile/portable communications equipment could cause interference if it is inadvertently brought into patient areas. For this reason, an additional factor of 10/3 has been incorporated into the formulae used in calculating the recommended separation distance for transmitters in these frequency ranges.

Generator G11 Service Manual

Recommended separation distances between portable and mobile RF communications equipment and the Generator G11

The Generator G11 is intended for use in an electromagnetic environment in which radiated RF disturbances are controlled. The customer or the user of the Generator G11 can help prevent electromagnetic interference by maintaining a minimum distance between the portable and mobile RF communications equipment (transmitters) and the Generator G11 as recommended below, according to the maximum output power of the communications equipment.

Rated maximum output power of transmitter (W)	Separation distance according to frequency of transmitter (m)		
	150 kHz to 80 MHz $d = 1.2\sqrt{P}$	80 MHz to 800 MHz $d = 1.2\sqrt{P}$	800 MHz to 2.5 GHz $d = 1.2\sqrt{P}$
0.01	0.12	0.12	0.23
0.1	0.38	0.38	0.73
1.0	1.20	1.20	2.30
10	3.79	3.79	7.27
100	12	12	23

For transmitters rated at a maximum output power not listed above, the recommended separation distance d in meters (m) can be estimated using the equation applicable to the frequency of the transmitter, where P is the maximum output power rating of the transmitter in watts (W) according to the transmitter manufacturer.

Note: At 80 MHz and 800 MHz, the separation distance for the higher frequency range applies.













Note: These guidelines may not apply in all situations. Electromagnetic propagation is affected by absorption and reflection from structures, objects and people.











Conformance to Standards

The Generator G11 conforms to the following international standards:

EN (IEC) 60601-1 (with Canadian and US National Deviations)	Medical electrical equipment - Part 1: General requirements for basic safety and essential performance
EN (IEC) 60601-1-2	Medical electrical equipment - Part 1-2: General requirements for basic safety and essential performance - Collateral standard: Electromagnetic compatibility - Requirements and tests
EN (IEC) 60601-2-2	Medical electrical equipment - Part 2-2: Particular requirements for the safety of high frequency surgical equipment
EN (IEC) 60601-1-8	Medical electrical equipment - Part 1-8: General requirements for basic safety and essential performance - Collateral standard: General requirements, tests and guidance for alarm systems in medical electrical equipment and medical electrical systems

Symbols

	Footswitch
	Non-ionizing Radiation
	Equipotential Ground Lug
	Electrical and Electronic equipment. Return waste to a collection system or treatment and recycling facilities. Applicable in the EU. Follow decontamination instructions before returning waste.
	Authorized Representative in the European Community
	Manufacturer
	On/Off Switch
	Caution: Federal (USA) law restricts this device to sale by or on the order of a physician.
	Keep Dry
	Date of Manufacture
	Reorder Number
	Serial Number
	Authorized Representative in the USA

	<p>Refer to instructions manual / booklet.</p>
<p>NON-STERILE</p>	<p>Non-sterile</p>
	<p>CF Applied Part (Device Connector)</p>
	<p>The electronic information product (EIP) has met the requirements set forth by the People's Republic of China for marking of EIPs, and can be used during its environmental protection use period of 50 years. After the environmental protection period has expired, the EIP should be recycled. Applicable in the People's Republic of China.</p>
	<p>Fuse</p>
	<p>Product is certified by a Nationally Recognized Testing Laboratory.</p>
	<p>Consult the Generator G11 Operator's Manual.</p>
	<p>Recyclable Packaging</p>
	<p>Relative Humidity</p>
	<p>Temperature</p>
	<p>Low Alarm</p>
	<p>Medium Alarm</p>



REF
GEN11, CRT11

EC REP Ethicon Endo-Surgery (Europe) GmbH
Hummelsbuetteler Steindamm 71
22851 Norderstedt
GERMANY

USA REP Ethicon Endo-Surgery, Inc.
4545 Creek Road, Cincinnati, OH 45242-2839 USA
1-800-USE-ENDO



ETHICON ENDO-SURGERY, LLC © EES, LLC 2011
Guaynabo, Puerto Rico 00969 USA

Rev. 2011-04

P43566P02