EQUIPMENT SUBMITTAL FOR APPROVAL

PROJECT: October 2024 Bulk Order Applied Chillers

LOCATION:



Air-Cooled Chiller

EQUIPMENT	YVAA Chiller
UNIT TAGS	CH-1
QUANTITY	1

SOLD TO:

CONSULTING ENGINEER:

PREPARED BY:

DATE:

Wednesday, 06 November 2024

REVISION:

0



TABLE OF CONTENTS

(YVAA - Air-Cooled Chiller)

BOM Data

Performance Ratings

Unit Drawings

Wiring Diagrams

Unit Specifications Text

Warranties

Submittal Approval Page



BID DATE: 11/06/2024
PROJECT: October 2024 Bulk Order Applied Chillers
TO: Interested Bidders

LAST ADDEDNUM: None
NOTE(S)

BILL OF MATERIAL

<u>ITEM</u>	<u>QTY</u>	<u>TAGS</u>	<u>DESCRIPTION</u>
I	1	(1)CH-1	DIRECT EXPANSION - AIR COOLED SCREW CHILLER

EQUIPMENT DESCRIPTIONS

EQUIPMENT PROPOSAL

Items Included

- Provide Model YVAA0500JC46CH Qty: 1
- Refrigerant Type: R-513A
- Power: 460/3/60.0 Application
- Power Connection: MP Circuit Breaker w/ Lockable Handle
- Starter Type: Standard VSD
- TEAO Fan Motors
- Low Sound Fans With Variable Speed Control
- 3/4 Inch Single Thickness Insulation of Evaporator
- Microchannel Coils
- Suction And Filter Dryer Service Valve
- Entire Unit Parts Only Warranty: 18 Month (1 Year) (Std) (Months are from date of shipment/Years are from date of start up, whichever expires first)
- Entire Unit Labor Only Warranty: 18 Month (1 Year) (Std) (Months are from date of shipment/Years are from date of start up, whichever expires first)
- Control Transformer
- Standard Factory Sound Kit (Level 0 Reduction)
- Discharge Pressure Readout Kit ASME Pressure Vessel Codes
- Flow Switches One Thermal Dispersion Switch
- Low Ambient Kit Standard Factory Sound Kit (Level 0 Reduction)
- Suction And Filter Dryer Service Valve
- V-Guard Panels plus Hail Guards (factory)

Items Included but Installed by Others

Items NOT Included

- Hauling or Rigging Equipment Into Place.

Project Name: **October 2024 Bulk Order Applied Chillers**

Unit Tag: **CH-1**

Qty.: **1**

Model: **YVAA0500**

Full Load - Design

PIN

YVAA0500JC	V46CHVMXXX	SAXLXXXX60	44XOFXXG19	9W1SXGA2BM	XVDXNXXXXXX	XBXSXX		
...5...10	...5...20	...5...30	...5...40	...5...50	...5...60	...5...70	...5...80	...5...90

Unit	
Model No.	YVAA0500
Number of Compressors	2
Compressor Type	VSD Screw - Semi Hermetic
Number of Compressor Circuits	2
Capacity Control	10% - 100%
Refrigerant	R-513A
Performance Data	
Net Cooling Capacity [tons.R]	480.0
Total Power Input [kW]	713.3
EER [Btu/W.h]	8.076
IPLV.IP [Btu/W.h]	17.30
A-Weighted Sound Power [dB(A)]	112.0
Electrical Data	
Nominal Voltage / Voltage Limits	460/3/60.0 / 414V - 508V
Compressor kW (each circuit)	341.1 / 339.6
Compressor RLA (each circuit) [A]	451.2 / 449.2
Fan QTY (each circuit)	10 / 10
Fan FLA (each circuit) [A]	2.4 / 2.4
Min. Circuit Ampacity (each system) [A]	593.7 / 585.5
Max. Fuse / CB Rating (each system) [A]	1000.0 / 1000.0
Unit Short Circuit Withstand [kA]	65 kA
Wires Per Phase (each system)	2 / 2
Wire Range (Lug Size) (each system)	#1 - 500 kcmil / #1 -500 kcmil
Displacement Power Factor	0.95
Control kVA	3.000



Performance Impacting Options

End User Application	Comfort Cooling
Compressor Style	High Capacity Standard Part Load Efficiency (GTS)
Condenser Coil	Microchannel Coils
Fan	Low Sound Fans With Variable Speed Control
Sound Attenuation	Standard Factory Sound Kit (Level 0 Reduction)

Weight & Dimensional Data

Shipping Weight [lbs]	24587
Operating Weight [lbs]	25672
Refrigerant Charge [lbs]	366 / 390
Length [in]	467.1
Width [in]	88.3
Height [in]	94.6

Project Name: **October 2024 Bulk Order Applied Chillers**

Unit Tag: **CH-1**

Qty.: **1**

Model: **YVAA0500**

Heat Exchanger Performance			
Evaporator		Condenser (Air Cooled)	
Heat Exchanger Type	Hybrid Falling Film	Ambient Air Temperature* [°F]	95.0
Entering Fluid Temperature* [°F]	54.00	Altitude* [ft]	0.00
Leaving Fluid Temperature* [°F]	44.00	Condensing Temperature [°F]	141.73 / 141.44
Flow Rate [USGPM]	1149	Number of Fans (Circuit 1 / Circuit 2)	10 / 10
Fouling Factor* [h ft ² F/Btu]	0.000100	Total Air Flow [cfm]	250000
Fluid Type*	Water	Total Fan Power [kW]	32.57
Passes*	2		
Pressure Drop [ft H ₂ O]	18.9		
Fluid Volume [USGAL]	146.9		
Evaporating Temperature [°F]	40.77		
Minimum Flow Rate [USGPM]	550.0		
Maximum Flow Rate [USGPM]	2160		

* Designates user specified input

Certified in accordance with the AHRI Air-Cooled Water-Chilling Packages Using Vapor Compression Cycle Certification Program, which is based on AHRI Standard 550/590 (I-P) and AHRI Standard 551/591 (SI). Certified units may be found in the AHRI Directory at www.ahridirectory.org. Auxiliary components included in total kW - Oil heaters, Chiller controls. Auxiliary power is already included in the compressor and fan power



Part Load Performance (Based on Standard AHRI Unloading)				
Percent Load	Ambient [°F]	Capacity [tons.R]	Power Input [kW]	Unit Efficiency [Btu/W.h]
100.0	95.0	480.0	713.3	8.076
75.0	80.0	360.0	322.6	13.39
50.0	65.0	240.0	145.6	19.78
25.0	55.0	120.0	64.00	22.50

Project Name: **October 2024 Bulk Order Applied Chillers**

Unit Tag: **CH-1**

Qty.: **1**

Model: **YVAA0500**

Sound Power Levels (In Accordance with AHRI 370)

Percent Load	Ambient [°F]	Octave Band Center Frequency [Hz]								LWA
		63	125	250	500	1000	2000	4000	8000	
100.0	95.0	99.0	101.0	101.0	104.0	110.0	104.0	100.0	90.0	112.0
75.0	80.0	99.0	100.0	108.0	105.0	104.0	98.0	93.0	85.0	108.0
50.0	65.0	95.0	97.0	96.0	102.0	95.0	89.0	84.0	78.0	101.0
25.0	55.0	91.0	95.0	95.0	100.0	94.0	85.0	80.0	74.0	99.0

Note: Unit is equipped with Low Sound Fans With Variable Speed Control.

Measurement of sound pressure used to obtain the sound power data presented is based on AHRI-370.

Air-cooled chillers are rated in terms of sound power not sound pressure. Johnson Controls provides estimates of sound pressure, but this is not the rating metric.

For an air-cooled chiller, sound pressure calculated from sound power varies depending on how the chiller is assumed to behave, i.e. the radiation model. In other words, determining sound pressure from sound power requires making assumptions that result in different answers at a given distance from the chiller. The environment also influences sound pressure in the field installation. Sound pressure estimation radiation models pertaining to air-cooled chillers include the 'traditional' hemispherical model, parallelepiped model and equivalent hemispherical model.

Regarding sound power, Johnson Controls references tolerance limits based on ASHRAE guidelines. These are +/- 6dB in the 63Hz octave band, +/- 4dB in all other octave bands and +/- 3dB for the overall dBA.

Tolerance limits are based on uncertainties associated with:

1. Measurement Test Procedure
2. Repeatability
3. Production / Manufacturing Variability

Standard deviation associated with air-cooled chiller sound data is a measure of spread i.e. it indicates the range of probability of sound levels. Note that for operating conditions other than AHRI's Standard Rating Condition, higher levels of uncertainty can be expected.

Lead times for factory performance testing depend on test laboratory availability. Please confirm with Johnson Controls Customer Service.

Performance at AHRI Conditions

Evaporator		Condenser	
EFT [°F]	54.00	Ambient Temp. [°F]	95.0
LFT [°F]	44.00	Altitude [ft]	0.00
Flow Rate [USGPM]	1149	Performance	
Pressure Drop [ft H2O]	18.9	EER [Btu/W.h]	8.076
Fluid Type	Water	IPLV.IP [Btu/W.h]	17.30
Fouling Factor [h ft2 F/Btu]	0.000100	Net Cooling Capacity [tons.R]	480.0
Fluid Volume [USGAL]	146.9		

Note: Unit rated at design condition capacity.

Part Load Performance (Based on AHRI 550/590 - 2023 (IP))

Percent Load	Ambient [°F]	Capacity [tons.R]	Power Input [kW]	Unit Efficiency [Btu/W.h]
100.0	95.0	480.0	713.3	8.076
75.0	80.0	360.0	322.6	13.39
50.0	65.0	240.0	145.6	19.78
25.0	55.0	120.0	64.00	22.50

Project Name: **October 2024 Bulk Order Applied Chillers**

Unit Tag: **CH-1**

Qty.: **1**

Model: **YVAA0500**

Notes:

Country of Origin: Mexico

Min DSD (Factory Purpose/Use Only):80.0 psig

Displacement Power Factor refers to compressor only. Unit Power Factor depends on fan option selected. Calculated value is available by request.

Use Copper Conductors only

The unit does not have a coil coating selected.

Minimum and maximum evaporator flow information are for full load ratings with Water.

Evaporator Passes:2, Condenser Type: M, Fan Type: V

Compliant with ASHRAE 90.1 - NC.

Compliant with IECC - 2012,2015,2018.

Field Provided Wiring for Water Box Heaters (one connection per chiller):120-1-60, 6A.

The product image shown is for illustrative purposes only and is not representative of selected options.

NOTES:

1. PLACEMENT ON A LEVEL SURFACE FREE OF OBSTRUCTIONS (INCLUDING SNOW, FOR WINTER OPERATION) OR AIR RECIRCULATION ENSURES RATED PERFORMANCE, RELIABLE OPERATION AND EASE OF MAINTENANCE. SITE RESTRICTIONS MAY COMPROMISE MINIMUM CLEARANCES INDICATED BELOW, RESULTING IN UNPREDICTABLE AIR FLOW PATTERNS AND POSSIBLE DIMINISHED PERFORMANCE. YORK'S UNIT CONTROLS WILL OPTIMIZE OPERATION WITHOUT NUISANCE HIGH PRESSURE SAFETY CUTOFF; HOWEVER, THE SYSTEM DESIGNER MUST CONSIDER POTENTIAL PERFORMANCE DEGRADATION. ACCESS TO THE UNIT CONTROL CENTER ASSUMES THE UNIT IS NO HIGHER THAN ON SPRING ISOLATORS. RECOMMENDED MINIMUM CLEARANCES: SIDE TO WALL - 6'; REAR TO WALL - 6'; CONTROL PANEL TO WALL - 4'; TOP - NO OBSTRUCTIONS ALLOWED; DISTANCE BETWEEN ADJACENT UNITS - 10'; NO MORE THAN ONE ADJACENT WALL MAY BE HIGHER THAN THE UNIT. WEIGHT AND CENTER OF GRAVITY - REFER TO AVM REPORT.
2. WATER CONNECTIONS ARE GROOVED FOR VICTAULIC CONNECTION.
3. DIMENSIONS IN mm [INCHES].

NOZZLE LEGEND

EVAPORATOR INLET LEFT END 2 PASS 8 DIA. (150psig DWP)
 EVAPORATOR OUTLET LEFT END 2 PASS 8 DIA. (150psig DWP)
 Victaulic Grooved Nozzles (per ANSI / AWWA C-606)

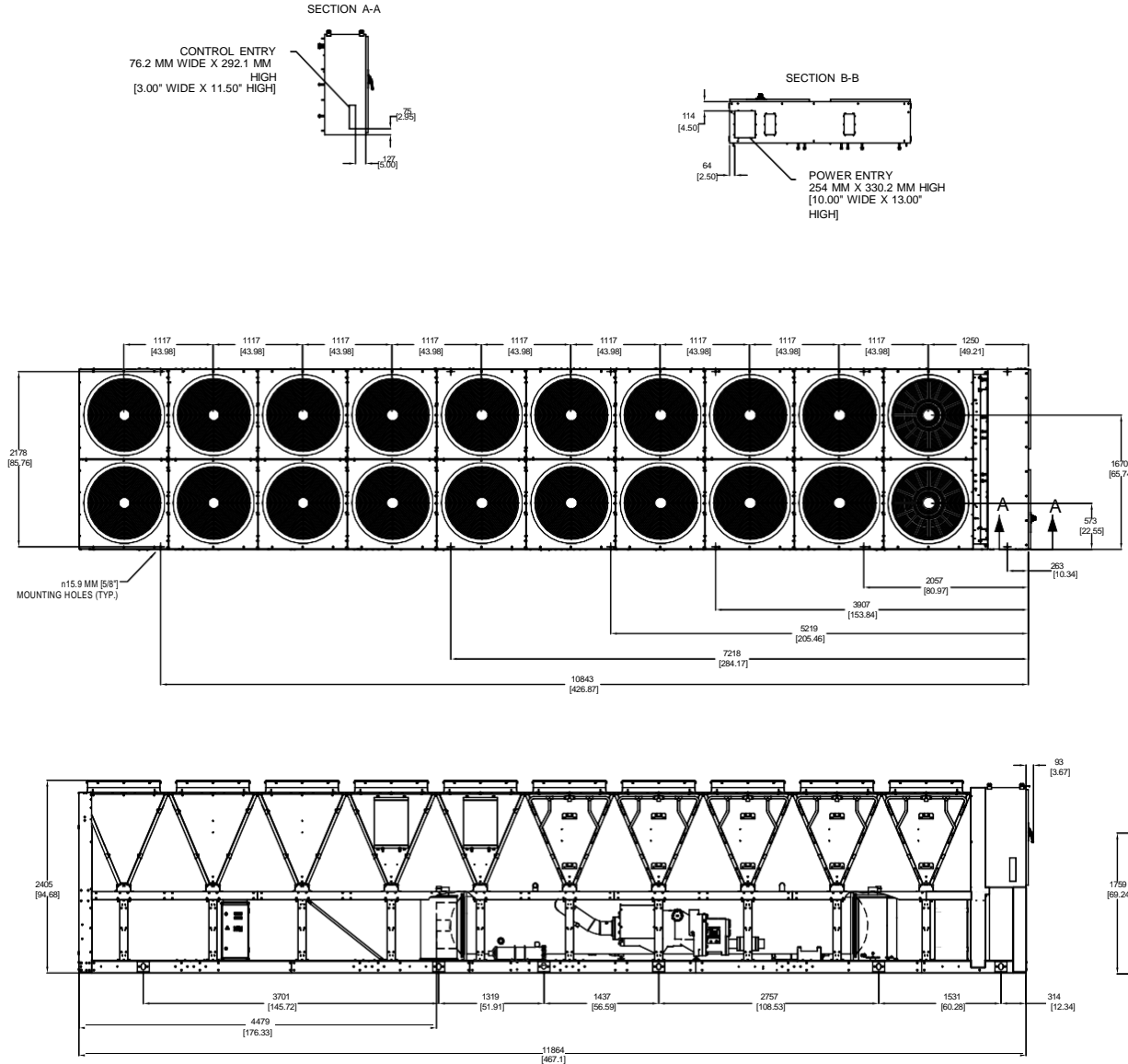

PRODUCT DRAWING

YORK YVAA Air Cooled Screw Chiller
 MODEL: YVAA 0500
 NOT FOR CONSTRUCTION

Project Name: October 2024 Bulk Order Appl
 Location: San Antonio
 Engineer:
 Contractor:
 For:

ieSddCohTiders
 Cust Purch Order#: 6
 Contract#:

Unit TAG: **CH-1**

Date: May 26, 2020
 Rev. Date: November 06, 2024
 Form No.: 201.28-EG1
 Dwg. Lev.: 0817
 Dwg. Scale: NTS



Power wiring (cont'd)



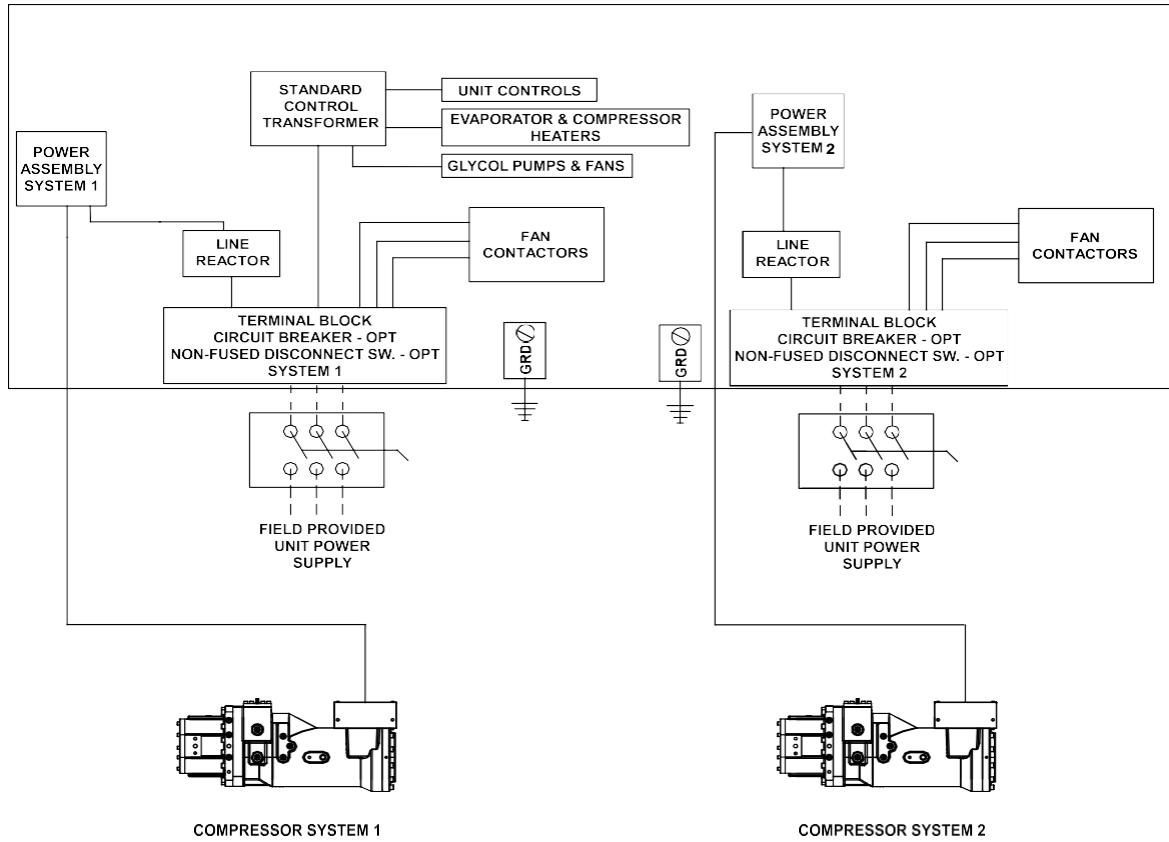

DUAL POINT WIRING

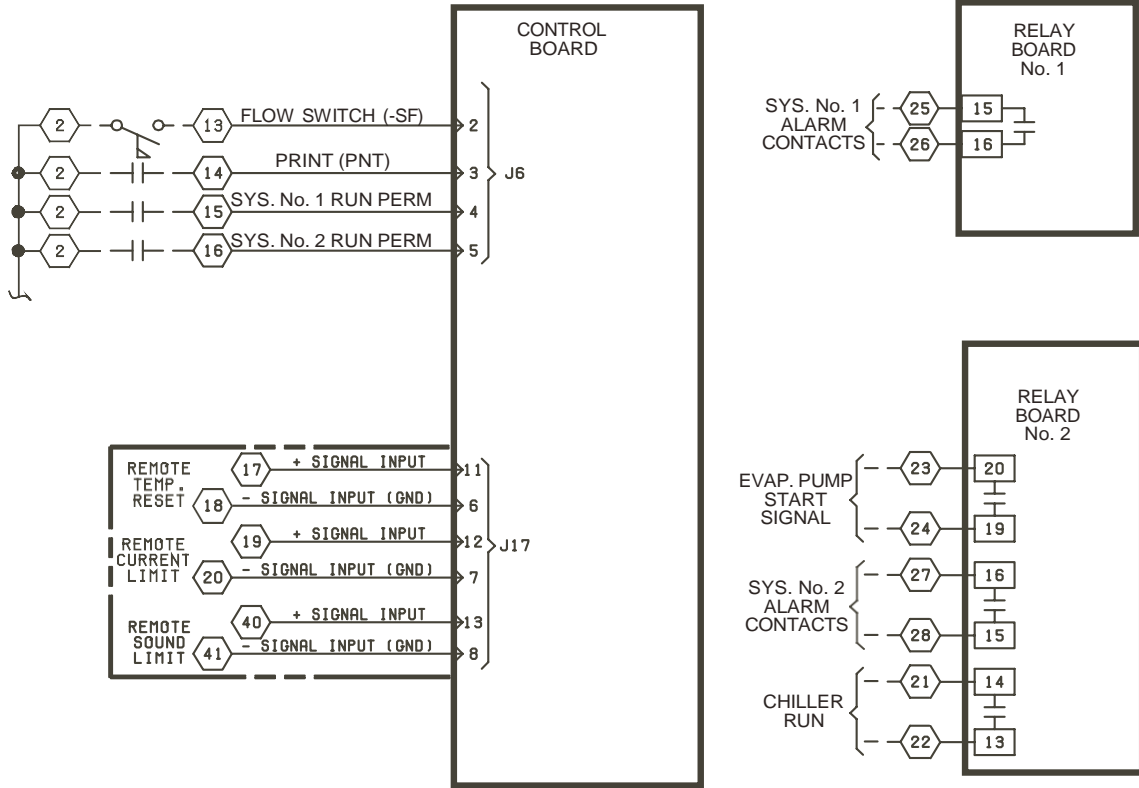

LD18589

Customer control wiring



- LEGEND**
-  TERMINAL BLOCK FOR CUSTOMER CONNECTIONS
 -  TERMINAL BLOCK FOR YORK CONNECTIONS
 -  WIRING AND COMPONENTS BY YORK
 -  OPTIONAL EQUIPMENT
 -  WIRING AND/OR COMPONENTS BY OTHERS

LD18590

AVM Report

 Project Name: **October 2024 Bulk Order Applied Chillers**

 Unit Tag: **CH-1**

 Qty.: **1**

 Model: **YVAA0500**

PIN								
YVAA0500JC	V46CHVMXXX	SAXLXXXX60	44XOFXXG19	9W1SXGA2BM	XVDXNXXXXX	XBXSXX		
...5...10	...5...20	...5...30	...5...40	...5...50	...5...60	...5...70	...5...80	...5...90

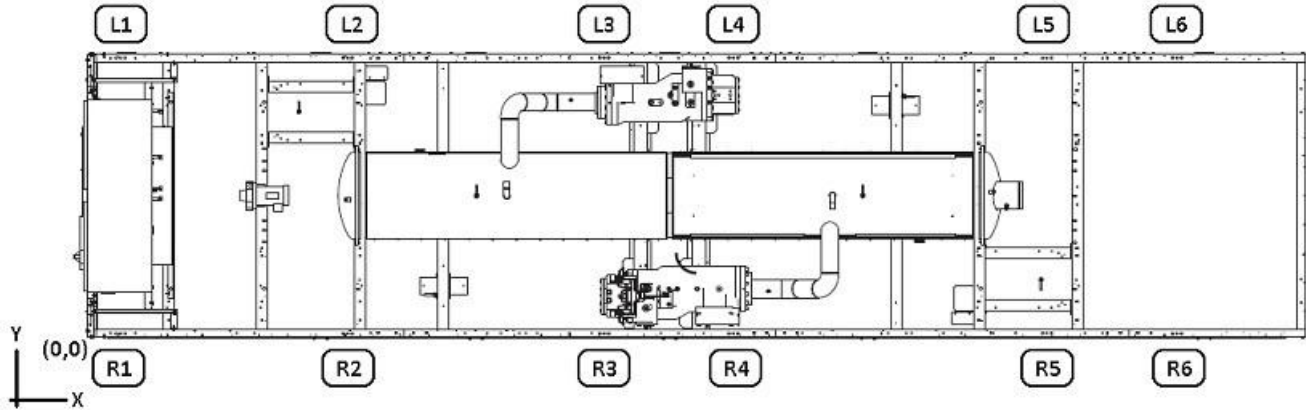

AVM Data						
LOCATION	X Distance [in]	Y Distance [in]	JCI PART NUMBER	SAP NUMBER	COLOUR	Operating Weights [lb]
R1	10.3	1.3	029-25335-002	434004	Brick Red	1172
R2	81.0	1.3	029-25335-004	434005	Charcoal	2414
R3	153.8	1.3	029-25335-004	434005	Charcoal	2635
R4	205.5	1.3	029-25335-004	434005	Charcoal	2635
R5	284.2	1.3	029-25335-004	434005	Charcoal	2891
R6	426.9	1.3	029-25335-002	434004	Brick Red	1088
L1	10.3	87.0	029-25335-002	434004	Brick Red	1157
L2	81.0	87.0	029-25335-004	434005	Charcoal	2396
L3	153.8	87.0	029-25335-004	434005	Charcoal	2626
L4	205.5	87.0	029-25335-004	434005	Charcoal	2626
L5	284.2	87.0	029-25335-004	434005	Charcoal	2943
L6	426.9	87.0	029-25335-002	434004	Brick Red	1088

Weight Data			
Total Weight [lb]		Centre of Gravity [in]	
Shipping Weight [lb]	24587	Xg [in]	201.6
Operating Weights [lb]	25672	Yg [in]	46.1

All values are de-rated by 15% apart from those which have part number. (029-25334-013 and 029-25336-014: 0% de-rated), (029-25335-004: 10% de-rated), (029-25335-001 and 029-25335-003: 25% de-rated)

Air Cooled Screw Liquid Chiller - YORK YVAA R-513A 50Hz & 60Hz

I. GENERAL

a. GENERAL REQUIREMENTS

- i. The requirements of this Section shall conform to the general provisions of the Contract, including General and Supplementary Conditions, Conditions of the Contract, and Contract Drawings.

b. SCOPE

- i. Provide Microprocessor controlled, twin-screw compressor, air-cooled, liquid chillers of the scheduled capacities as shown and indicated on the Drawings, including but not limited to:
 1. Chiller package
 2. Charge of refrigerant and oil
 3. Electrical power and control connections
 4. Chilled liquid connections
 5. Manufacturer start-up

c. QUALITY ASSURANCE

- i. Products shall be Designed, Tested, Rated and Certified in accordance with, and Installed in compliance with applicable sections of the following Standards and Codes:
 1. AHRI 550/590 – Water Chilling Packages Using the Vapor Compression Cycle
 2. AHRI 370 – Sound Rating of Large Outdoor Refrigerating and Air-Conditioning Equipment
 3. ANSI/ASHRAE 15 – Safety Code for Mechanical Refrigeration
 4. ANSI/ASHRAE 34 – Number Designation and Safety Classification of Refrigerants
 5. ASHRAE 90.1 – Energy Standard for Buildings Except Low-Rise Residential Buildings
 6. ANSI/NFPA 70 – National Electrical Code (N.E.C.)
 7. ASME Boiler and Pressure Vessel Code, Section VIII, Division 1
 8. OSHA – Occupational Safety and Health Act
 9. Manufactured in facility registered to ISO 9001
 10. Conform to Intertek Testing Services for construction of chillers and provide ETL/cETL Listed Mark
- ii. Factory Run Test: Chiller shall be pressure-tested, evacuated and fully charged with refrigerant and oil, and shall be factory operational run tested with water flowing through the vessel.
- iii. Chiller manufacturer shall have a factory trained and supported service organization.
- iv. Warranty: Manufacturer shall Warrant all equipment and material of its manufacture against defects in workmanship and material for a period of eighteen (18) months from date of shipment or twelve (12) months from date of start-up, whichever occurs first.

d. DELIVERY AND HANDLING

- i. Unit shall be delivered to job site fully assembled with all interconnecting refrigerant piping and internal wiring ready for field installation and charged with refrigerant and oil by the Manufacturer.
- ii. Provide protective covering over vulnerable components for unit protection during shipment. Fit nozzles and open ends with plastic enclosures.
- iii. Unit shall be stored and handled per Manufacturer's instructions.

II. PRODUCTS

a. MANUFACTURERS

- i. The design shown on the Drawings is based on YORK model YVAA chiller manufactured by Johnson Controls / YORK. Alternate equipment will be acceptable if the manufacturer's equipment meets the scheduled performance and complies with these specifications. If equipment manufactured by a manufacturer other than that scheduled is utilized, then the Mechanical Contractor shall be responsible for coordinating with the General Contractor and all affected Subcontractors to insure proper provisions for installation of the furnished unit. This coordination shall include, but not be limited to, the following:
 1. Structural supports for units.
 2. Piping size and connection/header locations.
 3. Electrical power requirements and wire/conduit and over current protection sizes.
 4. Chiller physical size on plant layout.
 5. Site noise considerations.
- ii. The Mechanical Contractor shall be responsible for all costs incurred by the General Contractor, Subcontractors, and Consultants to modify the building provisions to accept the furnished alternate equipment.
- iii. The equipment manufacturer must specialize in the design and manufacture of the products specified and shall have a minimum of five (5) Years of experience in supplying variable speed driven compressor technology on the type of equipment and refrigerant specified.

b. GENERAL

- i. Description: Furnish, Install, and Commission factory assembled, charged, and operational run tested air-cooled screw compressor chiller as specified herein and shown on the Drawings. Chiller shall include, but is not limited to: a complete system with multiple independent refrigerant circuits, semi hermetic twin screw compressors, shell and tube hybrid falling film type evaporator, air-cooled condenser, R-513A refrigerant, lubrication system, interconnecting wiring, safety and operating controls including capacity controller, control center, motor starting components, and special features as specified herein or required for safe, automatic operation.
- ii. Operating Characteristics:
 1. Provide low and high ambient temperature control options as required to ensure unit is capable of starting and operating from -10°F to 125°F (-23°C to 52°C) ambient temperature.
 2. Provide capacity control system capable of reducing unit capacity to 10% of full load for 2 compressor units. Compressor shall start in unloaded condition. Hot gas bypass shall not be acceptable to meet specified minimum load.
- iii. Cabinet: Unit panels, structural elements, control boxes and heavy gauge structural base shall be constructed of painted galvanized steel. All exposed sheet steel shall be coated with baked on powder paint to meet 500-hour salt spray test in accordance with the ASTM B117 standard.
- iv. Shipping: Unit shall ship in one piece and shall require installer to provide only a single evaporator inlet and outlet pipe connection. If providing chiller model that ships in multiple pieces, bid shall include all the material and field labor costs for factory authorized personnel to install a trim kit to connect the pieces as well as all interconnecting piping and wiring.

c. COMPRESSORS

- i. Compressor Motors: Refrigerant suction-gas cooled accessible hermetic compressor motor, full suction gas flow through 0.006" (0.1524 mm) maximum mesh screen, with inherent internal thermal overload protection and external current overload on all three phases.
- ii. Balancing Requirements: All rotating parts shall be statically and dynamically balanced.
- iii. Lubrication System: External oil separators with no moving parts, 450 psig (31 barg) design working pressure, and ETL listing shall be provided on the chiller. Refrigerant system differential pressure shall provide oil flow through service replaceable, 0.5 micron, full flow, cartridge type oil filter internal to compressor. Filter bypass, less restrictive media, or oil pump not acceptable.
- iv. Capacity Control: Compressors shall start at minimum load. Provide Microprocessor control to command compressor capacity to balance compressor capacity with cooling load.

d. REFRIGERANT CIRCUIT COMPONENTS

- i. Refrigerant: R-513A. Classified as Safety Group A1 according to ASHRAE 34.
- ii. Equipment supplied shall comply with LEED Energy & Atmosphere Credit 4, Enhanced Refrigerant Management.
- iii. Each independent refrigerant circuit shall incorporate all components necessary for the designed operation including: liquid line shut-off valve with charging port, low side pressure relief device, removable core filter-drier and sight glass with moisture indicator.

- iv. Chiller manufacturer shall provide an independent circuit for each compressor to provide maximum redundancy during chiller operation. If equipment does not have independent circuits per compressor, manufacturer shall provide owner one spare compressor of each unique size.
 - v. Discharge lines shall be provided with manual compressor shut-off service valves.
- e. HEAT EXCHANGERS
- i. Evaporator:
 1. Evaporator shall be shell and tube, hybrid falling film type with 2 pass arrangement to optimize efficiency and refrigerant charge. Tubes shall be high-efficiency, internally and externally enhanced type copper tubes with 0.035" (0.89 mm) minimum wall thickness at all intermediate tube supports to provide maximum tube wall thickness at the support area. Each tube shall be roller expanded into the tube sheets providing a leak proof seal, and be individually replaceable. Independent refrigerant circuits shall be provided per compressor.
 2. Constructed, tested, and stamped in accordance with applicable sections of ASME pressure vessel code for minimum 235 psig (16 barg) refrigerant side design working pressure and 150 psig (10 barg) liquid side design working pressure.
 3. Water boxes shall be removable to permit tube cleaning and replacement. Water boxes shall include liquid nozzle connections suitable for ANSI/AWWA C-606 couplings, welding, or flanges.
 4. Provide vent and drain fittings.
 5. Provide thermostatically controlled shell heaters and water box immersion heaters to assist in preventing freeze damage. A separate power connection for evaporator water box heaters is required and shall be provided by the Contractor
 6. Connection location: Chilled liquid inlet and outlet nozzle connections are located at rear (opposite control panel) end of unit.
 - ii. Air-cooled Condenser:
 1. Condenser coils shall be microchannel type, parallel flow aluminum alloy tubes metallurgically brazed as one piece to enhanced aluminum alloy fins. Waterside economizer coil shall be tube and fin type with 3/8 diameter tube for low pressure drop and to avoid clogging. If microchannel economizer coils are provided, contractor is responsible to provide wye-strainer properly sized to avoid economizer coil clogging. Condenser coils shall be designed for 350 psig (24 barg) or higher working pressure. Economizer coils shall be designed for 150 psig (10.3 barg) or higher.
 2. Low Sound Fans with Variable Speed Drives. All fans shall be powered by VSDs. Fans shall provide vertical air discharge from extended orifices. Fans shall be composed of corrosion resistant aluminum hub and glass-fiber-reinforced polypropylene composite blades molded into a low-noise airfoil section. Fan impeller shall be dynamically balanced for vibration-free operation. Fan guards of heavy gauge, PVC (polyvinyl chloride) coated or galvanized steel.
 3. Fan Motors: High efficiency, direct drive, 3-phase, insulation class "F" , current protected, Totally Enclosed Air-Over (TEAO), with double sealed, permanently-lubricated ball bearings. Open Drip Proof (ODP) fan motors will not be acceptable.
- f. INSULATION
- i. Material: Closed-cell, flexible, UV protected, thermal insulation complying with ASTM C 534 Type 2 (Sheet) for preformed flexible elastomeric cellular thermal insulation in sheet and tubular form.
 - ii. Thickness: 3/4 (19mm).
 - iii. Thermal conductivity: 0.26 (BTU/HR-Ft2-°F/in) maximum at 75°F mean temperature.
 - iv. Factory-applied insulation over cold surfaces of liquid chiller components including evaporator shell, water boxes, and suction line. Liquid nozzles shall be insulated by Contractor after pipe installation.
 - v. Adhesive: As recommended by insulation manufacturer and applied to 100 percent of insulation contact surface including all seams and joints.
- g. ACOUSTICAL DATA
- i. Provide acoustical sound power or sound pressure level data in decibels (dB) at the scheduled eight (8) octave band center frequencies. A-weighted sound data alone is not acceptable.
 - ii. Provide all sound power or sound pressure level data at 100%, 75%, 50%, and 25% load.
 - iii. Supplied equipment shall not exceed scheduled sound power or sound pressure level data at any load point. The mechanical Contractor shall be responsible for any additional costs associated with equipment deviation.

- iv. Acoustical performance ratings shall be in accordance with AHRI Standard 370.
- h. POWER AND ELECTRICAL REQUIREMENTS
- i. Power/Control Panel:
 - 1. Factory installed and wired NEMA 3R, powder painted steel cabinets with tool lockable, hinged, latched, and gasket sealed outer doors equipped with wind struts for safer servicing. Provide main power connection(s), compressor starters and fan motor contactors, current overloads, and factory wiring.
 - 2. Panel shall include control display access door.
 - ii. Single Point Power:
 - 1. Provide multiple point power connection to chiller, shall be 3 phase of scheduled voltage.
 - 2. Multiple Point Circuit Breaker: A unit-mounted Circuit Breaker with external lockable handle shall be provided at the point of incoming multiple point connection for field connection, interconnecting wiring to the compressors, and isolating the power voltage for servicing. Incoming power wiring must comply with local codes. Circuit breakers shall be sized to provide the motor branch circuit protection, short circuit protection and ground fault protection for the motor branch-circuit conductors, the motor control apparatus and the motors.
 - iii. Control Transformer: Power panel shall be supplied with a factory mounted and wired control transformer that will supply all unit control voltage from the main unit power supply. Transformer shall utilize scheduled line voltage on the primary side and provide 115V/1Ø on secondary.
 - iv. Short Circuit Withstand Rating of the chiller electrical enclosure shall be (380, 400, & 460V: 65,000 Amps). Rating shall be published in accordance with UL508.
 - v. Motor Starters: Motor starters shall be Variable Frequency Drive type with zero electrical inrush current. Wye-Delta, Solid State, and Across the Line type starters will not be acceptable.
 - vi. Motor Starters: Motor starters shall be zero electrical inrush current (Variable Frequency Drives) or reduced inrush type (Closed transition Wye-Delta or Solid State) for minimum electrical inrush. Open transition Wye-Delta and Across the Line type starters will not be acceptable.
 - vii. Motor Starters: Motor starters shall be Variable Frequency Drive type with zero electrical inrush current. Wye-Delta, Solid State, and Across the Line type starters will not be acceptable.
 - viii. Power Factor:
 - 1. Provide equipment with power factor correction capacitors as required to maintain a displacement power factor of 95% at all load conditions.
 - 2. The installing contractor is responsible for additional cost to furnish and install power factor correction capacitors if they are not factory mounted and wired.
 - ix. All exposed power wiring shall be routed through liquid-tight, UV-stabilized, non-metallic conduit.
 - x. Supplied equipment shall not exceed scheduled Minimum Circuit Ampacity (MCA.) The mechanical Contractor shall be responsible for any additional costs associated with equipment deviation.
- i. CONTROLS
- i. General:
 - 1. Provide automatic control of chiller and waterside economizer operation including compressor start/stop and load/unload, anti-recycle timers, condenser fans, evaporator pump, evaporator heater, waterside economizer bypass valve, unit alarm contacts and run signal contacts.
 - 2. Provide dry contacts for chilled fluid pump control and evaporator shell heaters to assist in preventing freeze damage due to migration of refrigerant at ambient temperatures below 32°C (0°C).
 - 3. Chiller shall automatically reset to normal chiller operation after power failure.
 - 4. Unit operating software shall be stored in non-volatile memory. Field programmed set points shall be retained in lithium battery backed regulated time clock (RTC) memory for minimum 5 years.
 - 5. Alarm contacts shall be provided to remote alert for any unit or system safety fault.
 - ii. Display and Keypad:

1. Provide minimum 80 character liquid crystal display that is both viewable in direct sunlight and has LED backlighting for nighttime viewing. Provide one keypad and display panel per chiller.
 2. Display and keypad shall be accessible through display access door without opening main control/electrical cabinet doors.
 3. Display shall provide a minimum of unit setpoints, status, electrical data, temperature data, pressures, safety lockouts and diagnostics without the use of a coded display.
 4. Descriptions in English (or available language options), numeric data in English (or Metric) units.
 5. Sealed keypad shall include unit On/Off switch.
- iii. Programmable Setpoints (within Manufacturer limits): Display language, chilled liquid cooling mode, local/remote control mode, display units mode, system lead/lag control mode, remote temperature reset, remote current limit, remote sound limit, low ambient temperature cutout enable/disable, leaving chilled liquid setpoint and range, maximum remote temperature reset.
 - iv. Display Data: Chilled liquid leaving and entering temperatures; outside ambient air temperature; lead system; evaporator pump status; active remote control; compressor suction, discharge, and oil pressures per refrigerant circuit; compressor discharge, motor, and oil temperatures per refrigerant circuit; saturation temperatures per refrigerant circuit; compressor speed; condenser fan status; condenser subcooling temperature; condenser drain valve percentage open; compressor capacity in percentage of Full Load Amps; compressor number of starts; run time; operating hours; evaporator heater status; history data for last ten shutdown faults; history data for last 20 normal (non-fault) shutdowns.
 - v. Predictive Control Points: Unit controls shall avoid safety shutdown when operating outside design conditions by optimizing the chiller controls and cooling load output to stay online and avoid safety limits being reached. The system shall monitor the following parameters and maintain the maximum cooling output possible without shutdown of the equipment: motor current, suction pressure, discharge pressure, starter internal ambient temperature, and starter baseplate temperature.
 - vi. System Safeties: Shall cause individual compressor systems to perform auto-reset shut down if: high discharge pressure or temperature, low suction pressure, low motor current, high/low differential oil pressure, low discharge superheat, high motor temperature, system control voltage.
 - vii. Unit Safeties: Shall be automatic reset and cause compressors to shut down if: high or low ambient temperature, low leaving chilled liquid temperature, under voltage, flow switch operation. Contractor shall provide flow switch and wiring per chiller manufacturer requirements.
 - viii. Manufacturer shall provide any controls not listed above, necessary for automatic chiller operation. Mechanical Contractor shall provide field control wiring necessary to interface sensors to the chiller control system.
- j. ACCESSORIES AND OPTIONS
- i. Some accessories and options supersede standard product features. All options are factory-mounted unless otherwise noted.
 - ii. CONTROLS OPTIONS:
 1. Building Automation System Interface: Chiller to accept BACnet MS/TP, N2 and Modbus protocol from BAS (by others). BACnet to be BACnet Testing Laboratories (BTL) listed and support BACnet Automatic Discovery to eliminate field commissioning of chiller controls.
 - iii. GENERAL OPTIONS:
 1. Vibration Isolation (All Options Field Mounted by Contractor):
 - a. Provide Elastomeric Isolators.

III. EXECUTION

a. INSTALLATION

- i. General: Rig and Install in full accordance with Manufacturer' s requirements, Project drawings, and Contract documents.
- ii. Location: Locate chiller as indicated on drawings, including cleaning and service maintenance clearance per Manufacturer instructions. Adjust and level chiller on support structure.
- iii. Components: Installing Contractor shall provide and install all auxiliary devices and accessories for fully operational chiller.
- iv. Electrical: Coordinate electrical requirements and connections for all power feeds with Electrical Contractor.
- v. Controls: Coordinate all control requirements and connections with Controls Contractor.

- vi. Finish: Installing Contractor shall paint damaged and abraded factory finish with touch-up paint matching factory finish.

CERTIFICATE OF LIMITED WARRANTY

JOHNSON CONTROLS EQUIPMENT

Contract Number: 5E600031
Ship Date:

Model No.: YVAA0500
Start Date:

Serial Number:

POLICY STATEMENT

Johnson Controls (JCI) warrants all equipment and associated factory supplied materials or start-up services performed by Johnson Controls in connection therewith, against defects in workmanship and material. **The warranty period begins at start up, or six (6) months from the ship date, whichever occurs first.** Subject to the exclusions listed below, Johnson Controls, at its option, will repair or replace, FOB point of shipment, such products or components as it finds defective.

Except for reciprocating replacement compressors, which Johnson Controls warrants for a period of twelve (12) months from date of shipment, Johnson Controls warrants Johnson Controls reconditioned or replacement materials, or installation or start-up services performed by Johnson Controls in connection therewith, against defects in workmanship and material for a period of (90) days from date of shipment.

The above represents the minimum warranty policy Johnson Controls will extend to customers. Additional product specific coverage is provided as outlined herein or in separate related warranty policies. No warranty repairs or replacements will be made until payment for all equipment, materials, components, or services has been received by Johnson Controls.

Warranty Type	Warranty Duration	Expiration Date
Standard - Entire Unit - Parts and Labor	1 Year	Not provided

EXCLUSIONS:

Unless specifically agreed to in the contract documents, or associated with additional warranty options listed above, this warranty does not include the following costs and expenses:

- I. Labor to repair, remove, or reinstall any equipment, materials or components.
- II. Special shipping, handling or transportation charges, including cranes, safety walks or other safety requirements specific to jobsites.
- III. Cost of refrigerant.
- IV. Freight damage.
- V. Field applied coatings added to any surface or heat exchanger.
- VI. Rental chillers.
- VII. Normal wear and tear or corrosion.

ALL WARRANTIES ARE VOID IF:

- A. Equipment is used with refrigerants, oil, additives, or antifreeze agents other than those authorized by supplying factory.
- B. Equipment is used with any material or any equipment such as evaporators, tubing, other low side equipment or refrigerant controls not approved by supplying factory.
- C. Equipment has been damaged by freezing because it was not properly protected during cold weather or damaged by fire or any other conditions not ordinarily encountered.
- D. Equipment is not applied, installed, operated, maintained and serviced in accordance with instructions issued by Johnson Controls.
- E. Equipment is damaged due to dirt, air, moisture, or other foreign matter entering the refrigerant system.
- F. Equipment is not properly stored, protected, or inspected by customer during the period from date of shipment to date of initial start-up.

- G. Field coating of coil has occurred.
- H. Equipment is damaged due to acts of God, abuse, including shipping damage, neglect, sabotage, or acts of terrorists.
- I. Equipment has modifications carried out that have an effect on the original design of the product without such work being authorized by the factory. Any on site design changes or unit modification/replacement shall be authorized in advance by the factory.
- J. Equipment is moved from the location where it is originally placed in service, unless performed by certified Johnson Controls employees who have followed Johnson Controls' then-current installation and operations procedures as evidenced by signed start-up documentation.

THIS WARRANTY IS IN LIEU OF ALL OTHER WARRANTIES AND LIABILITIES, EXPRESS OR IMPLIED IN LAW OR IN FACT, INCLUDING THE WARRANTIES OF MERCHANTABILITY AND FITNESS FOR A PARTICULAR PURPOSE. THE WARRANTIES CONTAINED HEREIN SET FORTH BUYER' S SOLE AND EXCLUSIVE REMEDY IN THE EVENT OF A DEFECT IN WORKMANSHIP OR MATERIALS. IN NO EVENT SHALL JOHNSON CONTROLS' LIABILITY FOR DIRECT OR COMPENSATORY DAMAGES EXCEED THE PAYMENTS RECEIVED BY JOHNSON CONTROLS FROM BUYER FOR THE MATERIAL OR EQUIPMENT INVOLVED, NOR SHALL JOHNSON CONTROLS BE LIABLE FOR ANY SPECIAL, INCIDENTAL, OR CONSEQUENTIAL DAMAGES. THESE LIMITATIONS ON LIABILITY AND DAMAGES SHALL APPLY UNDER ALL THEORIES OF LIABILITY OR CAUSES OF ACTION, INCLUDING BUT NOT LIMITED TO, CONTRACT, WARRANTY, TORT, (INCLUDING NEGLIGENCE) OR STRICT LIABILITY. THE ABOVE LIMITATIONS SHALL INURE TO THE BENEFIT OF JOHNSON CONTROLS SUPPLIERS AND SUBCONTRACTORS.

Products furnished, but not manufactured, by Johnson Controls are not covered by this warranty. Products furnished but not manufactured by Johnson Controls may be covered by the manufacturer of such products and Buyer's sole and exclusive remedy for such products is limited to any warranty given by said manufacturer.

To qualify for warranty consideration under this Johnson Controls warranty, Buyer must immediately notify Johnson Controls at the earlier of the Buyer's discovery of the defect or the time at which the Buyer should have discovered the defect with the exercise of due diligence. Buyer must also promptly thereafter return to Johnson Controls (freight pre-paid by Buyer) all defective parts. Nothing herein is intended to provide warranty coverage to lessees or anyone other than Buyer and no third-parties are intended to be beneficiaries of this Limited Warranty.

If you are interested in adding additional coverage, contact your local JCI branch for more information about extended warranty.

The extended warranty is in accordance with BE Global Intercompany Equipment Warranty Policy 17-16.101.BEQ.

Customer Signature: _____

Johnson Controls Representative: _____

Date: _____



STANDARD LIMITED WARRANTY ENGINEERED SYSTEMS EQUIPMENT

SERVICE POLICY

Supersedes: 50.05-NM2 (812)

Form 50.05-NM2 (1212)

POLICY STATEMENT

Johnson Controls (JCI) warrants all equipment and associated factory supplied materials or start-up services performed by Johnson Controls in connection therewith, against defects in workmanship and material for a period of eighteen (18) months from date of shipment, or twelve (12) months from date of start up, whichever occurs first. Subject to the exclusions listed below, Johnson Controls, at its option, will repair or replace, FOB point of shipment, such products or components as it finds defective.

Except for reciprocating replacement compressors, which Johnson Controls warrants for a period of twelve (12) months from date of shipment, Johnson Controls warrants Johnson Controls reconditioned or replacement materials, or installation or start-up services performed by Johnson Controls in connection therewith, against defects in workmanship and material for a period of (90) days from date of shipment.

The above represents the minimum warranty policy Johnson Controls will extend to customers. Additional product specific coverage is provided as outlined in related warranty policies. No warranty repairs or replacements will be made until payment for all equipment, materials, or components has been received by Johnson Controls.

EXCLUSIONS:

Unless specifically agreed to in the contract documents, this warranty does not include the following costs and expenses:

1. Labor to remove or reinstall any equipment, materials or components.
2. Shipping, handling or transportation charges, including cranes, safety walks or other safety requirements specific to jobsites.
3. Cost of refrigerant.
4. Freight damage.
5. Field applied coatings added to any surface or heat exchanger
6. Rental Chillers.

ALL WARRANTIES ARE VOID IF:

1. Equipment is used with refrigerants, oil, additives, or antifreeze agents other than those authorized by supplying factory.
2. Equipment is used with any material or any equipment such as evaporators, tubing, other low side equipment or refrigerant controls not approved by supplying factory
3. Equipment has been damaged by freezing because it was not properly protected during cold weather or damaged by fire or any other conditions not ordinarily encountered.
4. Equipment is not installed, operated, maintained and serviced in accordance with instructions issued by Johnson Controls.
5. Equipment is damaged due to dirt, air, moisture, or other foreign matter entering the refrigerant system.
6. Equipment is not properly stored, protected, or inspected by the customer during the period from date of shipment to date of initial start-up.
7. Field coating of coil has occurred.
8. Equipment is damaged due to acts of god, abuse, including shipping damage, neglect, sabotage, or acts of terrorists.
9. Equipment has modifications carried out that have an effect on the original design of the product without such work being authorized by the factory. Any on site design changes or unit modification/replacement shall be authorized in advance by the factory.

THIS WARRANTY IS IN LIEU OF ALL OTHER WARRANTIES AND LIABILITIES, EXPRESS OR IMPLIED IN LAW OR IN FACT, INCLUDING THE WARRANTIES OF MERCHANTABILITY AND FITNESS FOR A PARTICULAR PURPOSE. THE WARRANTIES CONTAINED HEREIN SET FORTH BUYER'S SOLE AND EXCLUSIVE REMEDY IN THE EVENT OF A DEFECT IN WORKMANSHIP OR MATERIALS. IN NO EVENT SHALL JOHNSON CONTROLS' LIABILITY FOR DIRECT OR COMPENSATORY DAMAGES EXCEED THE PAYMENTS RECEIVED BY JOHNSON CONTROLS FROM BUYER FOR THE MATERIAL OR EQUIPMENT INVOLVED, NOR SHALL JOHNSON CONTROLS BE LIABLE FOR ANY SPECIAL, INCIDENTAL, OR CONSEQUENTIAL DAMAGES. THESE LIMITATIONS ON LIABILITY AND DAMAGES SHALL APPLY UNDER ALL THEORIES OF LIABILITY OR CAUSES OF ACTION, INCLUDING BUT NOT LIMITED TO, CONTRACT, WARRANTY, TORT, (INCLUDING NEGLIGENCE) OR STRICT LIABILITY. THE ABOVE LIMITATIONS SHALL INURE TO THE BENEFIT OF JOHNSON CONTROLS SUPPLIERS AND SUBCONTRACTORS.





Equipment Release Approval Form

SUBMITTAL NOTES

Product Type: YVAA - Air-Cooled Chiller

Unit Tags: CH-1

The following table must be completed prior to releasing the equipment for fabrication. Please initial the column indicating the information contained in this submittal has been verified, or indicate to refer to a marked-up page.

SUBMITTAL VERIFICATION	
	Purchaser Initials
Electrical voltage and electrical connections are compatible with jobsite requirements.	
Piping / Ductwork connections shown in this submittal are correct .	
Unit tag designations are correct.	
Equipment dimensions (length, width, and height) and weights have been verified to comply with jobsite conditions and rigging requirements. Please indicate approval by your initials on all included drawings.	
Verify "Unit Hand" of any Air Handling Equipment per the definition provided on the " Equipment Release / Configuration Process " form.	



SUBMITTAL VERIFICATION	
	Purchaser Initials
Indicate equipment configuration choices on the Equipment Release /Configuration Process form (if included on this Submittal package), and sign the form.	

Important Notes:

- 1) Actual fabrication release cannot commence until this form is signed by the customer and returned to JCI along with a release notification want date and ship to address.
- 2) Equipment "lead-time" does not start until confirmed release documentation is received, and the order is actually released to the factory.
- 3) Modifications to equipment configurations after fabrication release may impact cost and lead-time
- 4) Attached configurations are as shown in the approved equipment submittals or as defined in superseding customer correspondence.
- 5) AHU "Side" / "Hand" orientation is relative to a person standing inside an AHU with air hitting the back of the head.
- 6) Note that once this document is confirmed, the equipment configurations defined by this document take precedence over all other documents.
- 7) "Want date" and/or "ship to address" changes made after this document is confirmed may impact cost and lead-time.
- 8) Air handler drawings also include shipping split explosions with corresponding weights and dimensions. If additional splits are required, there will be additional costs and the unit length will increase.



Please fill out the following table and refer to the receiving/rigging instructions in this submittal to help ensure a smooth delivery and installation of the equipment.

DELIVERY INFORMATION	
	Please fill out information below
Contact name for coordinating delivery of equipment with transportation company	
Contact phone number	
Advance notice required from transportation company prior to delivering equipment (typically 48 hours)	
Ship to address:	
Other special shipping instructions or requirements	



CUSTOMER APPROVAL:

Customer
Name: _____

Signature (*) _____

Date: _____