

KIG

INSTRUCTION MANUAL

INSTALLATION * OPERATION
WARRANTY

- 1. All systems must have a minimum of + 10°F freeze protection using inhibited Propylene Glycol. See page 8 for details.**
- 2. See Product label for minimum circuit ampacity and maximum fuse size. See page 1 for label location.**
- 3. Supply and Return pipe size is crucial. See page 7 for details.**
- 4. Use copper or schedule 80 CPVC ONLY for supply and return lines.**
- 5. DO NOT EXTEND CONTROL WIRE supplied with the digital temperature controller. Extending the control wire will create a voltage drop and chatter the compressor contactor(s). Refer to “Extending Control Module Cable” section if temperature module cable must be extended.**

PART NUMBER

006909

MODEL

WCDCP30438

REVISION

A

OPTIONS

NONE

MOPD

130

KIG

INSTRUCTION MANUAL

INSTALLATION * OPERATION
WARRANTY

WATER CHILLER

Style: DC Packaged
Tons: 30
Volt: 460V
Phase: 3 Phase
Refrigerant: R-410A

<u>PART NUMBER</u>	<u>MODEL</u>	<u>REVISION</u>	<u>OPTIONS</u>
006909	WCDCP30438	A	None



KIG
KEITH INDUSTRIAL GROUP, INC.

104 Sterling St, Clinton
MA 01510, USA

Ph: 978-514-3800 e-mail: info@kigsales.com
www.kigsales.com

K I G P R O D U C T S I N S T R U C T I O N M A N U A L

TABLE OF CONTENT	PAGE
Receiving And Unpacking	1
Model & Serial Number	1
30 Ton Unit Location	2
30 Ton Unit Dimensions	2
Electrical Connection & Control Circuit	3
Temperature Control Module	4
Temperature Control Module Adjustment.....	4
Electrical & Temperature Control Module Connections.....	5
Electrical Diagram Without Hot Gas By-Pass....(See Attachment)	6
Chiller Water Piping Connections	7
Chiller Water Piping Connections Continued.....	8
Water Supply Tank	9
Inhibited Propylene Glycol Protection.....	10
Operation – Start / Shut-Down	11
Refrigeration System	12
Controls And Safety Devices	13
Periodic Preventative Maintenance	14
Warranty	14
Replacement Parts – 30 Package Chiller	15

ATTACHMENT – ELECTRICAL DIAGRAM

Receiving And Unpacking

- A. When delivered, the equipment should be carefully inspected. All visible damage and shortages **MUST** be properly noted on freight bill.
- B. While uncrating, if evidence of concealed damage is discovered, set the equipment aside and notify the delivering transportation company immediately.
- C. FREIGHT DAMAGE CLAIMS ARE THE RESPONSIBILITY OF THE PURCHASER. Transportation regulations require that transit damage claims be made within 48 hours after delivery.

Model & Serial Number

Record your Model and Serial Numbers on the Invoice or Sales Receipt.

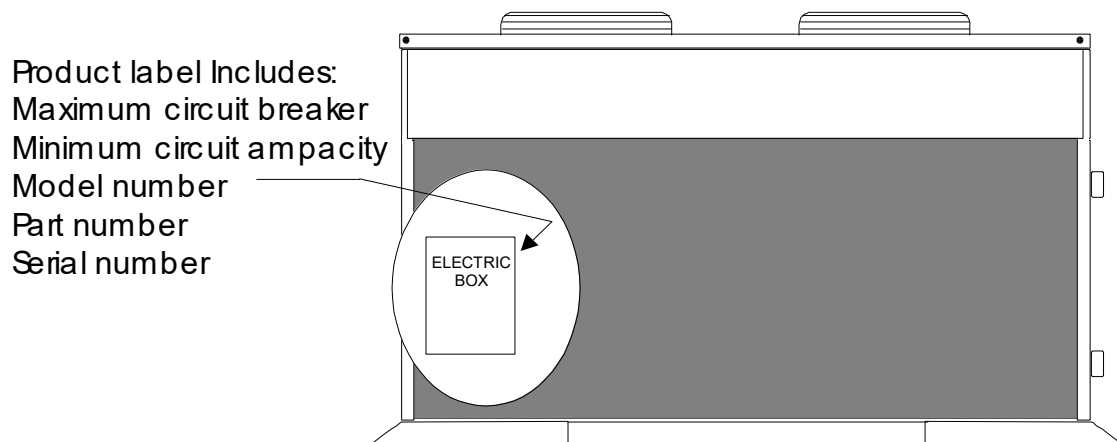

30 Ton Unit Location

- A. For the most efficient operation, locate the chiller in a clean and well ventilated environment.
- B. Do **NOT** install unit in a confined area where recirculation of discharge air may occur. Condenser air is exhausted from top of unit. There must be no overhead obstruction.
- C. Air intake is from either side of unit. One side must be free of obstruction. The other may be placed close to a wall but leave enough room for service access.
- D. Do **NOT** locate unit where heat, lint or exhaust fumes are discharged on the unit.
- E. Place unit in suitable location, level and stabilize unit.

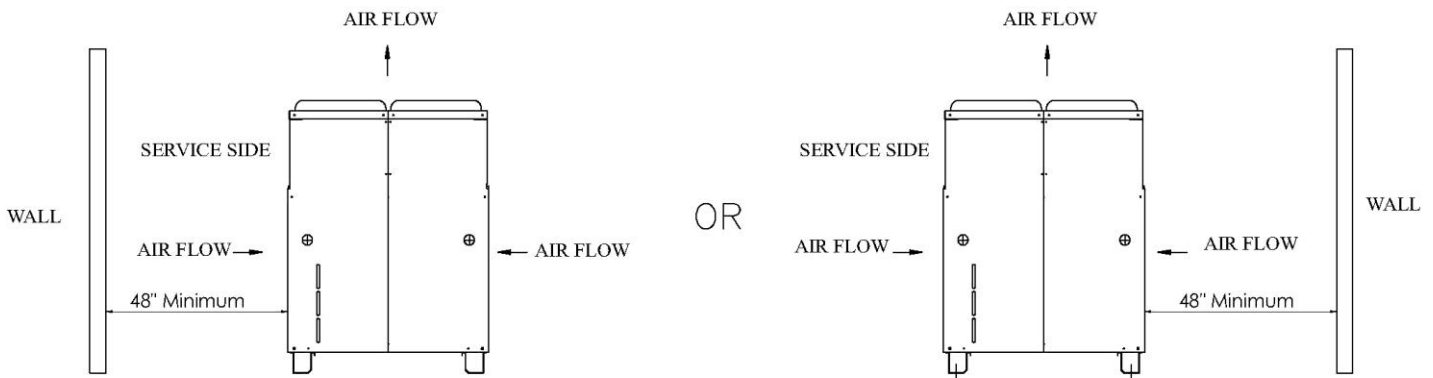

30 Ton Unit Dimensions

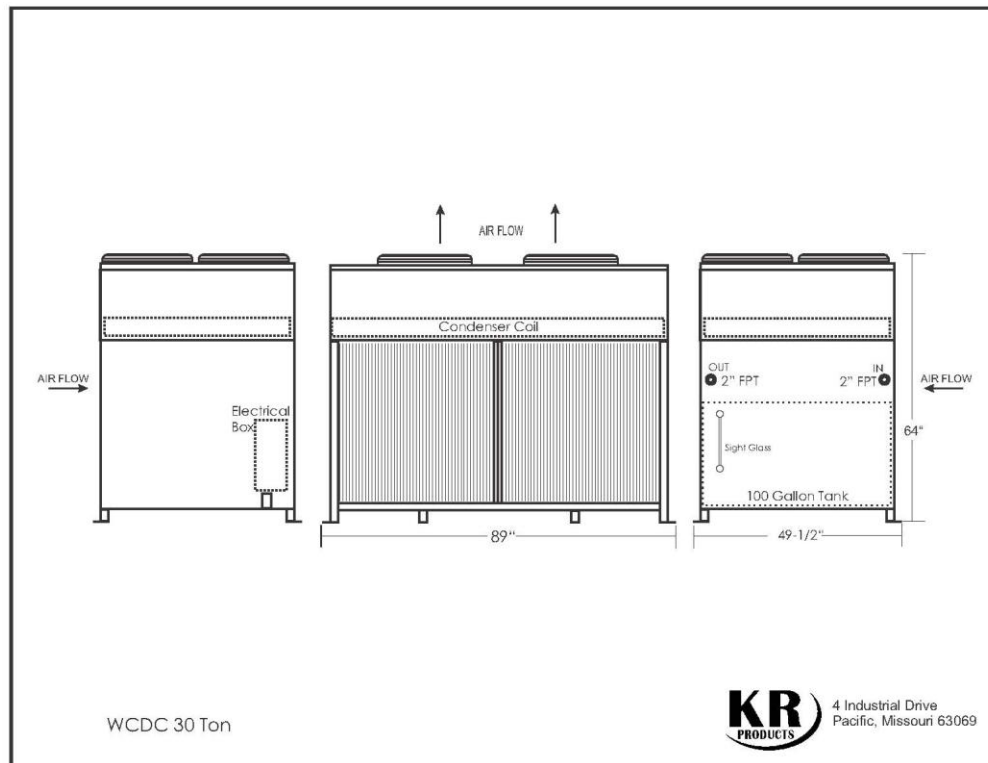

WDC30 30 Ton

KR
PRODUCTS
4 Industrial Drive
Pacific, Missouri 63069

Electrical Connection & Control Circuit

Use Copper Supply Wires Only Use Conductors Suitable For At Least 75°C or 167°F

- A. Electrical power supply requirement for chiller units are identified on the equipment data plate. Determine the plant's voltage supply is the same as the unit's voltage requirements. **See Page 5, and Electrical Diagram Attachment.**
- B. Customer to supply copper wire and conductor wire cable, fused disconnect. The fused disconnect should be sized and installed according to the unit's power supply requirements and local electrical codes.
- C. Provide a separate protected power source and equipment ground consistent with minimum circuit ampacity, maximum fuse, voltage and frequency requirements as stated on unit's data plate.
- D. All Water Chiller Units are equipped with compressor crankcase heater. While the compressor is idle, the crankcase heater prevents refrigerant from migrating to the compressor crankcase. If refrigerant is allowed to condense in the crankcase, it can be drawn into the cylinders upon start up. This can cause damage to the connecting rods, pistons, and valve plates.

IMPORTANT: BEFORE THE UNIT IS STARTED, THE POWER SUPPLY SHOULD BE ENERGIZED TO THE UNIT FOR AT LEAST 12 HOURS, OR THE BOTTOM OF THE COMPRESOR IS WARM TO THE TOUCH.

THIS POWER SOURCE SHOULD BE SEPARATE AND MUST BE ENERGIZED AT ALL TIMES. THE COMPRESSOR HEATER MUST REMAIN ON CONSTANTLY.

If the power has been disconnected more than two hours, the power should be applied for six hours before restarting. Power should be applied to the unit continuously, except for service purposes. The crankcase heater should be checked for proper operation on a regular basis.

- E. **WARNING ON INITIAL START-UP CHECK ROTATION OF COMPRESSOR.** Correct rotation of compressor must be confirmed. If unit is noisy on start-up, shut down immediately. Switch main contactor leads L1 and L3 and restart. Damage to compressor caused by improper rotation is not covered under warranty.
- F. This Chiller is equipped with a 3 phase pump. Three phase motors can rotate in either direction. The pump will operate properly only in one direction (clockwise when looking from the motor end, counter-clockwise when viewed from the pump end). **Operating the pump in the reverse rotation may cause the impeller to unscrew, breaking the shaft, damaging the pump and/or the motor and voids the warranty.**
- G. To **check rotation**, you must observe the motor shaft from the back of the motor. Remove the end cover from the back of the motor and watch the shaft rotation as it slows down. Motor shaft should be turning in the clockwise direction when viewed from the back of the motor. If your three-phase motor is turning tin the wrong direction, interchange any two of the three motor power wires. This should reverse the rotation.

Temperature Control Module

- A. This Chiller is equipped with a Remote Digital Temperature Control Module.
- B. Do NOT extend the 30 foot supplied cable. Extending the cable beyond 30 feet will result in a control voltage drop causing compressor contactor chattering.
- C. Mount the Temperature Control Module securely on the wall, so the temperature readings and the on/off switch are readily accessible.
- D. Connect Temperature Control Module cable to terminal strip in electrical box. Be sure to match color codes wires. See Electrical Page 5.
- E. Secure the lines between the Remote Temperature Control Module and the Chiller unit to walls or stationary supports.

Extending Control Module Cable

OPTION 1

- A. The control module is supplied with 30 feet of color coded cable. Four wires of the cable are the 24 A.C. control circuit and two of the wires are for the temperature sensor. (See wiring diagram for color codes).
- B. The two temperature sensor wires maybe extended up to 100 feet using 18 gauge copper wire. The temperature sensor is not polarity sensitive.
- C. The 24 A.C. control circuit wires may be extended up to 100 feet using 14 gauge stranded copper wire.

OPTION 2

- A. The temperature control module is a Nema 4X box.
- B. The module may be mounted in the water chiller cabinet.
- C. **DO NOT MOUNT TEMPERATURE MODULE TO THE MAIN ELECTRICAL BOX.**

Temperature Control Module Adjustment

- A. DO NOT HOLD SET BUTTON. Holding this set button for more than 3 seconds will re-program the temperature control causing the Water Chiller to **MALFUNCTION**.
- B. To display "CUT-OUT WATER TEMPERATURE" push set button and release immediately. The display should show **SP**. Press set button once to display cut out temperature. To change cut out press the up or down button. When desired setting is reached press set button to enter setting. **SP** will appear. Press the SET and DOWN button simultaneously to return module to normal function.

Code	Display Messages
000	Open probe
- - -	Short-circuited probe
Err	Memory reading error

Electrical & Temperature Control Module Connections

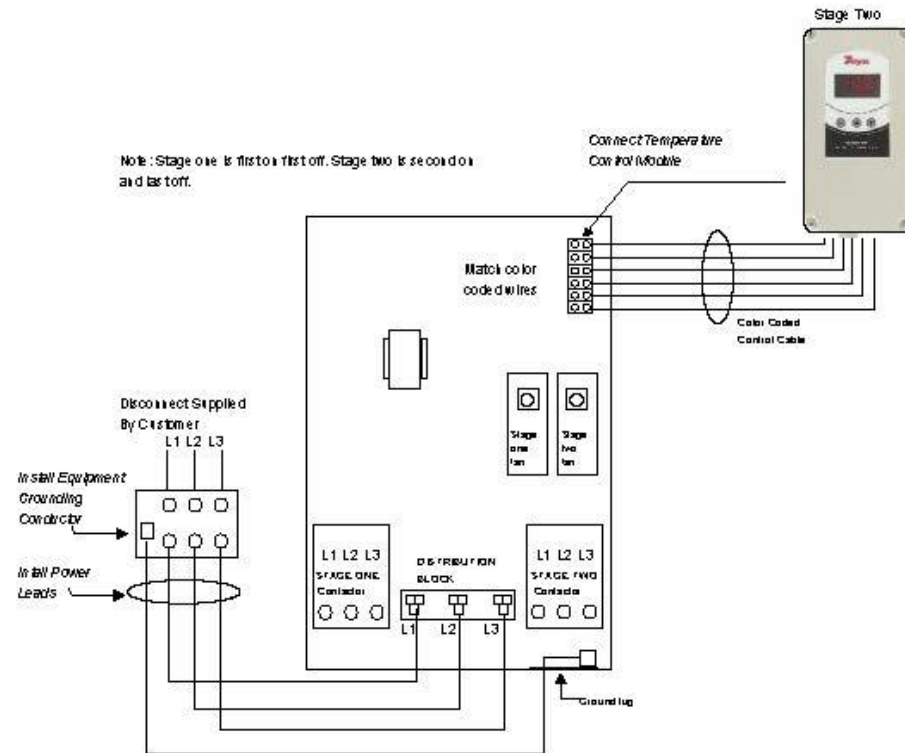

Electrical Diagram

**SEE ELECTRICAL DIAGRAM
ON LAST PAGE OF THIS
MANUAL**

P 30 006909 460V REV A 12.12.22

Chiller Water Piping Connections

- A. KIG Products Chillers require 2.4 gallons per minute ($\pm 20\%$) per rated ton. Example: 30 ton Chiller x 2.4 gpm = 72 gpm. Select proper size pipe based on chart below. In this case 2.5" pipe would be the minimum pipe size. Pipe runs more than 50 feet require a larger pipe size.

SIZING PIPE CHART						
PIPE	GPM		PIPE	GPM	PIPE	GPM
1/2"	2		1-1/2"	30	4"	320
3/4"	5		2"	50	5"	600
1"	10		2-1/2"	90	6"	900
1-1/4"	20		3"	160	8"	2000

- B. Install provided INLINE STRAINER on inlet side of chiller.
- C. Use copper or Schedule 80 CPVC pipe to connect water lines as shown in piping diagram.

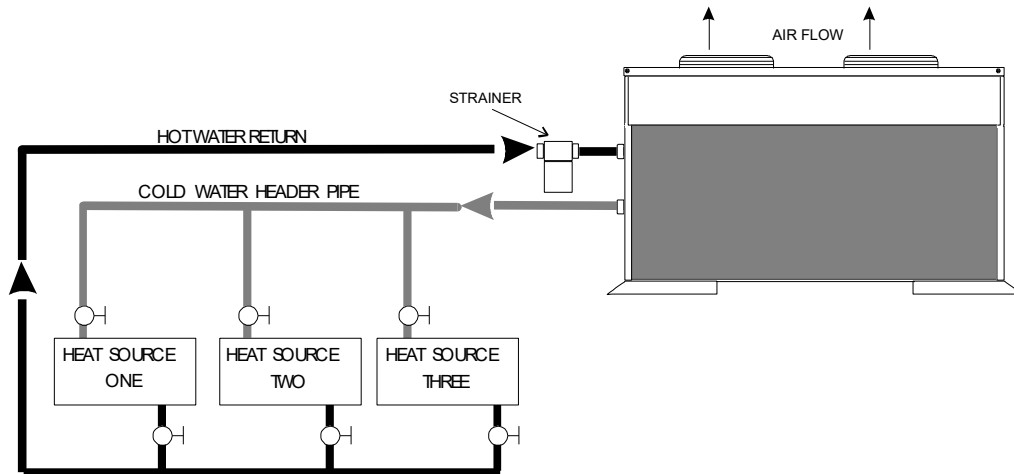

- D. To ensure proper control and ease of maintenance, make sure there is a valve at the water entrance and exit of each piece of equipment being chilled.
- E. Thermometers should be placed in exit water lines to check the amount of cooling taking place in the equipment being chilled.
- F. Support all pipes from sagging to prevent any breakage or leaks.

Chiller Water Piping Connections Continued

- G. Insulate all chilled water lines to prevent sweating and efficiency loss.
- H. FREEZE-DAMAGE DUE TO IMPROPER INSTALLATION PIPING AND/OR LACK OF INHIBITED PROPYLENE GLYCOL IS NOT COVERED BY THE WARRANTY.
- I. **DO NOT OPERATE PUMP WITHOUT WATER. FILL CHILLER WATER TANK WITH THE PROPER INHIBITED PROPYLENE GLYCOL WATER MIXTURE.** Observe water level through front water tank wall.

Regardless Of Ambient Conditions All Chillers Require An Inhibited Propylene Glycol Solution Protection.

- J. A minimum of 30% inhibited propylene glycol and 70% water solution is required for all chillers regardless of ambient conditions. This solution will help protect the internal piping and heat exchanger from rusting and contamination. In addition, the solution will prevent damage to the heat exchanger if the compressor contactor sticks in the closed position.
- K. **Chillers exposed to low ambient conditions require an increased percentage of inhibited propylene glycol.**

DO NOT EXCEED 50% INHIBITED PROPYLENE GLYCOL

It is suggested to test propylene Glycol before start up to ensure proper temperature protection. If you do not have a refractometer tester or equivalent one must be purchased.

PROPYLENE GLYCOL CAPACITY CORRECTION FACTOR TABLE

% PROPYLENE GLYCOL BY WEIGHT	15%	20%	25%	30%	35%	40%	50%
FREEZING POINT IN °F	24°	18°	15°	9°	5°	-5°	-30°
CAPACITY FACTOR MULTIPLIER	0.922	0.986	0.972	0.960	0.950	0.928	0.878
PRESSURE DROP MULTIPLIER	1.04	1.08	1.13	1.21	1.26	1.47	2.79

At standard ARI 590 conditions: 54°F entering fluid temperature, 44° leaving fluid temperature, 95° ambient temperature, 0.0005 fouling

Water Supply Tank

- A. Make sure pump water tank has adequate supply of water before starting pump. Note water level through tank wall.
- B. **Manual make-up of water is required. Additional ANTI-FREEZE must be added to the system to prevent any dilution by make-up water.**
- C. **Automotive Antifreeze has the wrong inhibitors** for water chiller systems. It contains silicate-based inhibitors, which tend to coat heat exchange surfaces and reduce energy efficiency. The Automotive antifreeze can gel or plug the system and reduce the life of pump seals. KIG Products recommends our P/N: 002653 Antifreeze, designed specifically for use in water cooling systems.
- D. The KIG Products Chiller is equipped with a safety water flow switch. If the water flow is restricted due to a plugged INLINE strainer screen or freezing conditions, the unit will automatically shut-down. De-energize unit. Determine cause of condition and correct it before restarting unit.

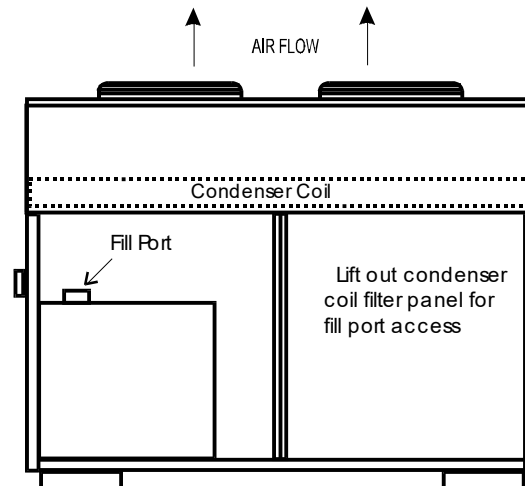

Inhibited Propylene Glycol Protection

- A. Freeze-damage due to improper installation piping and/or lack of anti-freeze is NOT covered by the warranty. The WATER CHILLER Unit **ABSOLUTELY REQUIRES FREEZE PROTECTION.**
- B. **Automotive Antifreeze has the wrong inhibitors** for water chiller systems. It contains silicate-based inhibitors, which tend to coat heat exchange surfaces and reduce energy efficiency. The Automotive antifreeze can gel or plug the system and reduce the life of pump seals. KIG Products recommends our part number 002653 Antifreeze, designed specifically for use in water cooling systems.
- C. Manual make-up of water is required. Additional Inhibited Propylene Glycol must be added to the system to prevent any dilution by make-up water.

DO NOT EXCEED 50% INHIBITED PROPYLENE GLYCOL

It is suggested to test propylene Glycol before start up to ensure proper temperature protection. If you do not have a refractometer tester or equivalent one must be purchased.

PROPYLENE GLYCOL CAPACITY CORRECTION FACTOR TABLE

% PROPYLENE GLYCOL BY WEIGHT	15%	20%	25%	30%	35%	40%	50%
FREEZING POINT IN °F	24°	18°	15°	9°	5°	-5°	-30°
CAPACITY FACTOR MULTIPLIER	0.922	0.986	0.972	0.960	0.950	0.928	0.878
PRESSURE DROP MULTIPLIER	1.04	1.08	1.13	1.21	1.26	1.47	2.79

At standard ARI 590 conditions: 54°F entering fluid temperature, 44° leaving fluid temperature, 95° ambient temperature, 0.0005 fouling

Operation – Start / Shut-Down

- A. Chiller system must be filled with proper amount of Inhibited Propylene Glycol mixture. Do not run pump dry. See Page 10.
- B. **STARTING-UP OPERATIONS** - the power supply to unit must be on 24 hours prior to compressor start-up.

WARNING! THIS COMPRESSOR CONTAINS AN OIL HEATER. POWER SUPPLY MUST BE TURNED ON AT ALL TIMES. IF POWER IS OFF FOR AS MUCH AS 6 HOURS POWER SUPPLY TO UNIT MUST BE RESTORED FOR 12 HOURS BEFORE COMPRESSOR IS STARTED. FAILURE TO DO SO WILL DAMAGE COMPRESSOR.

- C. **WARNING ON INITIAL START-UP CHECK ROTATION OF COMPRESSOR.** Correct rotation of compressor must be confirmed. If unit is noisy on start-up, shut down immediately. Switch main contactor leads L1 and L3 and restart. Damage to compressor caused by improper rotation is not covered under warranty.
- D. Compressor is equipped with auto-reset current overload protector. If unit kicks out on overload it may require one-half hour to three hours to cool and reset.
- E. When **STARTING-UP OR SHUTTING-DOWN** the unit for the day use the SWITCH on the TEMPERATURE CONTROL MODULE. Remember the Water Chiller must remain energized except for servicing.
- F. Clean lint from inlet filters often. Vacuum or wash filters thoroughly as needed. Lack of proper cleaning will reduce efficiency and can cause compressor to kick out on overload, particularly on hot days.
- G. This Chiller is equipped with a 3 phase pump. Three phase motors can rotate in either direction. The pump will operate properly only in one direction (clockwise when looking from the motor end, counter-clockwise when viewed from the pump end). **Operating the pump in the reverse rotation may cause the impeller to unscrew, breaking the shaft, damaging the pump and/or the motor and voids the warranty.**
- H. To **check rotation**, you must observe the motor shaft from the back of the motor. Remove the end cover from the back of the motor and watch the shaft rotation as it slows down. Motor shaft should be turning in the clockwise direction when viewed from the back of the motor. If your three phase motor is turning in the wrong direction, interchange any two of the three motor power wires. This should reverse the rotation

Refrigeration System

- A. This unit is pre-piped, pre-charged and tested at KIG Products.
- B. To avoid High Head Pressure on the water chiller check items below:
 - 1. Very Hot Ambient Temperatures
 - 2. Clogged or Blinded Condenser Coils
 - 3. Overcharge of Refrigerant
 - 4. Undersized Chiller
- I. When unit is operation at 100% capacity the sight glass should appear clear with no foam or bubbles evident. If foam or bubbles appear after the compressor has cycled this indicates low refrigerant charge. A qualified refrigeration technician should check this.
- J. The “dot” in the center of the sight glass is a moisture indicator. It should appear green at all times. A white or yellow color indicates presence of moisture. If the sight glass “dot” is **not** green turn the unit off immediately. Have the unit serviced by a qualified refrigeration technician.

Controls And Safety Devices

A. COMPRESSOR OIL HEATER

This compressor contains an oil heater. The power source to this control must be energized at all times or compressor failure will result.

B. WATER FLOW SAFETY SWITCH

The KIG Products Chiller is equipped with a Safety Water Flow Switch in the OUTLET water line. If the water flow is restricted due to a plug or freezing conditions, the unit will automatically shut-down.

C. HIGH PRESSURE REFRIGERATION SAFETY

This Chiller has an automatic reset high head pressure switch. The purpose of this switch is to break the 24 volt control circuit in the event of excessive refrigerant pressure cause by clogged or blinded condenser coils, overcharge refrigerant or undersized chiller.

D. INLINE STRAINER

The Inline Strainer is provided to protect the Plate Seal Heat Exchanger from clogging. If the chiller fails to run check strainer for trapped particles. Clean Inline Strainer Screen and restart unit. Note: Pipe dope and thread filings can cause screen to plug prematurely on a new system.

E. LOW PRESSURE FAN CONTROL

This KIG Products Chiller is equipped with a Fan Control. This control is intended to modulate the fan between 300-400 p.s.i. to maintain head pressure. This control is factory set.

F. LOW AMBIENT FAN CONTROL

KIG Products Chiller is equipped with a Low Ambient Thermostat. The thermostat locks out one of the condenser fans to prevent cycling below 60° F ambient.

G. LOW PRESSURE SWITCH

The Chiller has an adjustable low-pressure switch, which is factory set. The low pressure switch will shut down the Chiller in the event of refrigerant loss.

Periodic Preventative Maintenance

- A. Tighten all wire terminals.
- B. Clean and check motor starter and contactor contacts.
- C. Check Condenser fins for dust and dirt.
- D. Clean Condenser filter.
- E. Check glycol/water solution ratio for operating temperature.
- F. Check and clean the water inline strainer.
- G. Check systems for water leaks.
- H. Check refrigerant sight glass for bubbles or foaming.

Warranty

KIG Products wants you to be pleased with the performance of your unit and backs this product with an exceptional parts/service warranty.

WARRANTY PROCEDURE:

1. Be prepared to furnish the following information:
 - A. Complete Model and Serial Number of Unit
 - B. An accurate description of the problem.
2. Call your local KIG Products Distributor.
3. If your distributor is unable to help you then contact KIG Products, Inc.

Replacement Parts – 30 Ton Package Chiller

004138 Strainer, Wye



007455 Motor, 3/4 HP 1075 RPM
460V



005218 Control, Head Pressure
Variable Speed Fan



005184 Switch, High Pressure



007454 Fan, Blade 22"



000251 Thermostat, Remote Bulb



005846 Heat-Exchanger 30 Ton



005214 Switch, Low Pressure



005039 Sensor, Water Temp Probe



003717 Switch, Flow



001298 Contactor, Compressor



005664 Control, Temperature 24V



005068 Contactor, Pump



005814 Compressor, 15 Ton 460V



00253 Switch, On/Off



