

ITEM No.	DRAWING No. PART No.	QTY	MATERIAL	DESCRIPTION
*	*	*	*****	SEE SHEET #3.

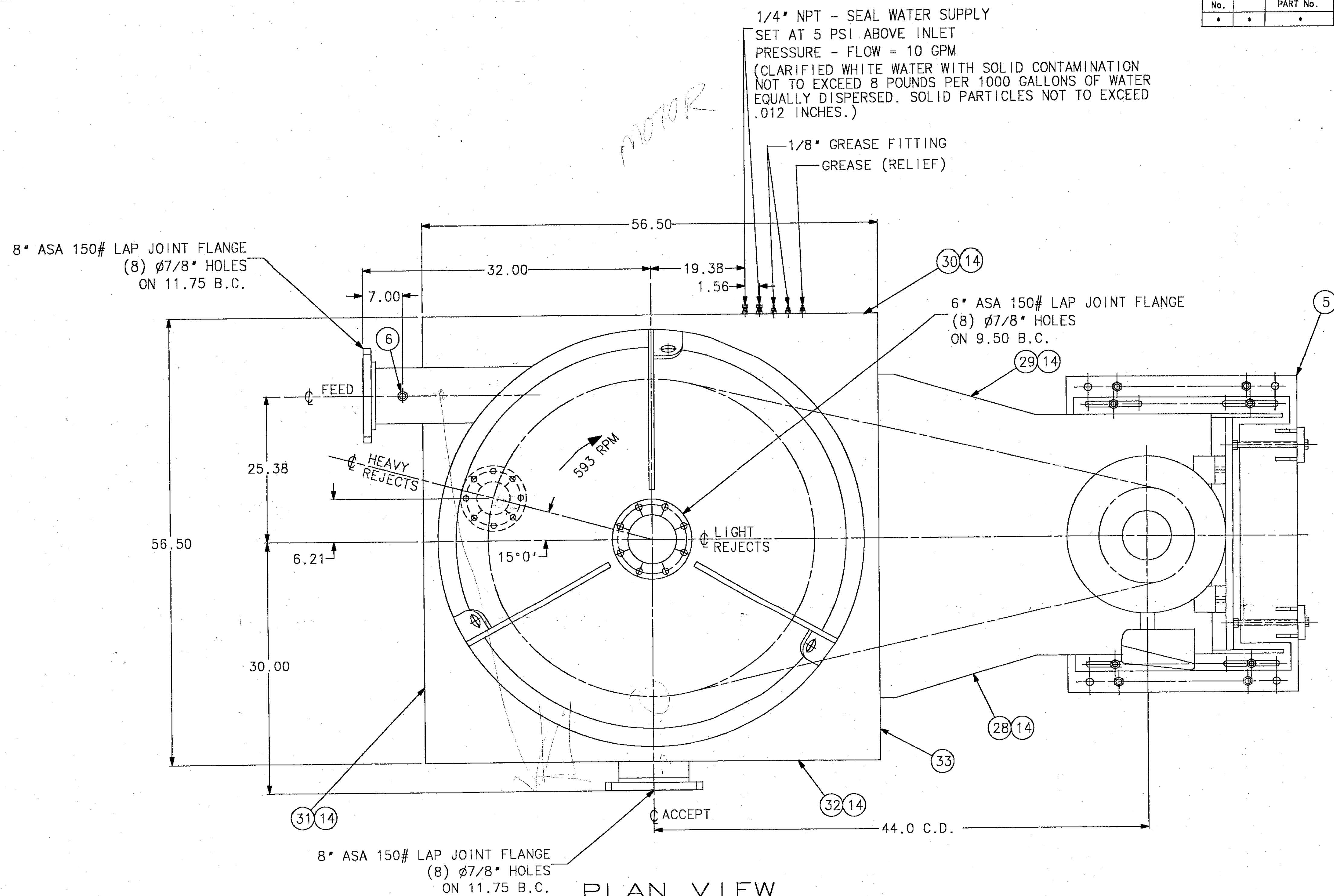

1/4" NPT - SEAL WATER SUPPLY
 SET AT 5 PSI ABOVE INLET
 PRESSURE - FLOW = 10 GPM
 (CLARIFIED WHITE WATER WITH SOLID CONTAMINATION
 NOT TO EXCEED 8 POUNDS PER 1000 GALLONS OF WATER
 EQUALLY DISPERSED. SOLID PARTICLES NOT TO EXCEED
 .012 INCHES.)

PLAN VIEW

THIS DRAWING IS ISSUED
 TO CERTIFY THE DIMENSIONS OF EQUIPMENT
 SUPPLIED BY BLACK CLAWSON

CUSTOMER-US GYPSUM COMPANY
 MILL JACKSONVILLE, FLORIDA
 CUSTOMER ORDER 22522617
 SHARTLE ORDER 4871891
 SERIAL NUMBER 97-FP-0144

THE BLACK CLAWSON CO.
 SHARTLE DIV.
 MIDDLETOWN, OHIO

DATE OF CERTIFICATION 3-24-97

NOTES:

- ① THIS UNIT TO BE HYDROSTATICALLY TESTED BEFORE SHIPMENT TO DETERMINE COMPONENT SEAL EFFECTIVENESS AND WATER TIGHTNESS. TEST PRESSURE TO BE STANDARD WATER MAIN PRESSURE. LEAKS MUST BE CORRECTED BEFORE UNIT IS APPROVED BY QUALITY CONTROL FOR DELIVERY.
- ② ALL PIPE POSITIONS ARE FIXED AS SHOWN
- ③ ALL CONNECTING PIPE FLANGES MUST BE FIELD FITTED IN PLACE BY CUSTOMER.
- ④ DRY WEIGHT: 8400 lbs
 OPERATING WEIGHT: 13900 lbs
 MAX OVERHEAD LIFTING LOAD = 2100 lbs
- ⑤ MAX. HP = 150

NOTES:

- ⑦ DYNAMIC LOAD OF 4350# PER PIER
- ⑧ 8 - 10 PSI PRESSURE DROP
- ⑨ 35 PSI MIN. INLET PRESSURE
 75 PSI MAX. INLET PRESSURE

LOADS	WK ² (#FT ²)
ROTOR, DRIVE, HUB	350
SHEAVES & BELTS	100
TOTAL	450

C.A.D. DRAWING DO NOT UPDATE MANUALLY

DIMENSIONS ARE IN INCHES UNLESS OTHERWISE SPECIFIED
 STANDARD TOLERANCES UNLESS OTHERWISE SPECIFIED

METRIC	UNSI
WHOLE NUMBER .01	ONE PLACE DECIMAL .0004
ONE PLACE DECIMAL .003	TWO PLACE DECIMAL .0005
TWO PLACE DECIMAL .0015	THREE PLACE DECIMAL .0005
ANGULAR .005°	ANGULAR .005°

THESE LIMITS DO NOT APPLY TO ASSEMBLY OR FOUNDATION PLAN DRAWINGS

ORDER No. 4871891	REF DRG No. 4003747	SUPERSEDES	---
SERIAL No. 97-FP-0144	USED ON	SUPERSEDED BY	---
CUSTOMER US GYPSUM	WEIGHT	PATTERN No.	---

This document, including all information contained therein, is the exclusive and confidential property of The Black Clawson Company, and the document and information are not to be copied, reproduced or delivered to others in whole or in part, except with express written permission, and the document is to be returned promptly after having served the purpose for which delivered.

In addition, you agree that the modification of the equipment relating to this print/document without the prior consent of The Black Clawson Company, which causes or contributes to a defect on such equipment shall relieve The Black Clawson Company of its warranty obligations and to the extent that such unauthorized modification contributes directly or indirectly, to an injury to any person or damage property, you hereby agree to indemnify and hold The Black Clawson Company harmless from any liability or claim resulting therefrom.

No.	REVISION	ZONE	DATE	BY	CHKD	APP'D

Black Clawson Company
 SHARTLE DIVISION / STOCK PREP SYSTEMS / PULP MILL PRODUCTS
 MIDDLETOWN, OHIO

TITLE ASSEMBLY - FOR
 MODEL 150-34 FLOAT PURGER

DRAWN M. BROWN DATE 05 FEB 1997 THIRD ANGLE PROJECTION SCALE
 CHECKED DATE 3-24-97
 APPROVED DATE 3-24-97

750 DRG. No. 48718910-2 1 REV SHEET 2 OF 3