

复合袋制袋机系列

Laminated Pouch Bag Making Machine Series

Add: No.518 Yuanhang Road, Gexiang New Area,
Nanbin Street, Ruian City, Zhejiang Province, China.

Phone / Whatsapp: 86-13958813143

E-mail: cwding@zjchuangwei.com

Web: www.chovyting.com

chovyting.en.alibaba.com

www.chaowei-machine.com

chuangweijx.1688.com



扫一扫
访问官方网站

www.chovyting.com

2024

ABOUT US

制袋机行业竞争力品牌
The competitive Brand of Bag Making Machine Industry

Since 1999

CHOVYTING Machinery is a manufacturer specialized in the design and production of plastic bag machinery. Since the company entered the new factory in 2017, it has adopted modern management methods such as 6S site management, PMC production management and international standard QC management, and adopted 3D mechanical design and IEC standard electrical 3D design to standardize production operations, so that to receive a higher rating from customer after use. In terms of production technology, CHOVYTING continuously purchases the world's top CNC large-scale machining centers to make parts processing more precise and standardized, and combines a strong R & D team and continuous innovation to develop various professional machinery to provide customers with complete technology and thoughtful service. CHOVYTING always insists on providing customers with high quality and perfect products. Therefore, the actual process of each production step is strictly controlled, and the ISO-9000 quality system process is used to track and control and have passed the EU CE safety regulations. Today, CHOVYTING is the largest manufacturer of bag making machines in China, and has long-term strategic cooperation with senior engineers from Germany, Italy, Spain, the United States and Taiwan to absorb the latest and most comprehensive mechatronics technology.

超伟机械是专业于设计、生产塑胶袋机械的制造商，自 2017 年超伟公司入驻新厂区后，采用 6S 现场管理、PMC 生产管理和国际标准的 QC 管理等现代化管理方式，并采取 3D 机械设计和 IEC 标准电气 3D 设计使生产作业标准化，使产品品质在顾客使用后获得了更高评价。在生产技术方面，超伟不断购置国际顶尖的 CNC 大型加工中心，使零件加工更精密和更标准化，并结合强大的研发团队和持续不断的创新，开发各种专业机械，为顾客提供完整的技术和周全的服务。超伟始终坚持提供顾客高品质和完美的产品，因此所有员工的实际制程亦受到严格的控制，并采用 ISO-9000 质量体系流程全程追踪控制，并通过欧盟 CE 安全规范。

如今超伟在中国已经是大型的制袋机制造商，并且与德国、意大利、西班牙、美国及台湾等国家和地区的资深工程师长期战略合作，提供最新、最全面的机电一体化技术。超伟以瑰丽的未来放眼于世界各地，并期望以更新的技术面对未来的挑战。



Connotation

超伟内涵

C H O V Y T I N G

Customer Help Open Veneration Young Team Idea Noble Glory
客户 帮助 开放 尊敬 年轻 团队 创新 高尚 荣誉



Quality

ORIGINAL CHOVYTING
GUARANTEED QUALITY
超伟原装 品质保障



超伟在所有方面都拥有卓越的表现：卓越的工程，产品，服务和创新。卓越的运营源自我们不断改善的心态和我们将企业打造为市场第一的方式。

CHOVYTING excels in all aspects: Superior engineering, products, services as well as innovation. Excellent operation comes from our mindset of continuous improvement and the way we build our business to be No. 1 in the field.

无论是品质或服务
超伟在顾客群中同样获得极高评价

CHOVYTING has received a very high evaluation from customers regardless of quality or service

在生产技术方面，超伟以顶尖的研发能力和持续不断的创新，开发各种专业机械。

In terms of production technology, CHOVYTING develops various professional machinery with top research and development capabilities and continuous innovation.

我们努力成为客户工艺技术顾问、客户的设备专家。积极为客户盈利而完善服务体系，为客户做到最好！

We are working hard on being the best professional solution provider, technical consultant, and most efficient and profitable solution of paper bag machine supplier.



- 
员工敬业度
与领导力
- 
结果导向
- 
业务规划
- 
流程管理
- 
客户至上
- 
持续改进

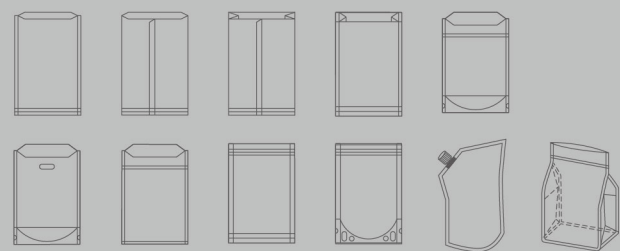

Heavy Duty Multifunction Laminated Pouch Bag Making Machine Series

多功能食品包装袋制袋机系列

CWZD-600C 重型复合袋多功能制袋机

Heavy Duty Multifunction Laminated Bag Making Machine

optional 选购

- * unwind storage (non-stop roll exchange) 放料储料 (不停机换卷)
- * special die cut machine(模切机)
- * main motor servo 主机伺服
- * double cutting system and round corner puncher (双切刀和圆角冲)



四线密封
4 Lane Seal

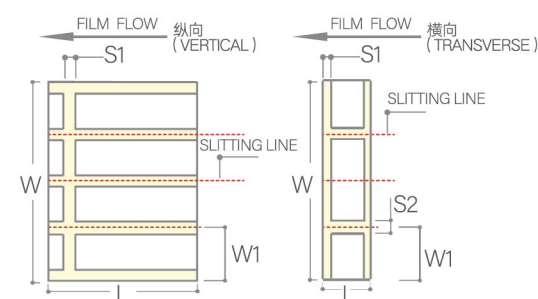

拉链三边封
Zipper Seal With Three Sides

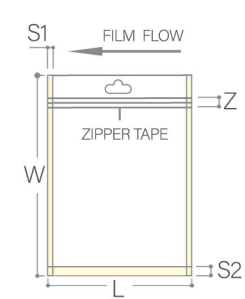

单 / 双线站立拉链三边封
2 Lane Stand Pouch With Zipper

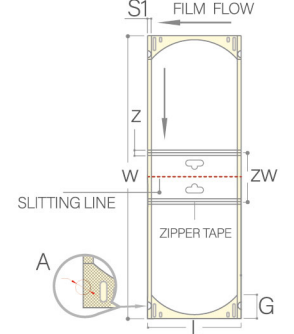

L (送袋长度 Bag Making Length)	50-420mmX 6N (N=SKIP)	Unwinder Rolls Film Width (放卷宽度)	1200mm
W (制袋宽度 Bag Making Width)	100-580mm	Unwinder Diameter Of Roll (放卷直径)	Φ800mm
W1(单线宽度 Single Lane Width)	75-580mm	Speed Of Bag Making (制袋速度)	
S1(底封宽度 Bottom Seal Width)	5-60mm	*3 Side Sealing Bag (三边封)	170pcs/min
S2 (纵封宽度 Vertical Seal Width)	10-60mm	*Zipper Bag (三边封拉链袋)	150pcs/min
Z (拉链宽度 Zipper Width)	13mm	*Stand Up And Zipper Bag (站立拉链袋)	150pcs/min
ZW (两线拉链中心距 Double Line Zipper Bag Central Distance)	60mm	*Line Speed (线速度)	40m/min
A (冲孔直径 Punch Diameter)	Φ16mm	Dimension Of Machine L*W*H (机器尺寸)	14.5*2.2*2m
G (插底深度 Bottom Gusset Depth)	25-60mm	Air Compressor (气压)	0.6mpa (6kgf/cm ²)
		Water Colling (冷却水)	About 15L/min

*袋高超过420mm时, 使用倍送功能, 倍送: N≤6
When the bag height is more than 420mm, please use skip function, skip: N≤6
*制袋能力会受薄膜材质、袋子规格、操作经验等状况影响, 以实际制袋速度为准。
*The bag making ability will be affected by the film material, bag specification, operating experience and other conditions, and the actual bag making speed shall prevail.

*由于不断改善及研发新功能, 机器外观、性能特点及技术参数如有更改, 恕不另行通知。
*Because of the non-stop improving of machine and development of new functions, appearance and specification is subject to change without notice.

CW-600C+CS 全自动复合袋多功能制袋机

Fully Automatic Multifunction Laminated Bag Making Machine

optional 选购

- * unwind storage (non-stop roll Exchange) 放料储料 (不停机换卷)
- * special die cut machine(模切机)
- * main motor servo 主机伺服
- * double cutting system and round corner puncher (双切刀和圆角冲)

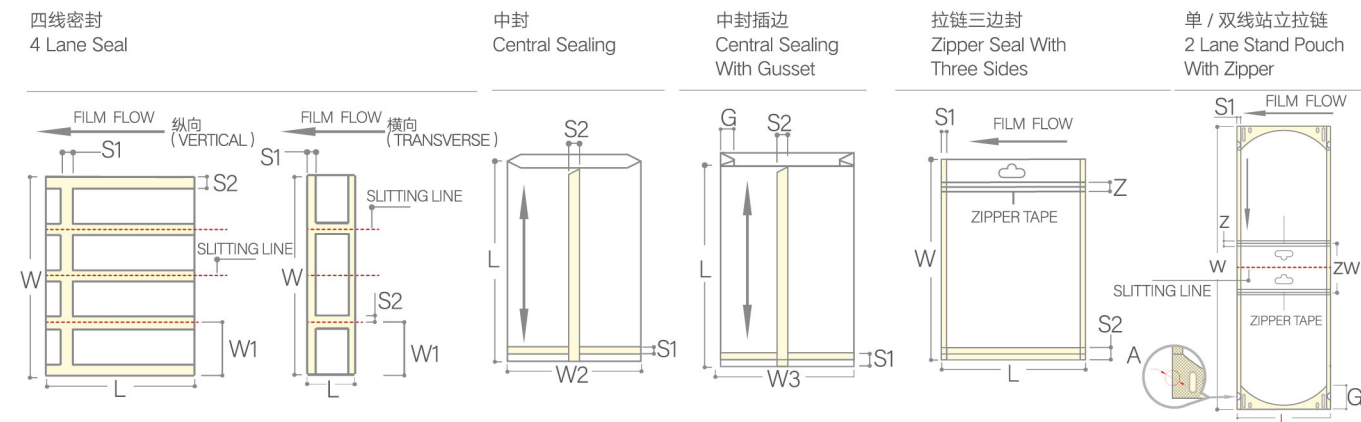
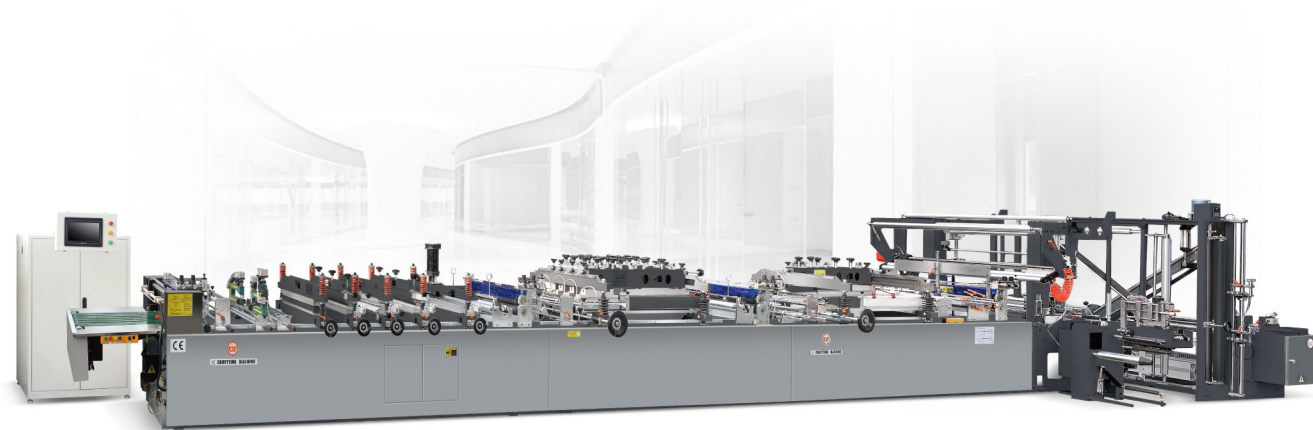

L (送袋长度 Bag Making Length)	50mm-420mm X 6N (N=SKIP)	Unwinder Rolls Film Width (放卷宽度)	1200mm
W (制袋宽度 Bag Making Width)	100mm-580mm	Unwinder Diameter Of Rolls (放卷直径)	Φ800mm
W1(单线宽度 Single Line Width)	75-580mm	Speed Of Bag Making (制袋速度)	
W2 (中封宽度 Center Width)	100-400mm	*3 Side Sealing Bag (三边封)	170pcs/min
W3 (中封插边宽度 Center Gusset Seal Width)	W2-2G	*Center Sealing Bag (中封袋)	150pcs/min
S1 (底封宽度 Bottom Seal Width)	5mm-60mm	*Center Sealing With Gusset (中封插边)	140pcs/min
S2 (纵封宽度 Vertical Seal Width)	10mm-60mm	*Zipper Bag (三边封拉链)	150pcs/min
Z (拉链宽度 Zipper Width)	13mm	*Stand Up With Zipper (站立拉链)	150pcs/min
ZW (两线拉链中心距 Double Line Zipper Bag Central Distance)	60mm	*Line Speed (线速度)	40m/min
A (冲孔直径 Punch Diameter)	Φ16mm	Dimension Of Machine L*W*H (机器尺寸)	16*2.2*2m
G (插底深度 Bottom Gusset Depth)	25mm-60mm		

*袋高超过420mm时，使用倍送功能，倍送：N≤6
When the bag height is more than 420mm, please use skip function, skip: N≤6
*制袋能力会受薄膜材质、袋子规格、操作经验等状况影响，以实际制袋速度为准。
*The bag making ability will be affected by the film material, bag specification, operating experience and other conditions, and the actual bag making speed shall prevail.

*由于不断改善及研发新功能，机器外观、性能特点及技术参数如有更改，恕不另行通知。
*Because of the non-stop improving of machine and development of new functions, appearance and specification is subject to change without notice.

CW-600C+FD 重型复合袋多功能复合袋+单片膜插底制袋机

Heavy Duty Multi-Function Laminated Bag Making Machine + Single Sheet Film Doypack Bag

optional 选购

- * unwind storage (non-stop roll exchange) 放料储料 (不停机换卷)
- * special die cut machine(模切机)
- * main motor servo 主机伺服
- * double cutting system and round corner puncher (双切刀和圆角冲)

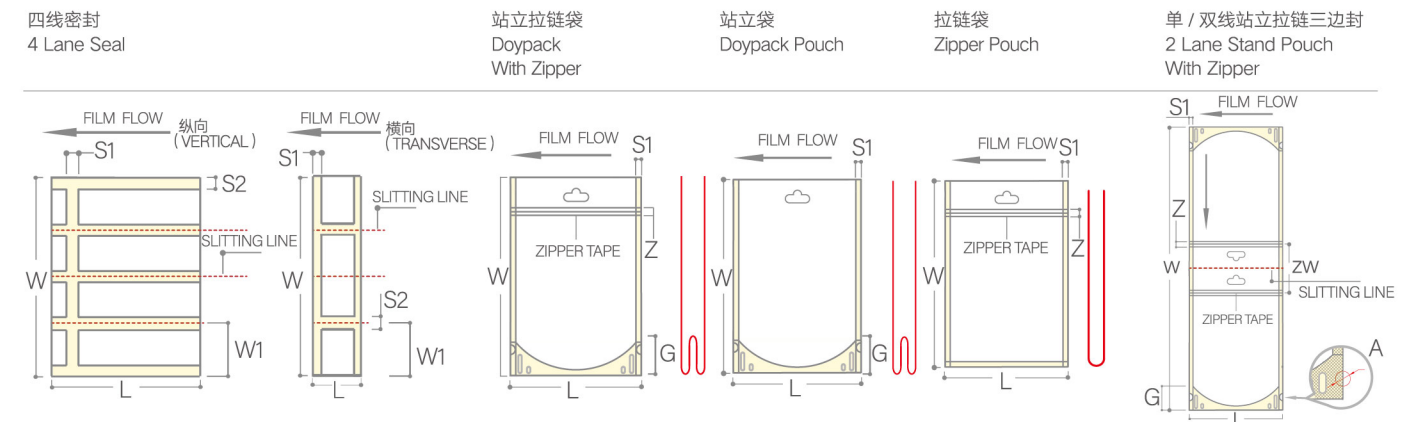
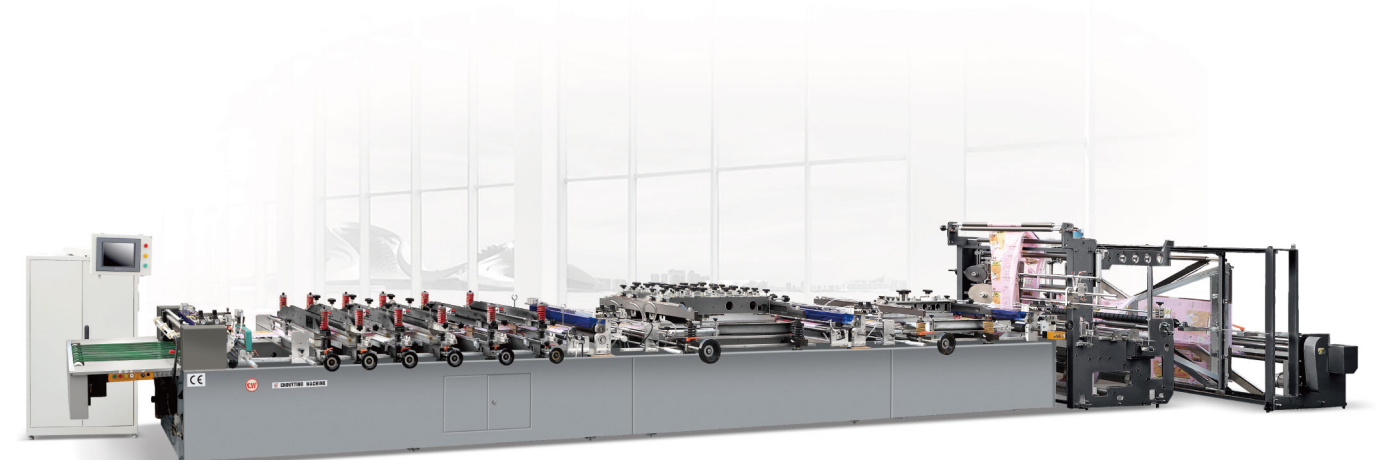

L (送袋长度 Bag Making Length)	50mm-420mm X 6N (N=Skip)	Unwinder Rolls Film Width (放卷宽度)	1200mm
W (制袋宽度 Bag Making Width)	100mm-580mm	Unwinder Diameter Of Roll (放卷直径)	Φ800mm
W1(单线宽度 Single Line Width)	75-580mm	Speed Of Bag Making(制袋速度)	
S1(底封宽度 Bottom Seal Width)	5mm-60mm	*3 Side Sealing Bag(三边封)	170pcs/min
S2 (纵封宽度 Vertical Seal Width)	10mm-60mm	*Zipper Bag(三边封拉链袋)	150pcs/min
Z (拉链宽度 Zipper Width)	13mm	*Stand Up And Zipper Bag (第三张站立拉链袋)	150pcs/min
ZW (两线拉链中心距 Double Line Zipper Bag Central Distance)	60mm	*Doypack And Zipper Bag (单张站立拉链袋)	150pcs/min
G (插边深度 Edge Gusset Depth)	25mm-60mm	*Line Speed (线速度)	40m/min
A (冲孔直径 Punch Diameter)	Φ16mm	Dimension Of Machine L*W*H(机器尺寸)	17*1.9*2.4m (无储料)

*袋高超过420mm时，使用倍送功能，倍送：N≤6
When the bag height is more than 420mm, please use skip function, skip: N≤6
*制袋能力会受薄膜材质、袋子规格、操作经验等状况影响，以实际制袋速度为准。
*The bag making ability will be affected by the film material, bag specification, operating experience and other conditions, and the actual bag making speed shall prevail.

*由于不断改善及研发新功能，机器外观、性能特点及技术参数如有更改，恕不另行通知。
*Because of the non-stop improving of machine and development of new functions, appearance and specification is subject to change without notice.

CW-600ZF+SZ 高速中底封袋专用制袋机

High Speed Bag Making Machine Specially for Central & Bottom Sealing Bag

optional 选购

- * special die cut machine(模切机)
- * main motor servo 主机伺服
- * double cutting system and round corner puncher (双切刀和圆角冲)

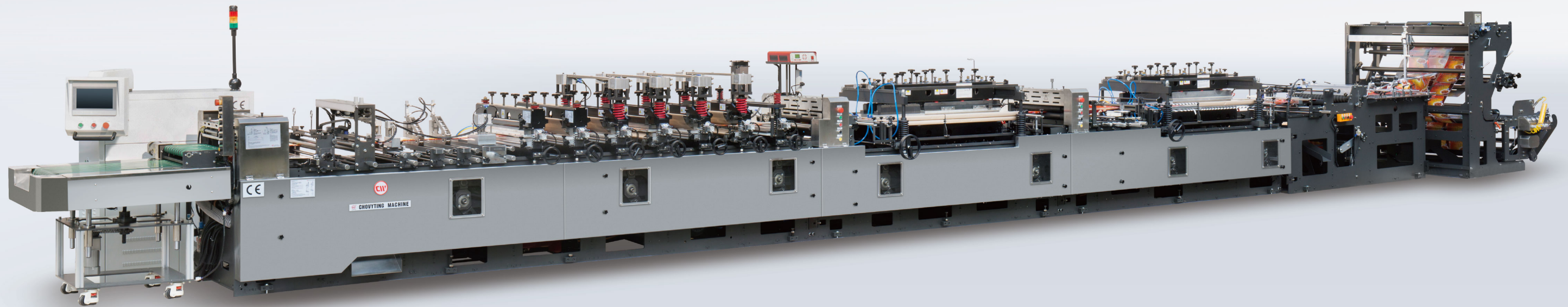

- | | | | | | | | | |
|--------------------|------------------------------|----------------------|-----------------------------------|-------------------------------|-------------------------|------------------------------|----------------------|---------------------|
| 两边封
2 Side Seal | C 折两边封
C Fold 2 Side Seal | 普通中封
Central Seal | 中封带插边
Central Seal With Gusset | 边封插边
Side Seal With Gusset | 四边封袋
Four Sides Seal | 站立拉链袋
Doypack With Zipper | 站立袋
Doypack Pouch | 拉链袋
Zipper Pouch |
|--------------------|------------------------------|----------------------|-----------------------------------|-------------------------------|-------------------------|------------------------------|----------------------|---------------------|

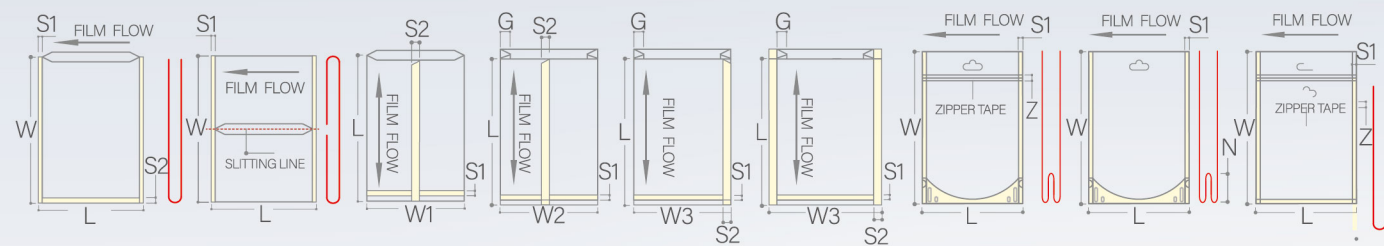

L (送袋长度 Bag Making Length)	50-420mm x 6n (N=Skip)	Unwinder Rolls Film Width (放卷宽度)	1200mm
W (制袋宽度 Bag Making Width)	100-580mm	Unwinder Diameter Of Rolls (放卷直径)	Φ800mm
W1 (中封宽度 Center Width)	100-300 (单边翻膜有限 Single Side Turning Is Limited)	Speed Of Bag Making (制袋速度)	
W2 (后面插边 unwinder gusset)	100-580m	*2 Sides Seal (两边封)	140pcs/min
W2 (中间插边 middle gusset)	580mm-2G	*C Fold 2 Sides Seal (C 折两边封)	170pcs/min
W3 (后面插边 unwinder gusset)	100-400m	*Central Seal (普通中封)	170pcs/min
S1 (底封宽度 Bottom Seal Width)	5-60mm	*Central Seal With Gusset (中封带插边)	160pcs/min
S2 (纵封宽度 Vertical Seal Width)	10-20mm	*Side Seal With Gusset (边封插边)	120pcs/min
Z (拉链宽度 Zipper Width)	13mm	*Four Sides Seal (四边封)	120pcs/min
G (插边深度 Edge Gusset Depth)	25-60mm	*Doypack With Zipper (站立拉链)	120pcs/min
		*Doypack Pouch / Zipper Pouch (站立袋 / 拉链袋)	120pcs/min
		Dimension Of Machine L*W*H (机器尺寸)	16.5*1.9*1.8m (无储料)

*袋高超过420mm时，使用倍送功能，倍送：N≤6
When the bag height is more than 420mm, please use skip function, skip: N≤6
*制袋能力会受薄膜材质、袋子规格、操作经验等状况影响，以实际制袋速度为准。
*The bag making ability will be affected by the film material, bag specification, operating experience and other conditions, and the actual bag making speed shall prevail.

*由于不断改善及研发新功能，机器外观、性能特点及技术参数如有更改，恕不另行通知。
*Because of the non-stop improving of machine and development of new functions, appearance and specification is subject to change without notice.

CW-700SQB 复合膜方底袋制袋机

Heavy Duty Multi-Function Laminated Flat-Bottom Pouch Making Machine



- 普通方底袋
Flat Bottom
Box Pouch
- 普通方底袋 1 出 2
Two Lane Flat
Bottom Box Pouch
- 方底拉链袋
Flat Bottom Box
Pouch With Zipper
- 方底拉链袋 1 出 2
Two Lane Flat Bottom
Box Pouch With Zipper
- 四边封袋
Pinch Bottom /
4 Side Seal Bag
- 四边封拉链袋
Pinch Bottom +
Zipper / 4 Side Seal
Bag+zipper
- 四边封袋底部打孔
Pinch Bottom With Bottom
Holes/ 4 Side Seal Bag With
Bottom Holes

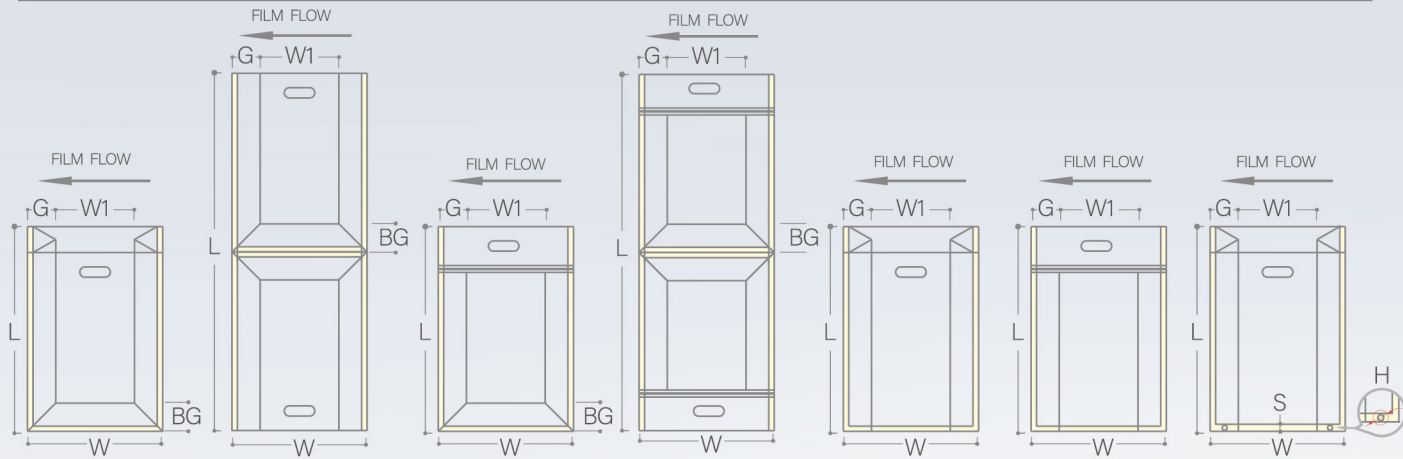

L (袋子高度 Bag Making Height)	150-650mm-2BG (*1)	Unwinder Of Body Material (主料放卷宽度)	1300mm
*1 主料单张膜宽	From Single Web Film	Unwinder Of Gusset Material (风琴膜宽)	400mm
L (袋子高度 Bag Making Height)	150-650mm (*2)	Unwinder Diameter Of Body Material (主料放卷直径)	Φ800mm
*2 底部副料膜宽	Additional Film Froms Flat bottom	Unwinder Diameter Of Gusset Material (风琴膜直径)	Φ800mm
W (制袋宽度 Bag Making Width)	Max: 100-420mm	Speed Of Bag Making (制袋速度)	150pcs/min
W1 (单线宽度 Single Line Width)	Min: 15mm	Line Speed (线速度)	30m/min
G (风琴膜深度 Side gusset depth)	30-90mm	Machine Weight (机器重量)	约 13200kg
BG (底膜深度 Bottom gusset depth)	30-90mm	Dimension Of Machine L*W*H (机器尺寸)	25.6*5.5*2.1m
H (底部冲孔直径 Bottom Punch)	Φ16mm		
S (底部封线 Bottom Seal)	5-60mm		

*制袋能力会受薄膜材质、袋子规格、操作经验等状况影响，以实际制袋速度为准。

*The bag making ability will be affected by the film material, bag specification, operating experience and other conditions, and the actual bag making speed shall prevail.

*由于不断改善及研发新功能，机器外观、性能特点及技术参数如有更改，恕不另行通知。

*Because of the non-stop improving of machine and development of new functions, appearance and specification is subject to change without notice.

CW-400MCP 迷你型中封制袋机

Mini Center Sealing Pouch Machine

CWZD-600A 三边封(中封)多功能制袋机

Three Side & Central Sealing Pouch Making Machine

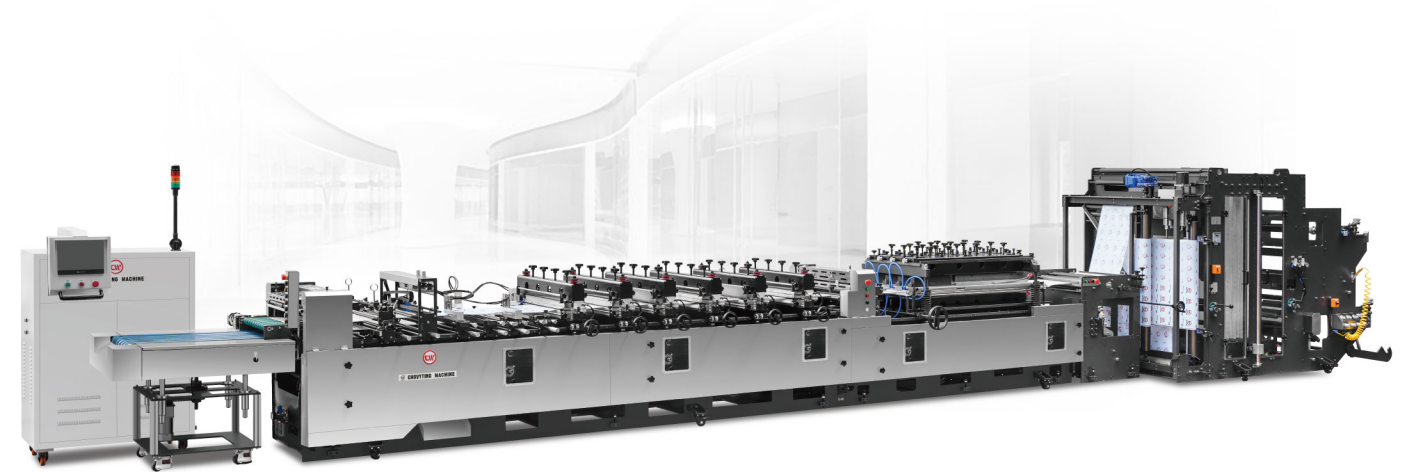
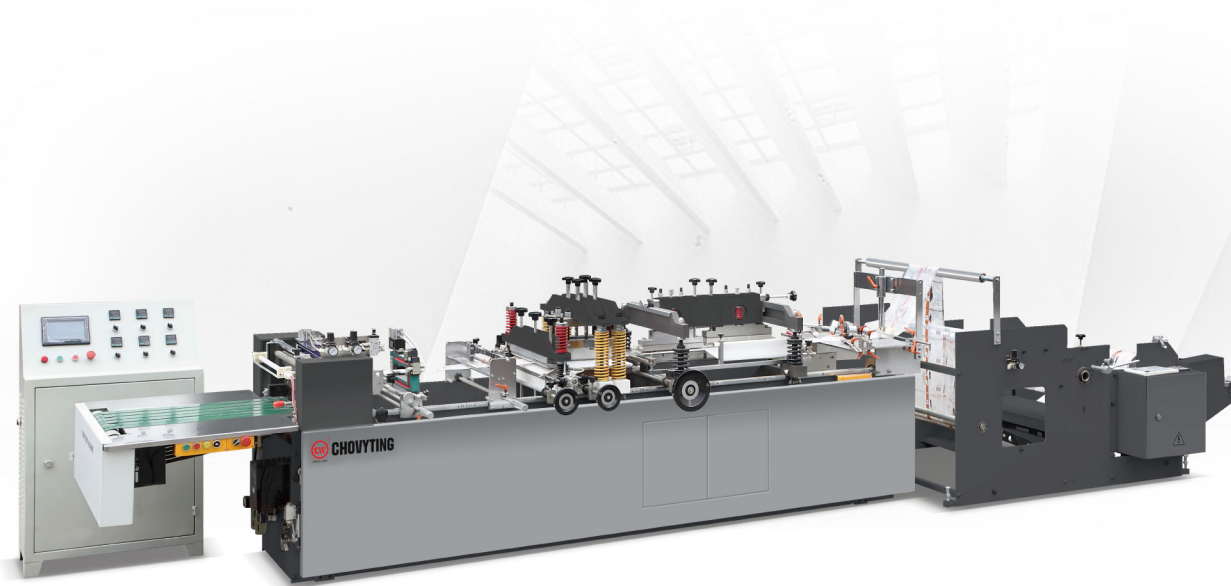

中封
Central Seal Pouch

中封插边
Central Seal With Gusset

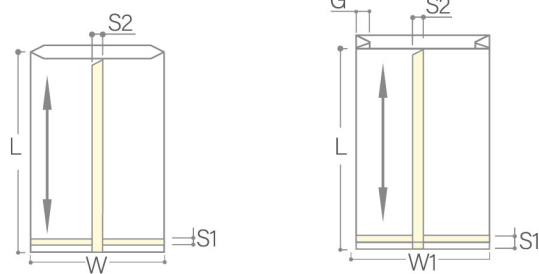

L (制袋长度 Bag Making Length)	50-300mm	Unwinder Rolls Film Width (放卷宽度)	800mm
W (制袋宽度 Bag Making Width)	100-350mm	Unwinder Diameter Of Rolls (放卷直径)	Φ800mm
W1 (制袋宽度 Bag Making Width)	W-2G	Dimension Of Machine L*W*H (机器尺寸)	6.5*1.6*1.7m
G (中封插边 Center Gusset Seal)	25-60mm		
S1=S2 (封线宽度 Seal Line Width)	10-60mm		

*制袋能力会受薄膜材质、袋子规格、操作经验等状况影响，以实际制袋速度为准。
 *The bag making ability will be affected by the film material, bag specification, operating experience and other conditions, and the actual bag making speed shall prevail.
 *由于不断改善及研发新功能，机器外观、性能特点及技术参数如有更改，恕不另行通知。
 *Because of the non-stop improving of machine and development of new functions, appearance and specification is subject to change without notice.

四线密封
4 Lane Bottom Seal

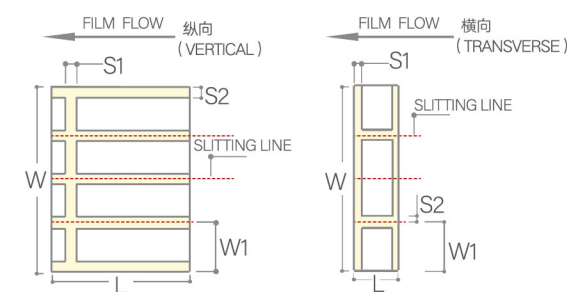

L (送袋长度 Bag Making Length)	50-420mm × N (倍送 Skip: n≤6)	Unwinder Rolls Film Width (放卷宽度)	1200mm
W (制袋宽度 Bag Making Width)	100-580mm	Unwinder Diameter Of Roll (放卷直径)	Φ800mm
W1 (单线宽度 Single Line Width)	75-580mm	Speed Of Bag Making (制袋速度)	
S1 (底封宽度 Bottom Seal Width)	5-60mm	*3 Side Sealing Bag (三边封)	170pcs/min
S2 (纵封宽度 Vertical Seal Width)	10-60mm	*Line Speed (线速度)	40m/min
Air Compressor (气压)	0.6mpa (6kgf/cm ²)	Dimension Of Machine L*W*H (机器尺寸)	11.8*1.9*1.96m
Water Colling (冷却水)	About 15L/min		(带储料 With Storage Function)

*袋高超过420mm时，使用倍送功能，倍送：N≤6
 When the bag height is more than 420mm, please use skip function, skip: N≤6
 *制袋能力会受薄膜材质、袋子规格、操作经验等状况影响，以实际制袋速度为准。
 *The bag making ability will be affected by the film material, bag specification, operating experience and other conditions, and the actual bag making speed shall prevail.
 *由于不断改善及研发新功能，机器外观、性能特点及技术参数如有更改，恕不另行通知。
 *Because of the non-stop improving of machine and development of new functions, appearance and specification is subject to change without notice.

optional 选购

- * unwind storage (non-stop roll exchange) 放料储料 (不停机换卷)
- * special die cut machine (模切机)
- * main motor servo 主机伺服
- * double cutting system and round corner puncher(双切刀和圆角冲)
- * center sealing gusset bag 中封插边袋 (参数参考 CWZD-600C+CS)