

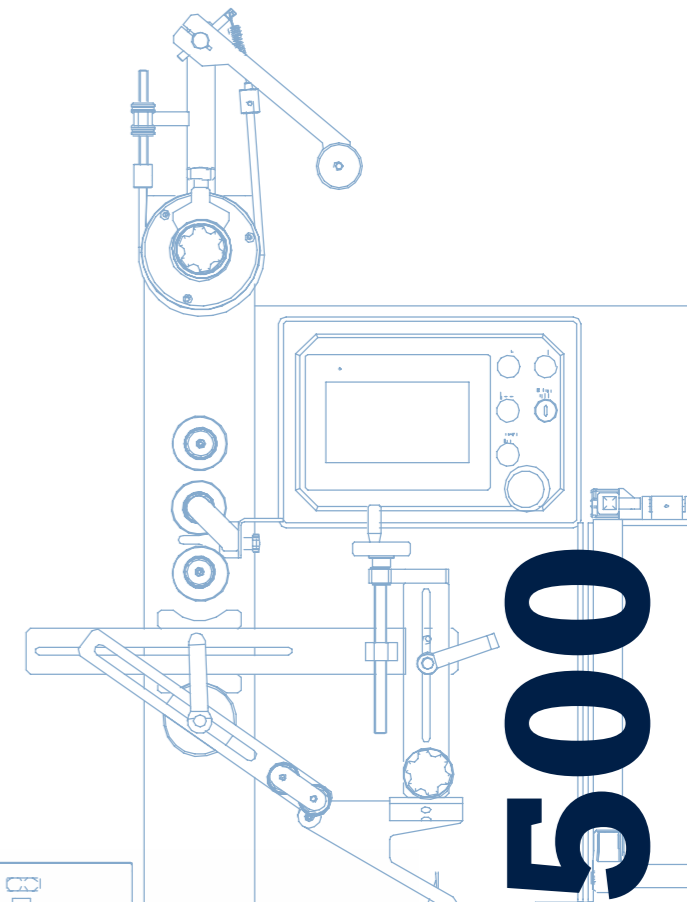

Horizontal
flow pack

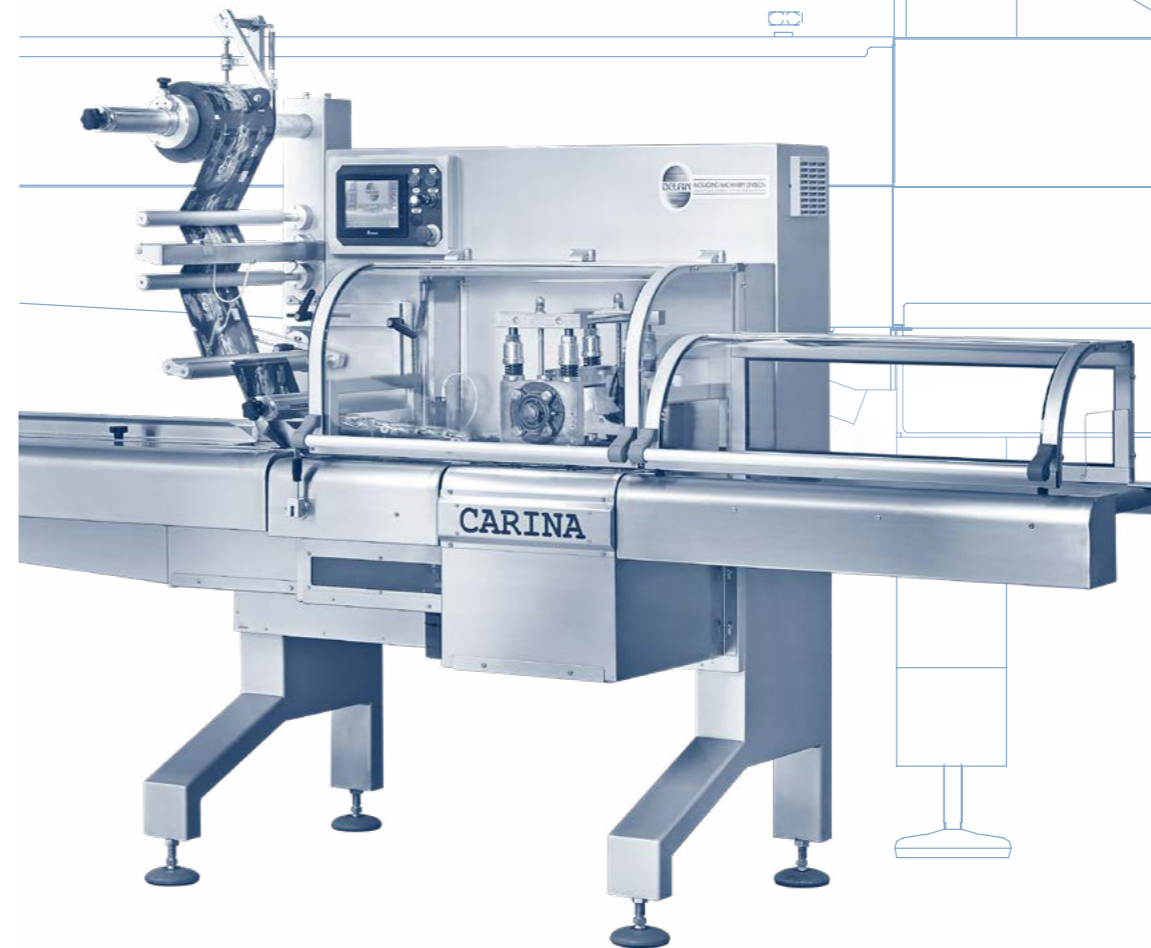

CARINA 500

MADE IN ITALY

The information contained in this brochure is purely indicative and we therefore reserve the right to change without notice



Delfin srl
Via G. Keplero, 18
36034 Malo, VI - Italy

+39 0445 58 06 88
info@delfin.it
www.delfin.it



Flow pack CARINA 500

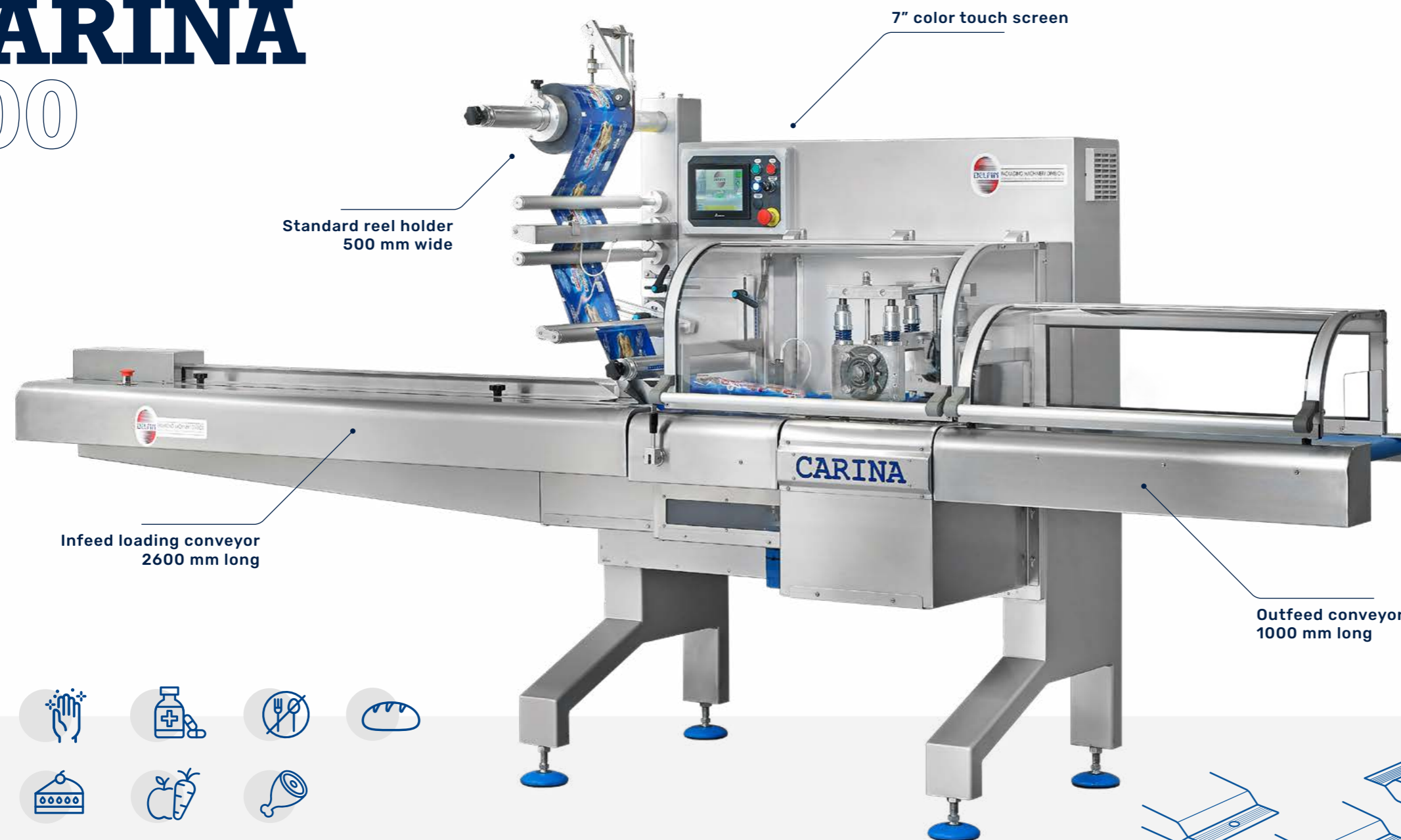

Standard reel holder
500 mm wide

7" color touch screen

Infeed loading conveyor
2600 mm long

Outfeed conveyor
1000 mm long

- RAL 9006 grey painted steel frame with AISI 304 stainless steel guards;
- Longitudinal sealing unit consisting of three pairs of wheels: pulling, sealing and flap folding. Pneumatic opening of welding wheels;
- Rotary transversal sealing unit with one or multiple 240 mm wide up jaws;
- One self-centring reel holder;
- Adjustable or fixed forming box;
- Photocell for printed film;
- Photocell for "No Product - No Bag";
- Standard spare parts kit;
- Safety guards in transparent shockproof plastic material.



← Type of packaging

Products length	min 50 mm	max 600 mm
Product width	min 10 mm	max 220 mm
Product height	min 1 mm	max 120 mm
Reel holder width	max 500 mm on demand 550 mm	
Mechanical speed	max 200	
Weight	610 kg	
Power supply	4 Kw	

- Motorization by means of 3 independent Brushless motors
- Mechanical speed 200 rpm
- Voltage 400V / 3 phase Earth + Neutral, 50Hz
- Machine conforms to CE regulations

