

User Manual

Water mixing and dosing system

(WAMI)

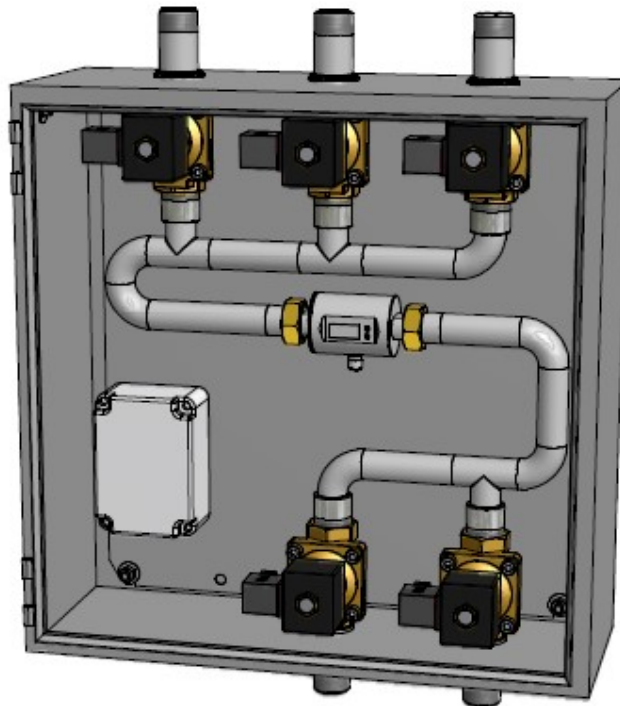

W&K-Automation GmbH

Vogelsanger Str. 356-358

50827 Köln

Tel.: 0221-912829-0

Fax.: 0221-912829-30

E-Mail: info@wuk-automation.de

Table of Contents

TABLE OF CONTENTS	2
1 INTRODUCTION	5
2 BASIC OPERATIONS.....	6
3 MAIN IMAGE	7
3.1 FUNCTIONS	7
3.2 DESCRIPTION OF INDIVIDUAL PANELS	7
4 SETTINGS	10
4.1 FUNCTIONS	11
4.2 DESCRIPTION OF INDIVIDUAL PANELS	11
5 TEMPERATURE SETTINGS	12
5.1 FUNCTIONS	12
5.2 DESCRIPTION OF INDIVIDUAL PANELS	12
6 TEMPERATURE TREND.....	15
6.1 FUNCTIONS	15
6.2 DESCRIPTION OF INDIVIDUAL PANELS	15
7 TEMPERATURE SWITCHING POINTS	16
7.1 FUNCTIONS	16
7.2 DESCRIPTION OF INDIVIDUAL PANELS	17
7.3 LIMITATIONS CITYWATER/EISWATER/MAX-TEMPERATURE	17
8 PRE RUN / ICE WATER PRE RUN	20
8.1 FUNCTIONS	20
8.2 DESCRIPTION OF INDIVIDUAL PANELS	21

9	PRE RUN HOT WATER.....	22
9.1	FUNCTIONS	22
9.2	DESCRIPTION OF INDIVIDUAL PANELS	23
10	POST RUN	24
10.1	FUNCTIONS	24
10.2	DESCRIPTION OF INDIVIDUAL PANELS	25
11	COUNTER.....	26
11.1	FUNCTIONS	26
11.2	EXPLANATION OF THE INDIVIDUAL PANELS.....	27
12	PRE SWITCH VALUES.....	28
12.1	DESCRIPTION OF INDIVIDUAL PANELS	28
13	VALVES	30
13.1	FUNCTIONS	30
13.2	DESCRIPTION OF INDIVIDUAL PANELS	30
13.3	CYCLING SMALL AMOUNTS	32
14	SYSTEM IMAGES.....	34
14.1	DESCRIPTION OF INDIVIDUAL PANELS	34
15	"MISCELLANEOUS" MENU.....	36
15.1	FUNCTIONS	36
15.2	DESCRIPTION OF INDIVIDUAL PANELS	38
15.3	"MISCELLANEOUS 2" MENU	39
15.4	"PROFIBUS" MENU	40
16	MANUAL OPERATION.....	42
16.1	FUNCTIONS	42
16.2	DESCRIPTION OF INDIVIDUAL PANELS	42
17	ERROR MESSAGES.....	43
18	INSTALLATION INSTRUCTIONS.....	44



18.1	WATER CONNECTIONS OF WAMI TYPE III	44
18.2	WATER CONNECTIONS OF WAMI TYPE IV	46
19	LIST OF FIGURES	48



1 Introduction

Should you have any questions on the operation of the system or possibly want extensions to your system, please contact our office.

Also we offer a fast, spare parts service hotline.

2 Basic Operations

The operating display is a HMI device with functions keys touch panel. In some images the functions keys are assigned special functions. These functions are presented in the description. Setpoints are entered via an on-screen numeric keypad on the touch screen.

General Information

 Press the button

 Please Note

 Caution

3 Main Image

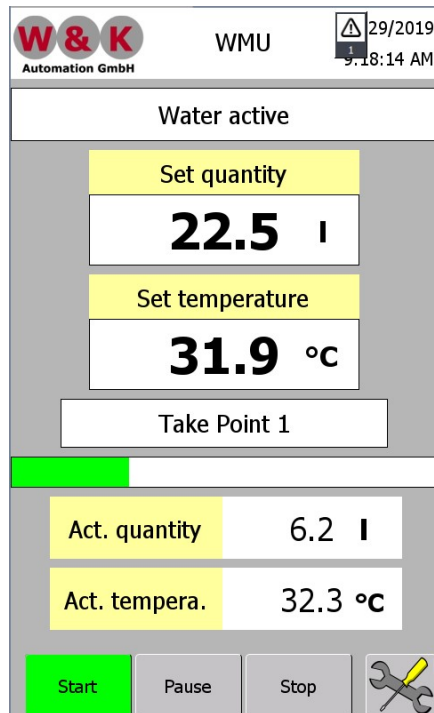

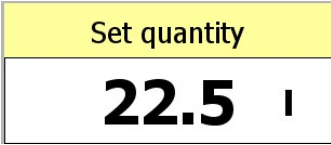



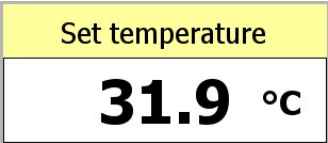



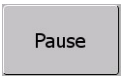













Figure 1 Main Screen









3.1 Functions

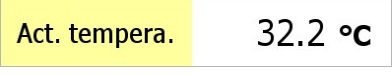
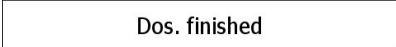

If the WAMI restarted appears after a few seconds of this main image. Repeatedly click the back button,  or by pressing the main button image  in the lower-level images you can always return to the main display.

3.2 Description of Individual Panels

<i>Button/Indicator</i>	<i>Action</i>	<i>Remark</i>
	 By the touch panel	Press the desired quantity into the numeric input window (see below). With this input field, enter the desired quantity to be dosed.

<i>Button/Indicator</i>	<i>Action</i>	<i>Remark</i>
	 By the touch panel	Press the set temperature into the numeric input window opens (see below). With this input field the desired temperature of dosing can be applied.
	 Pressing the start button	By pressing the Start button the dosage begins.
	 Pressing the pause button	By pressing the Pause button the dosage is paused. To end the pause press the start button.
	 Pressing the stop button	By pressing the Stop button the dosage is stopped.
	 Pressing the settings button	Press this button to display the set-up menu. Once entered a Username and Password is requested Username: ADMIN Password: 1280
	 Pressing the F1 Key	With this button you can start a dosage.
	 Pressing the F2 Key	With this button you can stop an overdose.
	 Pressing the F3 Key	With this button you can decrease the set temperature. The longer you hold the button the faster the temperature change.
	 Pressing the F4 Key	With this button you can increase the set temperature. The longer you hold the button the faster the temperature change

<i>Button/Indicator</i>	<i>Action</i>	<i>Remark</i>
	 Pressing the F5 Key	With this button you can decrease the target amount. The longer you hold the button the faster the target amount changes.
	 Pressing the F6 Key	With this button you can increase the target amount. The longer you hold the button the faster the target amount changes.
	Display	The current actual quantity is displayed here.
	Display	The current actual temperature is displayed here.
 (Top of the image)	Status bar	The following status messages can be seen here:- <ul style="list-style-type: none"> - Water active - Water break - Post run active - Pre run active - Dos. finished - Dos. Stopped - Search active - Ice water prerun active - Hot water prerun active
 (Centre of the Image)	 Close tapping point selection	If multiple sampling agencies (ES) are present, then the field ES can be selected. If only one ES is present, then it must be selected "extraction point 1".
 (Bottom of the Image)	Progress bar	If dosing is active then a progress bar appears.

<i>Button/Indicator</i>	<i>Action</i>	<i>Remark</i>
	<p>☞ Numeric Input Field</p>	<p>Each entry must be completed with the entry key.</p> <div style="border: 1px solid gray; padding: 5px; width: fit-content; margin: 10px auto;">  </div>

4 Settings

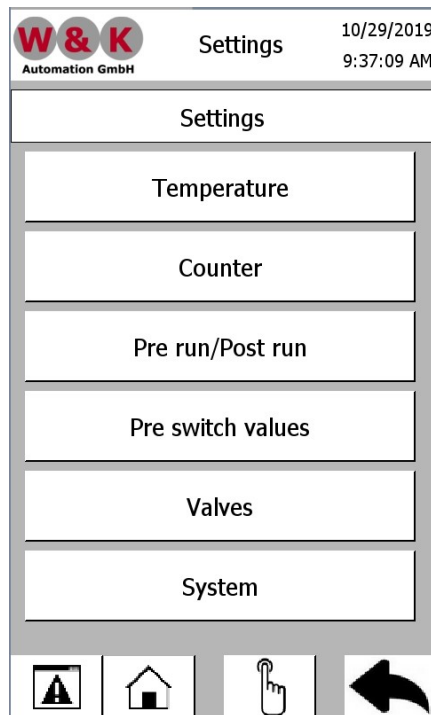
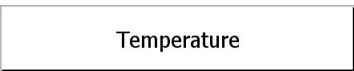

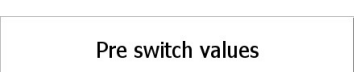
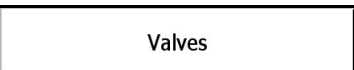
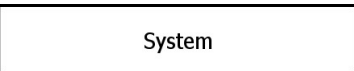





Figure 2 Settings

4.1 Functions

This image takes you to various sub-menus.

4.2 Description of Individual Panels

Button/Indicator	Action	Remark
	☞ Pressing the key	The ,temperature' menu opens.
	☞ Pressing the key	The ,lead/lag' opens.
	☞ Pressing the key	The ,Counters' menu opens.
	☞ Pressing the key	The ,Pre threshold valves' menu opens.
	☞ Pressing the key	The ,Valves overclock' menu opens.
	☞ Pressing the key	The ,System' menu opens.
	☞ Pressing the key	A window in the currently pending error messages opens.
	☞ Pressing the key	The ,Manual operation' menu opens.
	☞ Pressing the key	This button takes you back to the main screen.
	☞ Pressing the key	This button takes you back to the main screen.

5 Temperature Settings

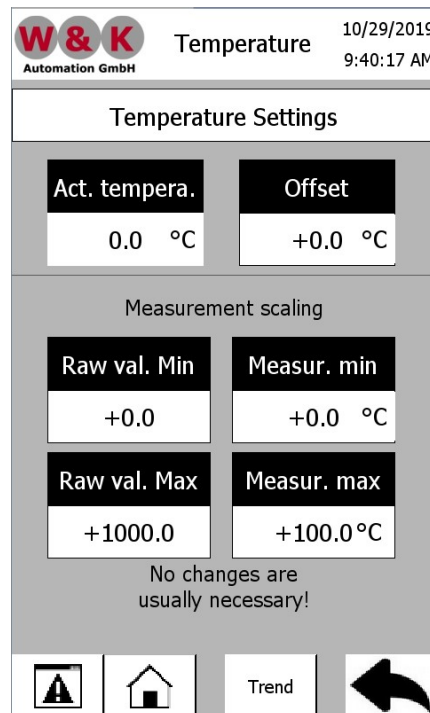









Figure 3 Temperature Settings

5.1 Functions

In this menu you can set the temperature measurement. The settings on this screen are usually necessary once during startup.

5.2 Description of Individual Panels

Button/Indicator	Action	Remark
	Display	The current temperature is displayed here.
	 Setpoint	Here you can enter an offset for the temperature. Procedure is as follows : Example:- Dose 20l water with a target temperature of 25 ° C in a container. At the end the temperature of the water in

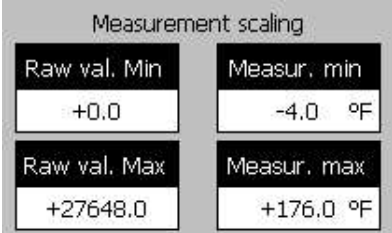
Button/Indicator	Action	Remark
		<p>the tank and the temperature that is displayed on the main page on the display should be 25 ° C. There is a difference between the temperature of which is shown on the display and the measured water temperature in the container this must be adapted to the off-set. If the display temperature for example is 25 ° C and the sample temperature is 23 ° C, then an offset is to be entered of -2 ° C. If the display is 25 ° C and the water temperature in the tank is 27 ° C, then an offset must be entered of +2 ° C.</p> <p>Please try again after changing the offset. If before an offset is already specified, the newly determined offset must be added to the old.</p>
	<p>☞ Pressing the key</p>	<p>A window in which the current present error messages are displayed opens.</p>
	<p>☞ Pressing the key</p>	<p>This button takes you back to the main screen.</p>
	<p>☞ Pressing the key</p>	<p>Clicking this button will open a picture of the course of the tempature over the last few minutes.</p> <p>You can also leave using this key.</p> 
	<p>☞ Pressing the key</p>	<p>Use this button to return to the settings menu.</p>
	<p>☞ References Scalling Reading</p>	<p>Changes in these input fields are only necessary during commissioning and after a change of the temperature sensor. Usually, the "raw value Min" = 0 and the "raw value Max" = 27648</p> <p>This is also the resolution of the analog input card of the controller.</p>

<i>Button/Indicator</i>	<i>Action</i>	<i>Remark</i>
		Input signal 0-10V = 0-27648 The "Min measured value" and "Max measured value" is to be taken from the operating instructions of the temperature evaluation.

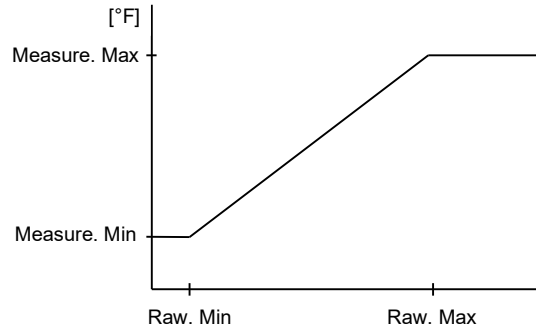

Figure 4 Raw value / measurement value

6 Temperature Trend

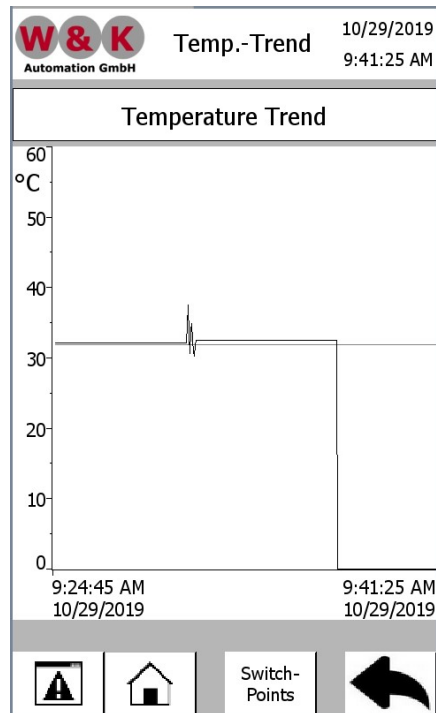
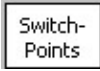



Figure 5 Temperature Trend

6.1 Functions

Here you can see the temperature trend of the last minutes.

6.2 Description of Individual Panels

<i>Button/Indicator</i>	<i>Action</i>	<i>Remark</i>
	 Pressing the key	The ,Switch Points' menu opens.

7 Temperature switching points

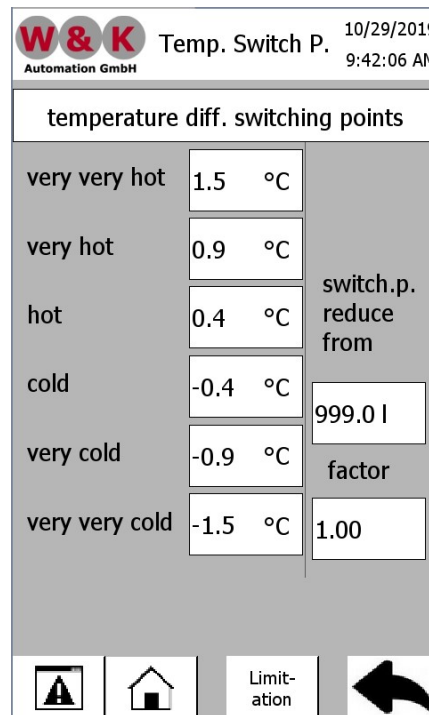

Figure 6 Temperature switching points

7.1 Functions

Here you can decide, at which temperature difference the different Valve combination will switch on. The next higher/lower switching point is the hysteresis.

Very very hot -> Icewater

Very hot -> Raw water / Ice water

Hot -> Raw water

Cold -> Raw water

Very Cold -> Rawwater / Hot water

Very Very cold -> Hot water

From when switching points reduce ": From this metered quantity, the switching points are multiplied by the factor. For example, if 100l to be dosed and switching point decrease from stands at 50l, then the switching points would be multiplied by the factor from 50l. If the switching point is very hot at 2 ° C and the factor to 0.5 then

would be the very hot switching point 50l 1 ° C. This allows the target temperature to be reached more precisely with larger quantities

7.2 Description of Individual Panels

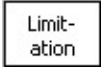
<i>Button/Indicator</i>	<i>Action</i>	<i>Remark</i>
	☞ Pressing the key	The ,Limitation' menu opens.

7.3 Limitations Citywater/Eiswater/Max-Temperature

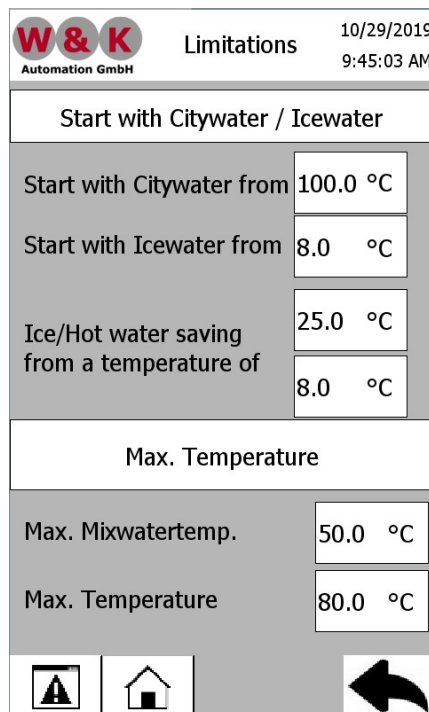

W & K Automation GmbH Limitations 10/29/2019 9:45:03 AM

Start with Citywater / Icewater

Start with Citywater from 100.0 °C

Start with Icewater from 8.0 °C

Ice/Hot water saving from a temperature of 25.0 °C

8.0 °C

Max. Temperature

Max. Mixwatertemp. 50.0 °C

Max. Temperature 80.0 °C



  

Figure 7 Limitations

7.3.1 Functions









Here you can set, from which target temperatures under no circumstances Ice water or water will be used, even if the target temperature is far below/over. This target

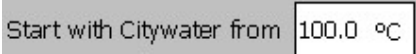

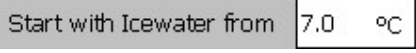

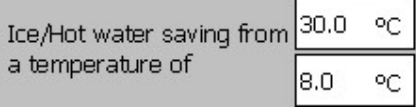

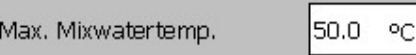

temperate will be used instead. This saves grade at the start of dosing, when there may be over-vibrators, ice / hot water.

In order to start dosing without hot water, set the function "with city water start". In the first few seconds of dosage only city water will be used. This prevents directly dosing with hot water at the start and destroying yeast.

 The features of this menu may be used only when everything is connected and active. Otherwise these functionalities must be deactivated so that no undesirable operating conditions occur.

7.3.2 Description of Individual Panels

Button/Indicator	Action	Remark
	 Setpoint	If the target temperature is higher than this value, the first few seconds of the dosage will be started with city water.
	 Setpoint	If the desired temperature is lower than this value, the first few seconds of dosage will be started only with ice water.
	 Setpoint	<p>If the temperature set point is above the limit value (above) no ice is used. To disable, set the upper value to 100.0.</p> <p>If the temperature setpoint is below the threshold (below), no hot water is used. To disable, set the lower value to 0.0.</p>
	 Setpoint	If the mixed water temperature is exceeded, the hot water valve is closed and the city water valve is opened, so that the temperature is lowered. If you would like switch off the function, set the parameter to 100 °C.

<i>Button/Indicator</i>	<i>Action</i>	<i>Remark</i>
	 Setpoint	If the Maximum temperature is exceeded at the temperature sensor, the city water valve is additionally opened so that the temperature is lowered. To disable, set to 100 ° C.
	 Press the key	A window in the currently pending error messages are displayed open.
	 Press the key.	This button takes you back to the main screen
	 Press the key	This button brings you back to the switching points menu

8 Pre run / Ice water pre run

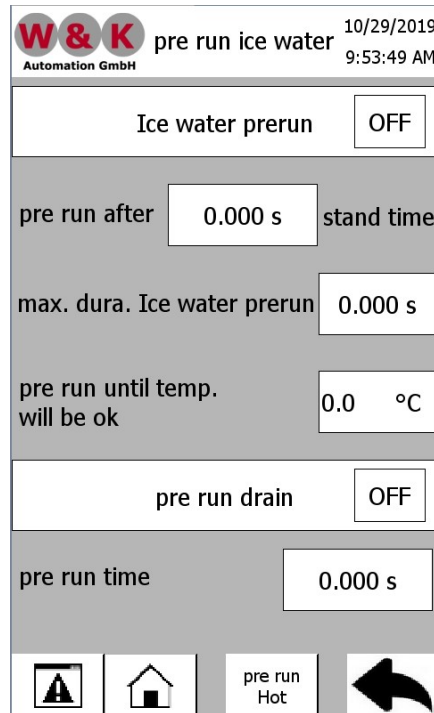



Figure 8 Pre Run Icewater

8.1 Functions

 This image:- two different pre run types can be switched on. The pre run functions may only be switched on if an extra "channel valve" is available.







Ice water pre run

If the ice flow is switched on, check each dosing, since the last use of the ice water has passed than the time set for a long time. Then the ice water valve and the drain valve is opened before the actual dosing. The two valves remain open until the max set of ice-water flow duration has expired or the set temperature value is reached.

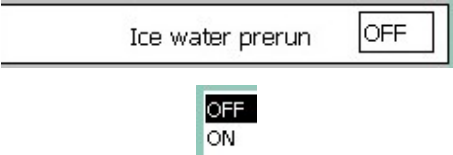
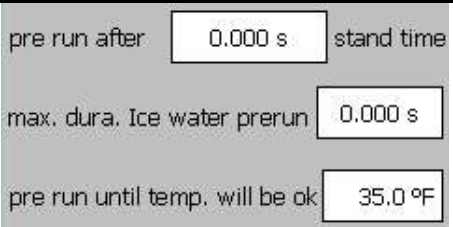
Pre run

If this function is turned ON, open the drain valve for an adjustable time before each dose.

8.2 Description of Individual Panels

Button/Indicator	Action	Remark
 <p>Ice water prerun OFF</p> <p>OFF ON</p>	☞ Selection Field	The drop down box can be used to turn the ice ON and OFF.
 <p>pre run after: 0.000 s stand time</p> <p>max. dura. Ice water prerun: 0.000 s</p> <p>pre run until temp. will be ok: 35.0 °F</p>	☞ Setpoint input fields for the ice water resources.	Here the above set-points for ice-leading can be adjusted.
 <p>pre run drain OFF</p> <p>OFF ON</p>	☞ Selection Field	Through this selection field the the flow channel function can be switched ON and OFF.
 <p>pre run time 0.000 s</p>	☞ Setput Inpoint Field	The surrounding drain valves remain open before dosing.
	☞ Press the key	A window in the currently pending error messages are displayed open.
	☞ Press the key.	This button takes you back to the main screen
 <p>pre run Hot</p>	☞ Press the key	This button takes you tot he hot water supply.
	☞ Press the key	This button brings you back to the settings menu.

9 Pre run hot water

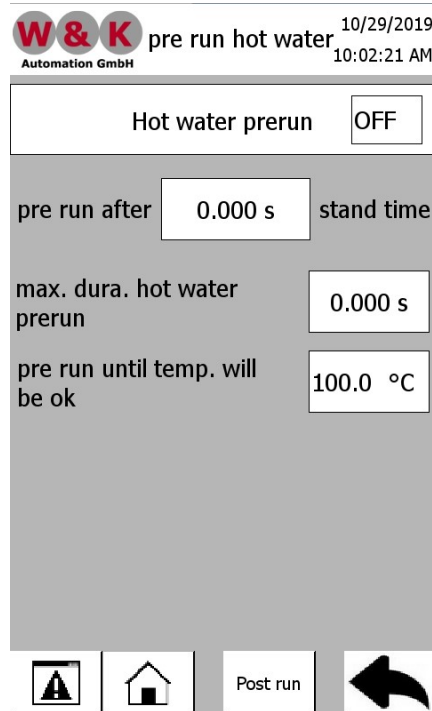



Figure 9 Pre Run Hot water

9.1 Functions





About this image, the hot water supply can be switched on.

 The flow functions may only be switched on if an extra "channel valve" is available!

Hot Water pre run

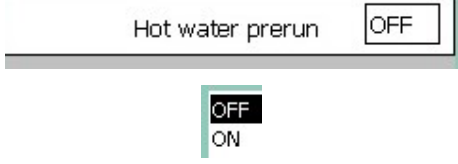
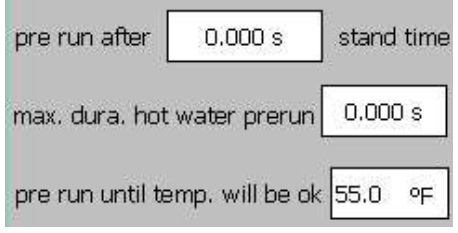
If the hot water supply is switched on, check after each dosing, since the last use of the hot water is passed a time longer than the set time. Then the hot water valve and the drain valve is opened before the actual dosing. The two valves remain open until the max hot water flow duration expires or is exceeded preset temperature value.

9.2 Description of Individual Panels

<i>Button/Indicator</i>	<i>Action</i>	<i>Remark</i>
 <p>Hot water prerun <input type="button" value="OFF"/></p> <p><input type="button" value="OFF"/> <input type="button" value="ON"/></p>	☞ Selection Field	Through this selection field the hot water forward can be switched ON and OFF
 <p>pre run after <input type="text" value="0.000 s"/> stand time</p> <p>max. dura. hot water prerun <input type="text" value="0.000 s"/></p> <p>pre run until temp. will be ok <input type="text" value="55.0 °F"/></p>	☞ Setpoint input fields for the hot water leading	Here the above setpoints for the hot water flow can be adjusted.
	☞ Pressing the Key	A window in the currently pending error messages are displayed.
	☞ Pressing the Key	This button takes you back to the main screen.
	☞ Pressing the Key	This button takes you to the image "lag".
	☞ Pressing the Key	Use this button to return to the settings menu

10 Post run

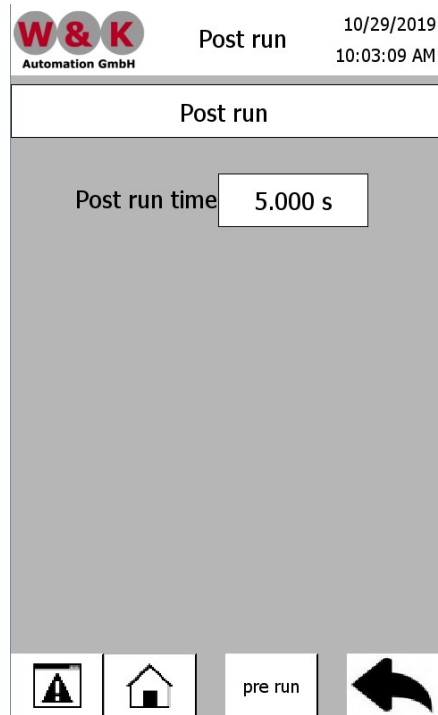

Figure 10 Post run

10.1 Functions

By pressing the "lag" in the run menu you can access this file. Here you can set the delay time.





Post run

The valves close at the end of the dosage if the

Value is = target - pre-threshold value.

Balancing effects can continue to run water and are registered by the MID. This is registered during the follow-up time and included in the calculation. Due to the arrangement of the valves in this WAMI only a short follow-up time is necessary.

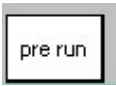
10.2 Description of Individual Panels

<i>Button/Indicator</i>	<i>Action</i>	<i>Remark</i>
	☞ Setpoint	Here the nominal duration of the lag can be entered.
	☞ Pressing the Key	A window in the currently pending error messages are displayed open.
	☞ Pressing the Key	This button takes you back to the main screen.
	☞ Pressing the Key	This button takes you back to the screen "forward".
	☞ Pressing the Key	This button brings you back to the settings menu.

11 Counter

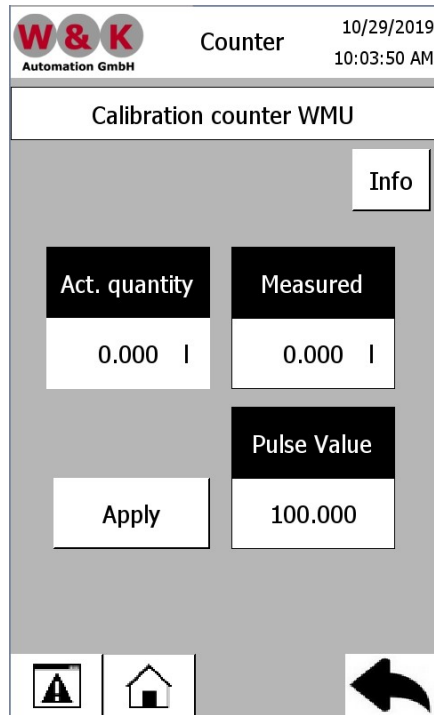

Figure 11 Counter

11.1 Functions







From this menu, the pulse value of the water meter can be adjusted.

"Actual value" is the amount of value that the WAMI is working at, at the moment. It is calculated from the flow pulses and the pulse value.

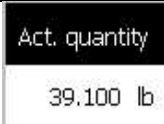
"Measured" is the value that has been gauged. So the value is actually true.

Action: Dispensing water into a measuring container. If the amount is different in your measuring container of the actual value, enter the measured quantity in the field "measured" one. Then press the "Apply" button. Repeat this procedure until the accuracy of your needs are met.

11.2 Explanation Of the Individual Panels

Button/Indicator	Action	Remark
	☞ Istweranzeige	" Actual value "is the amount of value that the WAMI working at in that moment. It is calculated from the flow pulses and the pulse value.
	☞ Setpoint	" measured "is the value that has been gauged. So the value is actually true.
	☞ Setpoint	Current pulse value. An equivalence of eg 100 says that issues of water meter 100 pulses per liter.
	☞ Press the Key	Action: dispensing water into a measuring container. If the amount is different in your measuring container to the actual value, enter the measured quantity in the field "measured" one. Then press the "Apply" button. Repeat this procedure until the accuracy of your expectations corresponds.
	☞ Press the key	A window in the currently pending error messages are displayed open.
	☞ Press the key	This button takes you back to the main screen.
	☞ Press the key	Use this button to return to the settings menu.

12 Pre Switch Values

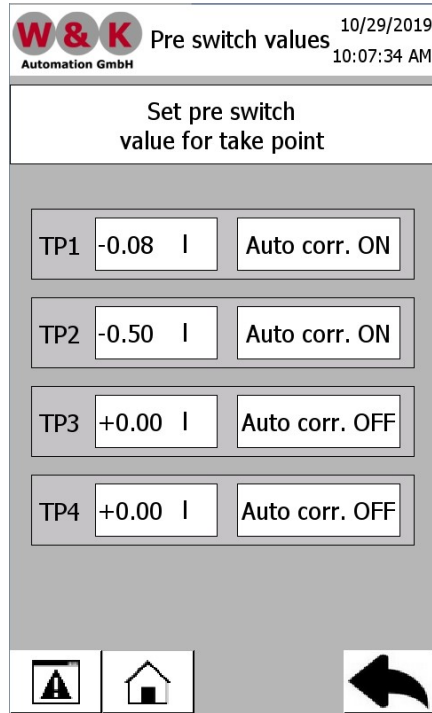
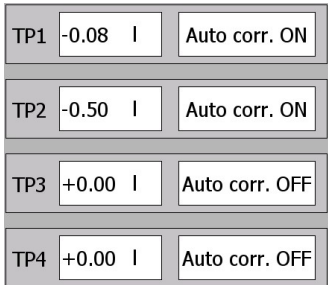





Figure 12 Set pre switch

12.1 Description of Individual Panels

Button/Indicator	Action	Remark
	 Setpoints pre-switching values	<p>In this mask, the pre-threshold values for the different sampling points can be set. If you only have one tapping point, only the ES1 is relevant. The pre-threshold value indicates how many liters of the valves close before reaching the target value itself. This</p>

<i>Button/Indicator</i>	<i>Action</i>	<i>Remark</i>
		value is necessary because, inter alia, the valves require a certain amount of time to close. During this time, water still flows. For this reason, the closing command is given before reaching the target value.
<div style="border: 1px solid black; padding: 5px; width: fit-content;"> Auto corr. OFF Auto corr. ON </div>	☞ Selection Field	This field can be given to, whether the pre-threshold value is to be optimized itself. If the auto-correction is on, the controller compares after each dosing whether the actual value = target value. If this is not the case, the controller corrects the pre-threshold value in the corresponding direction.
	☞ Pressing the key	A window will appear in which the currently pending fault messages open.
	☞ Press the key	This button takes you back to the main screen.
	☞ Press the key	Use this button to return to the settings menu.

13 Valves

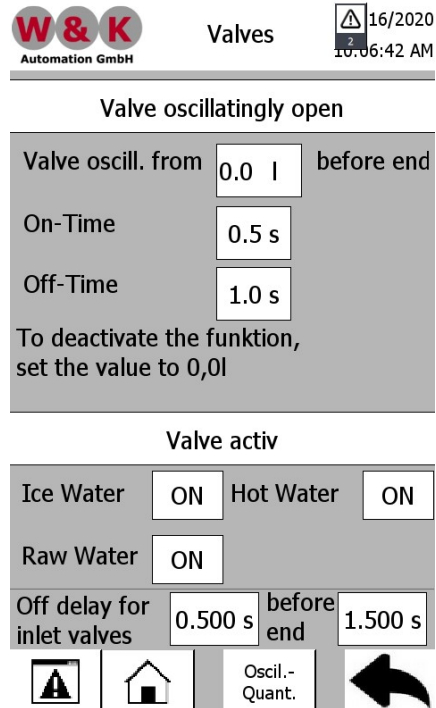



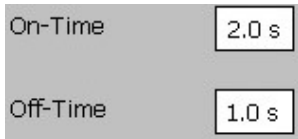











Figure 13 valves overclock

13.1 Functions

At high water pressures and resulting high flow rates, it may be advisable that the sampling valves are timed just before the end. Thereby, the dosage amount accuracy must be improved.

13.2 Description of Individual Panels

Button/Indicator	Action	Remark
Valve oscillatingly <input type="text" value="0.0 l"/> before end	 Selection field	This parameter can be set with how many liters should be started before reaching the setpoint value with the valve intact.

<i>Button/Indicator</i>	<i>Action</i>	<i>Remark</i>
	 Selection field	Here, the target values for which can be set to ON-OFF time of the valves during the cycle. It applies in principle: the longer the off time and the shorter the duration, the more accurate the dosage amount accuracy. However, thus prolonging the dosing time.
	 Selection field	If a kind of water is not available, the kind can be switched off here.
	 Selection field	Here you can set how long the supply valves are to be switched off during normal operation and how long they are to be delayed, 3l before the end of dosing. This is to ensure that the WAMI system is always under pressure and that the outlet valves can close safely, as they need a pressure difference to close.
	 Pressing the Key	A window will appear in which the currently pending fault messages open.
	 Pressing the Key	This button brings you back to the main image.
	 Pressing the Key	Use this button to return to the settings menu.

13.3 Cycling Small Amounts

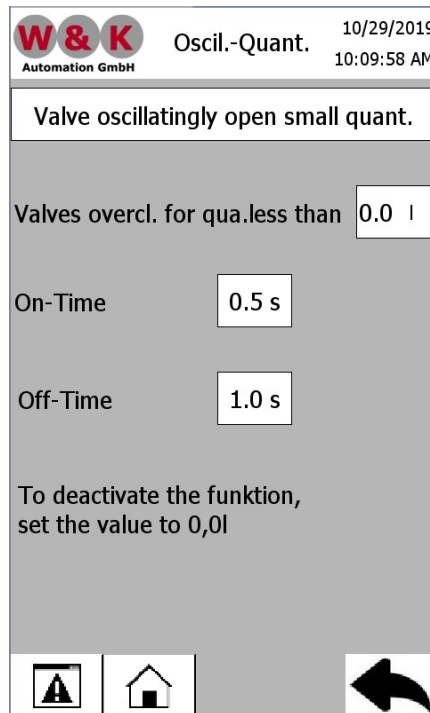
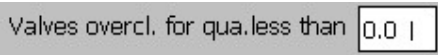

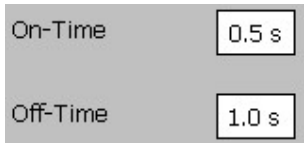







Figure 14 Cycling small amounts

13.3.1 Function Descriptions

When the desired amount is small, greater accuracy can be achieved by entering smaller desired values. This will cause the Valves to cycle more when using small desired amounts.

13.3.2 Explanation of the individual panels

Button/Status	Action	Notes
	desired value	If the desired amount is less than this value the valve will be activated. Setting this value to 0 will disable this functionality.

<i>Button/Status</i>	<i>Action</i>	<i>Notes</i>
	 desired values	The cycle times for the valves can be set here. Do not set the opening time to short otherwise the valve will not open.
	 Touch the button	A window that shows the currently pending alarms.
	 Touch the button	This button will take you back to the main screen.
	 Touch the button	This button will take you to the valve menu.

14 System Images

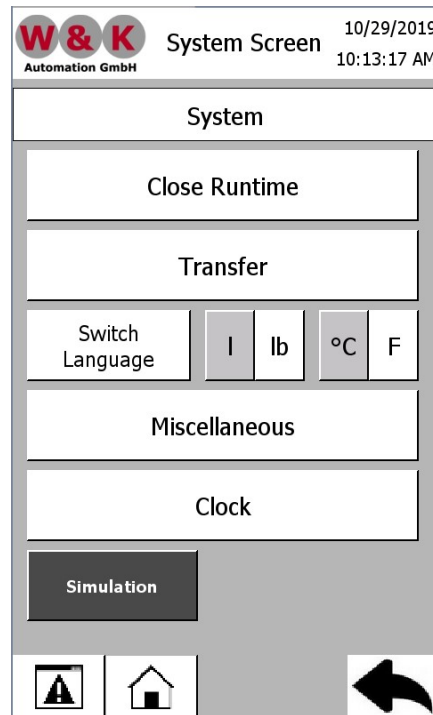

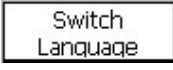

















Figure 15 System menu

14.1 Description of Individual Panels

<i>Taste/Anzeige</i>	<i>Aktion</i>	<i>Bemerkung</i>
	☞ Pressing the button	Use this button to visualize the HMI device to be terminated. This is not necessary in normal operation!
	☞ Pressing the button	This button the HMI device is placed on the transfer mode. This is not necessary in normal operation!
	☞ Pressing the button	It is planned at the moment no language switching.

Taste/Anzeige	Aktion	Bemerkung
	 Pressing the button	Use this button to switch the quantity unit and the temperature unit.  After switching the quantity unit, the Counter has to be calibrated.
	 Pressing the button	This button takes you to the "Others" menu
	 Pressing the button	This button takes you to the "Time" menu. In the Time menu, you can set the time of the WAMI.
	 Betätigung der Taste	Via the button simulation, the simulation is turned on. If simulation is active, an error message is generated. In simulation mode, the actual temperature and the actual amount are simulated.  In simulation mode, the valves will be actuated! Water can also flow in simulation mode!
	 Pressing the button	Be a window that displays the currently pending fault messages open.
	 Pressing the button	This button takes you back to the main screen
	 Pressing the button	Use this button to return to the settings menu.

15 "Miscellaneous" Menu

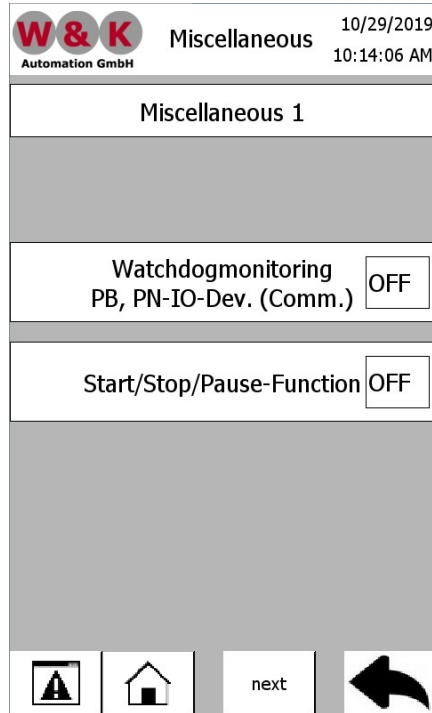

Figure 16 Miscellaneous

15.1 Functions

Watchdog

If a communication via Profibus or Ethernet Serial is enabled, the watchdog can be switched off using this menu item.

Start/Stop/Pause Function

See "Other" menu.

This function can be set as to react to the start of the digital input WAMI.

The inputs are wired as follows.

<i>Clamp</i>	<i>Input Control</i>	<i>Remark</i>
X2.1		24V supply for buttons
X2.2	I0.1	Start (Start/Pause/Stop)

<i>Clamp</i>	<i>Input Control</i>	<i>Remark</i>
X2.3	I0.2	Jog mode
X2.4	I0.3	Pulse mode
X2.5	I0.4	Start water (for example, from external control)

<i>Clamps</i>	<i>Input Control</i>	<i>Remark</i>
X1.11-12	Q4.3	Water ready - message

If the start / stop / pause function is disabled, the start input I0.1 can be used as a normal start button or be controlled by a starter contact an external control. On a rising edge, the dosage is started.

If the start / stop / pause function is activated, all three commands on the input I0.1 can be given. If not metered at the moment, a dosing is started by a short activation of the input.

During dosing, can be paused for a short activation of receipt of the dispensing process. If you repeat this short activation of the pause input is terminated.

If the input is for a longer time than 0.5 seconds on, the dispensing process is stopped.







As long as the jog mode is active, city water is metered. By repeatedly pressing the amounts are added up. If 20s was not long typed the Jog mode is disabled. Tap again the quantity counter is reset to 0. By pressing the Start or Stop button on the jog mode is terminated.

The input for the stop is executed against wire breakage. If 24V at the input are located on-not stop when 0V is applied to the active stop.

The input "start water" can be retriggered by an external controller. If an edge is a Dosing is started.

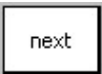
The output "water ready" is set for 2 seconds when a dosing is completed.

15.2 Description of Individual Panels

Button/Indicator	Action	Remark
	☞ Selection Field	About this check box, the function described above can be turned ON.
	☞ Selection Field	About this check box, the function described above can be turned ON.
	☞ Pressing the button	This takes you to Miscellaneous 2
	☞ Pressing the button	A window in the currently pending error messages are displayed open.
	☞ Pressing the button	This button takes you back to the main screen.
	☞ Pressing the button	Use this button to return to the Settings menu

15.3 "Miscellaneous 2" Menu

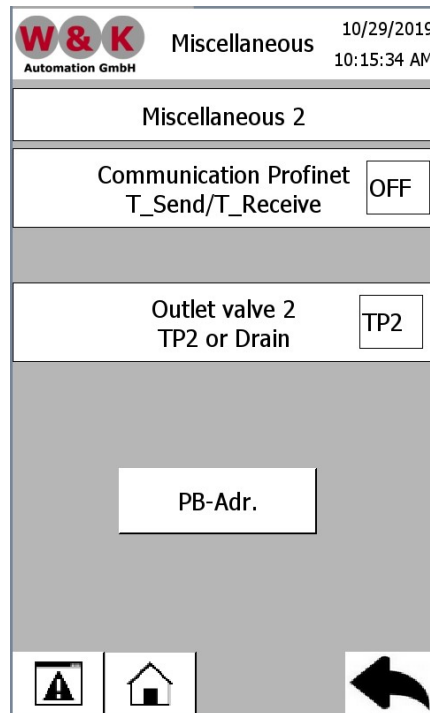





Figure 17 Miscellaneous 2

15.3.1 Functions

In this menu, you can decide whether the Profinet communication is switched on / off. Also you can configure, whether the outletvalve 2 is the Taking Point 2 or the drain valve. If you would like to use the pre run functions, you have to configure the valve as drain valve.

15.3.2 Description of Individual Panels

Button/Indicator	Action	Remark
Communication Profinet T_Send/T_Receive <input type="checkbox"/> OFF	☞ Selection Field	About this check box, the function described above can be turned ON.
Outlet valve TP2 or Drain <input type="checkbox"/> TP2	☞ Selection Field	About this check box, the

<i>Button/Indicator</i>	<i>Action</i>	<i>Remark</i>
		function described above can be turned to TP2 or drain.
	☞ Pressing the button	This Button opens the screen "Profibus"
	☞ Pressing the button	A window in the currently pending error messages are displayed open.
	☞ Pressing the button	This button takes you back to the main screen.
	☞ Pressing the button	Use this button to return to the Miscellaneous 2 menu

15.4 "Profibus" Menu

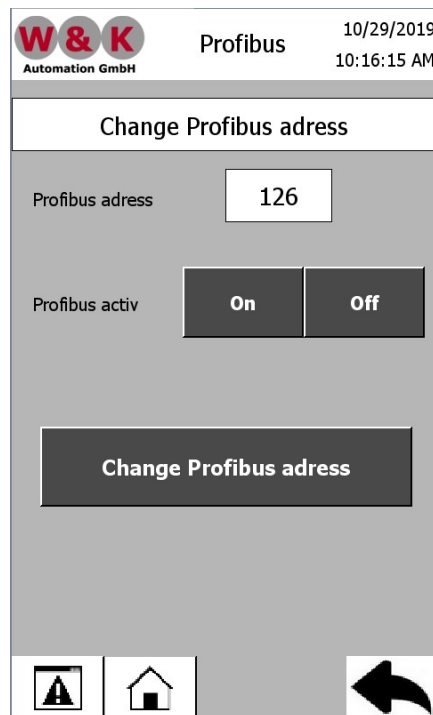















Figure 18 Profibus

15.4.1 Functions

In this menu, the Profibus address is set. This is only possible if a Profibus communications processor is installed. By default the Profibus address 126 is set. At every restart of WAMI's the Profibus address is 126 occupied for a short time. Even if another address is set. This is by design.

 No other Profibus participants can use the address 126 as it will cause unwanted noise/disturbances.

15.4.2 Description of Individual Panels

Button/Indicator	Action	Remark
	 Enter values into the field	The new address can be set here. After changing the address either the button below must be actuated or the WAMI must be made voltage loss for the new address to take effect.
	 Pressing the button	If the Profile bus function is used set this to on. (ein)
	 Pressing the button	Change the profile bus address
	 Pressing the button	A window in the currently pending error messages are displayed open.
	 Pressing the button	This button takes you back to the main screen.
	 Pressing the button	Use this button to return to the Miscellaneous 2 menu

16 Manual Operation

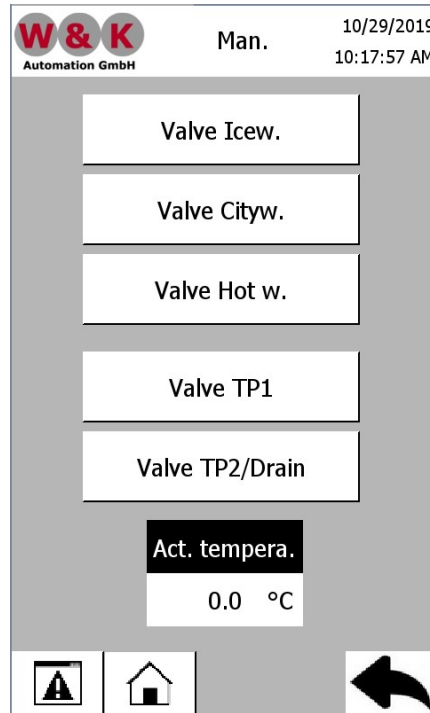

Figure 19 Manual operation

16.1 Functions

About the button in this menu, the individual valves can be actuated. For safety reasons the manual command is automatically reset after 60s again.

16.2 Description of Individual Panels

<i>Button/Indicator</i>	<i>Action</i>	<i>Remark</i>
<div style="border: 1px solid black; padding: 2px; margin-bottom: 2px;">Valve Icew.</div> <div style="border: 1px solid black; padding: 2px; margin-bottom: 2px;">Valve Cityw.</div> <div style="border: 1px solid black; padding: 2px; margin-bottom: 2px;">Valve Hot w.</div> <div style="border: 1px solid black; padding: 2px; margin-bottom: 2px;">Valve TP1</div> <div style="border: 1px solid black; padding: 2px;">Valve TP2/Drain</div>	Pressing the button	Use this button you can control the valves.

17 Error Messages

<i>MESSAGE</i>	<i>REMARK</i>
Fuse fail	If wired and activated in the "Other" menu displays this message that the external circuit breaker is tripped.
Disorder no water	The valves are on, but there is no flow measured. This may, inter alia, the following reasons: - Water pressure too low - Valve defective Restricted line - - Water flows are not measured but -> flowmeter defective
Communication alarm Watchdog	This message can appear only if it is enabled in the "Other" menu. It indicates that there are problems communicating to the partner control.
Simulation ON	This message appears when the simulation mode is turned on in the System menu. If the simulation is ON a normal operation of the WAMI is not possible since the measurement values are simulated.

18 Installation instructions

18.1 Water connections of WAMI TYPE III

The WAMI TYPE III has three water inlets and two water outlets. For easy mounting all valves are equipped in $\frac{3}{4}$ " with external thread. Check valves are also integrated in the inlets so that only one filter and one pressure reducer are required for each type of water to integrate into your production.

The pressure reducers must be set equally to the lowest water pressure of a variety so that no water type has "priority". According to experience, this is between 1.5 and 2.5 bar.

In order to prepare the assembly in advance, the drawings of the connections are attached:

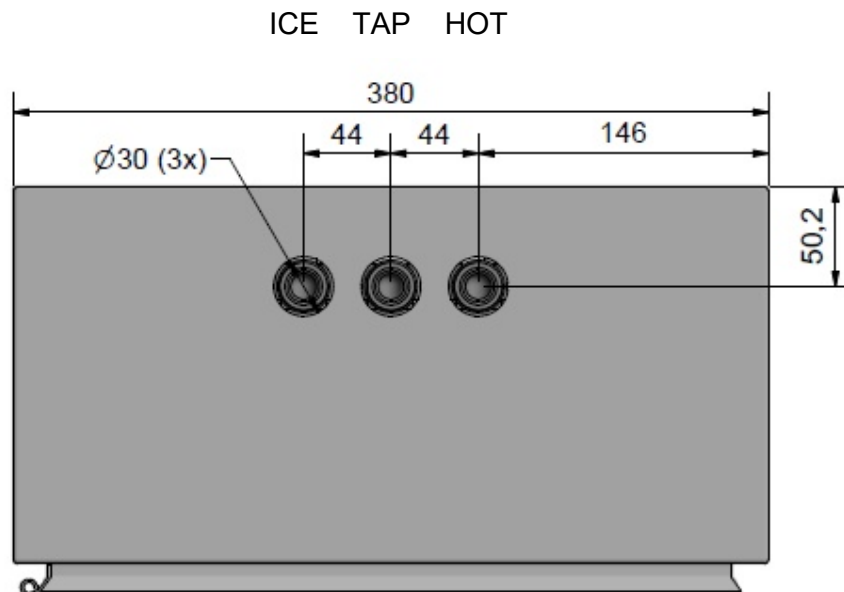

Figure 20 Water types WAMI III

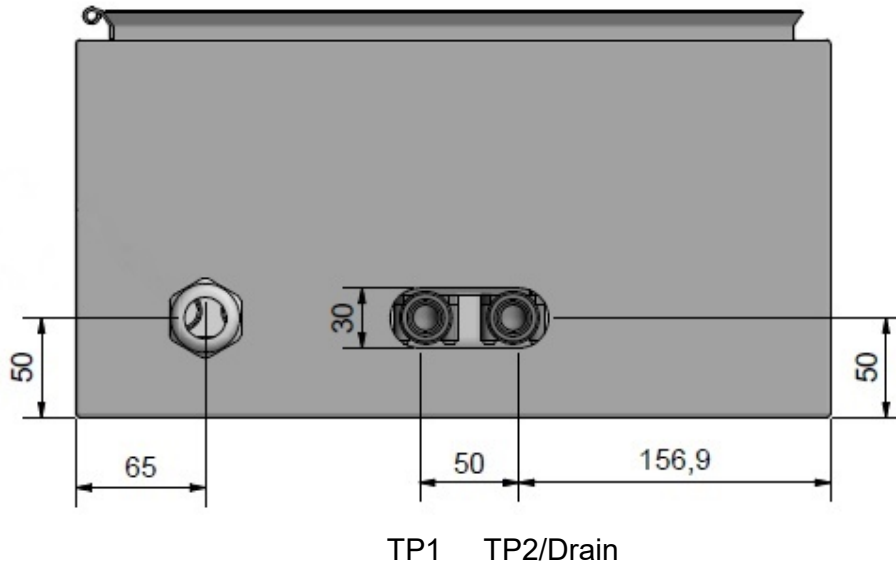

Figure 21 Water outlet WAMI III

With the second water outlet you can either feed a second take point or you can use the drain function. The drain function monitors the water temperature. If e.g. the device was inactive for several hours and the supply temperatures did not have the optimum value in the flow, a pre-run is first made in the drain.

18.2 Water connections of WAMI TYPE IV

The WAMI TYPE IV has three water inlets and two water outlets. All valves are equipped in 1" with external thread. For integration into your production, a non-return valve, a filter and a pressure reducer must be provided for each type of water.

The pressure reducers must be set equally to the lowest water pressure of a variety so that no water type has "priority". According to experience, this is between 1.5 and 2.5 bar.

In order to prepare the assembly in advance, the drawings of the connections are attached:

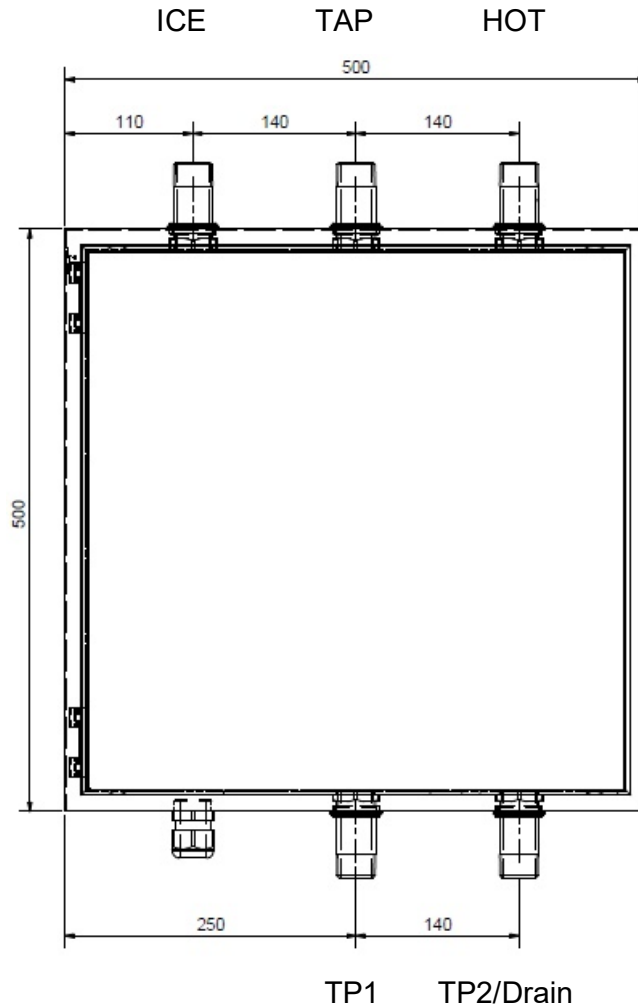

Figure 22 Water types WAMI IV

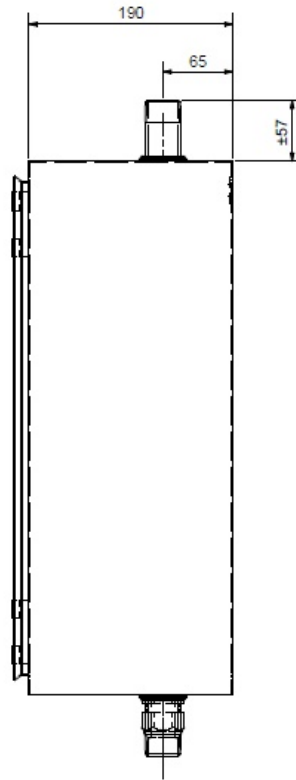

Figure 23 Side view WAMI IV

With the second water outlet you can either feed a second take point or you can use the drain function. The drain function monitors the water temperature. If e.g. the device was inactive for several hours and the supply temperatures did not have the optimum value in the flow, a pre-run is first made in the drain.

19 List of Figures

Figure 1 Main Screen	7
Figure 2 Settings	10
Figure 3 Temperature Settings	12
Figure 4 Raw value / measurement value	14
Figure 5 Temperature Trend.....	15
Figure 6 Temperature switching points.....	16
Figure 7 Limitations	17
Figure 8 Pre Run Icewater.....	20
Figure 9 Pre Run Hot water	22
Figure 10 Post run	24
Figure 11 Counter.....	26
Figure 12 Set pre switch	28
Figure 13 valves overclock	30
Figure 14 Cycling small amounts.....	32
Figure 16 System menu	34
Figure 17 Miscellaneous.....	36
Figure 18 Miscellaneous 2.....	39
Figure 19 Profibus	40
Figure 20 Manual operation.....	42
Figure 21 Water types WAMI III.....	44
Figure 22 Water outlet WAMI III	45
Figure 23 Water types WAMI IV	46
Figure 24 Side view WAMI IV	47

Changes:

- 31.07.2015 V1.8 Switch off water kinds
- 31.07.2015 V1.8 max. Mixed water temperature
- 02.06.2016 V1.9 Profile bus address can be changed; introduced factor in switching points.
- 15.06.2016 V1.10 Capital: Cycling small amounts
- 17.06.2016 V1.11 Menu restrictions added. Moved MAX temperatures. Added City water start, saving ice start and hot water reducing. Simulation inserted in the system menu.
- 22.08.2016 V1.12 Switching temperature and quantity unit
- 29.01.2018 V1.13 chapter 18 replaced. New: Installation Instructions
- 29.10.2019 V1.14 pictures exchanged
- 16.06.2020 V1.16 Chapter 13 Valves. Supply valves Switch-off delay inserted.