

Varimixer

# AR30

## MULTIPLE CAPACITIES IN ONE MACHINE

Bowls and tools for production at half volume are available for AR30

## DIGITAL TIMER

Mixing time can be adjusted and monitored on the digital timer. The mixer will stop at 00:00 and signal a beep to notify the operator.

## MEAT MINCER AND VEGETABLE CUTTER

Models from AR30 to AR80 can be ordered with an attachment drive, to expand the mixer's potential applications.

## MAGNETIC SAFETY GUARD

The front and rear of the guard can easily be removed and washed in a dishwasher. This makes the cleaning of the machine much easier and ensures optimum hygiene.

## AUTOMATIC FIXATION

The bowl is wheeled into place between the two bowl arms. Using the handle - or automatically by pressing a button - the bowl is raised, centered and locked in place in a single movement.

## EASY BOWL HANDLING

Choose between bowl truck for transport or an electric bowl lift, which handles transport to and from the machine. This also ensures good ergonomics during filling and emptying. Choose between several models.

## STAINLESS STEEL LEGS

As extra protection against rust, the vertical part of the legs are always made of stainless steel.

## STRONG AND EFFECTIVE

The powerful motors have the capacity to handle large quantities of heavy ingredients.

## VARIABLE SPEED CONTROL

The speed is variably controlled by a very rugged system of belts, rather than gears. This solution means that the mixer does not contain oil, thus avoiding the risk of oil spilling into the bowl.



## WHITE OR STAINLESS STEEL

An easy-to-clean design. The AR series is powder coated as standard and can be upgraded to a completely stainless steel frame.

**VARIMIXER AR30 OPTIONS – MODELS**



White, powder coated



Stainless steel



Marine version, stainless steel

**OPTIONS – CONTROL PANEL**



VL-1 – Manual speed regulation and manual bowl lowering



VL-1S – Automatic speed regulation and automatic bowl lowering

**OPTION – SAFETY GUARD WITH GRID**



Stainless steel grid guard.  
Not CE-certified

**OPTIONS – ATTACHMENT DRIVE**



Attachment drive for meat mincer and vegetable cutter



Meat mincer, 70 mm



Meat mincer, 82 mm



Vegetable cutter GR20

**VARIMIXER AR30 STANDARD TOOLS – A-EQUIPMENT 30L**



Whip, hook, beater and bowl 30 liter in stainless steel.

**VARIMIXER AR30 STANDARD TOOLS – B-EQUIPMENT 30/15L**



Whip, hook, beater and bowl 30/15 liter in stainless steel.

**OPTION – TOOLS**



Wing whip, stainless steel



Whip with 1 mm thicker wires, stainless steel



Whip with thinner wires, stainless steel

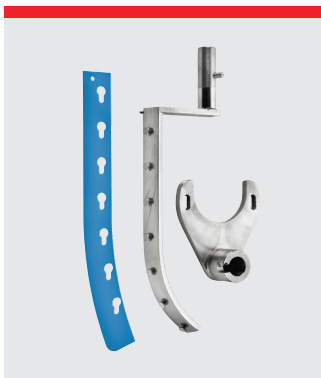

Automatic scraper, stainless steel. 30L and 30/15L.



Powder mixer, stainless steel



Tool rack

**EQUIPMENT**



Bowl truck



Easylift 30-60



Multilift 30-60



Flexlift Inox

## VARIMIXER AR30 STANDARD

White powder coated
1 bowl 30 liter in stainless steel
1 beater in stainless steel
1 hook in stainless steel
1 whip with stainless steel wires
Magnetic removeable safety guard – CE-certified
Digital timer and emergency stop
Voltage: 3 ph, 400V, 50 Hz with 0 and ground. 1.000 W

## VARIMIXER AR30 STANDARD TECHNICAL DATA

Volume	30 l
Effect	1.000 W
Voltage*	400 V
Residual current devices (RCD):	
Industrial environment	PFI type A
Light industry/domestic	HPFI type A
Net weight	167 kg
Shipping gross weight	195 kg
H x W x L (Shipping dimensions)	1430 x 680 x 1120 mm
H x W x L (Product dimensions)	1209 x 541 x 938 mm
HS Code	84341010
Vol. m <sup>3</sup>	1.06 m <sup>3</sup>
Ldm	0.45
Variable speed	72 - 451 RPM
Phases	3 ph
IP code	IP32

\*Other voltage power supply are available upon request in the range of 100 to 480 V. All standard and marine mixers are available in 50 and 60 Hz.

## VARIMIXER AR30 MARINE VERSION

Stainless steel execution, water cover at air ventilation, slotted free screws, full welded stainless steel knees, gasket at the rear plate, gasket at front panel and top cover. Complies to USPHS.

Voltage: 3 ph, 440V, 50-60 Hz with 0 and ground. 1.000 W  
3 ph, 480V, 50-60 Hz with 0 and ground. 1.000 W

## CAPACITIES

Tools	Product		Special attention
Whip	Egg Whites	1.5 l	
	Whipped cream	6 l	
	Buttercream frosting	12 l	+ □
	Layer Cake Sponges	8 kg	
	Mayonnaise	12 l	+
Beater	Mashed potatoes	16 kg	+
	Cakes	15 kg	
	Icing, Fondant	12 kg	+
	Herb Butter	9 kg	+ □
Hook	Meatball / Vegan meatball mix	18 kg	+
	Pasta, noodles (50%AR)	12 kg	●
	Dough, wheat (50%AR)	15 kg	●
	Dough, wheat (55%AR)	17.5 kg	●
	Dough, wheat (60%AR)	20 kg	●
	Dough, whole wheat (70%AR)	18 kg	
	Dough, rye bread	18 kg	+
	Dough, sourdough bread	18 kg	
	Dough, gluten free	14 kg	

The capacity chart shows the maximum capacity for the specific machine. The testing has been conducted with standard equipment. Therefore, the use of special tools, can result in a different outcome. Always start the machine at the lowest speed. Increase the speed subsequently, taking the product being mixed into account.

Symbols explainer - Recommended actions:

- + = Apply scraper, for the best and most efficient result
- = Always make sure the ingredients are room temperature/soft. If not, this can damage the tools.
- = Recommended to work on low speed.
- = Recommended not to go above medium speed.
- AR = Absorption Ratio (moisture in % of dry matter)

## CERTIFICATIONS



## DIMENSIONS

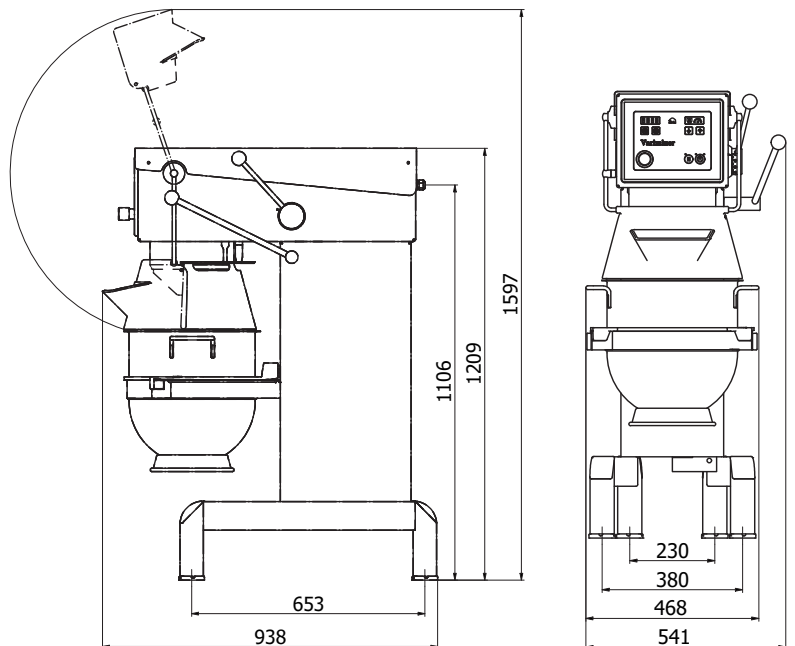

# Varimixer

Varimixer A/S  
Elementfabrikken 9  
DK-2605 Brøndby  
P: +45 4344 2288  
E: info@varimixer.com  
www.varimixer.com