

**GENERAL NOTES:**

- THIS G&A DRAWING IS BASED ON DESIGN EXECUTED BY ELGIN SEPARATION SOLUTIONS FOR PROPOSAL PURPOSE ONLY
- CONFIGURATIONS, DIMENSIONS AND ORIENTATIONS ARE FOR REFERENCE ONLY

# ELGIN SEPARATION SOLUTIONS TANGO-400-HD

- (1) TANK, 1200 GAL. CAPACITY (600 GAL. DIRTY TANK & 600 GAL. CLEAN TANK)
- (3) 250 3X2 CENTRIFUGAL PUMP, BELT-DRIVEN w/15HP PIGGYBACK MOTOR
- (1) 6 CONE 4" DESILTER ASSEMBLY w/ 2" ISOLATION VALVES
- (2) TANGO SHAKER, 4 PANEL DOUBLE DECK w/2HP VIBRATOR MOTORS
- (2) HIGH PRESSURE MUD GUNS, 2" X 5/8 BORE
- (1) 4" MUD HOPPER ASSEMBLY
- (1) ELECTRICAL CONTROL PANEL
- (1) 60 KW GENERATOR SET
- (1) LOW-BOY EQUIPMENT TRAILER, 20,000 LBS. CAPACITY
- (4) MANUAL JACKS, 5K LBS EACH FOR TRAILER
- (1) ELGIN LED LIGHT
- (-) OSHA COMPLIANT HANDRAILS AND CATWALK
- (-) FOLDABLE CATWALK WITH GAS SPRING LIFT ASSIST CYLINDERS
- (-) HIGH/LOW LEVEL SENSOR FOR CLEAN TANK

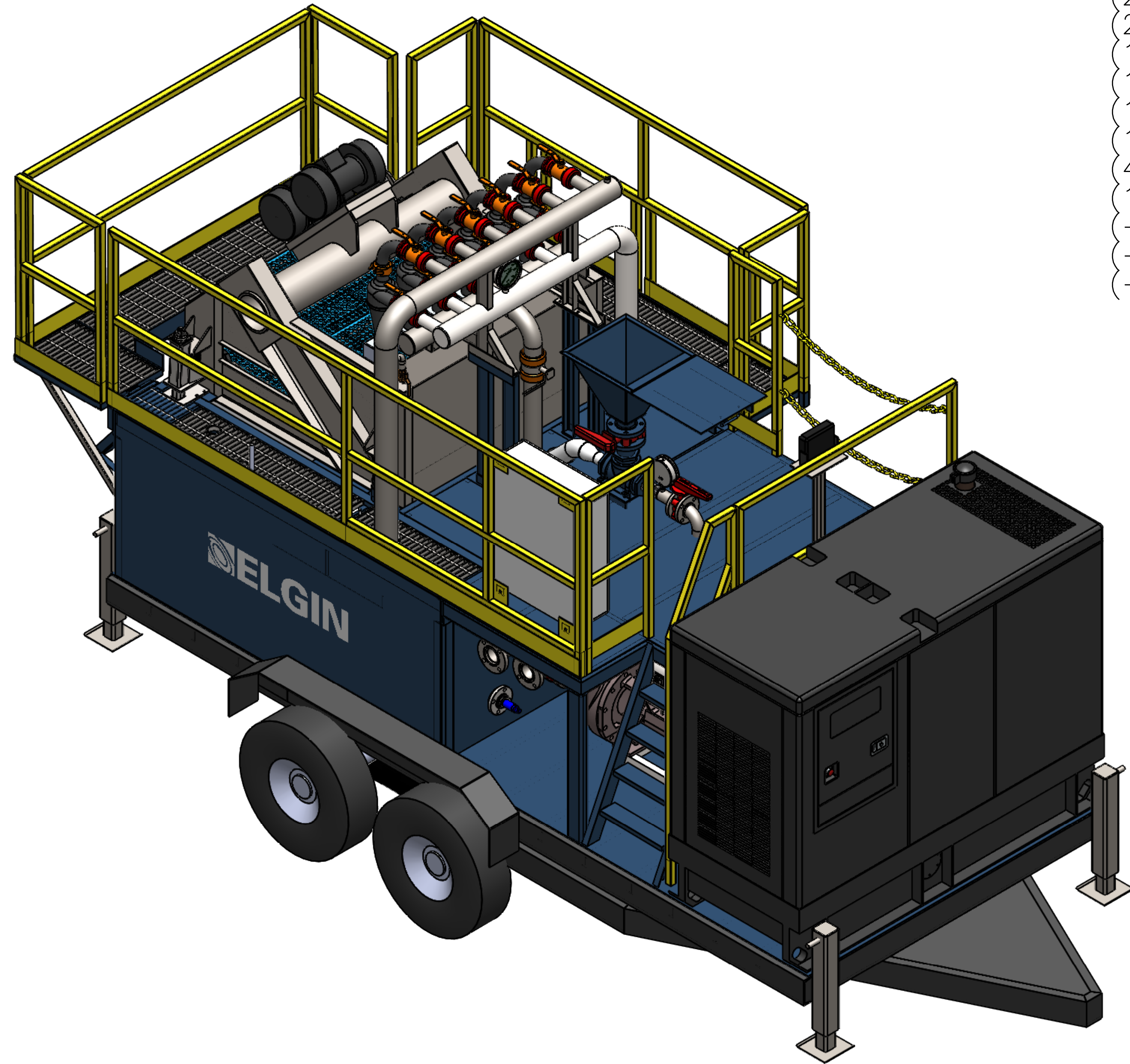

ESTIMATED DRY WEIGHT: 16,500 LBS.

**CONNECTING POINTS:**

- SYSTEM INLET: 1 x 3" ANSI FLANGE
- CLEAN TANK TRANSFER: 1 x 3" ANSI FLANGE
- DESILTER OVERFLOW SAMPLE PORT: 1 x 1" NPT(F) BALL VALVE
- SHEARING HOPPER POWDER INLET: 1 x 1" NPT(F) BALL VALVE

PART NUMBER TANGO-400-HD

**WELDING NOTE (UNLESS OTHERWISE NOTED)**

- 1) ALL WELDS SHALL BE CONTINUOUS.
- 2) ALL FILLET WELDS SHALL HAVE EQUAL LEGS.
- 3) FILLET WELD SIZE SHALL EQUAL BASE METAL WHEN BASE METAL IS LESS THAN OR EQUAL TO 3/16".
- 4) WHEN THE THINNEST METAL IS 1/4" OR GREATER THE FILLET WELD SIZE SHALL BE 1/16" LESS THAN THE THINNEST METAL.

**UNLESS OTHERWISE SPECIFIED**

MACHINING TOLERANCES	FABRICATION TOLERANCES
FRACTIONS = ±1/64"	PREP ±1/16"
.X = ±0.30	AS FORMED ±1/16"
.XX = ±0.15	LOCATIONAL FIT ±1/8"
.XXX = ±0.05	CONSTRUCTION 0"-120" ±1/8"
ANGLES = ±1/2"	CONSTRUCTION 120"-18' ±1/4"
SURFACE FINISH 125 RMS	CONSTRUCTION 18' > ±1/2"
INSIDE CORNER RADII .010min./0.030max.	ANGULAR ±1"
BREAK ALL EDGES .005min./0.015max.	ANGULARITY BOLT HC ±1/2"
-ALL DIMENSIONS IN INCHES-	DIMENSIONING INCHES < 144" ±1/2"
	DIMENSIONING FEET > 144" ±1"
	-REMOVE ALL BURRS AND SHARP EDGES-

**BUSINESS PROPRIETARY**

THIS INFORMATION IS THE SOLE PROPERTY OF ELGIN SEPARATION SOLUTIONS AND IS NOT TO BE COPIED, DISCLOSED OR USED FOR ANY PURPOSE OTHER THAN THE PURPOSE FOR WHICH IT HAS BEEN SUBMITTED WITHOUT PRIOR WRITTEN PERMISSION BY ELGIN SEPARATION SOLUTIONS ©2015

IF IN DOUBT - ASK!

DO NOT SCALE DRAWING



**ELGIN SEPARATION SOLUTIONS**

TITLE TANGO-400-HD GA

10500 Cash Road  
STAFFORD, TEXAS 77477  
281-261-5778

DWN. KY	DATE: 10/11/21	SCALE:	DRAWING NO. 1 OF 2	REVISION
CHK'D. AT	DATE: 10/11/21	WEIGHT:	TANGO-400-HD	01
APP'D. ETB	DATE: 10/11/21			

01	KY	AT	INITIAL RELEASE	10/11/21
REV	BY	CHECKED	DESCRIPTION	DATE

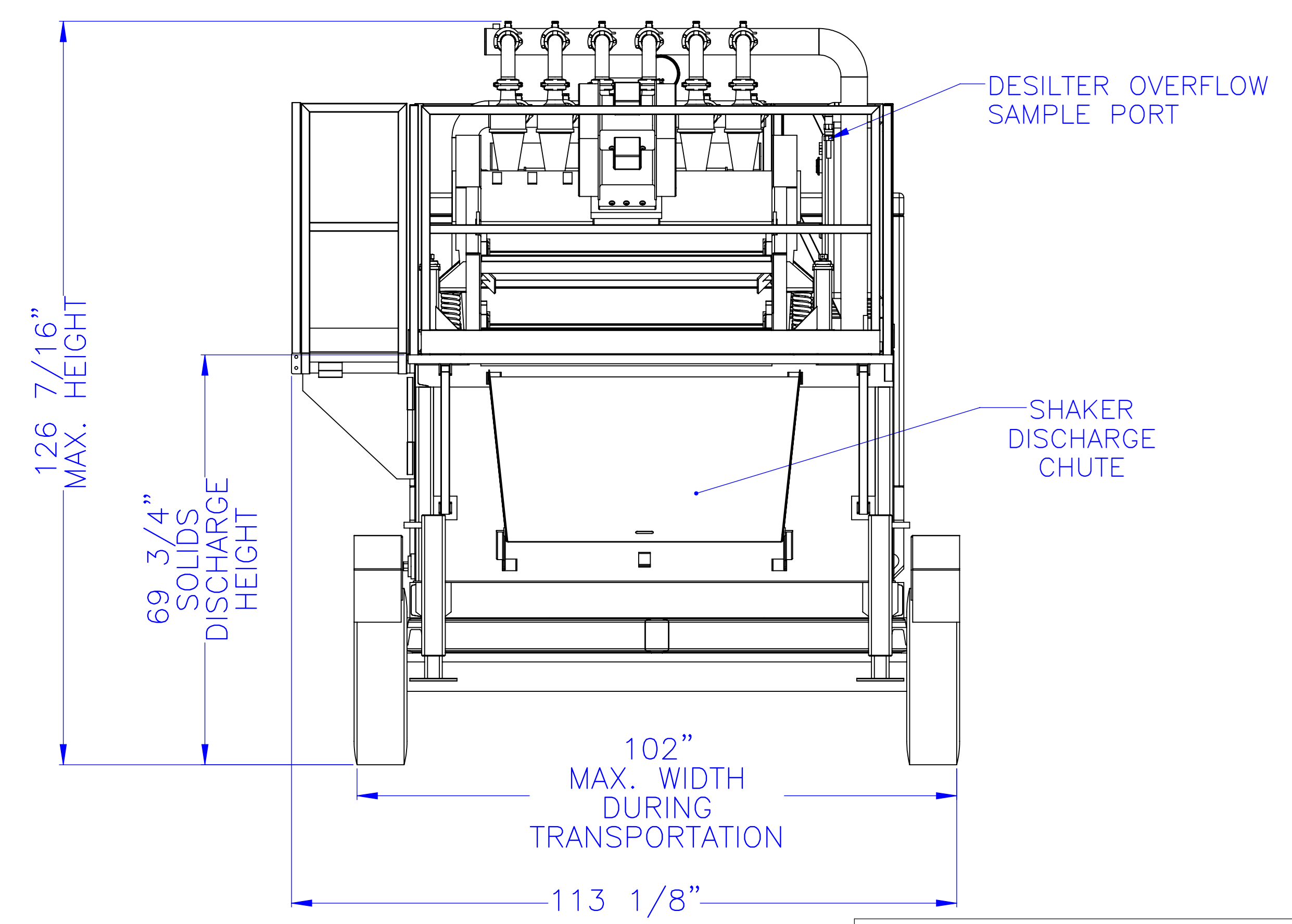
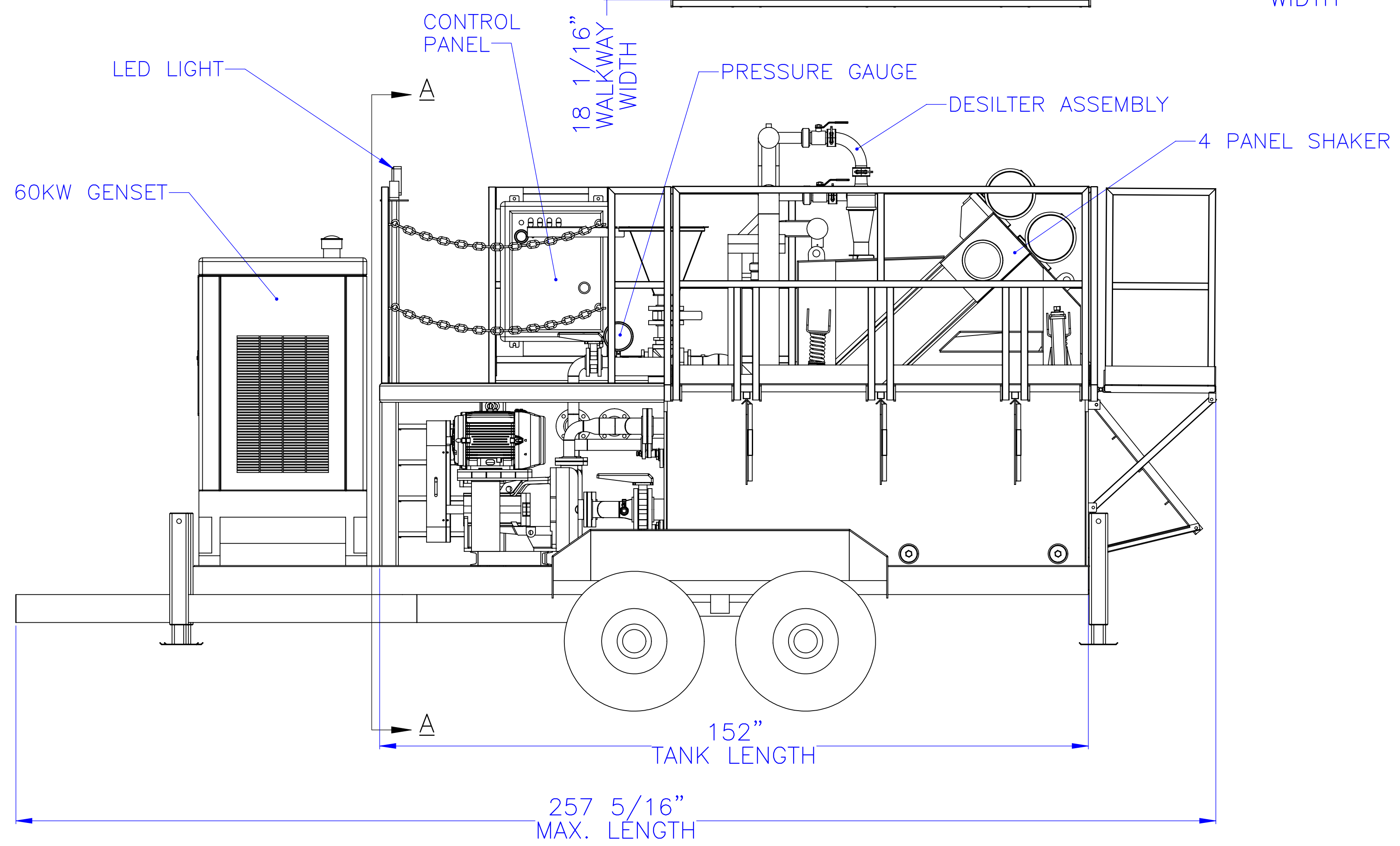
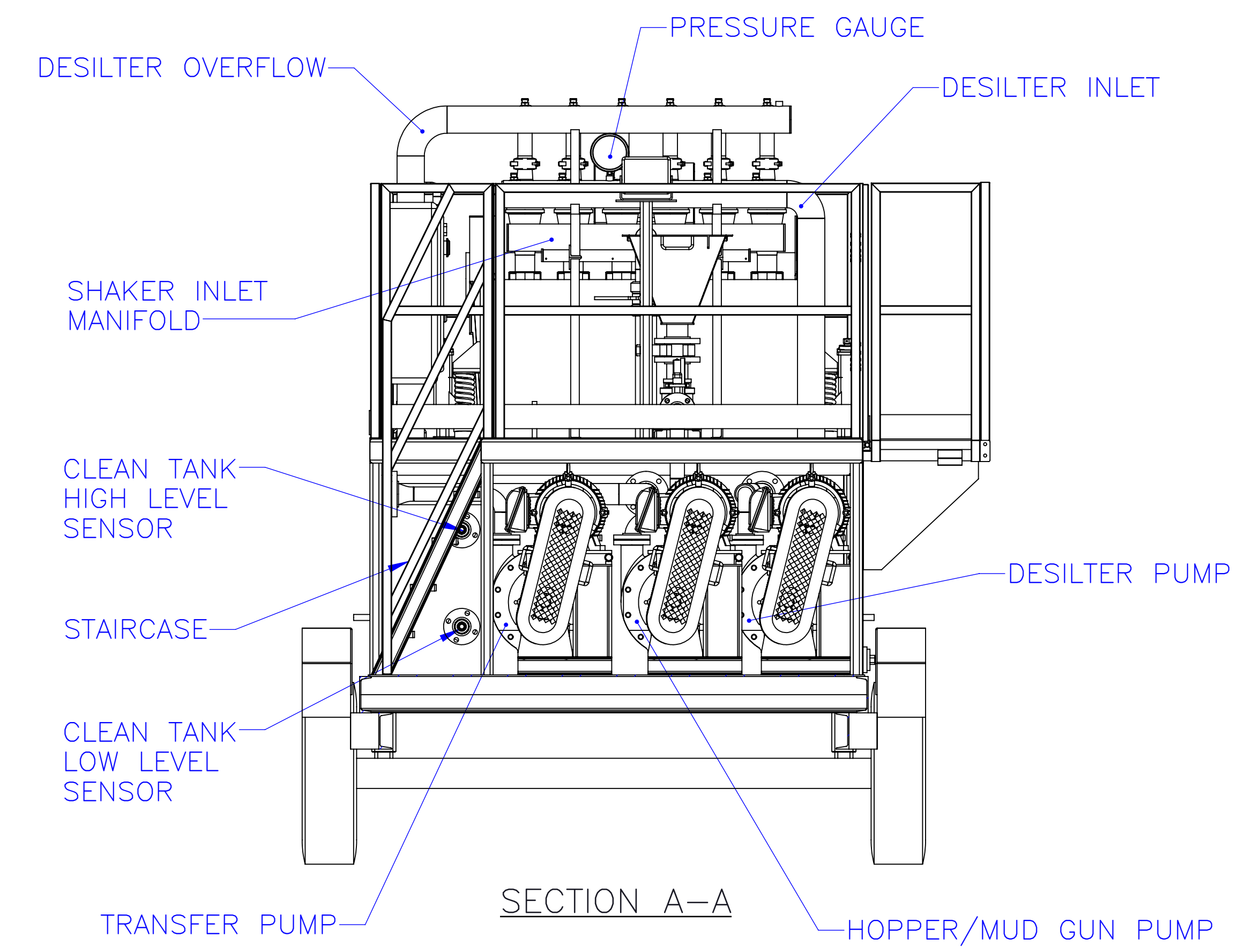
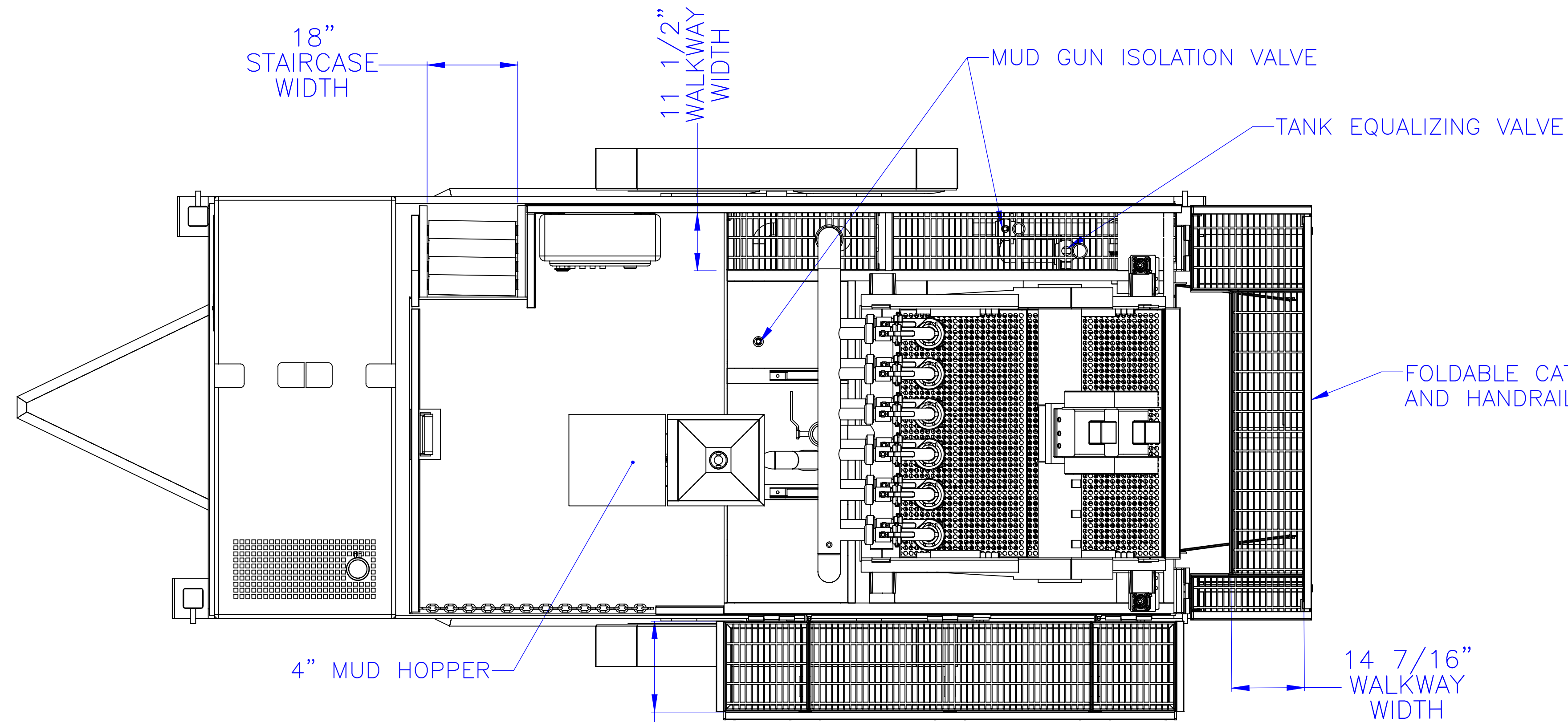

PART NUMBER TANGO-400-HD

**WELDING NOTE (UNLESS OTHERWISE NOTED)**

- 1) ALL WELDS SHALL BE CONTINUOUS.
- 2) ALL FILLET WELDS SHALL HAVE EQUAL LEGS.
- 3) FILLET WELD SIZE SHALL EQUAL BASE METAL WHEN BASE METAL IS LESS THAN OR EQUAL TO 3/16".
- 4) WHEN THE THINNEST METAL IS 1/4" OR GREATER THE FILLET WELD SIZE SHALL BE 1/16" LESS THAN THE THINNEST METAL.

**UNLESS OTHERWISE SPECIFIED**

MACHINING TOLERANCES	FABRICATION TOLERANCES
FRACTIONS = ±1/64"	PREP ±1/16"
.X = ±0.30	AS FORMED ±1/16"
.XX = ±0.15	LOCATIONAL FIT ±1/8"
.XXX = ±0.05	CONSTRUCTION 0°-120° ±1/8"
ANGLES = ±1/2°	CONSTRUCTION 120°-180° ±1/4"
	CONSTRUCTION 180° ±1/2"
	ANGULAR ±1°
SURFACE FINISH 125 RMS	ANGULARITY BOLT HC ±1/2°
INSIDE CORNER RADII .010min./0.030max.	DIMENSIONING INCHES < 144" ±1"
BREAK ALL EDGES .005min./0.015max.	DIMENSIONING FEET > 144" ±1/4"
-ALL DIMENSIONS IN INCHES-	-REMOVE ALL BURRS AND SHARP EDGES-

**BUSINESS PROPRIETARY**

THIS INFORMATION IS THE SOLE PROPERTY OF ELGIN SEPARATION SOLUTIONS AND IS NOT TO BE COPIED, DISCLOSED OR USED FOR ANY PURPOSE OTHER THAN THE PURPOSE FOR WHICH IT HAS BEEN SUBMITTED WITHOUT PRIOR WRITTEN PERMISSION BY ELGIN SEPARATION SOLUTIONS

©2015

IF IN DOUBT - ASK!

DO NOT SCALE DRAWING



<b>ELGIN SEPARATION SOLUTIONS</b>		10500 Cash Road STAFFORD, TEXAS 77477 281-261-5778	
TITLE TANGO-400-HD GA			
DWN. KY	DATE: 10/11/21	SCALE:	DRAWING NO. 2 OF 2
CHK'D. AT	DATE: 10/11/21	WEIGHT:	TANGO-400-HD
APP'D. ETB	DATE: 10/11/21		REVISION <b>01</b>