

COPRINOX

AGITATED VESSEL

Code n° RA 002 9999

Location ref: T1

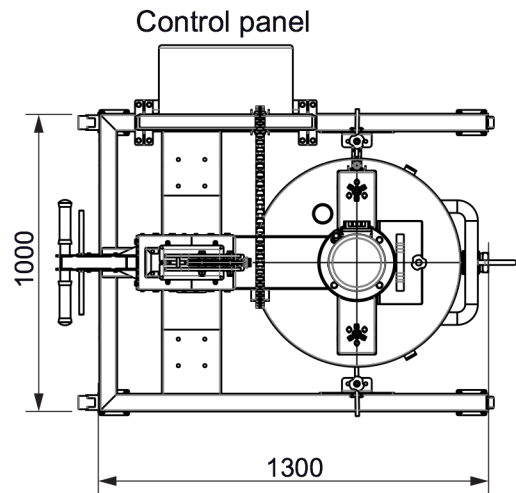
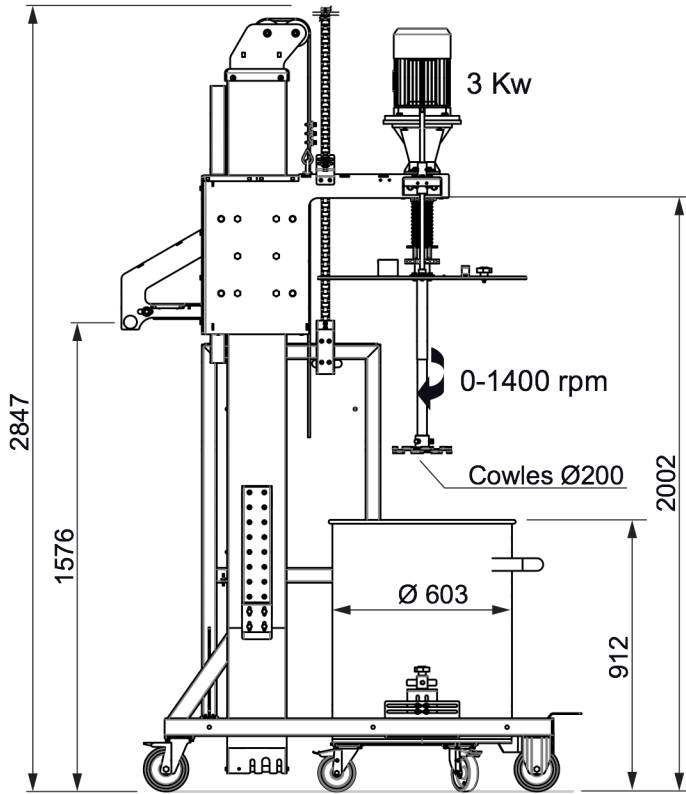

CAPACITY LITERS _____ 210 _____	SHELL SIDE	JACKET/COIL SIDE
Design Pressure KG/cm ²	ATM	
Design Temperature °C		
Material	AISI 304	
ANCC or ISPESL certification: _____ CE _____	NOZZLE DIMENSIONS	
Availability in stock n° _____ 01 _____ units	Pos	Service
MANUFACTURER: _____ COPRINOX _____	A	
<input type="checkbox"/> USED	B	
<input type="checkbox"/> USED RECONDITIONED	C	
<input checked="" type="checkbox"/> UNUSED	D	
WEIGHT (approx) Kg _____ 250 _____	E	
	NOTE	Model MIXUP200CW Control panel with inverter