

ITEM	QTY	FMC NO.	DESCRIPTION
1	1	A-513-3395	5HP 1750 MOTOR PARKER
2	1	A-8E-3357	PUMP P*PVC163DR2 PARKER
3	1	A-9E-4839	COUPLING LOVEJOY
4	1	A-8E-3359	RESEVOIR 20 GAL. PARKER
5	1	A-8E-3360	FILTER #12ATI0C PARKER
6	1	A-9E-4840	HOUSING
7	2	A-8E-3362	GAUGE #113.13-2.5-0-2000 LM WIKI
8	1	A-8E-3363	COMPENSATOR #786636 PARKER
9	2	A-8E-3365	SUBPLATE ADO1-SP-5-65-1 DAMAN
10	2	A-8E-3367	CYL. HYD. #3/4 CBB3LLTBAC#10 PARKER
11	1	A-8E-3227	CYL. HYD. #2 1/2 CBB3LLTBAC#13 PARKER
12	1	A-8E-3223	MOTOR HYD. #101-101B-007 CHAR-LYNN
13	2	A-8E-3244	VALVE-DIR. CONT. #DIVL4D PARKER
14	1	A-8E-3246	BOLT KIT # BK213 PARKER
15	1	A-8E-3247	VALVE-DECEL #MRIORG5001200 HERION
16	1	A-8E-3253	VALVE #PBDE-LBN-EBA SUN
17	1	A-8E-3254	VALVE #CBCA-LIN-EBA SUN
18	1	A-8E-3255	VALVE #NCCB-LAN-GBY SUN
19	1	A-8E-3225	VALVE #CBCA-LBN-YTA SUN
20	1	A-7E-3548	VALVE #N-600B PARKER
21	1	A-8E-3507	VALVE-3-WAY DIVLICY PARKER
22	38	A-8E-3387	FITTING 3/4-16 #20642-8-6 PARKER
23	4	A-8E-3384	FITTING #2503-10-8 PARKER
24	1	A-8E-3508	VALVE-CHECK/RELIEVE SUN
25	1	A-8E-3485	FITTING #0503-10-8 PARKER
26	13	A-8E-3391	FITTING #2503-6-8 PARKER
27	2	A-8E-3401	FITTING #033T-8-8 PARKER
28	4	A-8E-3385	FITTING #0103-4-8 PARKER
29	1	A-8E-3395	FITTING #2103-6-8 PARKER
30	1	A-8E-3396	FITTING #5703-6-8 PARKER
31	2	A-8E-3397	FITTING #0503-12-8 PARKER
32	4	A-8E-3398	FITTING #3903-B-B PARKER
33	720	A-9E-4827	HOSE 3/8 ID #421-6 PARKER
34	1	A-8E-3506	FITTING #2242-6-8S AEROGUIP
35	1	A-8E-3504	FITTING #2021-6-8S AEROGUIP
36	1	A-9E-4125	FITTING #2003-12-8B AEROGUIP
37	1	A-8E-3505	FITTING #2083-6-6S AEROGUIP
38	2	B-8E-3418	MANIFOLD
39	4	A-8E-3419	FITTING #2103-8-8 90° EL-PARCE
40	5	A-8E-3420	FITTING #0103-8-8 STRAIGHT-PARCE

A-8E-3364 HYD. POWER SUPPLY ASSY.

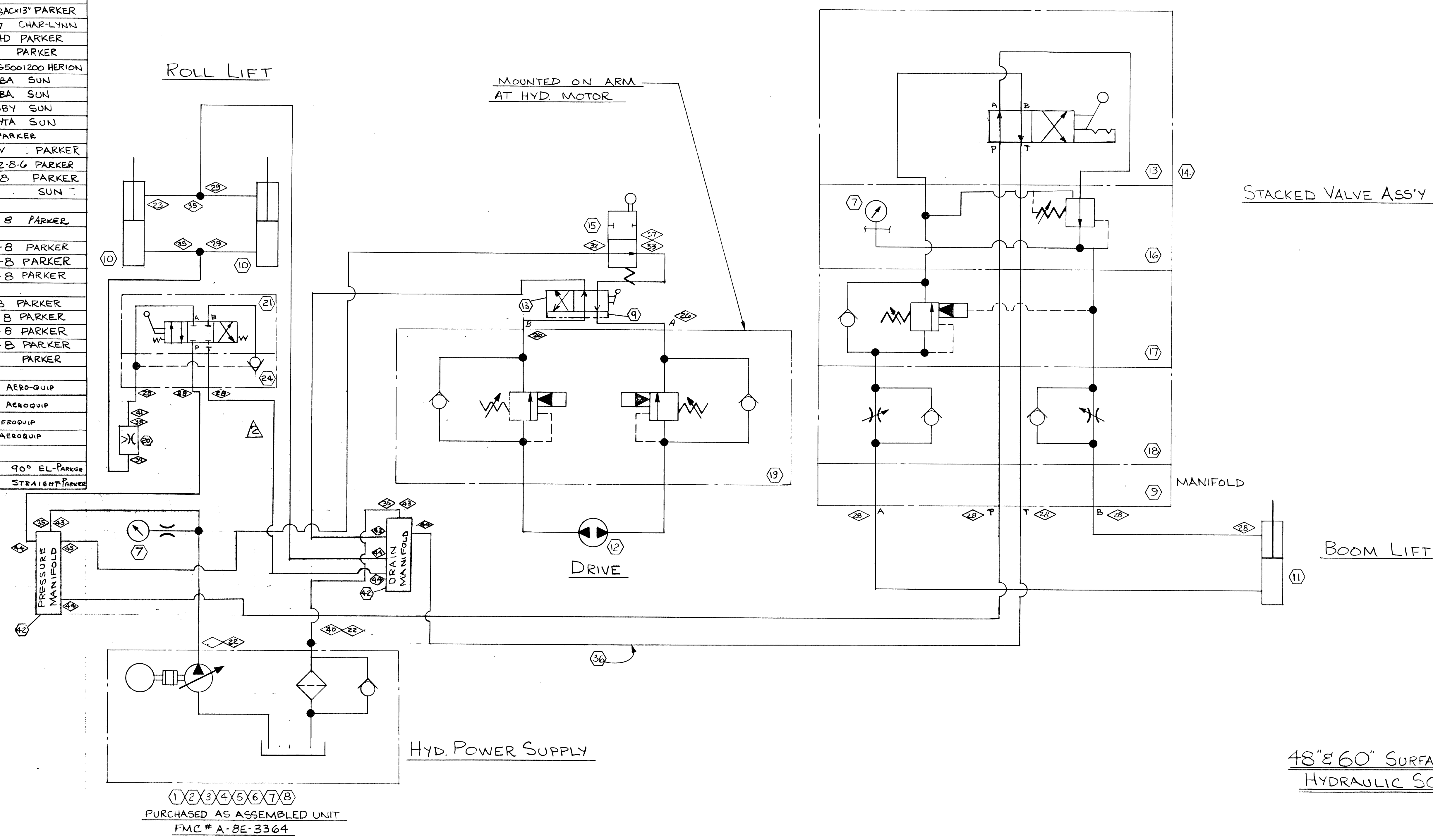

①②③④⑤⑥⑦⑧
PURCHASED AS ASSEMBLED UNIT
FMC # A-8E-3364

48" x 60" SURFACE DRIVEN UNWINDS
HYDRAULIC SCHEMATIC

SEE "D" 8E-1340 FOR FITTINGS LAYOUT

NO.		ECN	REVISIONS	BY	DATE
3			UPDATED PER SHOP ASSY.	BT	10-16-95
2			STANDARD (S) NEEDS VALVE A-8E-3413 ADD 3-WAY VALVE & CHECK RELIEF VALVE	BT	1-4-97
1			WAS 8E-3249	BT	2-20-88

THIRD ANGLE PROJECTION		<p>UNLESS OTHERWISE SPECIFIED</p> <p>DIMENSIONS ARE IN INCHES</p> <p>BREAK SHARP EDGES 0.020R</p> <p>TOLERANCES</p> <p>FRACTIONAL DIMENSIONS = ± 1/64</p> <p>DECIMAL DIMENSIONS = ± .005</p> <p>UNFINISHED CUTOFF, FABRICATION & SHEET METAL DIMENSIONS = ± 1/32</p> <p>ANGLES = ± 1/2°</p> <p>SURFACE ROUGHNESS = 125√</p> <p>PERPENDICULARITY ON FINISHED SURFACES = .005/1.000</p>	PROTECTIVE FINISH
			MATERIAL

<p>FMC FMC CORPORATION PACKAGING MACHINERY DIVISION GREEN BAY, WISCONSIN</p>	
TITLE SCHEMATIC - HYDRAULIC	
DWN BY L.I. N/EC	DATE 7-6-88
APPD	SCALE
DWG NO. 8E-1337	SH. OF