

**SPRINT
1310/1312**



**Entry-level models with
a claim to perfection**

Your partner for productivity and precision

HOLZ-HER[®]
Special Machines

SPRINT 1310/1312



Unit equipment

	1310	1312
Premilling station	–	●
Edge feed	●	●
Glue application system		
1906 M Cartridge for EVA and polyurethane glue	●	●
1905 Cartridge and granulate	○	○
1910 Glue roller	○	○
Pressure unit		
1912 with 2 pressure rollers	●	●
1912 with 2 pressure rollers pneumatic activation	○	○
1816 with 3 pressure rollers, including 2 conical back-up rollers	○	○
Trimming unit		
two motors, with chamfer trimming	●	●
Multifunctional unit		
1942 M for flush, radius and chamfer trimming	●	●
1942 M MOT2 with mot. adjustment	○	○
Scraper unit		
1929 Radius scraper	○	○
1929 MOT2 with mot. adjustment	○	○
Face scraper 1964	○	○
Buffing unit		
1940 for a perfect finish	○	○

- As standard
- Optional
- Not available

SPRINT 1310

For high-quality edge processing to perfect finishing. Additionally equipped with scraper unit, surface scraper and buffing unit.

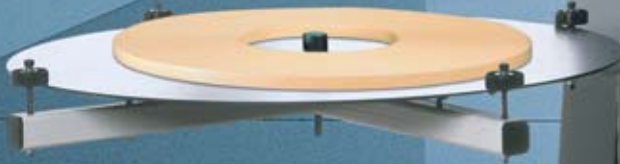

When economic efficiency and quality are the top priority

Perfect-looking joints is a key quality characteristic of fine furniture and in the professional interior fit-out sector. And it is only mechanised edge processing that can deliver the high level of quality demanded by the customer. Investment in an edge bander is thus essential, even for smaller businesses. The best possible solutions include the HOLZ-HER SPRINT models 1310 and 1312. What makes them special is the unique HOLZ-HER combination of high economic efficiency with the performance features otherwise only found in higher classes.



SPRINT 1312

The entry-level model 1310 supplemented by a premilling unit upstream of the glue application system. This eliminates even the finest tears in the surface layer of the panel, resulting in joints with a perfect appearance.



SPRINT 1310-1, 1312-1

An even greater output with the more powerful trimming unit 1918 with two 0.22 kW motors. Faster feed – 12,5 (8–18)m/min – greater throughput. The linear “self-drawing” cut ensures a precise tearfree trimming result. Basic equipment for SPRINT 1310-1 and 1312-1.

The power is at the centre: five communal units

The SPRINT 1310 and 1312 are equipped with five high-capacity core units:

- edging magazine
- glue application system
- pressure unit
- trimming unit
- multifunctional milling unit

Both machines can process rolled and solid-wood edges up to an edge thickness of 8 mm. Workpiece thickness 6 to 50 mm. Optional up to 60 mm.



The new design of the 1310 and 1312 edge banders will impress with a clear-cut geometrical use of forms and the operational benefits they offer. Outstanding stability is provided by the concept for stiffening of the series. The basic machine has been extended by 300 mm to provide for an optional face scraper. Accessibility is improved by greater height and an angled line guide. The patented glue application system guarantees a secure bond between edging and workpiece. This means that there is virtually no alternative in comparison with the SPRINT models 1310 and 1312.

HOLZ-HER[®]
Special Machines

SPRINT 1310/1312

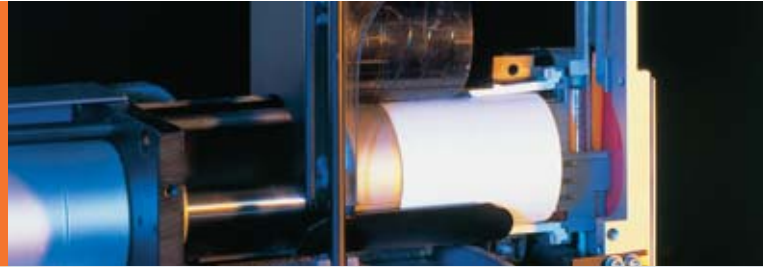

The new nozzle concept optimises gluing even further and provides for an extremely thin glued joint. The controlled application of glue takes place according to demand so that consumption is highly efficient. This results in low costs and no unnecessary waste. The closed heating system prevents any unpleasant odours. As the amount of glue currently required is only ever melted down, discolouration or burning are ruled out. When the stock of glue is running out, the control system issues a plain text message in good time: "Fill up glue".

Fast glue change

One particular advantage of the cartridge system is the option of quickly switching from EVA to polyurethane glue for efficient processing

or to change the colour of the glue. The cartridge is replaced. Time-consuming cleaning of the glue basin is no longer necessary.



Unique: the 1905 MULTI-SYSTEM

The first system for processing glue cartridges and glue granulate. This also applies to polyurethane glue. Here up to four cartridges can be used or 1.5 kg granulate added. The system is highly flexible and saves both time and energy in everyday usage. It is only the stack that is replaced – just add new glue and continue working.

Glue application system: For a secure bond

The performance of a glue application system depends on three factors: outstanding properties in terms of glue quality, short processing times and the resulting operating costs. The patented cartridge system 1905/1906 M from HOLZ-HER is a frontrunner in all three areas. It combines the high performance of a closed heating system with the outstanding benefits of nozzle technology. Here the melted glue is applied to the panel via nozzles at high pressure, filling the pores in the workpiece. The result is an extremely long-lasting extensive bond.



Ready to start in 3.5 minutes

As only the amount of glue actually required is melted down, the heating time is reduced to 3.5 minutes – twice as fast as other standard systems and offering an energy saving of up to 95%.

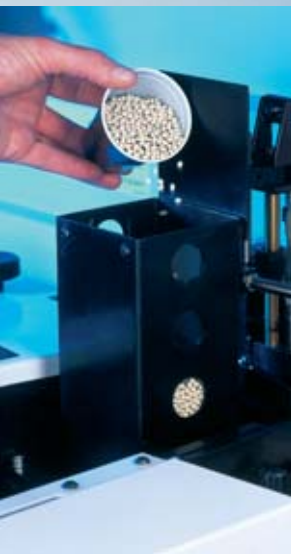

HOLZ-HER control: These features make it a winner

- Rotating and tilting control desk at eye level
- All units individually addressable
- Unit functions shown via plain text messages and with graphical support
- Clear central set-up of units and their axis settings via fine adjustment (depending on equipment)
- LED display for selection of units
- Large LCD display with plain text messages and graphics (optionally also in colour)
- Dustproof membrane keyboard with softkeys
- Program list with program names and numbers
- Large program memory (PCMCIA card)
- Acquisition of operating data and fault diagnosis integrated
- Individual data per program for edge length, quantity and processing time
- Integrated section control – section points are stored either on a general or program-specific basis
- Service messages in plain text
- Interval display for minimum workpiece spacing

Intuitive operation via graphics

The carefully thought-out ergonomic design of this machine series can also be seen in the new control desk for the Stored Program Control. High quality, clearly arranged, rotating and tilting, softkeys that feel good; it is a pleasure to work with the intelligent HOLZ-HER control concept, and economic efficiency is guaranteed. It is above all with small series that the minimisation of set-up times and high flexibility are of particular importance. With the HOLZ-HER control system fitted as standard in the SPRINT 1310 and 1312 the complete set-up procedure including fine adjustment can be carried out from the clearly arranged control desk on a centralised basis.



SPRINT 1310/1312

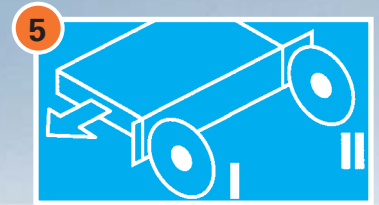
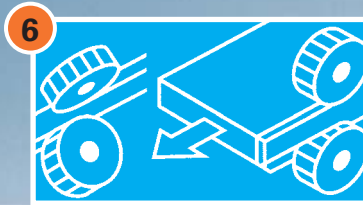

Multifunctional unit –

for flush, radius and chamfer trimming (2x0.6 KW). If required with motorised adjustment of tracer units for automatic changeover from radius to flat-surface trimming.

Trimming unit –

“self-drawing” linear cut for a clean trimming result including with thick solid-wood edges. Motor: 2x0.22 KW. Swivelling for chamfer trimming.

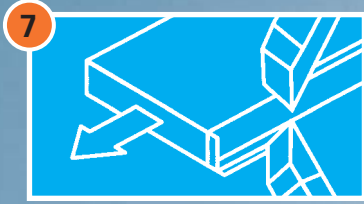

Scraper unit –

for perfect smoothing of radii and chamfers on synthetic edges. If required available with motorised adjustment.

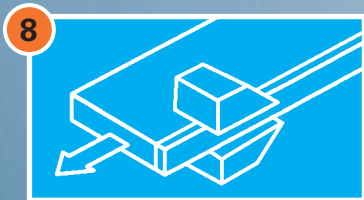

Surface scraper –

clean post-machining of surface – manual post-machining not required.

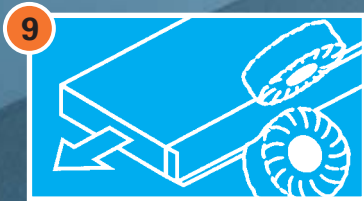

Buffing unit –

for perfect post-machining of edges and surfaces for impeccable finishing.

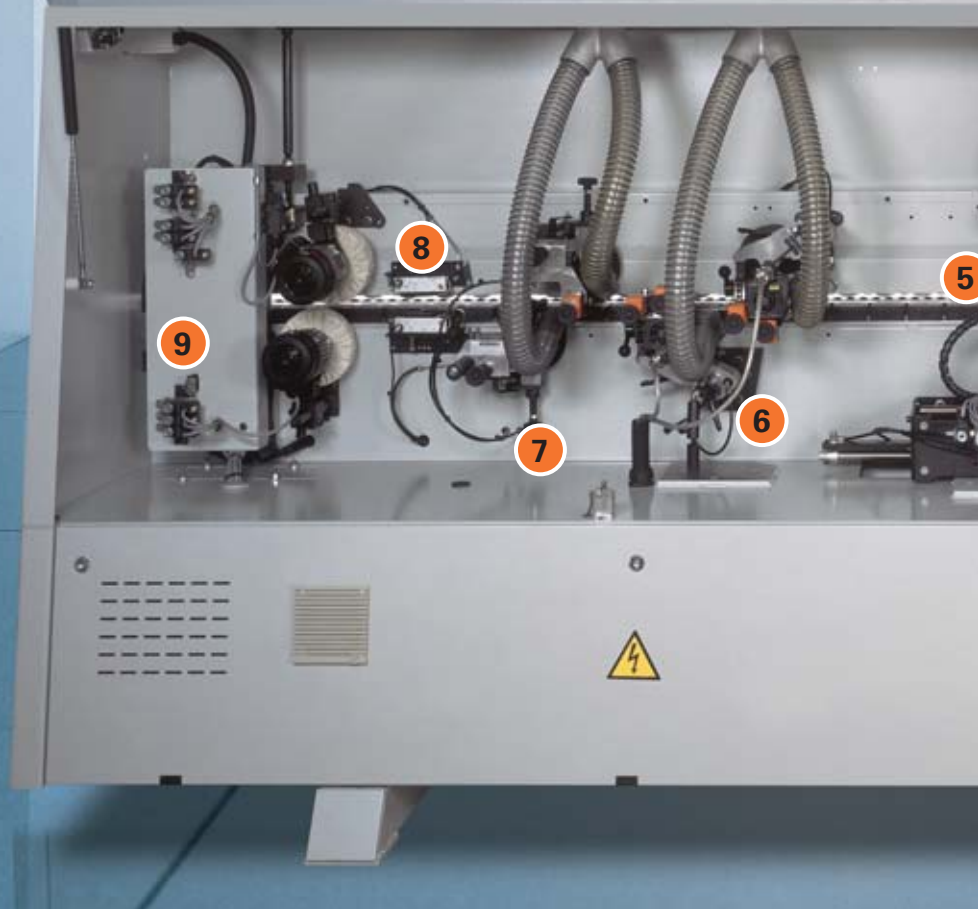

Powerful units – tailored to your requirements

The new design concept provides the individual units with plenty of room. They are clearly arranged and easily accessible, e.g. for tool change. All HOLZ-HER units offer superb performance and are designed and built for high continuous loads. Equipment variants are available for many units of the SPRINT 1310 and 1312 series to specifically tailor the edge bander to your requirements. If necessary, all units can be designed for tracer machining.

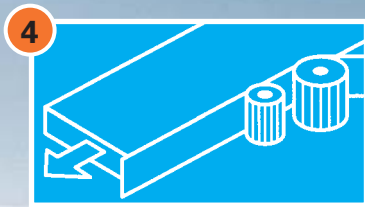

Pressure unit –

strong contact pressure for clean edge gluing. Pressure unit with pneumatic activation of first roller. If required additional pressure units with two conical back-up rollers.

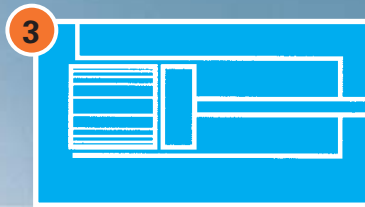

Glue application –

secure hold and clean joints. The basic equipment is the patented HOLZ-HER cartridge system for processing EVA and polyurethane glues.

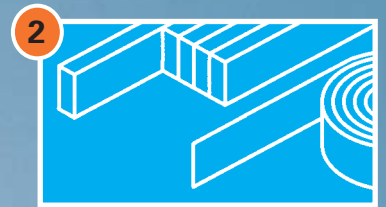

Edge feed –

fully automatic user-friendly feed of coiled and cut lengths. The coiled lengths are pretrimmed. The edging material is replaced in a matter of seconds without a tool.

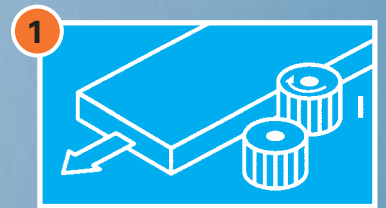

**Premilling station –
(2 x 2.0 KW)**

for milling edge surfaces of workpieces in panel form. The result: flat-faced glue surfaces without visible tears in the surface layer of the carrier material.

Photograph shows 1310 without premilling station, 1312 as standard with premilling station.

Central adjustment of the pressure bridge is possible with SPRINT models. Uniform drive is ensured by a powerful motor. The stable conveyor chain runs on precision guides and transports workpieces precisely and reliably through the machine with its light-grip surface pads.

SPRINT 1310/1312

Technical Data

	1310-1		1310-4		1312-1	
Machine dimensions						
Total length in mm <i>inch</i>	4376	172.28	4376	172,28	5291	208.31
Cutting dimensions – depending on equipment						
Workpiece thickness min./max. in mm <i>inch</i>	6/50	0.24/1.97	6/60*	0.24/2.36*	6/50	0.24/1.97
Edge band thickness depending on equipment in mm <i>inch</i>	0,4-8	0.02-0.31	0,4-15*	0.02-0.59*	0,4-8	0.02-0.31
Edge band height max. in mm <i>inch</i>	55	2.17	65*	2.56*	55	2.17
Edge band length strips min. in mm <i>inch</i>	350	13.78	350	13.78	350	13.78
Edge band projection/height						
Per side max in mm <i>inch</i>	3	0.12	3	0.12	3	0.12
Workpiece width min. in mm <i>inch</i>	60	2.36	60	2.36	60	2.36
Workpiece length max. in mm <i>inch</i>	180	7.09	180	7.09	180	7.09
Feed speed						
Feed speed standard/type 1 m/min <i>ft./min.</i>	12,5 (8-18)	41,01 (26,25-59,06)	12,5 (8-18)	41,01 (26,25-59,06)	12,5 (8-18)	41,01 (26,25-59,06)
Extraction						
Premilling unit in m ³ /h	–	–	–	–	900	900
Milling unit in m ³ /h	280	280	280	280	280	280
Scraper unit in m ³ /h	280	280	280	280	280	280
Static low pressure						
Premilling unit in Pa	–	–	–	–	1490	1490
Milling unit in Pa	1650	1650	1650	1650	1650	1650
Min. air speed in m/sec. <i>ft./sec.</i>	20	65.61	20	65.61	20	65.61
Premilling unit connection Ø in mm <i>inch</i>	–	–	–	–	125	4.92
Milling unit connection Ø in mm <i>inch</i>	70	2.76	70	2.76	70	2.76
Scraper connection Ø in mm <i>inch</i>	70	2.76	70	2.76	70	2.76
Compressed air						
Compressed air connection in bar	6	6	6	6	6	6

*) limited edge cross section

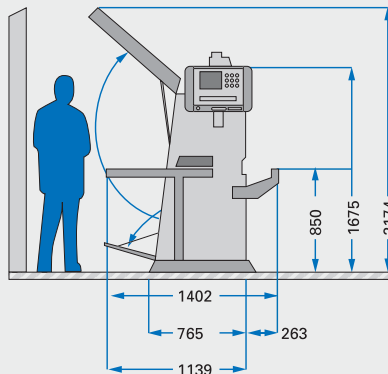

The technical data are given only as guidelines. We must reserve the right to make changes as our HOLZ-HER woodworking machines undergo continuous further development. For this reason illustrations are not binding. Some machines shown also include special equipment which does not form part of the standard scope of supply. Please find out about the exact scope of equipment from your HOLZ-HER dealer. Subject to alterations in design and equipment.

REICH

Spezialmaschinen GmbH
D-72608 Nürtingen

Tel.: +49 (0) 70 22 702-0
Fax: +49 (0) 70 22 702-101

www.holzher.de

Your authorised HOLZ-HER special machines dealer

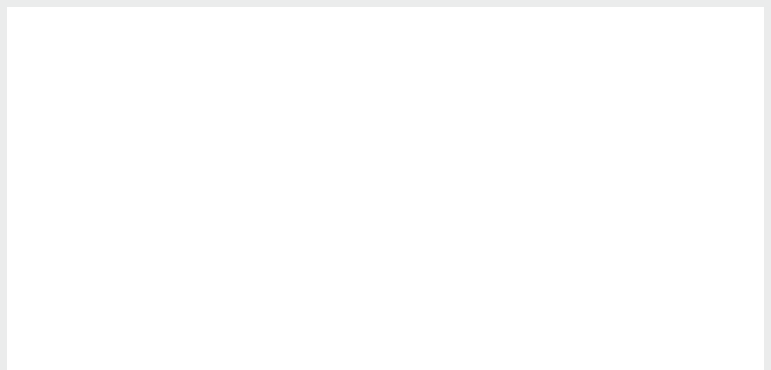

HOLZ-HER
Special Machines