

Selbstreinigender hermetischer Milchseparator HMRPX 718 HGV

Anwendung

Separierung, Standardisierung und Klärung von Heissmilch, Separierung von vorgereinigter Molke. Konstruiert für kontinuierlichen Betrieb und CIP-Reinigung.

Arbeitsweise

Der Separator hat folgende Konstruktionsmerkmale:

1. Hermetisch mit hoher hydraulischer Leistung. Die Milch wird von unten über einen feststehenden Anschlussstutzen und eine Hohlwelle in die Separatortrommel geleitet. Eine Axialdichtung am Einlauf verhindert jegliches Eindringen von Luft. Die langsame Beschleunigung der Milch vermeidet die Zerstörung der Milchfettkügelchen und steigert die Entrahmungseffektivität. Der Einlaufdruck sollte ausreichend hoch sein, um die Milch unter Druck durch den Separator zu den Ausläufen zu fördern. Magermilch und Rahm werden mit Hilfe von eingebauten Pumpen ausgetragen. Die Durchmesser der Pumpenräder können so gewählt werden, dass die für die anschließende Prozessausrüstung erforderlichen Auslaufdrücke optimal erreicht werden. Diese Konstruktion führt zu einer geringen mechanischen Belastung der Produkte sowie zu einem minimalen Energiebedarf. Die hohe hydraulische Leistung, ein typisches Merkmal der hermetisch geschlossenen selbstreinigenden Separatoren, wird durch den geringen Druckverlust im Separator erreicht.

2. Automatische Schlammaustragung. Schlamm, der sich im konischen Schlammsraum der Trommel ansammelt, wird in vorgewählten Zeitabständen automatisch durch kurzzeitiges Absenken des Schieberbodens (< 1 Sekunde) ausgetragen. Das Öffnen und Schliessen der Trommel geschieht mit Hilfe von Wasser, gesteuert durch ein Programmgerät. Die Trommel öffnet für einen so kurzen Zeitraum, dass nur eine kleine vorgewählte Menge ohne Unterbrechung des Zulaufes austreten kann. Während der chemischen Reinigung wird die Trommel so lange geöffnet, dass der erforderliche Inhalt austreten kann.

3. CIP-Reinigung. Die Maschine ist für CIP-Reinigung konstruiert und sollte in das automatische CIP-Reinigungssystem der Anlage eingegliedert werden. Während der Wasserspülphasen des Reinigungszyklus werden grosse Entleerungen durchgeführt, während bei den Reinigungsmittelphasen, zur Einsparung von Reinigungsmitteln, nur kleine Entleerungen erfolgen. Alle mit Milch in Berührung kommenden Teile des Separators sowie die Aussenseite der Trommel, die Innenseite der Gestellhaube und der Schlamm-auslass werden gründlich gereinigt, ohne dass manuelle Reinigungsarbeiten geleistet werden müssen. Ein extern angeordnetes System führt während der Reinigung der Maschine den Gleitringdichtungen Reinigungsflüssigkeit zu. Das gleiche System wird auch für die Spülung der Dichtungen mit Wasser während des Anlaufs, des Auslaufens und der Produktion benutzt.

4. Niedriger Geräuschpegel. Die Maschine wird in schallgedämpfter Ausführung geliefert. Der Geräuschpegel liegt bei entsprechender Installation unterhalb 80 dB(A).

Grundausrüstung

Werkstoffe. Alle mit dem Produkt in Berührung kommenden Teile sowie die Motorverkleidung und der Schlammzyklon sind aus nichtrostendem Stahl hergestellt. Der untere Gestellteil ist mit nichtrostendem Stahl verkleidet.

Standardausrüstung. Die Standardausrüstung umfasst Motor, Grundplatte, automatische Luftdruckbremse, Steuerwassermodul OWM, einen Zyklon zur Absorption der kinetischen Energie des ausgestossenen Schlamms sowie die aussen angeordneten Teile zur Reinigung und Spülung der Gleitringdichtungen.

Ein Ersatzteilsatz ist ebenfalls enthalten.

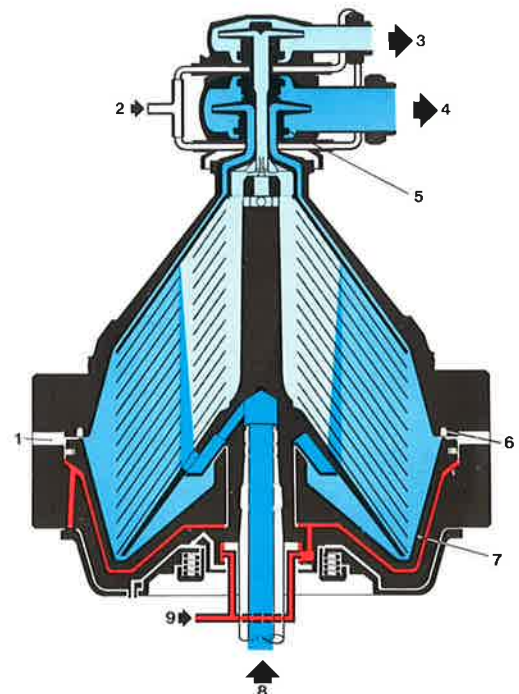

- | | |
|-----------------------------------|------------------------|
| 1. Schlamm-auslassöffnungen | 6. Dichtungsring |
| 2. Wasser/Reinigungsmittel-Zufuhr | 7. Schieberboden |
| 3. Rahmauslauf | 8. Milcheinlauf |
| 4. Magermilch-auslauf | 9. Steuerwasser-zulauf |
| 5. Magermilch-auslauf-dichtung | |

Selbstreinigender hermetischer Milchseparator HMRPX 718 HGV-74C

Technische Daten

Leistung. Heissmilchseparierung: 35.000 l/h.
Milchstandardisierung und Klärung: 50.000 l/h.
Molkeseparierung: 35.000 l/h.

Anschlüsse. Einlauf 63,5 mm, Magermilchauslauf 63,5 mm,
Rahmauslauf 38 mm. SMS-Verschraubungen.

Motor. 25 kW Drehstrommotor für Schweranlauf, 380/660 V
50 oder 60 Hz, dreiphasig, Wechselstrom. Andere Span-
nungen auf Anforderung. Der Motor treibt die Separatoren-
trommel direkt über ein Schneckenradgetriebe an.

Trommeldrehzahl. 4.150 UpM.

Schlammraum. 17,2 l

Wasserverbrauch. Steuerwasser: Zeitweiliger Durchfluss
von bis zu 1 l/s, max. 3 Sekunden, bei einem empfohlenen
Druck von 400 kPa (4 bar). Dies entspricht 0,5–1,0 l pro
Entleerung. Schlammraumspülwasser: 25 l pro Entleerung.
Gesamter Wasserverbrauch für die Kühlung der Gleitring-
dichtungen, des Getriebeöls, für Steuerwasser und der
Innenseite der Gestellhaube: ca. 250 l/h.

Luftverbrauch. Für pneumatische Bremse 600 kPa (6 bar).

Einlaufdruck. Max. 600 kPa (6 bar). Abhängig von der
Durchsatzleistung und dem erforderlichen Auslaufdruck.

Auslaufdruck. Bis zu 600 kPa (6 bar) bei Magermilch und
Rahm.

Hebevorrichtung für 15 kN (1.500 kg oder 1,5 Tonnen) ist
erforderlich.

Abmessungen (mm)

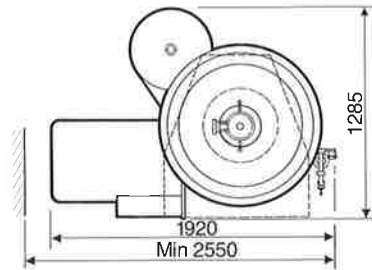
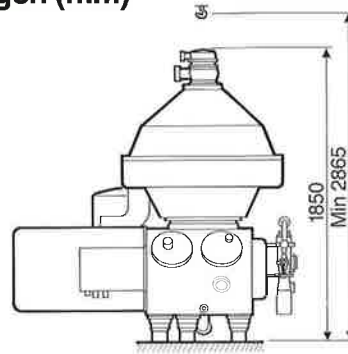

Versanddaten

	Grundausführung ohne Motor	Nur Motor
Nettogewicht, ca.	1.975 kg	360 kg
Bruttogewicht, ca.	2.350 kg	440 kg
Volumen, ca.	4,7 m ³	0,6 m ³

Zusatzrüstung (erforderlich für den Betrieb)

Pos. Nr.	Beschreibung	Nicht zu verwenden mit Pos. Nr.	Erfordert Pos. Nr.	Siehe PD Nr.
1	Werkzeugsatz (für je 3 Maschinen)			
3	Rahmdurchflussmesser	13, 14		
4	Durchflussregler			60687
16	Konstantdruckventil für Magermilchauslauf		18	60692
18	Programmsteuerung ALSEC			
23	Y/D Starter			
26	Zulaufventil SRC-SMS-63,5-20-20		18	

Sonderausrüstung

Pos. Nr.	Beschreibung	Nicht zu verwenden mit Pos. Nr.	Erfordert Pos. Nr.	Siehe PD Nr.
2	Zulaufmengenmesser			
13	Wiedervermischungsvorrichtung	3, 14		60688
14.1	Standardisierungsgerät, manuell	3, 13		60689
14.2	Dito, automatisch	3, 13		62073
24	Überstromauslöser			
28	Sonderersatzteile			

MWW MACHINERY WORLD



DAIRY CENTRIFUGES **From the Originator of Separation Equipment**

 **Tetra Pak**

OVLAĐAŃI (POČITAČ)

A centrifugal separator for every duty

Alfa Laval has developed, produced and installed dairy centrifuges for more than a century. The tradition continues with new cost-efficient models and high quality standards for a wide range of applications.

Milk clarification

The main purpose of this process is to remove impurities from milk. If process conditions are favourable, there will also be an efficient reduction in the amount of leucocytes and bacteria.

All centrifuges perform as clarifiers, but normally only machines with a high hydraulic capacity are used for this application. The clarifier can operate either with cold milk, below 8°C (46°F), or hot milk, 50 to 60°C (122 to 140°F). Its efficiency with smaller particles will increase with the temperature. There are no standards for the amount of impurities permitted in the milk, but standards for leucocyte and bacteria levels are common in many countries.

Centrifuge	Max. flowrate, l/h	Sediment space, l	Rated motor power, kW
DMRPX 407 SGP	10 000	4.1	11
DMRPX 510 SGD	20 000	8.8	18.5
DMRPX 610 HGD	25 000	6.6	18.5
DMRPX 413 SGV	30 000	15	18.5
DMRPX 714 HGV	35 000	12	22
DMRPX 618 HGV	45 000	21	37
DMRPX 517 SGV	50 000	25	37

Hot milk separation

The largest application for centrifuges in dairies is hot milk separation which was its original usage in the dairy industries. The objective is to separate the globular milk fat from the serum, the skimmilk. The separation process is normally incorporated into the pasteurization line and also combined with an ALFAST direct in-line fat standardization system for both milk and cream.

Separation normally takes place at 50 to 60°C (122 to 140°F). When using the Scania Method for quality cream production higher temperatures are however required.

The fat content of the cream discharged from the separator can be regulated to a level

between 20 and 70%. The model of pasteurizer normally sets the limits for variations in the cream flow. In rare cases a relation 1 to 3 has been achieved.

The skimming efficiency of hot milk separators has been improved, but mechanical treatment in the large scale milk industry has reduced the possibility of achieving as good results as previously. Today a 0.04% fat content in skimmilk is seldom attained. In a modern dairy figures like 0.05 – 0.07% are more common.

Centrifuge	Flowrate, l/h	Stand.	Rated motor power, kW
HMRPX 407 TGP	5 000	7 000	11
HMRPX 510 TGD	7 000	10 000	15
HMRPX 610 HGD	10 000	15 000	18.5
HMRPX 614 HGV	15 000	25 000	18.5
HMRPX 714 HGV	20 000	30 000	22
HMRPX 518 HGV	25 000	35 000	22
HMRPX 618 HGV	30 000	40 000	25
HMRPX 718 HGV	35 000	55 000	25



Whey clarification

To maintain optimum fat separation conditions during a long period of time the fines should be removed from the whey before it reaches the separator.

The most efficient way to reduce the fines is to install a centrifugal clarifier ahead of the whey separator. The interval between sediment discharges from the fat separator can then be as long as that for the milk. Flowrate, fines content and skimming efficiency are important parameters for the choice of clarifier.

Clarification takes place at the same temperature as separation, i.e. the vat temperature.

Centrifuge	Flow-rate, l/h	Sediment space, l	Rated motor power, kW
DMRPX 407 SGP	10 000	4.1	11
DMRPX 510 SGD	20 000	8.8	18.5
DMRPX 610 HGD	25 000	6.6	18.5
DMRPX 413 SGV	30 000	15	18.5
DMRPX 714 HGV	35 000	12	22
DMRPX 618 HGV	45 000	21	37
DMRPX 517 SGV	50 000	25	37

Whey separation

Whey contains small amounts of fat which vary between 0.15 and 0.40% and have to be removed before further processing.

The whey characteristics differ from those of milk in such a manner that the conditions for whey separation are more favourable. If the whey is pre-clarified, the skimming efficiency can be expected to be better than that achieved in milk separation.

Hermetic whey separators can also produce high-fat cream with a fat content higher than 30% and at temperatures below 35°C (95°F).

Centrifuge	Effective flowrate, l/h		Rated motor power, kW
	Pre-filtered	Pre-clarified	
HMRPX 407 TGP	4 000	5 000	11
HMRPX 510 TGD	6 000	7 000	15
HMRPX 610 HGD	9 000	11 000	18.5
WMRPX 614 HGV	13 500	16 500	18.5
WMRPX 714 HGV	*	22 000	22
WMRPX 518 HGV	22 500	27 500	22
WMRPX 618 HGV	27 000	33 000	25
WMRPX 718 HGV	*	38 000	25

* Recommended with pre-clarification only

Cold milk separation

Cold milk separation at 4 to 5°C (39 to 41°F) is practised when heating the milk is undesirable. The viscosity and characteristics of the cream at low temperatures preclude any other form except hermetic separation.

Owing to less favourable processing conditions, the skimming efficiency of a cold milk separator is lower than that of the corresponding hot milk type. The fat content in the skim milk can vary between 0.1 and 0.2% and the maximum fat content in the cream at 4°C (39°F) is normally 45%.

Small temperature increases or lower flowrates will improve the results. The cold milk separator can also be used for hot milk separation.

Centrifuge	Flowrate, l/h		Rated motor power, kW
	Skimming	Stand.	
CMRPX 714 HGV	10 000	20 000	22
CMRPX 518 HGV	15 000	25 000	22
CMRPX 618 HGV	20 000	30 000	25



Anhydrous milk fat

Anhydrous milk fat is a product obtained from *fresh* raw material and contains more than 99.8% milk fat. Butter oil is produced from raw material of a varying age and contains a minimum of 99.3% milk fat.

The milk fat is concentrated in several steps from approximately 4% to 40% to 75% to 99.5% and is then vacuum treated. The number of steps depends on whether the raw material is milk, cream or butter. Buttermilk is recirculated and re-separated to increase the yield. In the following table hot milk separation is disregarded and concentration starts from cream.

Line capacity kg oil/h	Pre- concentr.	Final concentr.	Buttermilk re-separation
2 000	HMRPX 614	AMRPX 610	HMRPX 510
5 000	HMRPX 618	AMRPX 714	HMRPX 614

For stored butter the following centrifuges can be used. Fresh butter still contains globular fat and requires a process similar to the one for cream.

Line capacity kg oil/h	Final concentration
2 000	AMRPX 610
5 000	AMRPX 614
8 000	AMRPX 714

Buttermilk separation

For separation purposes buttermilk derived from butter manufacture is classified either as sweet or sour. (Fresh sour and neutralized buttermilk is processed as sweet.) Experience has demonstrated that the maximum separation temperature for sweet buttermilk is 45°C (113°F) and 28 to 31°C (82 to 88°F) for sour buttermilk. Optimum results are 0.2 to 0.3% fat in the buttermilk after separation.

For the separation of sweet buttermilk use a standard hot milk separator at its nominal capacity.

Sour buttermilk contains unstable proteins and the choice of separator and flowrate is more difficult. As a general guideline use a whey or cold milk separator and process at half the nominal flowrate.

Bactofugation

The BACTOFUGE® is used for a general reduction of the amount of bacteria present in the milk. This process is most efficient for spores as they are relatively heavy. The bactofugation process is traditionally incorporated in the pretreatment of cheese milk. Today the BACTOFUGE is also used to improve the quality of powders, consumption milk and cream and to normalize the bacteria content in the milk prior to heat treatment.

The bactofugation temperature depends on the application. In most cases a temperature of 50 to 65°C (122 to 149°F) is chosen to reduce spores. The efficiency is stated as a *percentage reduction* of the incoming amount. Depending on the process arrangement and conditions, the efficiency normally varies between 98 and 99.5% for anaerobic spores.

Centrifuge	Flowrate, max, l/h	Rated motor power, kW
BMRPX 714 HGV	15 000	22
BBRPX 714 HGV	25 000	22
BMRPX 618 HGV	25 000	25
BBRPX 618 HGV	45 000	25

Quarg production

Quarg is a fresh cheese made from coagulated skimmed milk. The solids content in non-fat quarg can vary between 14 and 22% depending on local legislation.

Separation takes place at 32 to 42°C (90 to 108°F) after tempering at 60°C (140°F). (The traditional separation temperature is 28°C (82°F) and separation normally takes place immediately after fermentation.) Following separation around 0.4% of the whey proteins remain in the whey.

Efficiency is calculated in terms of total yield, kg milk/kg quarg. Reports mention yields between 3.7 and 4.2.

Centrifuge	Feed max, kg/h	Rated motor power, kW
QMRKX 517 SGV	10 000	37

CLEANING IN PLACE

GENERAL

High hygiene in connection with a good processing procedure is a necessity in all food industries today. The consumers make heavy demands upon the quality and the keeping quality of the food products. Mechanization and automation have made great progress and the cleaning procedures, previously mainly performed by manual work, have become an integrated part in modern processing. This holds true for the dairy industry as well.

The chosen methods of cleaning and disinfection of the processing equipment is of outmost importance. During processing, the milk is generally subjected to some kind of heating. The main constituents in the milk, protein-fat-lactose and mineral salts, are influenced by the heating or other treatment and precipitate on the treating surfaces. The created layer must be removed when cleaning the equipment in order to secure high grade products.

In that connection questions like:

- which are the constituents in the "dirt"?
- how much?
- in which state are the constituents?
- aiming at physical, chemical and/or biological cleaning?
- etc.

have to be put forward. The answers to these and similar questions will give cleaning times, temperatures, flow rates as well as detergents and sequences.

It is important that the cleaning methods are optimized in order to give approved results at lowest costs and load on sewage system and environment.

The check of the cleaning result must be looked upon as an important part of the cleaning work. This checking can be divided into an ocular inspection and a bacteriological check. Due to the automation, the processing lines are now less available for ocular inspection. That means that more intensive bacteriological checking, concentrated to strategic places in the processing line, e.g. sections with vacuum where risk for infection is greater, will substitute the ocular inspection. As a rule, the counting of coliform bacteria is used as an indicator of the cleaning result.

WATER QUALITY

Water is the primary factor of all cleaning. To be usable for cleaning purposes the following demands must be fulfilled:

1. Free from objectionable suspended matter
2. Free from objectionable taste, odour or colour
3. Not excessively hard
4. Low iron and manganese content
5. Devoid of pathogenesis and with a low total count of bacteria
6. Free from toxic substances

In most countries the Health Authorities require a certain degree of water quality for food purposes.

The following measures can be adopted in order to improve existing water of less good quality:

1. Sedimentation
2. Filtration
3. Chlorination
4. pH-control
5. Softening

The chemical quality, especially with regard to the hardness, must be carefully considered. The carbonate hardness, e.g. salts of calcium and magnesium, as well as the hardness of non-carbonate constituents in the water, such as sulphates and gypsum, partly make the detergent inactive. A further drawback is the precipitation of these carbonates on cleaned surfaces. Water with a high degree of hardness must therefore be softened.

Sometimes lower pH can be acceptable. That is when the cleaning cycle ends with slightly acidified rinse water in order to prevent bacterial growth. This acid solution also "passivates" the stainless surface somewhat.

SOME FACTS ABOUT DETERGENTS

In most cases water alone cannot clean objects. Its power to remove dirt and deposits is insufficient. Chemicals which increase the cleaning effect of the water must be added in order to obtain a satisfactory result. Sodium hydroxide (NaOH), also known as caustic soda, is a well-known detergent. It has been used in the dairy industry for a long time, mainly where dairy products have been heated. Cleaning of tanks and pipeline systems was previously performed apart from e.g. plate heat exchangers and often by means of weaker detergents. When the automatic Cleaning-In-Place method - CIP - was introduced, the detergent solution is distributed from a central detergent tank. An integrated cleaning procedure consequently needs a composed detergent, suitable for all cleaning purposes.

It is certainly not possible to produce one which is perfect for each special purpose. It is, however, possible to get well on the way by mixing adequately existing detergents of different characteristics.

A good detergent must have the following characteristics:

1. Strong emulsifying effect
2. Good wetting properties
3. Easy to rinse off
4. Keeps dirt suspended, also when diluted greatly
5. Prevent depositing of carbonates
6. Strong bactericidal effect
7. Low corrosiveness

ALKALI AS DETERGENT

The best way to dissolve protein is to treat it with alkali. (In narrow passages it might be better to start with acid. Alkali has a swelling effect on protein while acid results in contraction. See under "Acid Cleaning Solution"). The most suitable cleaning agent is sodium hydroxide. It is the strongest of the alkalis and only small quantities are needed to make the pH of the cleaning solution rise to the required level. In order to make the protein soluble within a reasonable time, cleaning with high pH, between 12 and 13, is needed. When it comes to attacking and removing dried-in or burnt-on rests of milk, the cleaning solution must have a softening or colloidal power. This power seems mostly to depend on the alkalinity: the higher the alkalinity the greater the power. The dissolving effect of sodium hydroxide upon albumin is good and its micro-bicidal effect is high.

In the Table below a comparison is made between sodium hydroxide (NaOH) and sodium carbonate (Na₂CO₃) concerning pH in solutions of varying strength.

%		0.25	0.5	1.0	2.0
NaOH	pH	12.5	12.8	13.0	13.3
Na ₂ CO ₃	pH	11.3	11.4	11.6	11.7

The Table shows that the pH value in the sodium carbonate solutions is not dependent on the concentration in the same way as the pH value in sodium hydroxide solutions. This is due to the buffering capacity of the sodium carbonate which also means that the cleaning ability is maintained in a superior way compared with solutions of sodium hydroxide. However, the sodium carbonate sometimes used is, not very suitable due to slow action in dissolving protein in combination with a poor bactericidal effect.

At high-temperatures, above 50°C, the sodium hydroxide partly attacks the fat and also easily hydrolyzes it into soluble soap. The power of alkaline detergents to attack and remove fatty deposits very likely has its explanation in that saponification first occurs and that the produced soap then attacks and emulgates the fat.

Alkali always forms the basic substance of a detergent and it is now supplemented with surface-tension reducing mediums, so called wetting agents, with power to emulsify the fat. They are also active in keeping freed dirt suspended in the detergent solution.

WETTING AGENTS AS A SUPPLEMENT

The surface tension is a factor which regulates the main part of all phenomena at the interface between fluid bodies and objects which are insoluble in each other. The main task of the wetting agent is to reduce this surface tension between water and fat so that the cleaning solution can wet and attack the fatty impurities. The effect of surface-active substances is explained by the fact that they fix a position in the surface layer between water and fat, their molecules being such that part of the molecule dissolves most easily in the fat and part of it in the water. In that way, connecting links are produced between the cleaning solution and the fatty substances. There are different types of wetting agents. The common property of all types is that one part of the molecule attracts the water - the hydrophilic group - and one part attracts the fatty substances - the hydrophobic group.

Depending on if the hydrophilic group has a positive charge, a negative charge or is neutral, one speaks about cation-active, anion-active or non-ionizing surface-active substances.

Wetting agents are active regardless of the hardness of the water, without giving precipitates, and they can be used in both acid and alkaline solutions. Too high concentration of the wetting agent requires longer rinsing time.

DISINFECTION

The term disinfection is used when the micro-organisms, not necessarily all of them, are destroyed by means of physical and chemical treatment. On the other hand, sterilization means complete extermination of the micro-organisms in a substrate created on the processing surfaces of equipment.

It is normally not a question of sterilization after a CIP cycle, but also then there is naturally an ambition to obtain as good results as possible.

Even if the cleaning has been well done, there will remain a number of bacteria, also on surfaces which are polished. The smallest remains of sugar and protein - particularly if colloiddally swelled products of protein remain - can cause bacterial growth.

DISINFECTION METHODS

There are different methods to be used for disinfection. They are:

1. Steam treatment
2. Hot-water treatment
3. Chlorination
4. Disinfection with non-chlorine agents

Disinfection by means of heat treatment is an excellent method. The temperature must, however, be high and combined with a sufficiently long contact time which the following Table shows (not valid for spore-forming bacteria).

80°C water kills bacteria within	5 - 15 sec.
----------------------------------	-------------

70°C water kills bacteria within about	30 sec.
--	---------

63°C water kills bacteria within	1 800 sec.
----------------------------------	------------

As a comparison, it can be added that the highest temperature you can keep your hands in is about 55°C.

Disinfection by means of direct steam can be left an open question, partly because it involves certain disadvantages in connection with burning-on of deposits and partly because of the difficulties to fit the steam disinfection into a system based upon the circulation principle. Hot-water disinfection is, on the other hand, fully in line with the principle and generally recommended in automatic CIP built by Alfa-Laval.

Steam and hot water are physical means of disinfection. There are many chemical means of disinfection. Two of these are chlorine, which is used to an ever increasing extent, and "Oxonía".

Most frequently used today is sodium hypochlorite (NaOCl) which has a very high bactericidal effect. In a disinfectant containing chlorine it is the quantity of active chlorine, i.e. chlorine in a free or active state, that is important for the disinfecting efficiency. The liberated oxygen acts as a strong oxidizing agent and the micro-organisms are destroyed by oxidation. 1 dl of sodium hypochlorite per 100 l of water is recommended when using chlorine in practice. The contact time should be minimum 5 minutes and maximum 15 minutes. The temperature of the chlorine solution must not exceed 25°C because of the corrosion risk. Should the rules regarding the use of chlorine solutions not be observed, this can result in serious damage to the stainless steel equipment, particularly plate heat exchangers. It is mostly the temperature and the overdosing of chlorine which cause damage.

The disadvantage of using chlorine as a disinfectant is mainly the corrosiveness, particularly at temperatures above 25°C , which has limited the use, at least in CIP systems. Within the food industry there is very often a demand for an ultimate disinfection with chlorine compound after the circulation of hot water. There is nothing which prevents doing so, provided everything is managed in the right way. As a rule it can be said that if chlorine is used immediately after cleaning and the processing line is not used, for instance overnight, the chlorine solution must be removed by means of rinsing with water or by means of compressed air, in order to decrease the risk of corrosion. The latter is mainly applicable to pipeline systems. The most efficient way in all disinfection work is considered to be disinfection just prior to the processing.

Except for Oxonia a number of non-chlorine disinfecting agents are available, such as quaternary ammonium compounds, iodophors, etc. Many of them are quite efficient from a disinfecting point of view. They have, however, drawbacks which make them less suitable. Iodophor is difficult to rinse away and might therefore cause a higher iodine content in the product. The presence of quaternary ammonium compounds can prohibit normal fermentation in milk products where fermentation is required and they have therefore become disreputed in dairy processing. Another disadvantage is precipitation created when milk and quaternary ammonium compounds are mixed.

The advantage of the non-chlorine disinfecting agents is the low corrosiveness.

CLEANING

GENERAL PROCEDURE FOR CLEANING OF MRPX SEPARATORS

One prerequisite for satisfactory separating efficiency is that the separator parts in contact with product have been perfectly cleaned before the feed is turned on.

Normally the separator is incorporated in a combined unit together with heat exchangers and further peripheral equipment, and due regard must be paid to this fact in determining the cleaning times and the volumes of detergent solution - even though the cleaning cycle is in principle the same for separator and heat exchanger. Two kinds of detergents should be used - acid solution and alkaline solution (lye).

The bowl must be emptied repeatedly during the various cleaning stages.

CHECK OF CLEANING

The bowl should be dismantled and the cleaning checked after the first operation with process liquid. Repeat the check after 3 - 4 days and after a further 14 days. If the results are favourable, the bowl can be left untouched until a minor overhaul is due. This should normally be made after about 3 months.

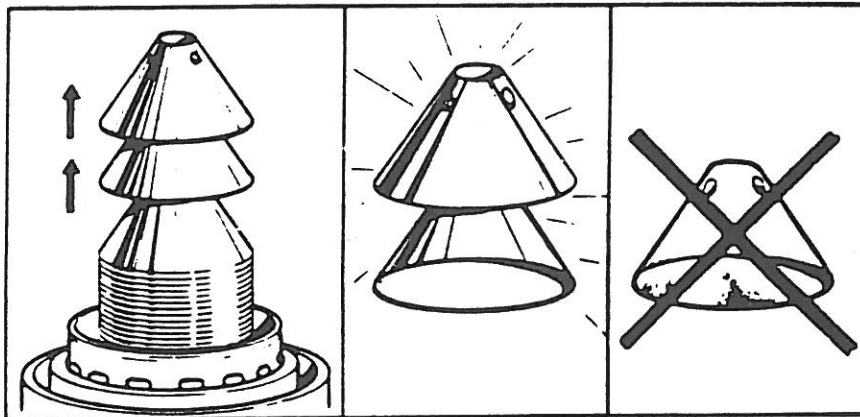

Inspect all discs. The upperside as well as the underside of every disc must be bright. Fatty discs and sediment residues on the discs indicate bad cleaning.

Note: A greyish film (but not containing milk residues) may also occur on the discs if the lye has been circulated after the acid. To remove the film an extra run with acid for about 10 minutes is recommended.

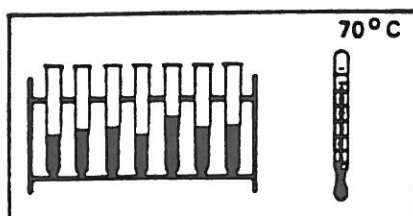

If the bowl turns out to be badly cleaned, check the temperature and concentrations of the acid and lye. Correct any deviations from the recommended values. Do not sample the concentration once only, but preferable several times.

CLEANING

Guiding values

Rinsing/washing time (minutes)	Type of discharge number of ejections		Liquid temperature °C
	Big disch.	Small disch.	
15 - 20	3 - 4		
20 - 30		2 - 3	70 ₊₃
10 - 15	2 - 3		
35 - 45		3 - 4	75 ₊₃
10 - 15	2 - 3		
6 - 10			90

1. Immediately after completion of the separation, pre-rinse with water.

It is important to pre-rinse as thoroughly as possible to prevent milk residues from mixing with subsequent detergent solution.

2. Circulate acid solution. The duration of circulation depends on the degree of contamination of the separator.

Note. In certain cases it may be better to start with lye solution, depending on milk quality, separating time separating temperature and water hardness.

3. Intermediate rinse.

4. Circulation of alkaline solution, the main ingredient of which is NaOH. Circulation time depends on degree of contamination, as for acid washing.

5. After-rinse with water.

6. Hot water disinfection shall be effected immediately prior to separation.

In disinfection with chlorous agents the temperature must in no circumstances exceed 25°C, as chlorine is highly corrosive at higher temperatures

For the ACID SOLUTION use nitric acid (HNO₃). Suitable concentration is 0.8 - 1% in solution. Find out the exact concentration of the acid purchased (normally 53%).

As for the ALKALINE SOLUTION a so-called detergent compound should be used comprising NaOH plus a complexing agent (for instance sodium polyphosphates Na₅P₃O₁₀, EDTA or NTA) with a nonionic wetting agent. The concentration of the alkaline solution should amount to 1 - 1.5% so that a pH-value of 12 to 13 is obtained.

For DISINFECTION with chlorous agents such as sodium hypochlorite (NaOCl) use maximum 1 dl per 100 l of water. As regards non-chlorous disinfectants follow strictly the instructions issued for such agents.