Table of contents		page
1.	Safety instructions	4
1.1	Correct usage.....	4
1.2	Explanation of symbols and signs.....	4
1.3	General working safety.....	5
1.4	Operation.....	5
1.5	Maintenance and repairs	6
1.6	Service and guarantee	6
2.	Preface	8
2.1	Please bear in mind the following points:	8
3.	Technical data	9
3.1	Machine Data	10
3.2	Energy consumption.....	10
3.3	Electric.....	11
3.4	Dimensional drawing UM/SK 150.....	12
3.5	Area of application and intended usage	12
3.6	Summary	13
4.	Set-up and starting	14
4.1	Rotational direction check	14
4.2	Function testing and test run	15
4.3	Starting-up the hydraulic system.....	16
5.	Operating Panel	17
5.1	The machine is controlled via the OP17.....	17
5.2	The keyboard of the OP 17	18
5.3	Information Text	22
5.4	Manual operation and input of nominal values.....	23
5.5	Automatic operation, Program and Charge selection, Start program.....	24
5.6	Program editing	26
6.	Operating the machine	28
6.1	Implement fitting	28
6.2	Loading the machine.	28
6.3	Mechanical and thermal product treatment.	29
6.4	Emptying the machine.....	30

Table of contents		page
7.	Daily cleaning and maintenance	31
7.1	Cleaning procedure	31
7.2	Maintenance work for 8 hour operation Maintenance work.....	32
8.	Machine description	34
8.1	Motors	34
8.2	Working inserts.....	35
8.3	Container	36
8.4	Safety features	38
8.5	Hydraulic unit.....	39
8.6	Pneumatic	40
8.7	Vacuum system.....	40
8.8	Functions of the steam supply unit.....	41
8.9	Water measuring device.....	42
8.10	Electronic equipment.....	42
9.	Fault repair	45
9.1	Faults in the drive motors	45
9.2	Faults in the hydraulic system.....	47
9.3	Faults at the vacuum pump	48
9.4	Faults in the electronic equipment.....	48
10.	Maintenance	49
10.1	Shapening the blades	49
10.2	Changing the seals.....	49
10.3	Regreasing the seals.....	53
10.4	Changing the lubricant of the mixing baffle gear	53
10.5	Maintenance of the hydraulic system.....	54
10.6	Recommissioning of the hydraulic system	54
10.7	Charging elevator	55
11.	Cleaning and disinfection	57
11.1	Stages of the cleaning and disinfection process	57
11.2	Disinfection	58
12.	Replacement and spare parts	60
12.1	Steam Pressure Table.....	61
12.2	List of assembly parts K 729.888	63
12.3	Hydraulic motors.....	66

12.4	Working Inserts.....	67
12.5	Discharge valve DN 65.....	68
12.6	Steam nozzle.....	70
12.7	Steam Trap - BP 23-3/4“,	71
12.8	Pressure transducer, type 4 AP-30	72
12.9	Hydraulic	82
12.10	Safety valve Series - 96.....	83
12.11	Safety valve type 718 - DN 40/50 0.1 bar.....	86
12.12	CP Valve terminal.....	91
12.13	Pneumatic filter regulateur LFR.....	98
12.14	Greasing pump.....	100
13.	List of the supplied documents from other companies	101
14.	Serviceadressen / Service addresses / Adresse du SAV.....	102
	Index	103

1. Safety instructions

STEPHAN machines are constructed for effective and safe use in the food and processing industry.

Conditions for the successful and safe operation of these machines are that:

- The machine is installed and commissioned only by appropriately trained personnel.
- The enclosed operation and maintenance instructions for the machine are followed exactly and maintained under all circumstances.
- Any person working with the machine should be thoroughly acquainted with the health and safety instructions.

1.1 Correct usage

· STEPHAN machines are intended for mechanical and industrial manufacture of products according to the procedures indicated and the specifications detailed for the machine and peripheral equipment supplied.

the following are not permitted:

- Operation and maintenance of the machine by unauthorised and not properly trained personnel.
- Inappropriate or improper use of the machine.
- Alteration of safety devices such as switches, locks, covers, guards, seals etc., or making them inoperative.
- Contravention of local safety and accident prevention regulations.

1.2 Explanation of symbols and signs

A number of signs are used in these operating instructions which must be observed under all circumstances in order to avoid risks to personnel and machines.

These signs have the following symbols:



DANGER
Sign which, when ignored, can lead to injury.



WARNING
Sign which, when ignored, can lead to damage to the machine.



NOTE
Notes and advice on working with the machine.

1.3 General working safety

Improper operation of the machine can lead to personal injury, damage to the machine and interruptions to the production process.

The management responsible must therefore ensure that operating personnel are properly trained and that only qualified and authorised personnel work on machine.



SAFETY LOCKING DEVICES

Mechanical and electrical safety devices located on the cover and in the discharging and emptying area prevent anyone from reaching into the machine while it is running. These safety devices must under no circumstances be made inoperative.



OILS, LUBRICANTS AND COOLANTS

Some of these agents endanger personal health and the environment. Only materials recognised as being physiologically safe should be used. Selection and use of these materials depends entirely on the management, although STEPHAN can make recommendations with respect to the materials used.



PRESSURE VESSEL REGULATIONS

If pressure vessels are installed, they are subject to regular inspections according to the pressure vessel regulations. If necessary, the vessel may need to be tested in the location where the machine is to be installed. All inspection certificates must be stored carefully. All working and inspection instructions in the pressure vessel regulations must be observed.



SAFETY VALVE

If the STEPHAN machine works with overpressure, the safety valve is protected in the works so that the permissible pressure cannot be exceeded. The valve is fitted with a lead seal so that the release pressure cannot be adjusted. Manipulating the valve can lead to fatal injuries. Removal of the lead seal also invalidates the guarantee. Material drained from the safety valve must be disposed of properly and safely.



SAFETY AWARENESS

- Management must ensure that operating and maintenance personnel are thoroughly acquainted with all safety instructions and that all safety instructions are actually observed. The operating instructions should be readily available for reference in the workplace.
- All working procedures which reduce safety at the machine must be avoided.
- Operators are obliged to announce at once every alteration to the machine which reduces its safety.
- The machine's safety can be reduced by:
 - * reconfiguration or alteration of the machine
 - * use of accessories other than those provided by STEPHAN- use of non-original replacement and wearing parts

1.4 Operation

Operators must be thoroughly trained in handling the machine and its processes.



CONCEALED KNIVES, CUTTING RINGS, FEED SCREWS, ETC.

Do not reach into full or partially full machine bowls or funnels, as there is risk of injury from concealed sharp-edged cutting tools and machine parts.

**TECHNICAL LIMITING VALUES**

Observe the limiting values for the technical machine data specified.

1.5 Maintenance and repairs

All maintenance and repair work may only be carried out by specially trained personnel..

**PLACING THE MACHINE OUT OF OPERATION**

- Switch off the main switch before maintenance and repair work to prevent it from being switched on inadvertently. This applies to all work on the switch cabinet and peripheral units.
- For steam installations the steam supply must be switched off and must be secured before re-starting. The machine and all pipelines must be depressurised.
- For hydraulic systems with an accumulator the system must be depressurised at the accumulator release valve.
- For pneumatic systems, the system must be depressurised and the stop valve closed.

**ELECTRIC SYSTEMS**

All electrical work must only be carried out by qualified electricians. The general and specific accident prevention regulations must be observed during electrical repair work.

**SAFETY DEVICES**

When dismantling safety devices for repair and maintenance work, the machine must be placed out of operation. The safety devices must be connected again immediately after completion of repair and maintenance work and checked for perfect operation.

**COMMISSIONING**

The operation of the safety devices must be checked before commissioning the machine.



It should be checked that the work tools are properly attached and that there are no foreign bodies in the machine, as loose parts in the machine can damage the work tools and motor shaft

**MOTOR PROTECTION IP 54 AND SWITCH CABINET PROTECTION IP54**

Washing the motor or switch cabinet with pressurised water or cleaning agent is not permitted.

1.6 Service and guarantee

**INVALIDATION OF GUARANTEE STEPHAN**

will accept no responsibility or guarantee claims for damage caused by:

- not observing the operating instructions,
- improper operation and maintenance of the machine and its peripheral equipment,
- technical and functional modifications carried out without consulting STEPHAN,
- use of parts other than original STEPHAN parts and accessories,
- disconnecting, dismantling or otherwise making safety devices inoperative.



REPLACEMENT PARTS

A stock of the most important replacement and wearing parts at the machine's location is important for its continual operation.



ORDERING REPLACEMENT PARTS

STEPHAN require the following information to process replacement parts orders:

- machine type from the cover of the operating instructions
- machine number from the machine type plate[e.g. K 720.000]
- order number in the replacement parts list in the operating instructions

This information avoids the need for any further questions from our Service Department and speeds up delivery.

We will be pleased to assist you with any questions on your machine

A. Stephan und Söhne GmbH & Co.
Serviceabteilung Stephanplatz 2 31789 Hameln

Telephon: 05151/5830 Fax: 05151/583110

Email: Vertrieb@stephan-germany.com Service@stephan-germany.com

2. Preface

The UM/SK 150 is a robust and durable multipurpose machine for the food production industry and food production technology, that is to say, this machine type may be used in almost all areas of food production, depending on configuration.

The vast number of available equipment allows many different variants. For this reason, we are not able to discuss your particular application in this manual.

We will, however, describe the basic machine and the available equipment in this operating manual.

Our technical advisors will recommend to you the most economic equipment for your product.

Those described variants which are not part of your machine have not been ordered and / or are not required for your product.

Should you have questions about your machine or the equipment which are not answered by this operating manual, or wish to enquire about the manufacture of a particular product, please get in touch with one of our technical advisors for your technical area:

or get in touch with one of our dealers.

2.1 Please bear in mind the following points:

This operating manual is intended to be read, understood and followed in every detail by those who are responsible for, and work with, the UM/SK 150

In particular, the general safety precautions on the colored pages at the front should be observed.

The complete documentation should always be kept at the place of installation of the UM/SK 150.

Only with full knowledge of the operating manual can mistakes of the multipurpose machine be prevented and a trouble-free operation guaranteed. Thus it is most important that the responsible persons are really familiar with this operating manual.

Please read these operating instructions through thoroughly before starting the machine, as we accept no liability for damage and operating errors which result from the non-observation of these operating instructions.

If, however, problems should ever arise, please get in touch with our customer service and spares department or with one of our dealers, who will gladly assist you (see address list on last page).

These operating instructions apply only to the product range UM/SK 150



The equipment was not inspected; for this reason, the pressure vessel has to be inspected at place of installation before it is taken into operation. Furthermore, we point out that the operator has to observe the working and inspection instruction of the regulations for pressure vessels (Regulation for pressure vessels §§ 8, 9, 10, 12, 31 and annex II, 12 and the valid national regulations of pressure vessels)

3. Technical data

Machine-type UM/SK 150

Customer

Comm.-no. K 729.888

Wiring-diagram-no.

Year of construction 2003

3.1 Machine Data

Bowl capacity (to bowl rim)	l	approx. 150
Load size (depending on product)	l	max. 100
Machine weight (net)	kg	1190
Max. permissible operating vacuum/excess pressure in bowl	bar / PSI	-1.0 / 0.0 -14.22 / 0.0-1.0 / 0.8 / -14.22 / 11.38
Max. permissible operating temperature in bowl	°C / °F	95 / 203 110 / 230
Max. permissible operating excess pressure, double shell	bar / PSI	2 / 28.44
Max. permissible operating temperature, double shell	°C / °F	133/ 271
Max. permissible direct steam pressure	bar / PSI	4.0 / 57.0
Max. permissible direct water pressure	bar / PSI	6.0 / 80.0
Max. permissible water pressure on the double jacket	bar / PSI	6 / 85
Max. permissible pressure, pneumatic systems	bar / PSI	8.0 / 114.0

Values for steam connection:

Steam consumption	kg/h	240
Steam prepressure	bar PSI	6-8 85 -114
Steam pressure behind the pressure regulator of the double jacket	bar PSI	2 - 3.5 28 - 50
Size of steam connection	DN	40

3.2 Energy consumption

Main motor n = 1500/3000 min ⁻¹	kW	29/33
Mixing baffle n = 24 min ⁻¹	kW	1.5

Vacuum pump	kW	0.75
Steam-Steam nozzles	l/h	approx. 240

3.3 Electric

Supply voltage / frequency	V / Hz	380 / 50
Control voltage	V	24 DC
Fuse protection at 440 V (slow-blow)	A	140

3.4 Dimensional drawing UM/SK 150

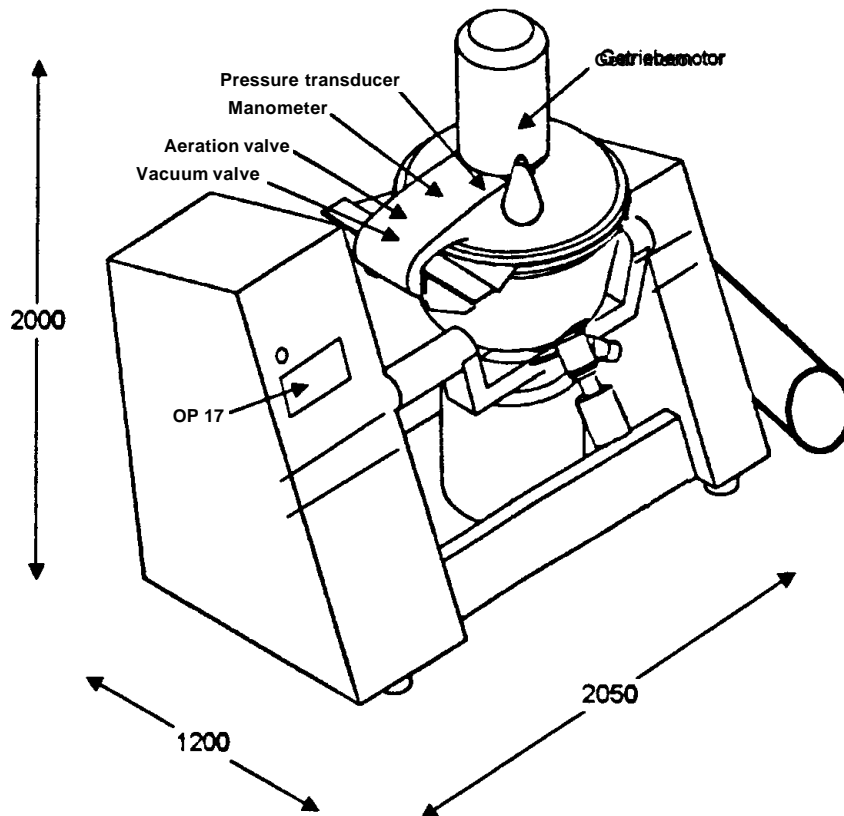

3.5 Area of application and intended usage

The UM/SK 150 is exclusively designed for the mixing, chopping, cutting, slicing, kneading and heat treatment of food products.

The Motor performance and the Implements must be compatible with the process and the product to be processed; the technical limit values of the machine should not be exceeded. (See " Machine Data" on page 10.)



Any other application of the machine is illegitimate. The manufacturer accepts no liability for any damage resulting therefrom.

3.6 Summary

The UM/SK 150 is a multipurpose machine for the manufacture of food products. It combines high performance with attractive design in the most compact form. It conforms to the most modern hygiene regulations.

All parts coming into contact with the product consist of non-rust stainless steel or other physiologically harmless materials.

The process container with the direct-driven implements is swivel-mounted on the machine base; bowl tipping and lid opening are performed hydraulically.



All peripheral elements (hydraulics, vacuum pump, power supply) are integrated in the machine base.

The following machine functions are available:

Loading	manually via opened lid
	automatically via measuring valve by evacuation or pumping
Processes	Mixing, chopping, slicing, cutting, emulsifying, kneading
	De-aerating by vacuum system
Emptying	manually via opened lid by tipping the container
	automatically via emptying valve
Control	manually via the OP control panel and the keyboard
	automatically by programmed control

4. Set-up and starting

The set-up, installation and starting of the UM/SK 150 will be carried out by our installation engineers or advisors, who should be provided with the necessary labor and lifting gear by the customer, free of charge.

What to do first..	...and then carry out and double check!
Due to its own weight and low-vibration operation, the multi-purpose machine may be installed without additional fastening. The adjustable rubber feet of the UM/SK 150 enable compensation for slightly uneven floors.	However, it requires a firm surface to stand on.
Before starting up, you should check that the supply voltage conforms to the operating voltage specified on the UM/SK 150 rating plate. The stipulated fuse protection must be provided.	 All electrical work is only to be carried out by a qualified electrician.
Connect the feed pipes.	 Check pipes for leaks. Check the steam piping particularly carefully.
Remove all loose parts from the machine.	 Loose parts flying about in the machine may damage the implements and the motor shaft.

4.1 Rotational direction check

The direction of rotation check has already been carried out during test running before the delivery of the UM/SK 150. Should, on new installation, a drive have a direction of rotation different to that given in the table below, the polarity of the phase supply must be reversed.



All electrical work is only to be carried out by a qualified electrician.

The motor connections are only to be altered if, after the replacement of a motor, gear or pump, the direction of rotation requires correction according to the following table.











To check rotational direction, disconnect the implement holder from the main motor shaft, close and lock the lid. Only start individual drives for a short time. In the following table, rotational direction is always with respect to the view from above the machine.

Drive	Where to test?	Direction of rotation	Arrow towards
Main motor	Spin plate beneath the bowl floor	Towards the right	End shield
Gear motor	Beneath the connecting flange	Towards the left	Ventilation flap
Vacuum pump	Motor ventilator fan	Towards the right	Ventilation flap
Hydraulics	Motor ventilator fan	Towards the right	Ventilation flap

4.2 Function testing and test run

The basic functions of the UM/SK 150 have been factory tested. In order to ensure, however, that no damage has arisen during transport or installation, a test run of the machine should be carried out shortly after its setting-up.

We emphasize once more that only persons properly familiar with the functioning of the machine are permitted to operate the UM/SK 150

What to do first..	...and then carry out and double check!
Attach the blade holder to the tool holder of the machine base with the wing nut pointing upwards and ensure that the nut is tight. If necessary, tighten firmly with the open-jawed spanner supplied.	 <p>The blades must be absolutely securely mounted. The slanting edge of the blade must be towards the bowl base to obtain optimal circulation of the material.</p>
Three quarters fill the bowl with warm water (ca. 50°C / 122°F).	 <p>The UM/SK 150 requires headroom for perfect product processing, i.e., the bowl must not be filled beyond 3/4 capacity.</p>
Close the lid and lock the toggle seals.	
Manually select 400 mbar vacuum pressure on the OP control unit. pabs = 400 mbar = 60% vacuum.	<p>7 8 9</p> 
Switch on the vacuum pump.	 <p>Read off the vacuum pressure from the OP display. The vacuum pump switches off automatically once the selected vacuum has been achieved.</p>
Switch on mixing baffle to mix.	
Switch on main motor. Allow the machine to run for five minutes.	 <p>The vacuum test is passed if the vacuum loses less than 50 mbar over 5 minutes, with the machine running.</p>
Check that the functioning of the steam valves and	
the water valves correspond to the description of the OP function keys.	
Open the aeration valve	 <p>Pressure in the machine will be released.</p>
	 <p>Check the vacuum manometer to ensure that the machine is no longer under pressure before opening the machine lid.</p>

What to do first..	...and then carry out and double check!
Unlock the toggle seals and then open the lid. Tip and empty the container.	 Wait until the contents of the bowl are stationary to avoid the danger of splashing. Always wear protective safety gloves if surfaces are hot.

4.3 Starting-up the hydraulic system



The hydraulic system must only be started up by our installation engineers or similarly qualified specialists.
Detailed instructions (See " Maintenance of the hydraulic system" on page 54.)

Rapid alteration between pressurizing and de-pressurizing is to be avoided because:

- the associated pressure waves damage seals
- may burst pipes and hoses
- and may damage important functional parts.



The working pressure of the hydraulic system is 120 bar / 1700 PSI.
This high pressure is hazardous. Hydraulic fluid may be expelled through the minutest fissures in the hydraulic system and cause injuries.
The safety precautions must be observed exactly, even for examination of the hydraulic system. All work on the hydraulic system must be carried out with the machine depressurized.
Connections must not be loosened or tightened on an hydraulic system which is under pressure. Without fail, the motor must first be shut off and the pressure released.

5. Operating Panel

5.1 The machine is controlled via the OP17

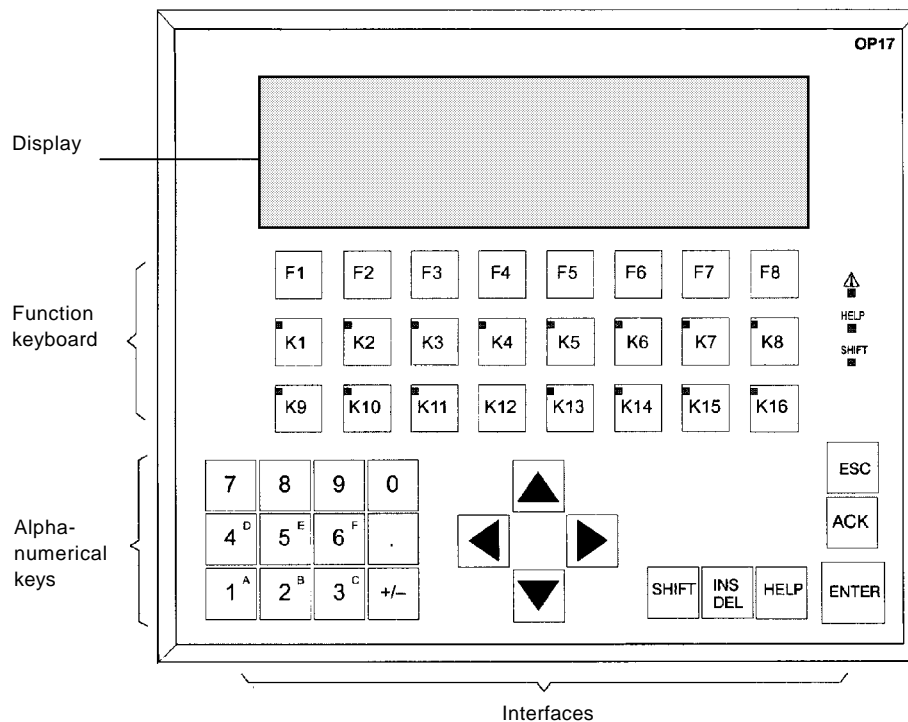

LC-Display

High-contrast LC display with LED back-lighting. The following displays can be configured:

4 lines each of 20 characters; height of characters is 11 mm

8 lines each of 40 characters; height of characters is 6 mm.

Function keyboard

24 keys (F1 to F8 and K1 to K16) for calling freely configurable functions. The two-color LEDs (red/green) embedded in keys K1 to K16 can be driven by the PLC.

Softkeys

16 function keys (F1 to F8 and K1 to K8) can be used as function keys too. Soft keys can be configured with functions which vary from screen to screen.

System keyboard

22 keys for calling universally valid, standard functions (keypad, arrow keys, etc.).

Data buffer

The OP7 operates without a battery and is therefore maintenance-free. Operating data are retained in a non-volatile state in the flash memory on the OP. The message buffer is backed up for several hours after the power supply is turned off.

The internal hardware clock has reserve power for several days after the power supply is turned off.

The OP17 can be optionally upgraded with a lithium battery. The battery is not supplied with OP as a standard component.

Interfaces

1 x RS232/TTY active, for connecting to the PLC/computer/printer

1 x RS232/TTY passive, for connecting to the PLC/computer/printer

1 x RS422/485 for connecting to the PLC/computer

Fuse

Maintenance-free electronic fuse.

5.2 The keyboard of the OP 17

Keyboard

The OP17 are operated by means of the keyboard. There are three different keypads on the keyboard with





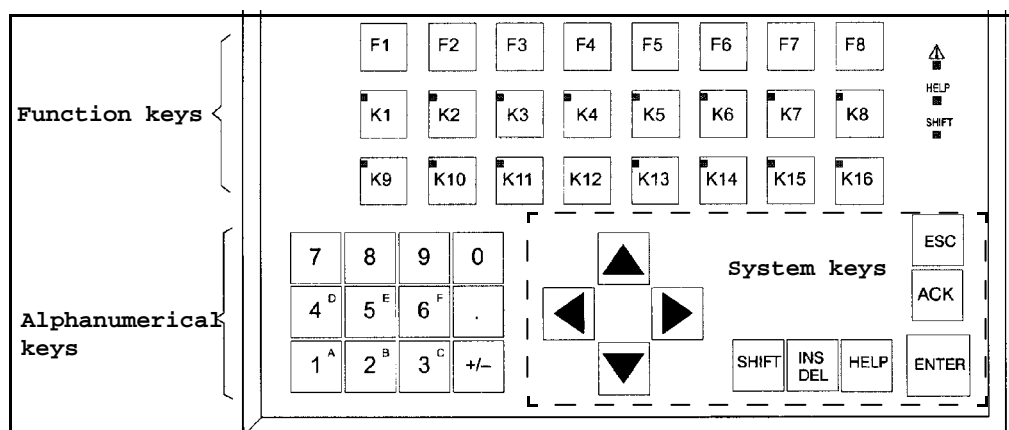

- System keys
- Alphanumerical keys and
- Function keys



The figure shows the keyboard of the OP17.

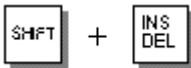

Simultaneous pressing of more than one key may result, among other things, in erroneous input.

5.2.1 System keyboard

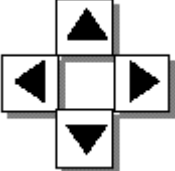
Key	Function	Purpose
	Shift	<p>Enable the second function of dual-assignment keys – for example, shift of numeric keys 1 to 6 for inserting characters A to F or switching from DELETE mode to INSERT mode.</p> <p>The enabled SHIFT key is indicated by the SHIFT LED. The second function of a dual-assignment key can then be called.</p> <p>The SHIFT LED is located on the right of the function keys.</p>
	Delete	<p>Delete the character, when alphanumeric values are being entered, at the current cursor position. All the characters thereafter are moved one position to the left.</p>
	Insert	<p>Insert a blank, when alphanumeric values are being entered, at the current cursor position. All subsequent characters are moved one position to the right.</p>
	Help (information text)	<p>When the assigned HELP LED is on, information text relating to the current display can be viewed on the screen. The HELP LED is located on the right of the function keys.</p>
	Enter	<p>Enter and terminate your input. This means that, among other things, you also change from message level to screen level.</p>
	Acknowledge	<p>Acknowledge alarm messages. The ACK LED</p> <ul style="list-style-type: none"> - is on, when at least one unacknowledged alarm message is present, - flashes, when only acknowledged alarm messages are still queued. <p>The ACK-LED (icon) is located on the right of the function keys.</p>

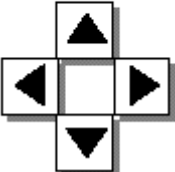



Key	Function	Purpose
	Escape	<p>Escape The ESC key has the following functions:</p> <ul style="list-style-type: none"> - Cancel <p>Cancel field inputs provided that they have not been terminated by pressing <ENTER></p> <ul style="list-style-type: none"> - Branch backward <p>Within a screen, you branch back to the configured cross-jump destination (by default, the last position called) and, finally, from the start screen to the message level.</p> <ul style="list-style-type: none"> - Hide system message <p>Hide a non-serious system message. Cancel display of information text Cancel the display of information text to return to the previous display.</p> <ul style="list-style-type: none"> - Reset while scrolling through messages <p>Cancel scrolling through messages to reset the display to the current message.</p> <ul style="list-style-type: none"> - Cancel Download mode <p>Cancel Download mode as long as data are not being downloaded to the OP. The OP acknowledges the abort by issuing a system message.</p>
	Move cursor	<p>Depending on the operating situation, the cursor is moved one character, field, entry or display to the left, right, up or down.</p> <p>The arrow keys have a repetitive function, i.e. if you keep a key pressed, your input is repeated after a short delay until you release the key.</p>
 + 	Scrolling in symbolic lists	Scrolling in symbolic lists and calling of the extended font.

Key combinations

Key	Function
 	Inhibit alarm messages

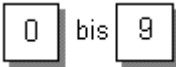
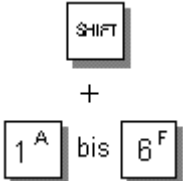
Key	Function
	Overall Reset With this key combination, you erase the configuration memory when turning on the OP's power supply.

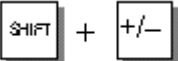
5.2.2 Alphanumerical Keys

Key	Function	Purpose
	Input numerical characters	Input numerical characters 0 to 9. The numeric keys have a repetitive function, i.e. if you keep a key pressed, your input is repeated after a short delay until you release the key.
	Input alphanumerical characters	Input alphanumerical characters A to F.
	Change sign	Change sign from "plus" to "minus" and from "minus" to "plus".
	Set contrast	Set display contrast.
	Enter decimal point	Enter the decimal point or comma.

5.2.3 Function- and Softkeys

Function keys

A function key always initiates the same action on the OP or on the PLC, irrespective of the screen that happens to be open (global significance on the OP). These actions include opening a screen or starting a printout of a screen, for instance. The function keys for the devices shown below are as follows: F1 to F8 and K1 to K16.

Soft keys

Soft keys are function keys which initiate different actions on the OP or PLC from screen to screen (local significance on the OP). You can configure the following function keys as soft keys: F1 to F8 and K1 to K8.

Two-tier soft keys are particularly suitable for implementing binary states and machine functions – for example:



The following table explains the control procedure of the OP17. Since the OP17 displays have been specially designed for your machine, they may differ slightly from the examples shown.

5.3 Information Text

Information text contains information about the current display contents. It is created during configuration with ProTool and provides additional information in the language set on the OP. Information text can be configured for

- event messages and alarm messages
- screens
- screen entries
- input fields and dual I/O fields
- recipes, recipe entries
- schedulers

Information text can be used to convey, for example, information to the user on the current assignment of the soft keys. Information text relating to an alarm message may contain additional hints, for example, on the possible cause of the alarm and how to remedy it.

5.3.1 Displaying information text

The availability of information text is indicated by the HELP LED being lit. Configured information text can be output by pressing the HELP key on the OP.

If the cursor is positioned in an input field or in an I/O field for which information text is available (lit LED), the information text is output by pressing the HELP key. Pressing the HELP key a second time displays information text associated with the screen entry, if configured.

If the HELP key is pressed in a field for which information text is not available, information text associated with the screen entry, if configured, is displayed directly.

5.3.2 Information text about screens

Configured information text associated with a screen is obtained either by pressing the HELP key in the directory when the cursor is positioned on the corresponding screen or within a screen when the cursor is positioned on the screen title.

5.3.3 Scrolling through information text

The keys <up> and <down> are used to scroll through information text, if appropriate. The ESC key terminates display of information text, and the previous display is shown again.

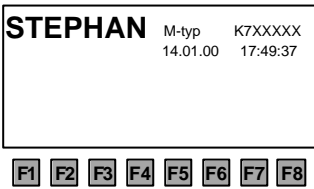
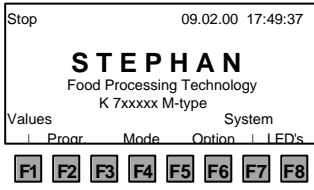
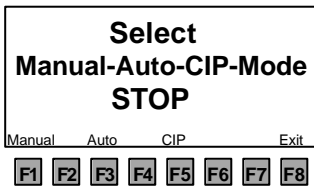
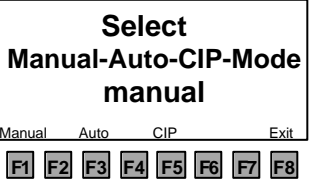
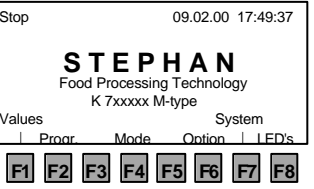

5.4 Manual operation and input of nominal values

What to do	The display shows	Available functions
Step 1 Switching on the OP		The initial display shows the machine type, order number and the date and time. Softkey functions are not active from here. You can proceed to the main menu by pressing the Enter key.
Step 2 Confirmation with ENTER		Main menu: The following sub-menus can be opened with the soft keys. F1 Show nominal and actual values F2 program selection and charge counter, automatic drive F4 Operating mode selection F6 Order-specific options F7 System menu for OP F8 LED-Test of light-emitting diodes
Step 3 Selection of operating mode menu with F4		Operating mode menu: Select with F1 Manual operation F3 Automatic operation F5 CIP F8 Return to main menu
Switch the machine to manual operation with F1		You are still in the operation mode selection menu. But the status message „Hand“ is displayed since the machine is switched to manual mode. The machine may now be directly controlled via the machine function keys of the OP. With the soft keys you can switch to another operating mode or back to the main menu, as described.
Use F8 to switch back to the main menu		The status message in the upper left corner of the display now shows manual operation.

What to do	The display shows	Available functions
Use F1 to display the values		Use the arrow keys of the OP to position the cursor on the desired values. Use the numeric keys to enter the numbers and confirm them with the ENTER key.
Use F8 to switch back to the main menu		The status message in the upper left corner of the display now shows manual operation. Use F6 to display the option menu.
You can select the options for temperature- and vacuum		The status message in the upper left corner of the display now shows manual operation. F3 When in manual operation switching the vacuum off can be activated with the temperature rising or falling. F4 When in manual operation "maintain temperature" can be activated for direct and indirect heating.
Edit program name		<ol style="list-style-type: none"> 1. Select screen "Program editor". 2. Put cursor with arrow keys to namen field. 3. Edit program name with max. 20 signs . 4. Program name is stored by pressing softkey STO. 5. The program name is additional showed in screen "Program - preselection" and in screen "Values". <p>Note: This function is not available with PLC S5-95U</p>

5.5 Automatic operation, Program and Charge selection, Start program

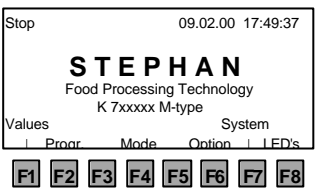
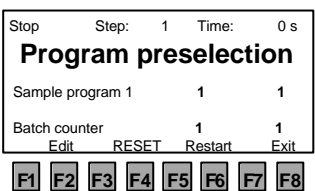
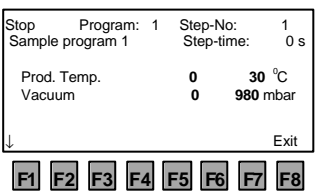
What to do	The display shows	Available functions
Carry out steps 1 to 3 exactly as for the selection of manual operation. Then use F3 to switch to automatic operation.		The status message: "Auto" is displayed, since the machine is switched to automatic mode. With the soft keys you can switch to another operating mode or back to the main menu, as described.

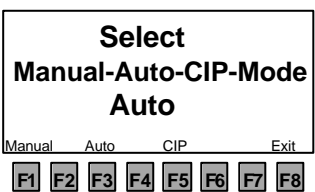
What to do	The display shows	Available functions
Use F8 to switch back to the main menu		The status message in the upper left corner of the display now shows automatic operation.
Use F2 to select a program. After entering the numbers, start the program with the OP "Auto start" key.		Use the arrow keys of the OP to move the cursor to the desired values. Use the numeric keys to enter the program number and charge number and confirm them with the ENTER key. F2 program edit mode. F4 Returns an interrupted program to Stop status. F6 Recommence program after programmed time delay. F8 Return to main menu.
Use F8 to select the main menu and then F1 to display values.		Value settings: You can follow the single steps of the running program. All nominal and actual values are displayed. Use "Auto start" to stop a running program (LED goes out) and start it once more at the same place by pressing "Auto start" again (LED lights up). You can even change the nominal values of the running program, but you must learn completely the programming mode beforehand.
Use F4 to continue the program.		This message is displayed when a halt is programmed. (for example for additions by hand). The Auto start key LED flashes. F4 program is restarted and display switches to show values. F8 Return to main menu.
Use F8 to switch to the main menu, F4 for the selection menu and then F5 for CIP operation		Automatic cleaning operation is selected from the operation-type menu with F5 CIP. The status message "CIP" is displayed. With the soft keys you can switch to another operating mode or back to the main menu, as described. program selection and operation are as for automatic mode.

5.6 Program editing

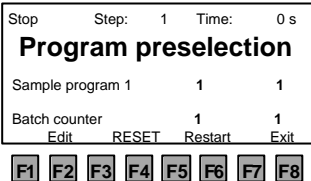
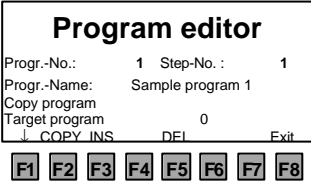
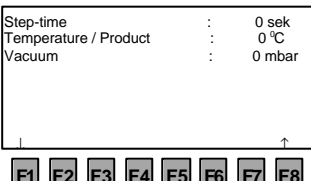
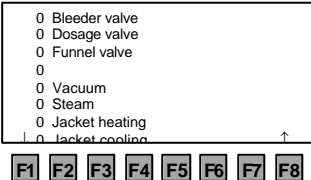
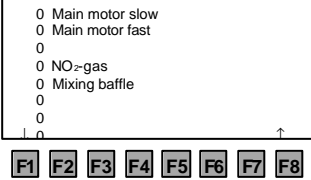
What to do	The display shows	Available functions
<p>Step 1 From the main menu, press F2.</p>	 <p>Stop Step: 1 Time: 0 s Program preselection Sample program 1 1 1 Batch counter 1 1 Edit RESET Restart Exit F1 F2 F3 F4 F5 F6 F7 F8</p>	<p>You are now in the program selection menu. F2 program edit mode F4 Returns an interrupted program to Stop status. F6 Recommence program after programmed time delay. F8 Return to main menu.</p>
<p>Step 2 Use F2 to switch to the program editor.</p>	 <p>Program editor Progr.-No.: 1 Step-No.: 1 Progr.-Name: Sample program 1 Copy program Target program 0 COPY INS DEL Exit F1 F2 F3 F4 F5 F6 F7 F8</p>	<p>Enter the program No. and step No. to be edited in the initial display. Confirm entered figures each time with ENTER. F1 Use this to scroll on to the input stage for variables and switching functions of the current program step. F2 Copy the current program. For this purpose, assign new program No. (Target) F3 Copies the current program step and adds it in F5 Erases the current program step. F8 Return to main menu.</p>
<p>Step 3 Use F1 to scroll to the variable input stage. Here, 15 has been entered as the step time (move cursor with the arrow keys)</p>	 <p>Step-time : 0 sek Temperature / Product : 0 °C Vacuum : 0 mbar F1 F2 F3 F4 F5 F6 F7 F8</p>	<p>Enter step time and nominal values here. Confirm entered figures each time with ENTER. F1 Scrolls on to the switching functions F8 Scrolls back to the previous screen. Caution: Step time „0“ is evaluate as Program end!</p>
<p>Step 4 Use F1 to scroll on to the input stage for switching functions. Here, 1 has been entered for aeration.</p>	 <p>0 Bleeder valve 0 Dosage valve 0 Funnel valve 0 0 Vacuum 0 Steam 0 Jacket heating 0 Jacket cooling F1 F2 F3 F4 F5 F6 F7 F8</p>	<p>Enter 1 to select the switching function of the current program step here. Further screens display all the available functions for your machine. (0 = not selected) Confirm entered figures each time with ENTER. F1 Scrolls on to further switching functions F8 Scrolls back to the previous screen</p>
	 <p>0 Main motor slow 0 Main motor fast 0 0 NO₂-gas 0 Mixing baffle 0 0 F1 F2 F3 F4 F5 F6 F7 F8</p>	

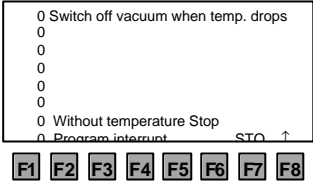
What to do	The display shows	Available functions
<p>Step 5 Use F1 to scroll on. Use F7 to save the step.</p>	 <p>The screenshot shows a display with the following text: "0 Switch off vacuum when temp. drops", "0", "0", "0", "0", "0", "0 Without temperature Stop", "0 Program interrupt", and "STO ↑". Below the display are eight function keys labeled F1 through F8.</p>	<p>Once the step has been saved with F7, the message "Step saved" appears on the display. The step No. is automatically incremented by 1. As described in steps 3 to 5, enter further program steps. F7 saves the progr.-step F8 Scrolls back to previous screen.</p>

6. Operating the machine

6.1 Implement fitting



There is a risk of injury when handling sharp blades and implements.

What should happen	What to do	Key	The result!
Reduce excess pressure/vacuum	Open aeration valve.		The machine is not under pressure.
Open container	Unlock toggle seals Open lid.		Lid is open
Implement fitting	Attach working insert to motor shaft, put on cap nut and tighten with spanner SW41 7 SW 19		Implements are ready for use.









6.2 Loading the machine.



The, UM/SK 150 requires headroom for perfect product processing, i.e., **the bowl must not be filled beyond 2/3 capacity.**

What should happen	What to do	Key	The result!
Loading the machine via the opened lid.	Open aeration valve.		Machine is de-pressurized.
	Unlock toggle seals Open lid.		Lid is open
Manual loading	Put in product.		
Close container.	Close the lid and lock the toggle seals.		The machine is ready to process.
Loading via measuring hopper or a hose from a separate container.	Fill hopper or container		
	Enter vacuum pressure on the control panel of the OP control device (the required value is to be determined by trial). (See "Manual operation and input of nominal values" on page 17.)	7 8 9 	
	Switch on the vacuum system.		The machine is ready to be loaded.
Manual measuring.	Open hand valves.		



6.3 Mechanical and thermal product treatment.

What should happen	What to do	Key	The result!
Process product mechanically, i.e. slice, cut, mix, stir, emulsify, etc.	Switch on mixing baffle		
	Select main motor revs. at the OP. (See " Manual operation and input of nominal values" on page 17.)	7 8 9 	
	Switch on main motor		
Indirect product heating or temperature maintenance.	Open double shell steam valve.		The function is switched off automatically once the pre-selected temperature has been reached.
Direct product heating.	Open aeration valve or		Excess pressure is thus kept low in the container. The vacuum is switched off or the aeration valve closed once 70°C/158°F is reached.
	Switch on the vacuum system.		
	Open steam jet nozzles		The function is switched off automatically once the pre-selected temperature has been reached.
Direct product cooling.	Pre-select amount of cooling water at the OP. (See " Manual operation and input of nominal values" on page 18.)	7 8 9 	
	Open steam nozzle water valve		

6.4 Emptying the machine



If work is done under pressure or vacuum conditions you must equalize pressure via the aeration valve. Check the vacuum manometer to ensure that the machine is no longer under pressure before opening the machine lid.

What should happen	What to do	Key	The result!
Manual emptying via opened lid.	Open aeration valve.		Machine is de-pressurized.
	Unlock toggle seals Open lid Tip container		
	Remove remains with a spatula.		Watch out for concealed blades.

7. Daily cleaning and maintenance











Cleaning, disinfection and sterilization are basic requirements of every process in the food production industry and technology. Additionally, thorough cleaning extends the life of the machine and in particular the seals considerably. Complete instructions for the cleaning and disinfection processes are to be found in the technical appendix. (See "Cleaning and disinfection" on page 57.)

After production has been ended, cleaning the UM/SK 150 should restore it to a germ-free condition ready for use. The frequency and intensity of cleaning and disinfection required depend fundamentally on the degree of contamination arising from the production process.

7.1 Cleaning procedure

Cleaning may be carried out manually with scrubbing brushes or with the assistance of machine functions according to the following table. High pressure hoses should not be used.

What to do first..	...and then carry out and double check!
Fill bowl to 2/3 full with warm water and add neutral detergent with disinfectant action. Switch to manual mode and select a temperature of 50°C at the OP. (See "Manual operation and input of nominal values" on page 23.)	 Fatty contamination is removed by water temperatures over the melting point of fat (50°C).
Close and lock lid. Switch on mixing baffle to mix.	 During the removal of protein-containing dirt with water over 60°C, coagulated protein may burn in on surfaces and should therefore quickly be removed with the appropriate cleaning materials.
Switch on main motor at low revs. to start with and then run for ca. 2-3 minutes at 3000 rpm.	
Switch on the vacuum pump.	
Open toggle seals, open lid, tip and empty bowl. Rinse with clean water.	 Wait until the cleaning water has come to rest to avoid splash danger.
Remove working insert from the motor shaft and clean implements separately. Clean the drill holes of the working insert should be cleaned with a bottle brush. Remove lid seal from the lid nut, clean and replace.	 Take care when handling blades and implements. Never put bare hands into a full bowl. Concealed blades carry a high risk of cuts and injury.

What to do first..	...and then carry out and double check!
The vacuum dome and tube may be thoroughly cleaned after removing the safety and vacuum valves and opening the lid.	
The safety valve should be cleaned daily, to prevent accumulation of product residues. To clean the valve carefully unpressurized with water or air, it may be lightly aerated manually or unscrewed. (See " Safety valve" on page 39.)	 Damage or removal must not occur to the leading which maintains the release pressure settings.
If necessary, the casing and drive of the emptying valve may be separated by releasing the locking clamps and cleaned manually.	
Lacquered machine parts should be cleaned with a sponge and mild soapy water.	 Never spray down motor, motor casing, switching cabinet etc., with water or cleaning solutions.
Use only a dry cloth to clean the hydraulic equipment.	 Electric and hydraulic equipment should only ever be cleaned dryly.

7.2 Maintenance work for 8 hour operation Maintenance work

When?	Where?	What to check...	...and what to do.	Page
Daily	Bowl and lid	Seals and running sleeves in lid and bowl rims	replace damaged seals clean running sleeves and replace them if wear is noticeable on the upper surface.	49
	Implements	Implements must be sharp and undamaged, if not,	they should be replaced. Blades should be sharpened. (See "Sharpening the blades" on page 49.)	35
	Mixing baffle Gears	Check lubricant at inspection window	if necessary refill with lubricant.	53
	Pneumatics	Condensation water	check for contamination.	40
	Shaft seals	of the mixing baffle motor and the main motor	lubricate once daily and after every cleaning	
	Safety valve	must be free moving and not encrusted with product residues to function perfectly.	Check freedom of movement by manual operation. If the safety valve has been released it must be cleaned immediately.	39
Weekly	Hydraulics	Oil level	if necessary fill up with hydraulic fluid	54
	Pneumatics		Fill up oiler	40

When?	Where?	What to check...	...and what to do.	Page
Every 6 months	Steam Unit	Check steam filter for dirt.		41
Yearly	Hydraulics	Condition of hydraulic fluid	Change hydraulic fluid	54
Every 2 years	Mixing baffle gears	Oil change intervals	Change lubricant	53

8. Machine description

All parts of the UM/SK 150 which come into contact with food products are of non-rust stainless steel or other physiologically harmless material.

8.1 Motors

8.1.1 Main Motor

The main motor is a high-performance motor with a F/H insulation.



The motor shaft may be damaged if the main motor is switched on when implements or foreign bodies are in the machine. The use of force may damage the motor shaft and should therefore be avoided.

8.1.2 Gear motor

The gear motor for the mixing baffle mounted on the lid is a durable, low-maintenance drive. It is pre-lubricated and connected ready for use.

8.1.3 Positioning selector switch

The lid can be opened only when the mixing baffle, after switch off, stops in certain position. Furthermore, the mixing baffle should not stop in the vicinity of temperature probe and knives.

This task is done by an positioning selector switch. A magnetic limit switch is actuated by a switch magnet mounted in the centrifuge disc. The switch off position can only adjusting electronically in the switch board via a time contactor.

Actuation of this magnetic limit switch -after the mixing baffle has been switched off manually or by program control- starts a time relay in the control cabinet which turns off the gear motor at the end of the desired time.

Simultaneously, the brake is actuated and keeps the mixing baffle in position.

8.1.4 Shaft sealing of the main and gear motors

The sealing of the main motor shaft is by means of an integral seal system with two radial shaft seals (vacuum and pressure).

Axial immobilization is by means of 2 thread bolts with nuts.

Lubrication is by means of the lubrication nipple of the oil supply pipe.

During re-equipment with an axial face seal, the pipes provide for the supply and removal of the inhibition medium.



Only the use of a completely undamaged sealing flange guarantees a perfect bowl seal. A faulty seal must be replaced immediately, since it may damage the main motor. (See "Daily cleaning and maintenance" on page 31.)



We recommend you to store a complete replacement sealing system including running sleeves.

8.1.5 Mixing baffle

The mixing baffle with mounted scraper promotes product circulation and scrapes the bowl and lid clean.

8.2 Working inserts

The working inserts are manufactured from highly resistant alloyed stainless steel. Their form and size are optimally suited to the motor performance, bowl shape and the process to be carried out.

8.2.1 Blade insert

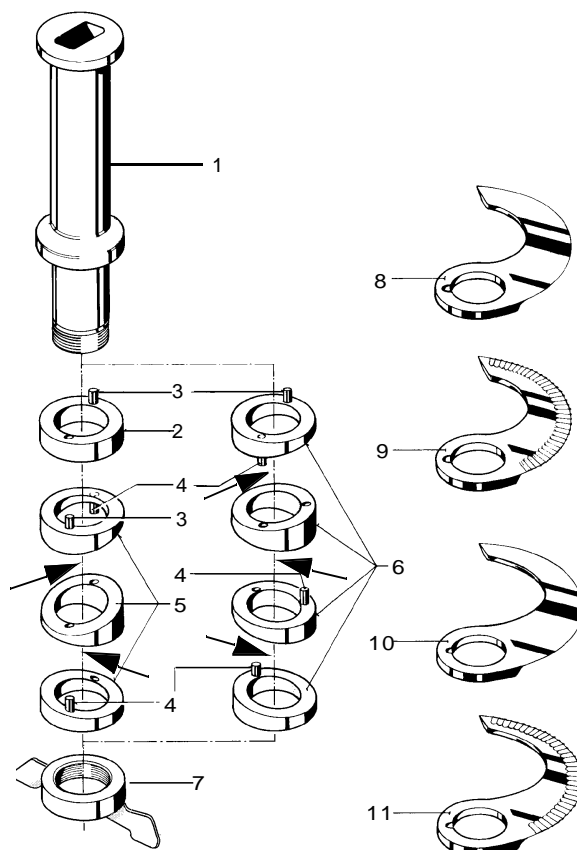

The blade insert for 2 blades (3 blades) consists of:¹

1. here, 2 blades are shown in use (the arrows show the knife mounting position)

Pos. No.	Description
1	the knife shaft
2	a pressure ring* (left out at 3 knives)
3 / 4	the appropriate pins
5 (6)	the slanting set, 3 rings (4 rings)
8-11	two knives (three knives)
7	the wing nut



The pressure ring (2) may be mounted over or under the angle ring assembly as you prefer. This enables the higher or lower positioning of the blade set. The angle rings (3) determine the angle of the blades. They are numbered from the top downwards and supplied with connecting pegs and drill holes.

Assembly and mounting of the blade insert :

The following procedure is to be observed when assembling the blade insert. The sharp beveled edge of the blade must always point towards the bowl floor to enable the required material circulation

After assembling the blade insert, attach it to the implement holder of the machine base with the wing nut (5) on top. Tighten the wing nut to the right with the specially designed spanner supplied.

8.3 Container

The container is manufactured to conform to German pressurized container regulations. The lid is secured to the bowl by 2 toggle seals for safety. The seal between bowl and lid is by means of a specially designed silicon-rubber washer. In these conditions, the container is vacuum fast and, depending on specification, pressure fast. (See "Machine Data" on page 10.)



The machine can only be switched on if the lid is completely fastened since the lid safety switch mounted beneath the lid torsion of the bowl blocks all processing functions when the lid is open. This safety switch must not be removed.

8.3.1 Double shell: Water and steam

For indirect heating or cooling, the bowl is equipped with a pressure fast double shell. The heating medium is steam from the steam producer supplied depending on the model, or the customer's steam production system.

The steam condenses on the side of the bowl and transfers heat energy through the bowl to the product. The condensation produced is removed by a constantly running condensation extractor.

Cold water from the main or cooling tower water may be used as the cooling medium. Control of the water/steam and double shell drainage is by means of the OP control panel.

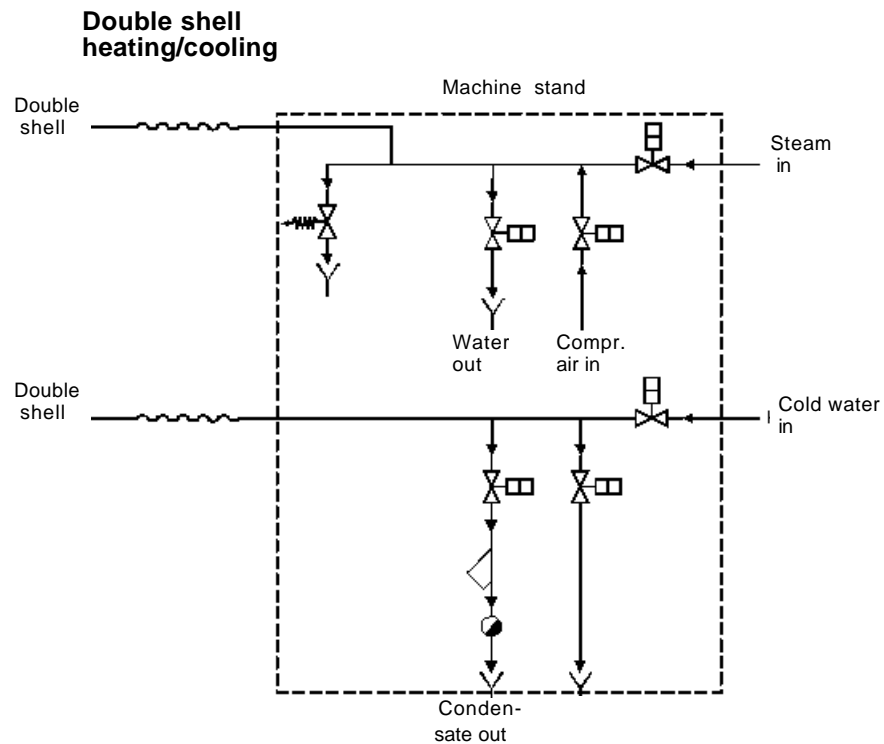

An impermissibly high pressure build-up in the double shell is prevented by an excess pressure safety valve. Steam from the safety valve requires particular education.

8.3.2 Steam injection

Hygienically pure steam is injected by means of spring-loaded check valves in the bowl base. Steam pressure of ca. 0.7-1,2 bar (9.9-17.0 PSI) is required to open the valves. Should the pressure fall below this value, the valves shut automatically to prevent the product intruding into the steam delivery piping. The maximum amount of steam injectable variegates depending on the product and initial steam pressure.

Double shell heating/cooling

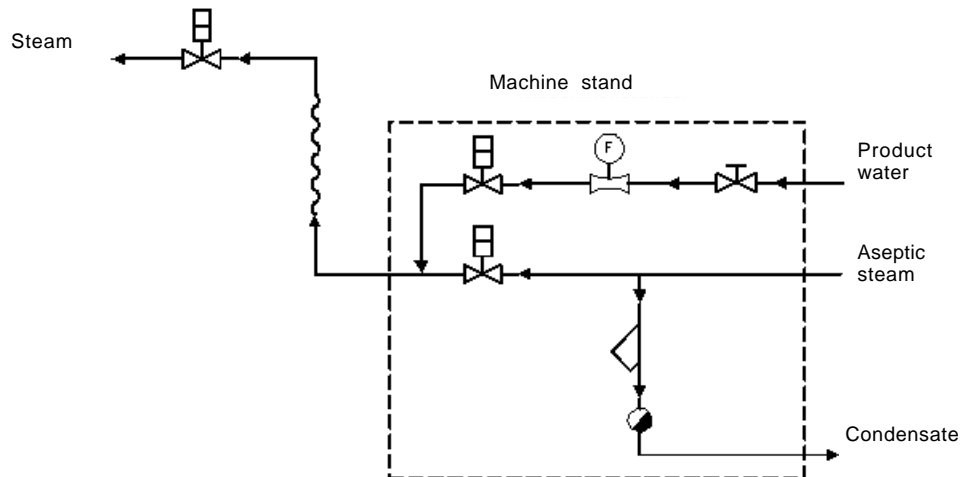

8.3.3 Emptying valve

A pneumatically controlled floor-valve is fitted in the lower bowl area for the emptying of fluid and partially fluid products. Electro-pneumatic operation is controlled by means of the OP control panel keys or by the program. An outlet bend is fitted to the outer side of the valve for emptying into basins or wagons. The pneumatic control hoses are provided with quick-release connectors i.e. the valve may be removed from the piping and in a few hand operations taken apart, for example for cleaning or maintenance.

8.4 Safety features

Prevention of	Prevention by
Excess pressure in container	180° pipe bend Safety valve DN 40 release pressure 0,1 bar/1.4 PSI Safety valve DN 40 release pressure 0,8 bar/11.4 PSI-> 116°C/ 241°F
Opening of measuring or emptying valves due to excess pressure in container	Manometer with switching contact Pressure measurement convertor - SPS (Measuring and emptying valves lock automatically at container pressures >0.)
Opening of measuring or emptying valves at temperatures > 95°C/200°F in the container	Temperature sensor with two precision resistors Resistor 1 in "set value control" safety circuit (at a temperature > 95°C/200°F in the container, measuring and emptying valves will lock automatically.) Resistor 2 in SPC (Monitoring of the safety circuit and heating element shut-off when nominal values are exceeded)

Prevention of	Prevention by
Switching on of processing functions when lid is open	Limit switch in bowl hinge; pressing of "lid closed" key

8.4.1 Safety valve

The excess pressure valve mounted on the lid is factory set to prevent the permissible pressure in the interior of the bowl being exceeded. Alteration of the release pressure is prevented by leading. The valve must be kept clear of product residues and condensation. Check the proper functioning of the valve before starting process by carefully opening it manually. The valve must be unscrewed carefully and cleaned daily and immediately after it is released. When doing so, ensure no damage occurs to the leading which preserves the release pressure settings.



Alterations to the safety valve may cause serious injury. In addition, the removal of the leading will render void the warranty. The medium passing out of the valve requires particular and non-hazardous removal.

8.5 Hydraulic unit

The hydraulic unit produces the pressure required to move the hydraulic drive.

The unit consists of:

- the container for hydraulic fluid (capacity: 2 Liters)
- the hydraulic pump with drive (flow volume ca. 1,13 l/min)
- the manometers
- the control unit with 4/3 - distributing valve (electronic control).



The working pressure of the hydraulic system is 120 bar / 1700 PSI. This high pressure is hazardous. Hydraulic fluid may be expelled through the minutest fissures in the hydraulic system and cause injuries. The safety precautions must be observed exactly, even for examination of the hydraulic system. All work on the hydraulic system must be carried out with the machine depressurized. Connections must not be loosened or tightened on a hydraulic system which is under pressure. Without fail, the motor must first be shut off and the pressure released.

8.5.1 Hydraulic drive

Drive	Functions
Hydraulic cylinder in the machine base	for tipping the container
Hydraulic rotary drive	to open and close the lid
Hydraulic rotary drives (optional)	to lock lid, inc. position monitoring by proximity switch for automatic process operation.



Pipe fracture safety devices are mounted in the drive supply pipes to prevent the lid falling to or the container swinging back under loss of pressure. Never operate the hydraulic unit without these safety devices.

8.6 Pneumatic

The pneumatic equipment UM/SK 150 consists of:

- the maintenance unit
- a 5/2-distributing control valve
- pneumatically controlled valves, depending on manufacture for product control, cleaning, steam and water supply.

8.6.1 Pneumatic maintenance unit

The maintenance unit removes impurities of the pressurized air and maintains constant working pressure. It thus protects sliding surfaces and seals from dust, condensation etc., and prevents interruptions to operation due to pressure fluctuations in the supply circuit.

The maintenance unit consist of:

- the pressure regulator valve
- a filter (40 mm medium pore size)
- the automatic condensation outlet
- an oiler

The pressure regulator valve maintains working pressure independent of pressure fluctuations in the supply and the air consumption thoroughly constant. The filter cleans the circulating air of solid particles and moisture droplets. The automatic condensation outlet provides a constant, self-operating emptying of the collected condensation. The oiler adds a fine oil mist to the pressurized air to increase operational safety and the life of the pneumatic parts, e.g. valves.

8.7 Vacuum system

The vacuum system prevents or reduces air intrusion into the product and oxidation, and enables the flash cooling of the product.

The components of the vacuum system are:

- the vacuum dome with aeration and vacuum valve
- the vacuum control with pressure measurement convertor switches the vacuum pump off when the preselected pressure is reached. The vacuum pump switches on again as soon as the selected pressure is exceeded by 50 mbar.
- the vacuum regulator with pressure measurement convertor and regulator valve maintains the preselected vacuum constant by forcing air into the suction pipe. The forced air supply

is electronically controlled via a corner type valve.

- the condenser with condensation reservoir
- the vacuum pump produces the vacuum by means of a liquid ring. The rotating liquid ring sucks in gas, compresses to slightly over atmospheric pressure and forces the pressure together with a part of the liquid through the pressure tube. This lost liquid must continually be replaced.

Water (free from foreign bodies) at a temperature of 5°-15°C (41°-59°F) should be supplied to the vacuum pump as the operating liquid. The operating liquid conducts away the heat due to compression and lubricates the axial face seal.

Guide values for the vacuum pump	type LEMA 25
Theoretically achievable ultimate pressure	ca. 35 mbar absolute
Required amount of operating liquid	ca. 240 l/h



Low pressure in the suction pipe and higher temperatures lower suction performance as does counter-pressure in the vacuum pump ($p_{abs} > 1,1 \text{ bar}$)



Do not allow the pump to run when dry.

8.7.1 Vacuum control valve

A control valve with electrical drive and i/p positioning controller are installed in the system.

The vacuum is controlled by adding extraneous air. Max. Air flow rate $d_{VL} = 29 \text{ m}^3/\text{h}$ at $p_{abs} = 1 \text{ bar}$ at entry.

Through the vacuum pump the pressure in the bowl necessary for the selected temperature can be adjusted in connection with the motor-driven extraneous ventilator valve and the control loop "pressure transformer - SPC - extraneous ventilator valve".

A minimum absolute pressure of $p_{Br} = 500 \text{ mbar}$ should be maintained in order to prevent a shortened life or a failure of the evacuation pump due to cavitation damage.

The product temperature can be lowered further by $\Delta T = 2 \dots 3^\circ\text{C}$ through the double-jacket cooling.

This also reduces the risk of "product foaming," as the product temperature is then surely lower than the evaporating temperature.

8.8 Functions of the steam supply unit

Steam desiccation and cleaning	by means of a cyclone-principle water separator with automatic drainage via a condensation divertor
Regulation of steam pressure	by means of separate pressure regulators for the direct and indirect steam transmission systems

Steam filtering for direct steam injection	by means of a particle filter with automatic drainage via the condensation divert
Cleaning and filtering for Diamid supply (where permitted)	by means of an active carbon filter with automatic drainage via the condensation divertor



The filters of the steam supply unit remove metal and dirt particles. The pressure difference over this filter should be ca. 0,2-0,6 bar (2.8-8.5 PSI). If the pressure difference exceeds 0.6 bar (>8.5 PSI) the filters are very dirty and should be cleaned (particle filter) or replaced (active carbon filter).

Guide values for the steam connection	Units	Value
Steam production	kg/h	240
Initial steam pressure	bar (PSI)	6-8 (85-114)
Steam pressure after the pressure regulator double shell	bar (PSI)	2 (28)
Steam pressure after pressure regulator steam nozzle	bar (PSI)	3-3,5 (42-50)

8.9 Water measuring device

The water measuring device enables a precise application of the water required via the steam nozzles in the bowl base. The system usually contains an inductive flow meter type Promag 30A with a serially connected ballcock for reduction of water pressure. The amount of water required may be preselected by entering it at the OP control panel.

8.10 Electronic equipment

The electronic equipment conforms to VDE-regulations 0113 and IEC 204-1. The switch cabinet and the machine are wired ready to be connected and conform to protection type IP 54.



Pressure spraying of the motor or the switch cabinet with water or cleaning solution is not permissible.

The mains connection to the switch cabinet must be laid and connected by a locally authorized electrician according to the wiring diagram. The delivery and installation of the motor, control and pneumatic piping is included in the delivery of the machine.

8.10.1 Control

Control is manual by means of the OP control panel and a touch keyboard. Control may also be by a machine program. If so, the machine will be delivered with SPRO software.

Stored programmable control (SPc)

For stored programmable control, the construction of the device and the wiring are independent of the desired program. The transducing contacts and actuating connectors provided on the machine are connected to the connection plugs of the device.

The desired control program is written to the program memory with a programming device. This program sets out the order in which the transducing contacts are read, the logical operations governing their connection (AND, OR), how the resulting values are addressed to the output terminals and thus how the actuation connectors are switched on or off as the case may be. A program change will not affect the wiring but merely the contents of the program memory. This flexibility is the most significant advantage of stored programmable control.

An SPC system includes an automation system, transducing sensors and amplifiers or signal lamps as the case may be, as well as a control device if necessary.

The automation system consists of a central module with processor and program memory, the input and output modules, the bus system and the power supply module. The voltage from the transducing sensors is switched to the input module. In the central module, the processor implements the program in memory and simultaneously reads the individual ports of the device for voltages. According to these conditions, the processor directs the output module to switch voltage to the corresponding connections. The connected devices or signal lamps will be switched on or off accordingly.



The "Simatic" control buffer battery must be replaced when the main switch is on. The battery has a life of approx. 5 years at 25°C /77°F. If uninterrupted, buffer time is at least 1 year at 25°C /77°F.

SPRO process control

The SPRO software package is designed for automatic process control with flexible programmed control and ease of adjustment to changed process conditions.

The following operating modes are available:

- Manual operation
- Automatic operation
- Programmed operation
- CIP

The selection, input and start of an automatic program are by means of the buttons and touch keys of the operating panel (OP).

What is displayed (LED and LCD display):

- Initial status
- Current program number
- Step number
- Step time
- the variables, nominal and actual values

The LCD display makes it very simple to write and review programs.

- No specialist programming skills are required.
- Up to 20 application programs (each with up to 25 steps) may be programmed in the RAM

program memory. Step time may be up to 999 seconds.

- The inbuilt buffer battery preserves these programs if the power supply is cut.
- An EPROM-memory module contains the system and machine program.

The SPRO software package with the OP control panel operates with the following hardware:

- "Simatic" S 95 U and control panel OP/C
- "Simatic" S 100 U with CPU 103 and control panel OP/C
- "Simatic" S 115 U with CPU 942 - 944 with control panel OP/C

Function keys of the OP

The OP has 16 keys with integral LEDs. Those keys with LEDs are marked with text and symbols for machine functions according to order.

The inbuilt buffer battery of the OP is monitored continually. Should the voltage level drop, the following message appears on the display: "SPC battery empty"

Motor or limit switch interruptions produce messages on the display of the OP. After the problems have been solved, the messages may be cleared by pressing the ACK key of the OP.

The Touch keyboard 2030

The touch keyboard is located on the right hand side of the switch console. It is used to open and close the lid of the machine, operate the lift and tip and right the bowl.

9. Fault repair



All repair work is only to be carried out by the appropriately trained specialists, who should observe both the general and specific accident prevention regulations. This particularly applies to all electrical work referred to in the following fault repair tables.

(See "5. Maintenance and repair, colored safety instructions iii)

9.1 Faults in the drive motors

Faults	Possible reasons	Repair
Motor will not start	Supply is not connected or wrongly connected, e.g., a loose contact	Check voltage across supply and correct. Remedy loose contact.
	Fuse has blown	install new fuse (of correct rating).
	Motor protector has operated	Allow motor to cool, switch on motor protector check motor protector settings.
	Motor protector will not switch. Control is faulty	call in specialists to test and repair.
Motor starts with difficulty	Motor is designed for delta connection but is star connected	Check and correct the control of motor protector.
	Voltage or frequency vary greatly from nominal values, at least on starting. (See "Machine Data" on page 10.)	Correct switching.
Fuses blow or the motor protector cuts out immediately	Winding is faulty	Motor must be sent for repair
	Short circuit in motor or wiring	Remove short circuit
	Motor has short to frame or interturn short circuit	call in specialists to test and repair.
Motor runs in wrong direction	Motor is wrongly connected. (See "Rotational direction check" on page 14.)	Exchange phases.
	Motor is wrongly switched.	call in specialists to test and repair.

Faults	Possible reasons	Repair
Motor overheats (only verifiable by measurement)	Mains voltage deviates by more than 5% from motor nominal voltage. <i>(See "Machine Data" on page 10.)</i> Higher voltages are particularly unsuitable for high polarity motors, since their no-load current is close to the nominal current even at normal voltages.	provide correct mains voltage.
	Motor is delta connected but designed for star connection	Install switching correctly
	Motor overloads	Reduce motor over-load by lesser loads.
	Nominal operating time is exceeded.	observe permissible operating time.
	Nominal duty type is exceeded. If for example the motor overheats because of too frequent switching, it is not sufficient to use a larger motor, since the same conditions will occur.	Restrict operation to the prescribed conditions of operation. Consult Stephan servicing personnel to determine the appropriate drive.
	Cooling air mass is too low, e.g., the cooling air paths are blocked.	ensure unimpeded access and exit for cooling air. Clean cooling fins
	Cooling air has warmed up.	provide fresh air, repair aerator.
Motor growls	Motor is wrongly connected.	call in specialists to test and correct.

9.2 Faults in the hydraulic system



To avoid accidents, the following basic conditions must be observed for all work on the hydraulic system. All work on the hydraulic system is only to be carried out by appropriately trained specialists. The hydraulic system must not be under pressure, hydraulic accumulators must be empty and moving loads secured.

Faults	Possible reasons	Repair
Hydraulics produce no or insufficient pressure	Hydraulic motor runs in wrong direction. (See "Rotational direction check" on page 14.)	Exchange phases.
	Short circuit via faulty valve or faulty Cylinder/pivot drive	Replacement of faulty components
	Oil level in hydraulic reservoir too low	if necessary fill up with hydraulic fluid
	Contaminated hydraulic fluid	Change hydraulic fluid, if necessary clean and re-fill.
	Air in the hydraulic fluid	Remove air from system
	Contamination in the hydraulic system e.g. blocked filter.	Change filter
	Pressure settings too low	Change pressure settings on the pressure limit valve and check with the manometer
	Faulty pump or connection	change faulty part
Hydraulics produce pressure, but the cylinder/pivot drive doesn't function	Check whether relevant magnetic valve is being operated.	Check function, if necessary by emergency manual operation
	The corresponding valve is electrically operated and has no function.	Check whether the pistons can be moved by emergency manual operation. If so, the magnetic coil or the valve must be replaced.
	Check whether the motion of the cylinder/pivot drive is hindered by mechanical impediment or too high load.	
accumulator operation: after loading operation, the pressure in the system falls very quickly although no function is being operated.	Check that the initial gas pressure in the accumulator conforms to the required initial gas pressure (this value is printed on the outside of the accumulator; if unreadable there consult the circuit diagram).	Initial gas pressure may be measured without special tools as follows: release hydraulic pressure slowly whilst observing the manometer. The manometer falls continually as the pressure is reduced until the initial pressure is reached. Here it falls suddenly back to 0 despite pressure being still available in the system.
	At the prescribed accumulator pressure, check whether the system has a leak.	Check the connections and hose fittings first, then the hydraulic circuits must be deactivated and examined section by section.
The pump will not start, although there is no pressure in the system	Check manometric switch for main pressure	call in specialists to test and repair.

Faults	Possible reasons	Repair
The pump will not switch off, although pressure is produced	Check manometric switch for main pressure	call in specialists to test and repair.
	Check pressure limit valve	The pressure set should be at least 10% above that of the manometric switch.

9.3 Faults at the vacuum pump

Faults	Possible reasons	Repair
Pump won't run	Pump has rusted fast after long disuse.	carefully turn the fan blade or loosen the coupler.
	Pump motor is affected. (See "Faults in the drive motors" on page 45.)	call in specialists to test and repair.
Pump runs with difficulty	Sealing water volume is too great	Reduce water volume
Pump sucks poorly	Sealing water volume is too great	Reduce water volume
	Pump is dirty	Clean pump, possibly remove foreign bodies
	Return valve sticks	Clean or replace return valve

9.4 Faults in the electronic equipment

Faults	Possible reasons	Repair
Plant won't switch	main switch is switched off	switch the main switch on
	safety limit switch is switched on	close the lid
	operating voltage is wrong	test the operating voltage
	control fuse is damaged	replace control fuse
	"Simatik" control buffer battery is empty	replace the battery (See "Function keys of the OP" on page 27.)
Error message on the OP display	motors or limit switch faults	After solving the problems clear the display by pressing the ACK key of the OP
OP message " SPC battery empty"	"Simatik" control buffer battery is empty	replace the battery (See "Function keys of the OP" on page 27.)
Functions won't switch	excess-current cut-out works	reset excess current cut-out; call in specialists to test and repair the plant.

10. Maintenance

10.1 Shapening the blades

Only sharpened blades should be installed. Blunt blades must be sharpened on special blade grinding machines. Blades should be wet-ground to prevent oxidation or drawing temper. Burrs should be removed wet with a whetstone.



Should competent grinding work not be possible on site, blades may be sent to Stephan for regrinding.

10.2 Changing the seals

Since the machine may run under vacuum and excess pressure conditions, the pressure chamber must always be hermetically sealable. Therefore, the seals must be checked and cleaned daily.

Damaged seals must be replaced immediately. The running sleeve should be carefully cleaned at the same time. Should traces of broaching be detected, the running sleeves should also be replaced. On re-assembly, ensure that the running sleeves are sealed to the shaft with a fluid sealant resistant to 130°.

10.2.1 Construction of the shaft seals

Shaft seal of the bowl

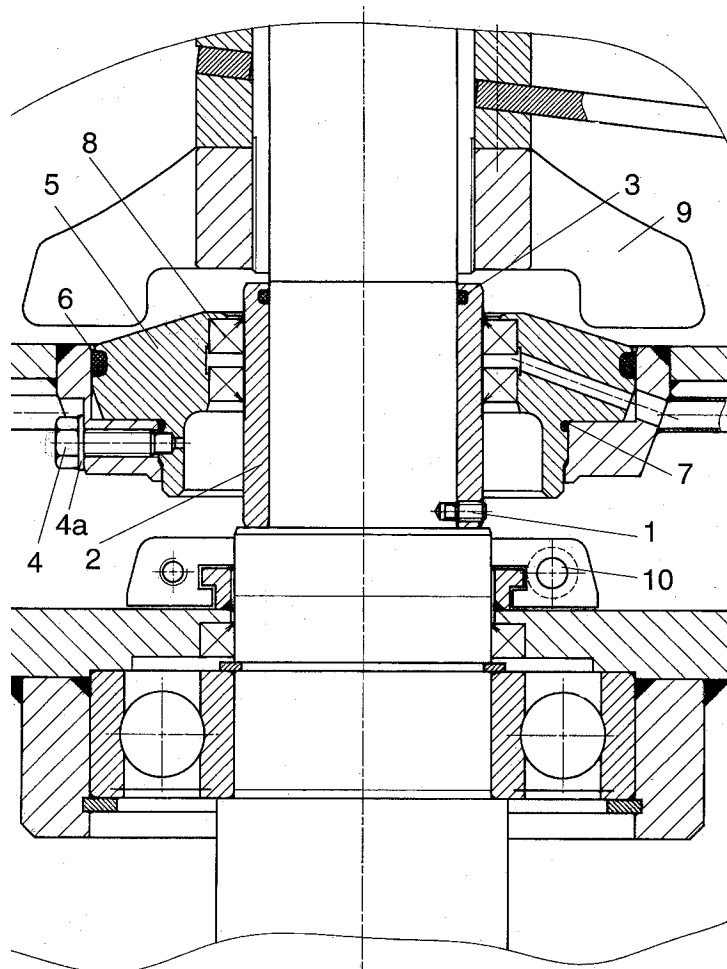

Pos. No.	Description	Part No.
1	Locking screw	
2	Running sleeve	3K0500-47
3	O-ring 2-227	3I0006-11
4	hex. nut	3K2002-06
4a	Sealing disc	3I0208-05
5	Retainer bush	3K0604-03
6	O-ring 2-360	3I0008-21
7	O-ring 2-157	3I0004-19

Pos. No.	Description	Part No.
8	Shaft seal 70x90x10	3I0055-39
9	Working insert	3D0154-01
10	Centrifuge disc	3K1105-02

Disassembly of the main motor shaft seal:

- remove implements
- Unscrew screw Pos.1 (fastening of the running sleeve to the main motor shaft)
- Remove running sleeve Pos.2
- Unscrew nut Pos.4 ca. 10 mm
- Remove retainer bush Pos.5
- Remove shaft seal Pos.8

Mounting takes place in reverse order, with the replacement of the following parts:

- Pos.2 running sleeves (if wear is noticeable on the upper surface)
- Pos.3, 6, 7, 8 (2 pieces)
- Pos.4a

Pos. No.	Description	Part No.
13	Shaft seal 55x72x10	3I0059-05
14	Spacer	3K0301-57

Disassembly of the shaft seal gear motor

- Unscrew cap nut Pos.1
- Remove mixing baffle Pos.2
- Loosen screw Pos.4 (Fastening of running sleeve to gear shaft)
- Remove running sleeve Pos.5
- Unscrew Nut Pos.7 ca. 10 mm
- Remove retainer flange Pos.8
- Unscrew nut Pos.11
- Remove cover plate Pos.12
- Remove shaft seal Pos.13 and spacer Pos.14.

Mounting takes place in reverse order, with the replacement of the following parts:

- Pos.5 and Pos.3 Running sleeves/O-ring (if wear is noticeable on the upper surface).
- Pos.6, 9, 10, 13 (2 pieces)

10.3 Regreasing the seals

The maintenance of regreasing the seals is reduced to a regreasing once a day. The greasing points are protected against dirt with a cap nut.

Type of grease: Klüber Paralique GA 351 or an other physiologically unobjectionable grease.

Quantity of grease: approx. 1x daily 0,25 cm³ = one stroke of the grease gun G 60

10.4 Changing the lubricant of the mixing baffle gear

The mixing baffle gear is provided with the required amount of lubricant at the factory. Required maintenance of the mixing baffle gear is limited to regular lubricant checking at the inspection window and changing the lubricant approx. every 2 years.

The frequency of lubricant changes depend upon the operating temperature, operating hours, and operating conditions. Under adverse operating conditions such as high humidity, and large temperature fluctuations, shorter intervals between changes are advisable.



We recommend gear, circulation or bearing lubeoil to DIN 51517 part 3 ISO VG 220 for ambient temperatures of 0-40°C (32-104°F).



Rolling bearings with grease filling should have the grease changed at the same time. Grease must be inserted to fill one third of the space between the rolling bodies for fast running bearings - motors and gearbox inputs, and to fill two thirds for slow running bearings - in gears and gear transmission outputs.

10.5 Maintenance of the hydraulic system

Both the functional parts and the hydraulic fluid should be maintained regularly, in order to prevent unexpected interruption to operation.

Regularly check the functional efficiency of hydraulic pumps and motors, working cylinders, regulators and maintenance-requiring elements such as filters and sieves.



Alterations to the settings of the hydraulic system may only be performed by specialists familiar with the operation of the system.

The most rigorous safety precautions are to be observed when examining high-pressure hydraulic systems. Connections must not be loosened or tightened on a hydraulic system which is under pressure.

10.5.1 Changing the hydraulic fluid

The pressure fluid should be first changed after ca. 50-100 operational hours. All further fluid changes should be made at intervals of ca. 1500 operational hours. Under adverse operating conditions such as e.g. high humidity or dust levels and large temperature fluctuations, shorter intervals between changes are advisable. Do not mix different types of hydraulic fluid.



Only use hydraulic fluids of viscosities to ISO VG 68 according to DIN 51519. Furthermore, they must be compatible with use in the food products industry and conform to the regulations USDA/FDA-H-1.

Appropriate hydraulic oil: e.g. Gargoyle Arctic SHC 226

10.6 Recommissioning of the hydraulic system

The first run of the machine will be performed by our specialist installation engineers after repair or maintenance work. The following should be observed:

10.6.1 Starting the hydraulic system

Check that the direction of rotation of the motor corresponds to the directional arrow on the pump (viewed from above) by short on/off jogging of the motor. If the direction is correct, run the E-motor. The pump should start without pressure.



As the system is starting, check the hydraulic oil level in the reservoir and if necessary refill immediately.

Allow the system to run for five minutes. The pump must run shortly after starting without cavitation noises.

10.6.2 Deairing the system

Run the system under pressure and move each cylinder and hydromotor back and forth several times by operating single directional control valves. Hydromotors will deaerate themselves, cylinders will be filled and partially deaerated.

Finally deair each cylinder separately. To do so, loosen the uppermost connection or screw joint of the cylinder and move the cylinder back and forth until no more foamy oil is expelled. Then re-close the connection or screw joint.

The hydraulic system is perfectly air-free when there is no more foam in the oil reservoir, the system runs without unusual noises and the piston rods and motors etc. make no jerking movements.

After deairing switch off the system for ca. 30 minutes to release air from the reservoir. Check all screw joints and flanges are fast.



Without fail, check the oil level in the reservoir throughout the entire deairing procedure and if necessary refill immediately

10.7 Charging elevator

The system is constructed for lifting and emptying operations of mobile containers up to a maximum of 400 kp, container included (e. g. standard feeding carriage 200 and 300 liters, hole carriage etc.) Dumping angle: up to 135° maximum. It is appropriate for emptying operations of liquid, pulpy and solid products. Possible dumping heights: up to 3.000 mm. At a dump height of more than 2.000 mm a protective grating is provided. The system is provided with a series ratched brake. This appliance prevents accidents in case of chain rapture. The execution is according to the requirements of the "employer's liability insurance association". The complete system is made of high-grade steel 1.4301 (exception: commercial articles).

Before putting the system into operation the following is to check:

- 1 Electrical connection according to description.
- 2 The chain and sprocket wheel drive is to check regarding its sufficient initial tension and, if necessary, is to regulate. The tension regulation has to be effected at the lifting basket (in the column). After regulating the tension it is imperative to lock the tension spindle. With the right chain tension the non-driving free length of chain can be slightly pressed down by approximately 2 % of the centre distance.
- 3 The oil level in the oiler is to check. Unhindered operation of the chain and sprocket wheel drive and lifting basket.
- 4 Inspection of all fastening elements (transportation of the system may lead to a loosening).
- 5 Perfect operation and free-floating of all movable parts.
- 6 Operatability of the safety device at the receiving basket.
- 7 By shifting the lower end-of-travel switch, the position of the basket can be adjusted so that the receiving basket can run in unhinderedly.
- 8 .The sense of motor rotation is to inspected.
- 9 The dumping height is to adjust according to the intake funnel of the downstream system.

The system may only be set into operation if the inspection of the complete system, the fuses and the safety device is guaranteed.

Maintenance instructions

The is an extremely low-maintenance and easy-care system.

The reversing shaft at the bottom is kept in maintenance-free (due to lifetime lubrication) rolling bearings with suitable sealing.

From time to time the condition of the bearing should be inspected. The chain and sprocket wheel drive and the lifting basket are to maintain in period intervals.

The chain is automatically greased.

In larger intervals it is appropriate to clean the chain by using a dirt dissolvent. When reapplying the chain it is advisable to steep it in warm liquid grease. Keep the chain in this grease bath until it has reached the same temperature and no more bubbles rise (the chain links are sufficiently filled with grease then).

It is advisable to warm up the grease in a water bath as otherwise, when using an open flame, its lubricity may be reduced due to overheating.

Lubricating grease: multipurpose-grease/DIN 51800, drop point 185°C.

When maintaining the chain, the chain tension should be inspected regularly and, if necessary, regulated.

Screws/bolts and welding joints are to inspected regularly.

The electrical equipment and wiring should be checked regularly, too.

Gearing and brake motor

We deliver the gearing filled with grease. 8000 operating hours are maintenance-free, at the most for a three-years-period however.

At the end of this time the gearing is to refill.

The brake motor is fitted out with a two-disc brake.

Adjustment according to attached description

11. Cleaning and disinfection

The purpose of cleaning and disinfection is to break infection chains in the operation.

- Cleaning deprives microorganisms of their breeding medium by removing dirt (including food remains).
- Disinfection inactivates or reduces the number of microorganisms that cause rotting or poisoning of foodstuffs.

11.1 Stages of the cleaning and disinfection process

The precondition for an effective disinfection is always a thorough cleaning. Only in exceptional cases and slightly soiled areas may a combined disinfection and cleaning be carried out, for example with a mixture of aldehydes and surface-active quarternary (mineral) compounds.

In general, the cleaning and disinfection process follows the following stages:

- Precleaning with 40 to 50°C warm water for removal of the worst of the dirt.
- Cleaning with a cleaning solution heated to 60 to 80°C.
- Intermediate rinsing with warm water to remove cleaning solution and dirt-remains
- Disinfection.
- Rinsing with microbially pure water to remove remaining disinfectant.

11.1.1 Factors affecting the effectiveness of cleaning

The effectiveness of a cleaning process depends on the type of cleaning solution, the type of dirt and that of the surfaces to be cleaned, as well as the effective temperature, effective time and the relevant cleaning procedure.



The cleaning procedure appropriate to your machine has been described in the first part of the operating instructions. (See "Daily cleaning and maintenance" on page 15.)

Cleaning solutions

Water: The cleaning power of water may be fundamentally increased by numerous factors such as high temperature, pressure, efficient time, mechanical dissolution of dirt or through the addition of cleaning solutions.

During the removal of protein-containing dirt with water over 60°C, coagulated protein may burn in on surfaces and should therefore quickly be removed with the appropriate cleaning materials.

Alkaline cleaning solutions: Soda lye, phosphates, Sodium hydroxide silicate. Soda lye has a strong cleaning action against high-protein dirt and is therefore preferable for use in protein production processes (meat, cheese etc.) The disadvantage of soda lye is its poor ability to emulsify fat. The weaker alkaline reacting silicates have a better emulsifying capability.

Acid cleaning solutions: are predominantly used for the removal of mineral deposits (calc or scale, milk scale, beer scale etc.) Acids such as hydrochloric acid, tartaric acid, citric acid transform non-water soluble salts into a soluble and rinsible state.

Commercial cleaning solutions apart from their cleaning effects usually also contain foam inhibitors, complexing agents and tensides.

11.2 Disinfection

The most important requirement of a disinfectant for use in a food production process is that it be toxicologically harmless at the required level of dilution.

In addition, the following conditions must be met:

- Fatty contamination is only removed by water temperatures over the melting point of fat (50°C).
- The disinfectant at the level of dilution employed must effect a rapid and irreversible destruction of the microorganisms which have the most damaging effects on the foodstuff produced.
- The efficiency should not be fundamentally affected by the technological process (degree of contamination, type of contamination, pH level, temperature).
- Tolerance of materials and cost efficiency
- Currently, predominantly halogens (active chloride, iodine agents), hydrogen peroxide, peracetic acid, quaternary ammonium compounds and aldehydes are used as disinfectants.

11.2.1 Factors affecting the effectiveness of the disinfection process

A variety of factors play a role in the disinfection process and not only affect the duration and effectiveness of the whole process but also strengthen or weaken each other as the case may be.

Efficient time

The functioning of a disinfectant involves an exponential, rather than sudden, inactivation or extinction of microorganisms. The longer the disinfectant has to work, the better will be the disinfection result. Disinfection of the hands generally requires 0.5 to 3 minutes, while the disinfection of surfaces requires 1 to 6 hours.

Initial germ level

The necessary efficient time to achieve a particular disinfection result is lengthened by the extent of the initial germ level.

Concentration

The speed of germ killing can be fundamentally increased by the use of a higher concentration of the disinfectant. The use of higher concentrations is limited by problems of toxicity on use, the increased danger of affecting foodstuffs (see safety precautions below) as well as the increased corrosive effect on metals.

Temperature

An increase in temperature promotes while a temperature reduction lowers the anti-microbial effectiveness. Some disinfectants, such as peracetic acid or some iodine products are less affected by temperature changes than other media and may therefore also be used at low temperatures.

Protein errors

The disinfectants react not only with the organic components of microorganisms, but also with organic contaminants, in particular with protein chains. The action of certain disinfectants such as chlorine products and iodine products is particularly strongly affected.



Always observe the manufacturer's usage and safety instructions when using cleaning and disinfecting agents! Misuse may cause: serious damage to health, increased residues in foodstuffs and corrosion of the machine.

11.2.2 Disinfection procedure

Fluid preparations of the disinfectant may be applied to surfaces manually with a cloth or with the support of a brush (scouring disinfection), or mechanically, with or without pressure.

Removable short pipe lengths, valves, hoses or other small parts (implements, blades, seals) may be filled with the disinfectant solution in use or immersed in the solution. (Filling and immersion disinfection).

12. Replacement and spare parts



The installation and use of non-Stephan parts may reduce the safety and functioning of the machine. We accept no liability for any resulting damage or injury.



When taking orders for spares, we require the following information:

1. the machine type = UM/SK 150, 2. the order number=K 729.888,
3. module, description and order number from the spares lists.

These data reduce the need for inquiries by our customer services and speed up delivery. You should store replacements in readiness.

12.1 Steam Pressure Table

Pressure Table: Steam at Saturation Point							
Pressure over	Pressure absolute	Temperature of Saturation	Thermal capacity of water	Heat of vaporization	Thermal capacity of Steam	Volume of Steam	Density of Steam
p_e	p	t_s	h	r	h''	v''	ρ''
bar	bar		kJ/kg	kJ/kg	kJ/kg	m ³ /kg	kg/m ³
The overpressure is taken from an absolute environmental pressure of 1,0 bar.	0,01	7,0	29,34	2485	2514	129,2	0,0077
	0,05	32,9	137,8	2424	2662	28,19	0,0355
	0,1	45,8	191,8	2393	2585	14,67	0,0681
	0,2	60,1	251,5	2358	2610	7,650	0,1307
	0,3	69,1	289,3	2336	3625	5,229	0,1912
	0,4	75,96	317,7	2319	2619	3,993	0,2504
0	1,0	99,6	417	2258	2675	1,694	0,5904
0,1	1,1	102,3	429	2251	2680	1,549	0,6455
0,2	1,2	104,8	439	2244	2683	1,428	0,7002
0,3	1,3	107,1	449	2238	2687	1,325	0,7547
0,4	1,4	109,3	458	2232	2690	1,236	0,8088
0,5	1,5	111,4	467	2226	2693	1,159	0,8628
0,6	1,6	113,3	475	2221	2696	1,091	0,9165
0,7	1,7	115,2	483	2216	2699	1,031	0,9700
0,8	1,8	116,9	491	2211	2702	0,977	1,023
0,9	1,9	118,6	498	2206	2704	0,929	1,076
1,0	2,0	120,2	505	2201	2706	0,885	1,129
1,5	2,5	127,4	535	2181	2716	0,718	1,392
2,0	3,0	133,5	561	2163	2724	0,606	1,651
2,5	3,5	138,9	584	2147	2731	0,524	1,908
3,0	4,0	143,6	605	2133	2738	0,462	2,163
3,5	4,5	147,9	623	2120	2743	0,414	2,417
4,0	5,0	151,8	640	2107	2747	0,375	2,669
4,5	5,5	155,5	656	2096	2752	0,343	2,920
5,0	6,0	158,8	670	2085	2755	0,316	3,170
6,0	7,0	165,0	697	2065	2762	0,2727	3,667
7,0	8,0	170,4	721	2046	2767	0,2403	4,162
8,0	9,0	175,4	743	2029	2772	0,2148	4,655
9,0	10	179,9	763	2013	2776	0,1943	5,147
10	11	184,1	781	1999	2780	0,1774	5,637
11	12	188,0	798	1984	2782	0,1632	6,127

Pressure Table: Steam at Saturation Point							
Pressure over P_e bar	Pressure absolute p bar	Temperature of Saturation t_s	Thermal capacity of water h kJ/kg	Heat of vaporization r kJ/kg	Thermal capacity of Steam h'' kJ/kg	Volume of Steam v'' m ³ /kg	Density of Steam ρ'' kg/m ³
12	13	191,6	815	1971	2786	0,1511	6,617
13	14	195,0	830	1958	2788	0,1407	7,106
14	15	198,3	845	1945	2790	0,1317	7,596
15	16	201,4	859	1933	2792	0,1237	8,085
16	17	204,3	872	1921	2793	0,1166	8,575
17	18	207,1	885	1910	2795	0,1103	9,065
18	19	209,8	897	1899	2796	0,1047	9,555
19	20	212,4	909	1888	2797	0,0995	10,05
20	21	214,9	920	1878	2798	0,0949	10,54
25	26	226,0	972	1829	2801	0,0769	13,01
30	31	235,7	1017	1785	2802	0,0645	15,51

12.2 List of assembly parts K 729.888

In the following lists you will find the most important replacement parts for your machine arranged according to module. You should store these in readiness to avoid interruptions to production.

V = replacement parts

Pos. No.	Qty.	Description	Dimensions	Part No.
1151 Support				
	7	rubber buffer (stenflex)	TYP: P N.dim.drawing FM112 WJ	3S4001-08
	2	bearing bush shape c	D1=95,D2=115,D3=128,L=46	3K0506-04
	2	bearing bush shape c	D1=95,D2=115,D3=140,L=46	3K0506-05
	4	rubber foot	LBE 10/20 NI	3M4016-04
	1	support		3A2075-10
1211-5 Motor				
	1	motor cover	DA225	3L0012-01
	1	motor 225 SK-4/2	380/50 440/60 29/33KW	3C0271-15
v	1	o-ring	2-210	3I0006-01
v	1	o-ring	2-334	3I0021-34
	1	centrifuge disc	75/132*20	3K1105-02
1212 Shaft seal				
v	2	sealing disc, inside		3I0208-05
v	2	shaft seal, negative		3I0055-39
v	1	retainer bush		3K0604-03
v	2	o-ring	2-157	3I0004-19
v	1	o-ring	2-360	3I0008-21
v	1	o-ring	2-227	3I0006-11
v	1	running bush		3K0500-47
v	1	sealing disc, inside		3I0208-06
1213 Working insert				
v	2	knife, wide		3D0041-07
	1	pressure ring with pin		3K0311-20
	1	knife shaft	M65*1,5*370	3D0154-01
	1	nut for knife shaft		3K0014-20
v	1	slant-ring set 2-knives, complete with pins		3K0327-01
1215 Stop preventive				
	2	proximity switch induk	BES M12ML-PSC40F-S04G-002	3Q6006-53
	1	pin-and-socket connector		3Q6006-86
1221 Gear motor				
	1	cover for gear		3L0015-03
	1	gear motor RF67DT90L4 BMG.	230/400/50 1,5KW	3C2084-10
	1	proximity switch induk	BES M12ML-PSC40F-S04G-002	3Q6006-53
	1	pin-and-socket connector		3Q6006-85
1222 Gear motor shaft seal				
v	1	retainer bush	66/129,8*36	3K0604-02
v	1	sealing disc, sealing lip inside	M 8 V2A/NBR	3I0208-05
v	1	sealing disc, sealing lip inside	M 10 V2A/NBR	3I0208-06
v	1	running bush	40*55*64 V4A	3K0501-28
v	1	o-ring	2-224	3I0006-08
v	1	o-ring	2-249	3I0006-27
v	1	o-ring	2-153	3I0004-16
v	1	ring	60/71,8*11,5	3K0301-57
v	2	shaft seal	A 55*72*10	3I0059-05
122211 Greasing pump				
	1	greasing pump	GMM-G/4/2/0	3H0076-01
	1	cover hood		3L0042-14

Spare parts
List of assembly parts K 729.888

Pos. No.	Qty.	Description	Dimensions	Part No.
v	1	cover hood		3L0042-15
	1	fat "PARALIQ GA 351"		3S2035-02
		12231 Mixing insert		
v	1	cap nut M.6-Kant	M24*2 links SW41	3K0040-16
	1	O-ring W-nr.s604-70 Silikon	2-330	3I0001-30
	1	mixing insert Um 150	f. Sch+Deck. Abstr. V2A	3D2048-01
		13 Bowl		
	1	Bowl UM 150		3B0350-01
		1322 Double jacket		
v	1	safety valve		3P0001-12
	1	filtering screen	1/2"	3P2020-04
	2	condensate drain, capsule	BP 23	3H4100-03
	2	teflon-corrugated hose	NW32*1200MM LG.	3N2030-36
	1	pneumatic service unit	LFR-1/4-D-Mini	3P4340-17
		1332 Lower bowl area		
		13321 Temperature Probe		
	1	temperatur probe w/o insulating	2xPT100 3-Phase	3Q2011-13
		13422-2 Steam nozzle		
v	1	teflon-corrugated hose	NW32*1200MM LG.	3N2030-36
	4	valve head	-	3K2604-07
	4	o-ring	2-220	3I0021-22
	4	valve inside	-	3K1307-15
	4	pressure spring	-	3M6001-13
v	4	o-ring	2-217	3I0006-03
	4	valve lid	-	3K1330-04
	4	round nut	-	3K0003-01
	4	split-pin	2 x 25	3S0262-02
	1	condensate drain, capsule	BP 23 - 1/2"	3H4100-03
	1	limit of lift		3P0000-90
		134232 Drain valve DN 65		
v	1	valve box	DN 65	3K1350-02
	2	o-ring	2-242	3I0006-20
v	1	valve inside	DN 65 LÖ/FS	3P6008-10
	1	sealing ring	DN 65	3I0113-31
	1	reflux valve	HGL	3P0002-41
		14 Lid		
v	1	lid		3B6300-11
	1	bush	40/50/*20	3K0532-36
	1	lid seal	15*748 45 Shore Silicon	3I0100-62
	1	flange	80*3	3K1016-18
		1432 Lid opening automatic		
	1	cover hood	F. Hydr. Drehzyl./O.B.	3L0019-03
	1	bush	F. Rohrbruchsicherung	3K0530-70
	1	lid axle		3K2401-02
	2	one-way restrictor	3504-RD 1 Verzinkt	3P0002-17
	2	threaded stud	1/4 ZOLL Rohr 10,0	3N4307-17
	2	screw fitting	G 1/4 Rohr 10MM V4A	3N4304-58
	2	screw fitting	G3/8"A GEV-10L-R3/8WD	3N4304-06
	1	hydraulic-motor	DA-H80/90Grad	3H0067-10
	2	Hydraulic tube 225 Bar		3N2050-07
	1	Hydraulic tube 225 Bar		3N2050-08
	1	Hydraulic tube 225 Bar		3N2050-09
	1	Rohrbruchsicherungseinsatz	G 3/8 F. Hydraulik	3P0125-04
	2	Ventilstecker m. Led-u. Kabel	MSUD NR. 3124178 24V	3Q0134-04

Spare parts
List of assembly parts K 729.888

Pos. No.	Qty.	Description	Dimensions	Part No.
		1411 manual		
	2	joint block	BOHR 17/20MM V2A	3L2019-05
	2	disc	21,0x 45,0x 5,0	3K0202-45
	2	locking bolt	M20x145 V4A	3K2572-05
	2	locking toggle	M20	3G0030-02
	4	shank screw	M20*32 ZPF-DM 16,7	3K2040-07
		151-2 Manometer		
v	1	sealing ring g	DN 40	3I0130-06
	1	manometer with 1 contact	-1 - +3BAR R1/2 UNTEN	3P4005-02
	1	grooved nut	DN 40 A2 NR.2003.20	3N4170-06
		1522 Safety valve		
v	1	sealing ring g	DN 40	3I0130-06
v	1	sealing ring g	DN 50	3I0130-07
	1	grooved nut	DN 50 A2 NR.2003	3N4170-07
	1	overpressure safety valve		3P0001-42
		1542 mech. limit switch		
	1	limit switch	GC-U1 RIW	3Q6011-12
		161 Hydraulic		
	1	hydr.-aggr. HST-334-A-1-S/E-02	2*A.2*4/3.1*DOPPELT ENTSPB.RV.	3H0044-36
		17 Pneumatic		
	1	pneumatic service unit	Typ LFR-1/4-D-MINI	3P4340-17
	1	CP valve terminal-A	10P-14-6B-MP-R-Y-6	3P0070-51
		221 Vacuum regulation		
v	1	ball valve	3/4 "	3P1010-05
	2	sealing ring g	DN 40	3I0130-06
	1	grooved nut	DN 40 A2 NR.2003	3N4170-06
	1	pressure transformer	4AP30-010/64	3P4006-01
		27 Vacuum pump		
	1	vacuum pump LEMA25 AZ.FAA.0A.0	350-440V/200-254V50HZ	3H0011-01
	1	pilot valve	spring moved. 3/4	3P0002-35
		411-1 Water counter		
	1	water counter	inductive	3Q2060-15
	1	ball valve	1"	3P1010-06
		423 Lifting and tipping device		
	1	lifting and tipping device		3HP000-30
		42321 Charging wagon		
	1	charging wagon		3E0005-01
		4212 Rotatory pump		
v	1	rotatory pump	FKL 100	3HP000-28
	2	sealing ring G	DN 80	3I0130-09
	2	grooved nut	DN 80	3N4170-09
v	2	sealing ring G	DN 65	3I0130-08
	2	grooved nut	DN 65	3N4170-08
		41 Accessories		
v	1	scraper	13 bores 740*235*85*20	3L5006-10
	1	tube for wrench	610MM LG. F.SW41	3H6004-19
v	1	lid seal	15*748 45SHORE SILICON	3I0100-62
	1	Huelse f. Dichtringmontage	55,1*70*70/PA 6	3K0510-14
	1	Montageschlüssel	F. Messeraufnahme SW 41	3G6019-03
	1	ring spanner	SW 41*215MM LG. Ring-DM 62MM	3H6004-18
	2	hand scrape	Gross m.stiel	3H6000-02
	1	square box spanner	SW19 Ident.-NR. 16275	3H6005-03
	2	cutting edge	R 220 x 8 mit Kullen	3D0041-07

12.3 Hydraulic motors

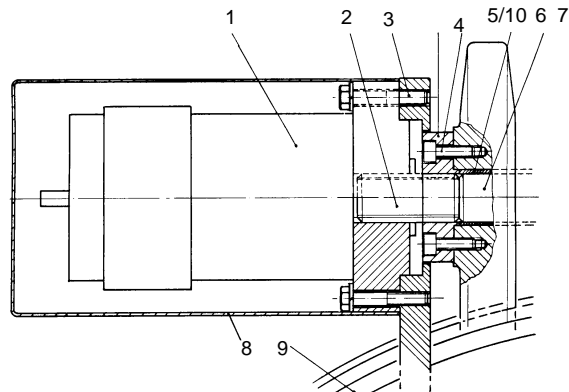

Pos. No.	Qty.	Description	Dimensions	Part No.
1	1	Hydraulic motor of lid hinge		
1	1	Hydraulic motor	DA-H80/90	3H0067-10
2	1	Shaft		
3	6	Hex. screw		
4	1	Flange		
5	3	Socket hat cap screw		
6	1	Bushing		
7	1	Lid hinge		3K2401-02
8	1	Cover		3L0019-03
9	1	Lid		
10	2	Pin		

12.4 Working Inserts

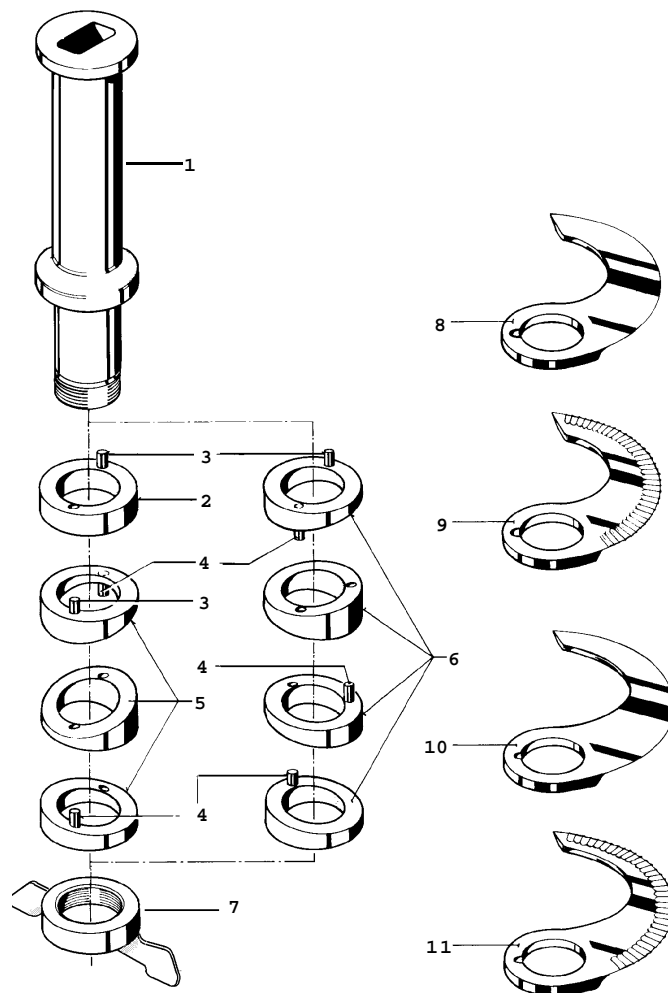

Pos. No.	Qty.	Description	Dimensions	Part No.
1	1	Knife shaft for 2 knives		3D0154-01
2	1**	Pressure ring with pin		3K0311-20
3	2/1*	Connecting pin 8 x 25	SKU60.05-17 T2	3K2035-09
4	2/3*	Connecting pin 8 x 35	SKU60.05-17 T1	3K2035-11
5	1**	Slant-ring set 2-knives, complete with pins		3K0327-01
7	1**	Nut for knife shaft		3K0014-20
8	3	Knife, wide, r= 220 mm		3D0041-07
9	2	Wave cut knife, wide r= 233		3D0041-02
10	2	Knife, small r= 241 mm		3D0040-01
11	3	Wave cut knife, small, r= 241 mm		3D0014-03
w/o ill.	1	Working insert for processed block cheese	4-wing	3d4025-01
w/o ill.	1	Mixing element		3D0042-03

12.5 Discharge valve DN 65

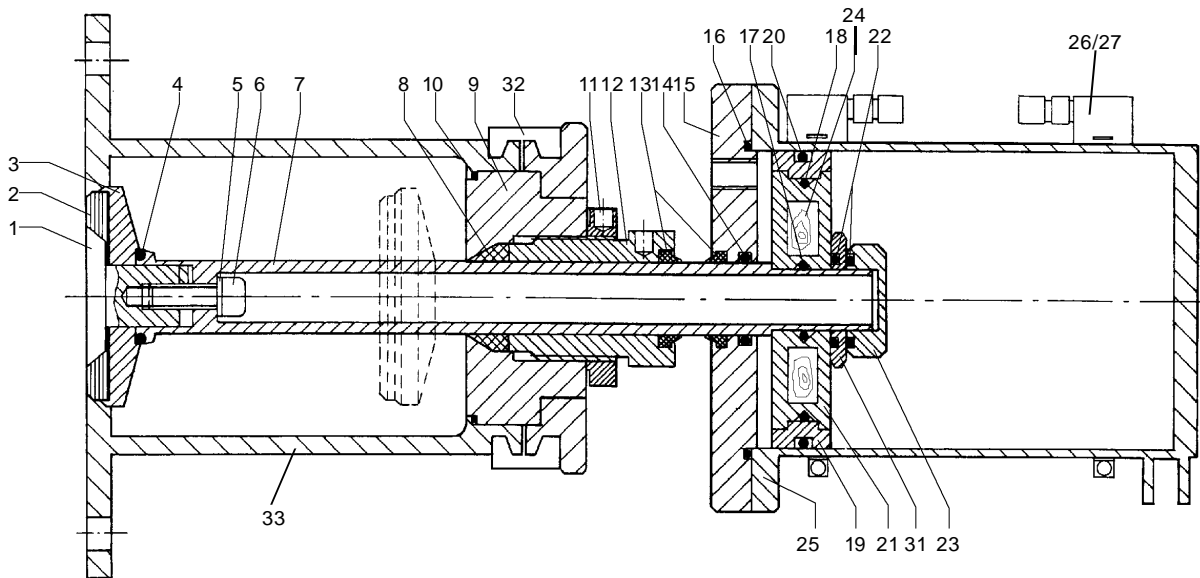

Pos. No.	Qty.	Description	Dimensions	Part No.
1	1	Guide	1.4301	5000.200.341
2	1	Sealing ring	PVDF	5000.200.342
3	1	Sealing plate	1.4301	5000.200.343
4	1	O-ring	EPDM	2304.024.035
5	1	Spring washer	1.4301	8140.008.000
6	1	Socket hat cap screw	1.4301	8095.008.025
7	1	Spindle	1.4301	5000.200.344
8	1	Wiper ring	PTFE	2330.024.615
9	1	Guide	1.4301	5000.200.345
10	1	Sealing ring	PTFE	2353.085.079
11	1	Counter nut	1.4301	5000.200.025
12	1	Adjusting muff	CuZn 40 Pb 2	5000.200.021
13	2	Wiper ring	EPDM	2330.024.007
14	1	O-ring	NBR	2304.024.035
15	1	Flange	1.4301	5000.200.346
16	1	O-ring	NBR	2304.100.030
17	1	O-ring	NBR	2304.019.035
18	1	O-ring	NBR	2304.075.035
19	1	Piston	AL	5000.200.350
20	1	O-ring	NBR	2304.089.045
21	2	Disc	1.4301	5000.200.351
22	2	O-ring	NBR	2304.024.035
23	1	Blind nut	1.4301	5000.200.357-020
24	1	Ring magnet	72x31x10	
25	1	Pneumatic cylinder	1.4301	5000.200.353
26	1	Magnet switch		BIM DKT AP6x HM
27	1	Fixing clip	1.4301	KLA 3

Assembly Group
Discharge valve DN 65

Pos. No.	Qty.	Description	Dimensions	Part No.
28	1	Cable		PK 4T 6
29	4	Nut	1.4301	8115.008.000
30	1	Disc		
31	1	Counter nut	1.4301	5000.200.358-020
32	1	Clamp-ring	DN 80	3N4166-09
33	1	Valve housing	1.4301	3K1350-02
2		Sealing set for discharge valve DN 65 Parts with * are parts of the sealing set		3I0220-16

12.6 Steam nozzle

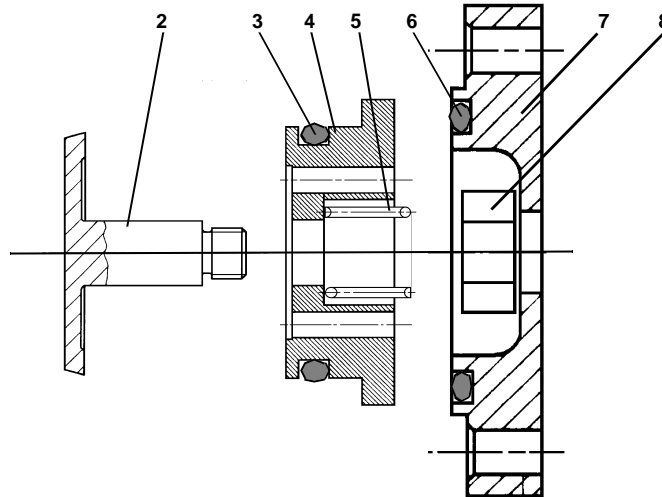

Pos. No.	Qty.	Description	Dimensions	Part No.
1	4	steam nozzle	-	-
2	4	valve head	-	3K2604-07
3	4	o-ring	2-220	3I0021-22
4	4	valve inside	-	3K1307-15
5	4	pressure spring	-	3M6001-13
6	4	o-ring	2-217	3I0006-03
7	4	valve lid	-	3K1330-04
8	4	round nut	-	3K0003-01
8	4	split-pin	2 x 25	3S0262-02
	1	condensate drain, capsule	BP 23 - 1/2"	3H4100-03

12.7 Steam Trap - BP 23-3/4“,

12.7.1 Maintenance

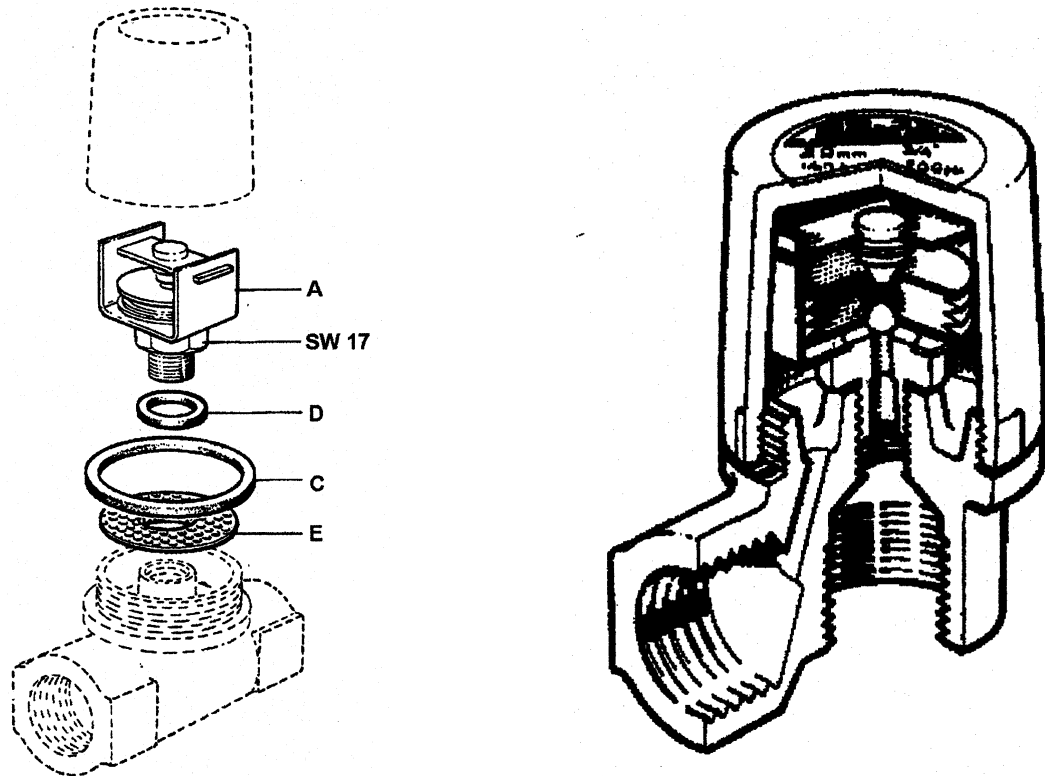

- Types with Y-strainer: Screen to be cleaned periodically.
- For cleaning of trap and screen or replacement of the thermostatic element remove the cover and unscrew the valve assembly using a spanner size 17 mm across flats.
- When replacing the element make sure that all gasket faces are clean. Moisten beginning of the thread with a drop of Loctite No. 40. If necessary fit a new valve seat gasket and a new body/cap gasket.



With the types BP 413 H, BP 423 H and BP 431 H thickness of spanner must not exceed 5 mm so that support plate and clamp holding the capsule are not damaged. Spanner must be kept in a horizontal position.

Pos. No.	Qty.	Description	Dimensions	Part No.
	1	steam trap - BP 23		3H4100-08
A, D	1	steam trap - BP 23	Element-Set	1235.000.102
C, D	1	steam trap - BP 23	Seal Set	1235.000.104
E	1	steam trap - BP 23	Sifter	1237.000.108

12.8 Pressure transducer, type 4 AP-30

1 BESCHREIBUNG

Hinweis :

Alle erforderlichen Einstellungen und evtl. Eingriffe sind in der vorliegenden Betriebsanleitung beschrieben. Sollten trotzdem bei der Inbetriebnahme Schwierigkeiten auftreten, bitten wir Sie, keine unzulässigen Eingriffe an dem Gerät vorzunehmen. — Sie könnten Ihren Garantieanspruch gefährden. Bitte setzen Sie sich mit der nächsten Niederlassung oder dem Stammhaus in Verbindung.

Telefon (06 61) 60 03 - 724

1.1 Allgemeines

Piezoresistive Druckmeßumformer Typ 4 AP-30 werden zur Messung von Drücken in Hydraulik- und Pneumatikanlagen, chemischen und verfahrenstechnischen Anlagen sowie in der Klima- und Umwelttechnik eingesetzt.

Für hochviskose oder kristallisierende Medien, die die Bohrung des Druckanschlusses verstopfen könnten, ist diese Anschlußart nicht geeignet. Hierfür sind Ausführungen mit frontbündiger Membrane im Lieferprogramm.

1.2 Typenerklärung

4 AP-30-010

4	Vertriebsbereich Druckmeßtechnik
A	Aufbaugerät
P	piezoresistiv
-30	Gehäusemaß
-010	Ausgang 0 bis 10 V
-020	Ausgang 0 bis 20 mA
-420	Ausgang 4 bis 20 mA
-242	Ausgang 4 bis 20 mA Zweileiter

1 DESCRIPTION

Important note :

All necessary adjustments and changes (where necessary) are explained in these Operating Instructions. However, if there should be any difficulties in starting up, please do not carry out any prohibited manipulations on the transducer. — You could endanger your rights under the warranty. Please contact the nearest subsidiary or the factory.

international + 49 661 6003-724

1.1 Introduction

Piezo-resistive pressure transducers Type 4 AP-30 are used for the measurement of pressure in hydraulic and pneumatic systems, in chemical and processing plants, and in ventilation and environmental engineering.

This style of connection is not suitable for high-viscosity and crystallising media which could block the bore of the pressure connection. Models with flush front diaphragm are available for such applications.

1.2 Type designation

4 AP-30-010

4	Product group Pressure measurement
A	pipe-mounted
P	piezo-resistive
-30	case dimension
-010	output 0 – 10 V
-020	output 0 – 20 mA
-420	output 4 – 20 mA
-242	output 4 – 20 mA 2-wire

1 DESCRIPTION

Attention :

Au cas où certains passages de cette notice ne vous paraîtraient pas très compréhensibles, veuillez vous mettre en rapport avec nous. Ne pas manipuler l'appareil sans en connaître l'utilisation, au risque de perdre la garantie de l'appareil.

tél: **87.37.53.00**

1.1 Généralités

Les convertisseurs de mesure de pression piezorésistifs type 4 AP-30 sont utilisés pour la mesure de pression d'installations hydrauliques et pneumatiques, dans la chimie, les procédés industriels et dans la climatisation.

Ce type de raccord de pression n'est pas adaptés aux milieux très visqueux ou cristallins, lesquels peuvent boucher le trou du raccord. A cet effet, des exécutions avec membrane affleurante ont été prévues dans notre programme de livraison.

1.2 Explication du type

4 AP-30-010

4	Groupe de pression montage en saillie
A	piezorésistif
P	ø du boîtier
-30	sortie 0 – 10 V
-010	sortie 0 – 20 mA
-020	sortie 4 – 20 mA
-420	sortie 4 – 20 mA
-242	montage 2 fils

1 BESCHREIBUNG

1.5 Technische Daten

Gehäuse

Edelstahl Wst.-Nr. 1.4301

Druckmittelberührte Teile

Edelstahl, Wst.-Nr. 1.4571;

Edelstahlmembrane Wst.-Nr. 1.4401

Druckanschluß

G¹/₂ A nach DIN 16 288

andere Anschlüsse, siehe 2.3

Elektrischer Anschluß

serienmäßig:

Leitungsdose nach DIN 43 650,

Bauform AF,

Leitungsquerschnitt bis max. 1,5 mm²

mit Pg 9-Verschraubung

Typenzusatz /73

4adriges fest angeschlossen, abgeschirmtes PVC-Kabel mit Innenliegendem Luftausgleichsschlauch, Länge 2 m; andere Längen auf Anfrage

Spannungsversorgung U_B

DC 13-30 V serienmäßig

DC 11,6 - 30 V ohne Verpolungsschutz,

auf Anfrage

Restwertigkeit:

Eine über Diodenbrücke gleichgerichtete AC 24 V Spannungsversorgung ist nicht ausreichend. Die Spannungsspitzen dürfen die angegebenen Werte der Spannungsversorgung nicht überschreiten.

max. Stromaufnahme ≤ 30 mA

Spannungsversorgungseinfluß

≤ 0,2% pro 10 V

Ausgang

0 bis 10 V, Bürde ≥ 2 kΩ

0 bis 20 mA, Bürde ≤ $\frac{U_B - 12 V}{0,02 A}$

4 bis 20 mA, Bürde ≤ $\frac{U_B - 12 V}{0,02 A}$

4 bis 20 mA, Bürde ≤ $\frac{U_B - 13 V}{0,02 A}$

Zweileiter

einstellbar über Potentiometer

Nullpunkt: ca. ± 10%

Meßspanne: ca. ± 20%

1 DESCRIPTION

1.5 Technical data

Case

stainless steel, Mat. Ref. 1.4301

Parts in contact with medium

stainless steel, Mat. Ref. 1.4571;

stainless steel diaphragm,

Mat. Ref. 1.4401

Pressure connection

male thread 1/2" pipe to DIN 16 288

other connections, see 2.3

Electrical connection

normally:

terminal box to DIN 43 650, Form AF, with Pg 9 gland up to 1,5mm² conductor cross-section

Extra Code /73:

fixed attached 4-core screened PVC-Cable, with internal air equilibration tubing, 2 m long, other lengths to special order

Supply U_B

normally 13-30 V d.c.

to special order

11.6-30 V d.c. without reverse polarity protection

Residual hum:

The peak voltages must not exceed the values indicated for the power supply.

max. loading 30 mA

Supply voltage error

0,2% max. per 10 V

Output

0 to 10 V, burden 2 kΩ min.

0 to 20 mA, burden $\frac{U_B - 12 V}{0,02 A}$ max.

4 to 20 mA, burden $\frac{U_B - 12 V}{0,02 A}$ max.

4 to 20 mA, burden $\frac{U_B - 13 V}{0,02 A}$ max.

two-wire circuit

Adjustment by potentiometer:

zero: ± 10% approx.

span: ± 20% approx.

1 DESCRIPTION

1.5 Caractéristiques techniques

Boîtier

acier inox AISI 316 Ti

Parties en contact avec le milieu à mesurer

Acier inox AISI 316 Ti; Membrane acier inox AISI 316

Raccord de pression

G¹/₂ A suivant DIN 16 288 autre raccords, voir 2.3

Raccordement électrique

standard:

Prise suivant DIN 43 650, Modèle AF, Section du fil max. 1,5 mm² avec filetage Pe 9

Désignation complémentaire /73:

câble attacher et blindé en PVC à 4 conducteurs avec tuyau pour compensation d'air, longueur 2 m, autres longueurs sur demande

Tension d'alimentation U_B

13-30 V DC (standard) ou en exécution spéciale, 11,6-30 V DC sans protection contre les inversions de polarité Ondulation résiduelle:

Une alimentation 24 V AC redressée par pont de diodes n'est pas suffisante. Les pointes de tension ne doivent pas dépasser les valeurs spécifiées pour la tension d'alimentation.

Puissance absorbée max. ≤ 30 mA

REMARQUE:

Une alimentation 24 V AC redressée par pont de diodes n'est pas suffisante.

Influence d'alimentation

≤ 0,2% par 10 V

Sortie

0 à 10 V, Charge ≥ 2 kΩ

0 à 20 mA, Charge ≤ $\frac{U_B - 12 V}{0,02 A}$

4 à 20 mA, Charge ≤ $\frac{U_B - 12 V}{0,02 A}$

4 à 20 mA, Charge ≤ $\frac{U_B - 13 V}{0,02 A}$

2 fils

Réglage par potentiomètre:

point zéro: env. ± 10%

amplitude de mesure: env. ± 20%

2 MONTAGE

2.1 Montagevorbereitungen

Typenschild prüfen

- ❶ Typenschlüssel
- ❷ Meßbereich
- ❸ Ausgang
- ❹ Spannungsversorgung
- ❺ Geräte-Nr.

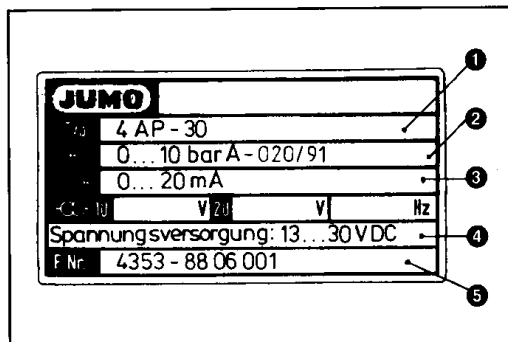

2.2 Montageort

Die Umgebungs- und Mediumtemperatur am Gerät gemessen, muß zwischen -30°C und $+120^{\circ}\text{C}$ liegen (-30°C bis 90°C bei TS/73).

Bitte prüfen Sie bei der Auswahl des Anschlußkabels die Temperaturbeständigkeit.

Achtung!

Beim Einführen von Gegenständen in die Bohrung des Druckanschlusses, kann die Druckmeßzelle beschädigt werden.

2.3 Abmessungen

4 AP-30

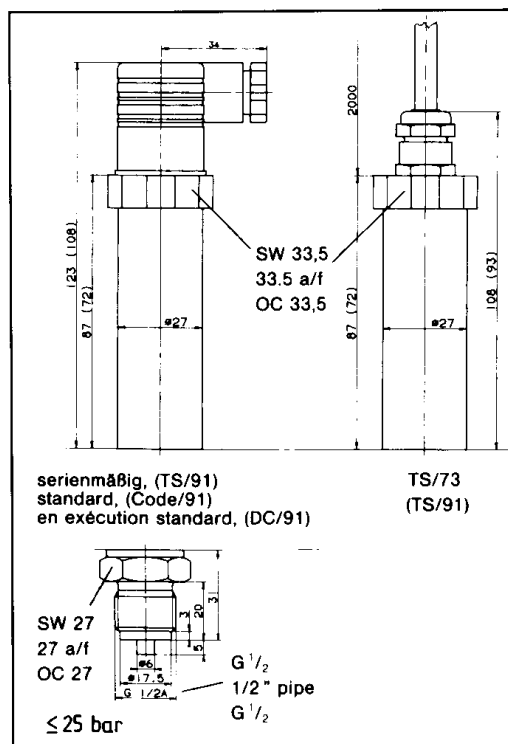

2 INSTALLATION

2.1 Preparation for installation

Check the label

- ❶ Type designation
- ❷ Range
- ❸ Output
- ❹ Supply
- ❺ Serial No.

2.2 Instrument location

The ambient temperature and the temperature of the medium, measured at the transducer, must be between -30 and $+120^{\circ}\text{C}$ (-30°C and $+90^{\circ}\text{C}$ Code /73). When selecting the connecting cable please check it for its operating temperature.

Important!

Inserting any object into the bore of the pressure connection may damage the pressure cell.

2.3 Dimensions

4 AP-30

MONTAGE

2.1 Préparation du montage

Contrôler la plaque signalétique

- ❶ Type
- ❷ Etendue de mesure
- ❸ Sortie
- ❹ Tension
- ❺ N° de l'appareil

2.2 Lieu de l'installation

La température ambiante et du milieu au niveau de l'appareil doit être comprise entre -30 et $+120^{\circ}\text{C}$ (-30°C et $+90^{\circ}\text{C}$ à DC/73). Lors du choix du câble de raccordement, en contrôler la tenue en température.

Attention!

Veiller à ce qu'aucun corps étranger ne pénètre dans le trou du raccord de pression au risque d'endommager la cellule de mesure.

2.3 Encombrements

4 AP-30

Attention!

En cas d'utilisation de robinet d'isolement, utiliser de préférence un robinet à ouverture progressive.

Si un robinet à boisseau sphérique ou $1/4$ de tour est utilisé, ouvrir très lentement cet organe afin d'éviter tout coup de bélier.

2 MONTAGE

2.5 Anschlußplan

Anschluß		Anschlußbelegung	
		Stecker	Kabel
Spannungsversorg. DC 13-30V		1 = L + 2 = L -	weiß grau
Ausgang 0-10 V		2 = - 3 = +	grau gelb
Ausgang 0-20 mA		2 = - 3 = +	grau gelb
Ausgang 4-20 mA		2 = - 3 = +	grau gelb
Ausgang Zweileiter		in Spannungsversorgung Eingeprägter Strom 4 - 20 mA	
Schutzleiter			
Abschirmung			schwarz

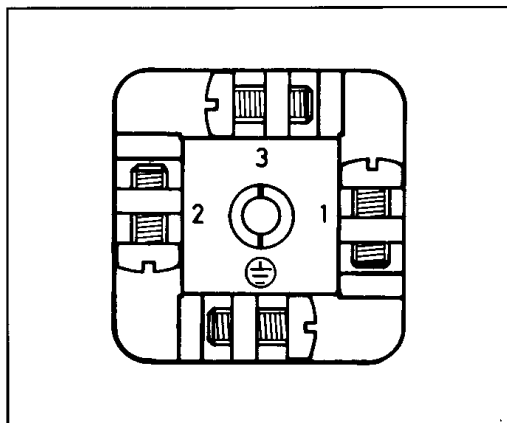

2.6 Anschlußschema

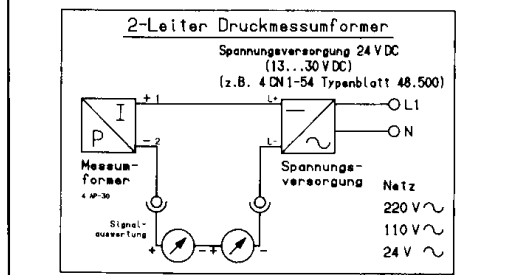
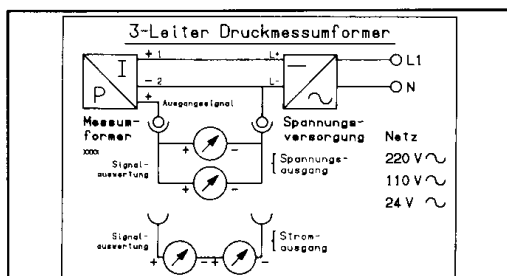

2.7 Elektrischer Anschluß

Achtung:

Schutzleiter oder Abschirmung unbedingt an Erdpotential anschließen!

Der Außendurchmesser der Anschlußleitung muß zwischen 4,5 bis 7 mm liegen.

Leitungsdose nach DIN 43 650, Bauform AF mit Pg9-Verschraubung, Leitungsquerschnitt bis max. 1,5 mm², Schutzart IP65.

Zum Öffnen des Steckers, Schraube ① herausdrehen. Mit schmalen, flachem Schraubendreher, Innenteil ③ aus dem Außenteil ② heraushebeln (siehe Markierung am Innenteil). Das Innenteil kann beim Zusammenbau beliebig in 90°-Schritten in das Außenteil eingesetzt werden.

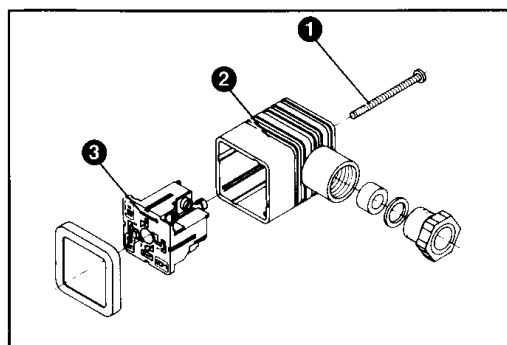

2 INSTALLATION

MONTAGE

2.5 Connection diagram

Connection for	Terminals	Connector	Cable
Supply 13-30 V d.c.	1 = L + 2 = L -		white grey
Output 0-10V	2 = - 3 = +		grey yellow
Output 0-20 mA	2 = - 3 = +		grey yellow
Output 4-20 mA	2 = - 3 = +		grey yellow
output Two-wire circuit	in Supply Current 4 to 20 mA		
Protectiv ground			
Screen			black

2.5 Schéma de raccordement

Raccord	Position des contacts	Fiche	câble
Tension d'alimen. 13-30 V DC	1 = L + 2 = L -		blanc gris
Sortie 0-10 V	2 = - 3 = +		gris jaune
Sortie 0-20 mA	2 = - 3 = +		gris jaune
Sortie 4-20 mA	2 = - 3 = +		gris jaune
Sortie 2 fils	dans la bouche d'alimentation Courant contraint 4 - 20 mA		
Masse			
Blindage			noir

2.6 Connection diagram

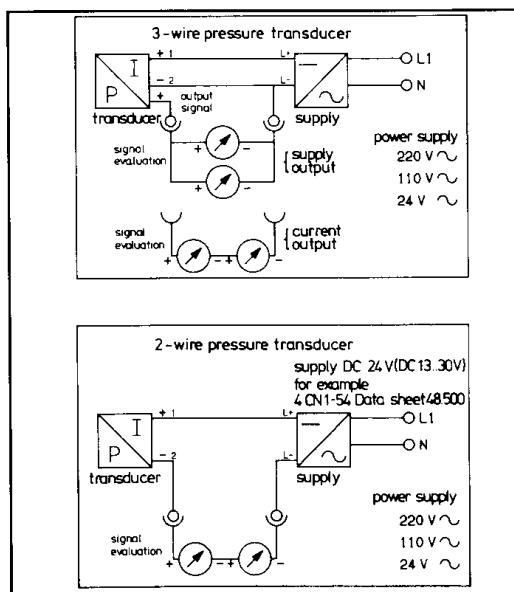

2.6 Schéma de raccordement

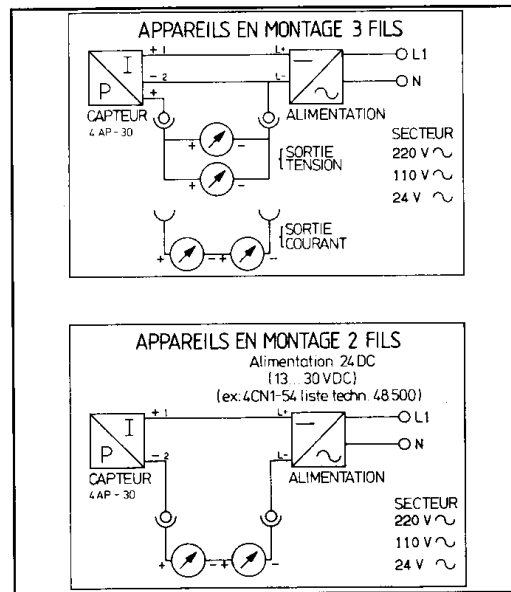

2.7 Electrical connection

Terminal box to DIN 43 650, Form AF, with Pg 9 cable gland, conductor cross-section up to 1.5 mm², Protection IP 65.

2.7 Raccordement électrique

Prise suivant DIN 43 650, modèle AF avec filetage Pe 9, section de fil 1,5 mm² max., mode de protection IP 65.

3 INBETRIEBNAHME

3.1 Druckbeaufschlagung

Um Druckspitzen zu vermeiden, ist der Druckmeßumformer langsam mit Druck zu beaufschlagen.

Überlastungsgrenze (siehe 1.5) beachten!

3.2 Funktionsprüfung

Spannungsversorgung einschalten. Das Ausgangssignal des Druckmeßumformers muß mit den Daten des beiliegenden Prüf- und Justierprotokolls übereinstimmen. Bei Abweichung muß der Druckmeßumformer neu abgeglichen werden, siehe Punkt 3.3.

3.3 Abgleich

Achtung:

Der Abgleich ist nur mit einem Vergleichsdruckmeßgerät möglich.

Zur Anpassung an Anzeige-, Regel- und Registriergeräte können Nullpunkt und Meßspanne über zwei Potentiometer im Elektronikteil verändert werden. Hierzu ist die Überwurfmutter ① des Gerätesteckers abzuschrauben.

Anschließend mit einem Schraubendreher durch die Vergußmasse ② zum gekennzeichneten Potentiometer durchstechen. Nach durchgeführter Korrektur schließt sich die Vergußmasse von selbst.

③ $\left| -0 - \right|$ Nullpunkt ca. $\pm 5\%$

④  Meßspanne ca. $\pm 5\%$

Vor dem Abgleichvorgang muß das Gerät seine Betriebstemperatur erreicht haben (ca. 30 Min. Betriebsdauer).

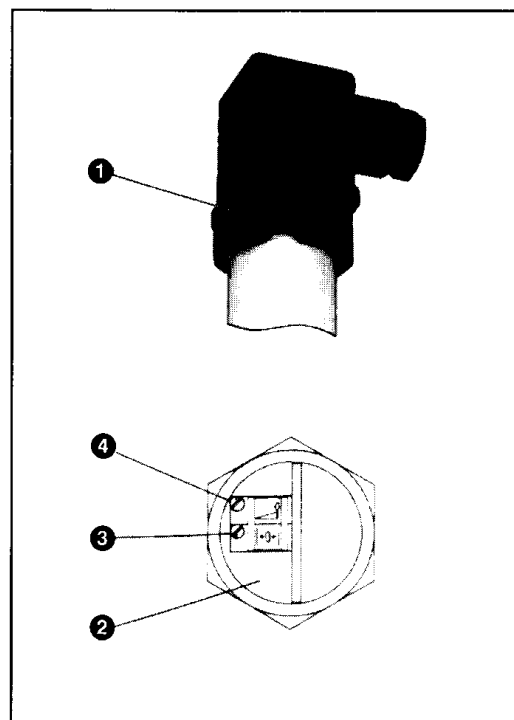

3 STARTING UP

3.1 Applying pressure

Pressure must be applied slowly to the pressure transducer in order to avoid pressure surges. Note the load limit (see Section 1.5)!

3.2 Functional test

Switch on supply. The output signal of the pressure transducer must agree with the data on the enclosed test and calibration certificate.

In case of any deviations the transducer must be recalibrated, see Section 3.3.

3.3 Calibration

Important:

The calibration can only be carried out using a pressure calibrator.

Zero and span can be changed with two potentiometers in the electronics to suit indicators, controllers and recorders. For this operation the loose nut ❶ of the plug must be unscrewed.

Then push a screwdriver through the potting compound ❷ to reach the marked potentiometer.

After the adjustment has been made the hole in the compound closes itself.

❸  Zero ±5% approx.

❹  Span ±5% approx.

Before carrying out this adjustment the transducer should have reached its operating temperature (approx. 30 min. operation).

3 MISE EN SERVICE

3.1 Mise sous pression

Afin d'éviter les pointes de pression, il faut veiller à ce que le convertisseur de mesure de pression puisse être mis lentement sous pression. Attention à la charge limite (voir point 1.5)!

3.2 Contrôle du fonctionnement

Mettre l'appareil sous tension. Le signal de sortie du convertisseur de mesure de pression doit correspondre aux caractéristiques données par le certificat de contrôle et d'étalonnage. Dans le cas contraire, il faut que le convertisseur soit à nouveau taré (voir point 3.3.).

3.3 Tarage

Attention:

Ce tarage n'est possible qu'avec un appareil de mesure de pression comparative.

Pour adapter le convertisseur à des indicateurs, régulateurs ou enregistreurs, le point zéro et l'amplitude de mesure peuvent être modifiés à l'aide de deux potentiomètres dans la partie électronique. Il faut dévisser l'écrou femelle ❶ du connecteur et à l'aide d'un tournevis percer la masse de scellement ❷ pour atteindre le potentiomètre déterminé. La correction du zéro effectuée, la masse de scellement se referme d'elle-même. Une correction de l'amplitude de mesure peut être effectuée de la même façon.

❸  Point zéro env. ±5%

❹  Amplitude de mesure ±5%

Avant d'effectuer ce tarage, il est nécessaire que l'appareil ait atteint sa température de service (env. 30 min. de fonctionnement).

4 WARTUNG / STÖRUNG

Die Geräte sind wartungsfrei. Im Falle einer Störung senden Sie bitte das Gerät mit genauer Fehlerangabe an die Lieferfirma zurück.

Die Mitarbeiter in unseren Außenbüros, Niederlassungen und Vertretungen stehen Ihnen jederzeit mit Beratungen und Service zur Verfügung.

Umrechnungstabelle

mm	inch	bar	psi	psi	bar
2.5	0.10	0,25	3,63	4	0,28
2.85	0.11				
3	0.12	0,4	5,80	6	0,41
5	0.20				
6	0.24	0,6	8,70	10	0,69
15	0.59				
16	0.63	1,0	14,50	15	1,04
17.5	0.69				
20	0.79	1,6	23,20	25	1,73
26.2	1.03				
27	1.06	2,5	36,25	40	2,76
28	1.10				
31	1.22	4	58,0	60	4,14
32	1.26				
34	1.34	6	87,0	90	6,21
35	1.38				
40	1.57	10	145,0	150	10,35
43.5	1.71				
46	1.81	16	232,0	250	17,25
50.5	1.99				
55	2.17	25	362,5	400	27,6
63	2.48				
72	2.83	40	580	600	41,4
87	3.43				
93	3.66	60	870	900	62,1
108	4.25				
123	4.84	100	1450	1500	103,5
2000	6.7 ft				
1.5 mm ²	0.0024 in ²				

4 MAINTENANCE / FAULTS 4 ENTRETIEN / PANNE

The transducer does not require any maintenance. In case of a fault please return it to the supplier with full details of the fault.

The staff of our Technical Offices, Subsidiaries and Representatives will be pleased to provide assistance and to service your instrument.

Ces appareils ne demandent aucun entretien. En cas de panne, renvoyez le convertisseur à votre fournisseur, en précisant bien quel est le défaut constaté.

Nos services commerciaux et agents extérieurs se tiennent à votre entière disposition pour tous les renseignements techniques que vous jugerez utiles.

Pos. No.	Qty.	Description	Dimensions	Part No.
1	1	Pressure transducer	4AP30-010/64, -1 bis 1,5 bar	3P4006-01
2	1	Pressure transducer	4AP30-242/64, -1 bis 1,5 bar	3P4006-04
3	1	Pressure transducer	4AP30-020, 0 bis +6 bar	3P4006-05
4	1	Pressure transducer	4AP30-420, 0 bis 10 bar	3P4006-09
5	1	Pressure transducer	4AP30-242, 0 bis 10 bar	3P4006-10
6	1	Pressure transducer	4AP30-242/64, -1 bis +3 bar	3P4006-16



When ordering, please give us the position no. and the nominal with (DN...)!

12.9 Hydraulic

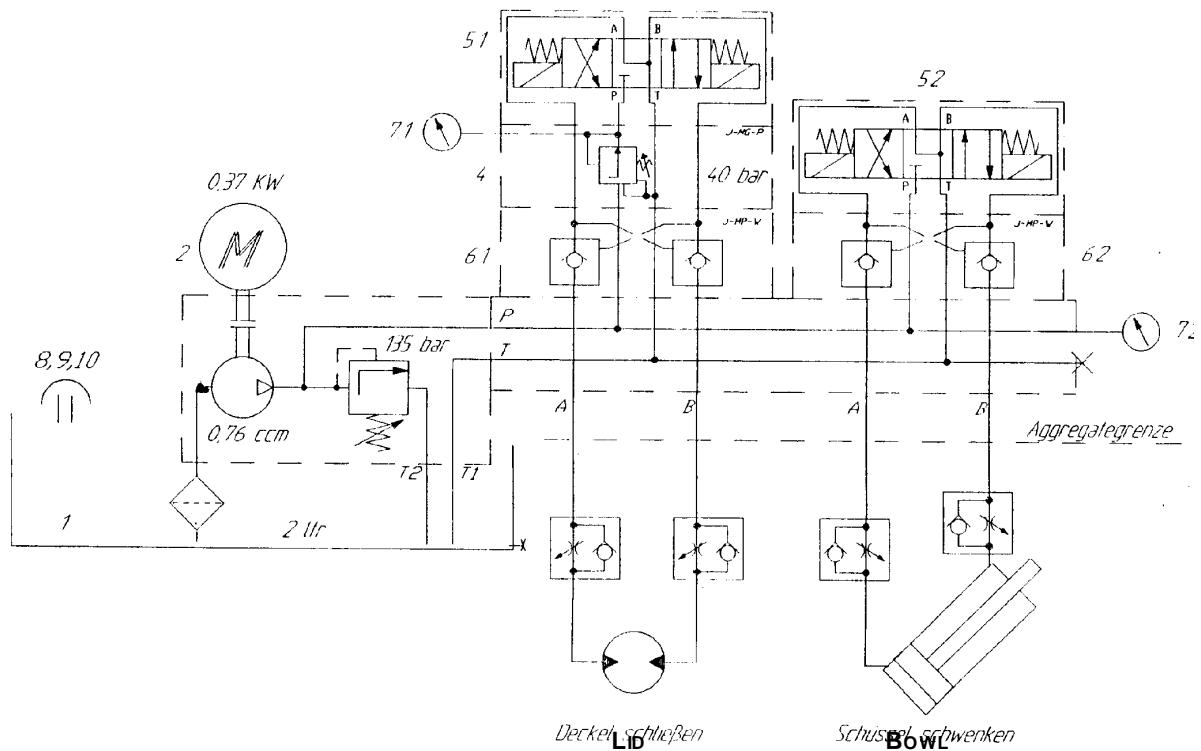

Pos. No.	Qty.	Description	Dimensions	Part No.
		Type of equipment: HST-334-A-1-E-00		3H0044-36
1	1	Compact aggregate inc. 2 Ltr. Tank, pressure control valve, control up to 200 bar, pump 0,76 ccm	MC4-AD-V1B-PD-ML-T02-F1	
2	1	E-Motor, 0,37 kW, B14k, IP 55, 71		
3	1	pilot controlled check valve, Zw.PI.,NG 6	J-MP-02A-20-60	
4	1	Pressure regulation valve, Zw. PI., NG 6	J-MG-02A-2-60	
5	2	4/3-Way-valve NG 6	J-KSO-G02-4C-10	
6	1	pilot controlled check valve, Zw.PI.,NG 6	J-MP-02W-20-60	
7	2	Manometer	63, 0-250 bar	
8	1	Screwed filter G 1/2	UC-SAB-6101	
9	1	Level plunger	UC-DIP-206	
10	1	Valve extension G 1/2	25 lang	
11	2	Coupler socket A	Grau	
12	2	Coupler socket B	Schwarz	
13	4	Socket head cap screw	M5 x 85 DIN 912	
14	4	Socket head cap screw	M5 x 125 DIN 912	

12.10 Safety valve Series - 96

12.10.1 General Notes

Safety valves are high-quality fittings which should be handled with special care.

The contact surfaces are microfinished at the seat and cone, thereby achieving the necessary imperviousness.

The penetration of foreign bodies into the valve during assembly or operation should be avoided. The imperviousness of the safety valve can be impaired by hemp, Teflon band, welding beads etc. If the safety valves are given a coat of paint, it should be ensured that moving parts are not brought into contact with the paint.

12.10.2 Installation and assembly

Spring safety valves should be installed with perpendicularly standing spring cap.

In order to guarantee the perfect functioning of the safety valves, they should be mounted in such a way that no unacceptable static, dynamic, or thermal stress can be placed on the safety valve.

Condensate trapping

If development of condensate is possible, the pipelines should be equipped with a continuously working device for condensate education at their lowest point. It should be ensured that the condensate or escaping medium is educated safely.

The casing, pipelines and sound absorbers should be protected against freezing.

Inlet line

The inlet socket for the safety valves should be as short as possible and should be formed in such a way that pressure losses in excess of 3% of the set pressure at full valve output are not possible.

Outlet line / Back pressure

The outlet line for safety valves without bellows should be designed in such a way that the necessary mass flow can be educated unpressurized during blowing off.

For safety valves with bellows (TRD 721), a back pressure of up to maximum of 4 bar during blowing off does not impair the set pressure of the safety valve.

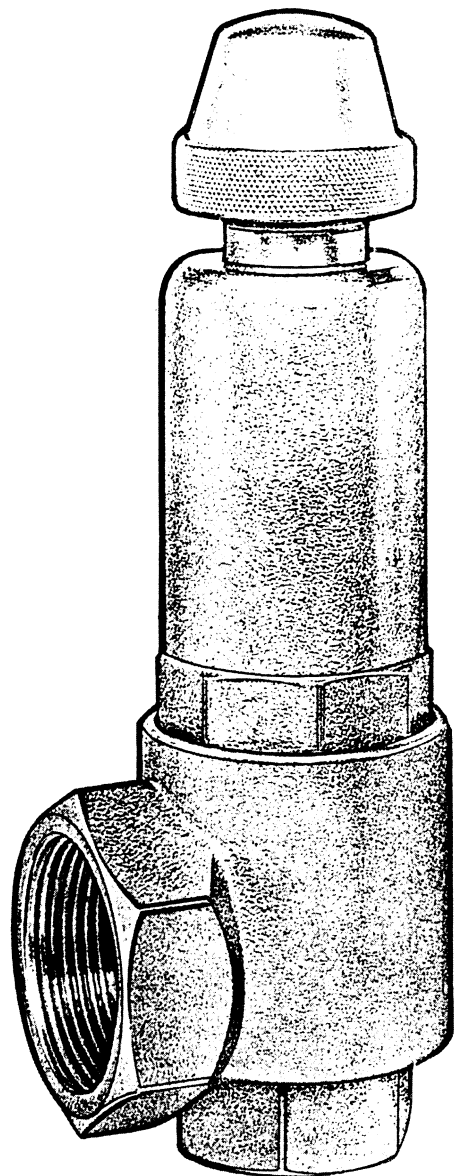

12.10.3 Testing / Marking

The safety valves are tested, adjusted for demanded set pressure and leaded by us.
The set pressure is imprinted on the bonnet (spring cap).

without bellows

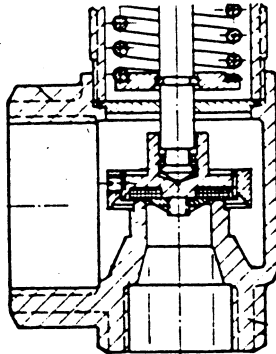

with bellows

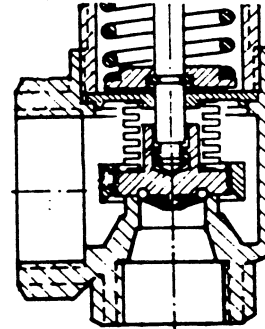

12.10.4 Operation / Maintenance

The working pressure of the system should lie at least 5% under the reseating pressure of the safety valve. It is thus ensured that the safety valve can close again freely after blowing off. The valve can be made to blow-off by being lifted up for cleaning in case of small leakages which can be caused by contamination between the contact surfaces.

For safety valves without bellows any deposits on the seat and seat seal can also be removed by unscrewing the bonnet with a suitable wrench (not pipe wrench).

The set pressure of the safety valve is not altered by screwing in the bonnet to the casing.

The bonnet should not be separated from the casing for safety valves with bellows, as then impervious-ness at back pressure can no longer be guaranteed. Cleaning is carried out by lifting up the safety valve. If the leakage cannot be thus eliminated, the contact surface is probably damaged, this can be repaired only in our works or by authorised specialists. Safety valves with bellows have a relief well in the spring cap. If the medium escapes from this well, the safety valve is defective. The safety valve should be overhauled.

It is recommended and is also required according to the relevant regulations to cause the safety valve to blow off from time to time by lifting up in order to check the good functioning of the safety valve.

According to TRD 601 the safety valves on steam generators should be checked for working at least every 4 weeks.

Safety valves provide the last safety device for the container. They should be capable of preventing an inadmissible gauge pressure even if all other previous regulation, control and monitoring devices have failed. In order to ensure this reliability, safety valves, like all other technical devices, require maintenance.

Pos. No.	Qty.	Description	Dimensions	Part No.
1	1	Saftey valve Series - 96	DN15 0,5bar Z96-851-T	3P0001-02
2	1	Saftey valve Series - 96	DN15 1,5bar Z96-851-T	3P0001-03
3	1	Saftey valve Series - 96	DN15 2,0bar Z96-851-T	3P0001-04
4	1	Saftey valve Series - 96	R1/2" 3,5bar Z96-851-T	3P0001-05
5	1	Saftey valve Series - 96	R3/4" 0,5bar Z96-851-T	3P0001-07
6	1	Saftey valve Series - 96	DN20 2,0bar Z96-851-T	3P0001-08
7	1	Saftey valve Series - 96	DN32 4,0bar Z96-851-T	3P0001-10
8	1	Saftey valve Series - 96	DN32 0,5bar Z96-851-T	3P0001-11
9	1	Saftey valve Series - 96	DN32 2,0bar Z96-851-T	3P0001-12
10	1	Saftey valve Series - 96	R3/4" 0,9bar Z96-851-T	3P0001-26



When ordering, please give us the position no. and the nomonal with (DN...)!

12.11 Safety valve type 718 - DN 40/50 0.1 bar

Order No.: 3P0001-42

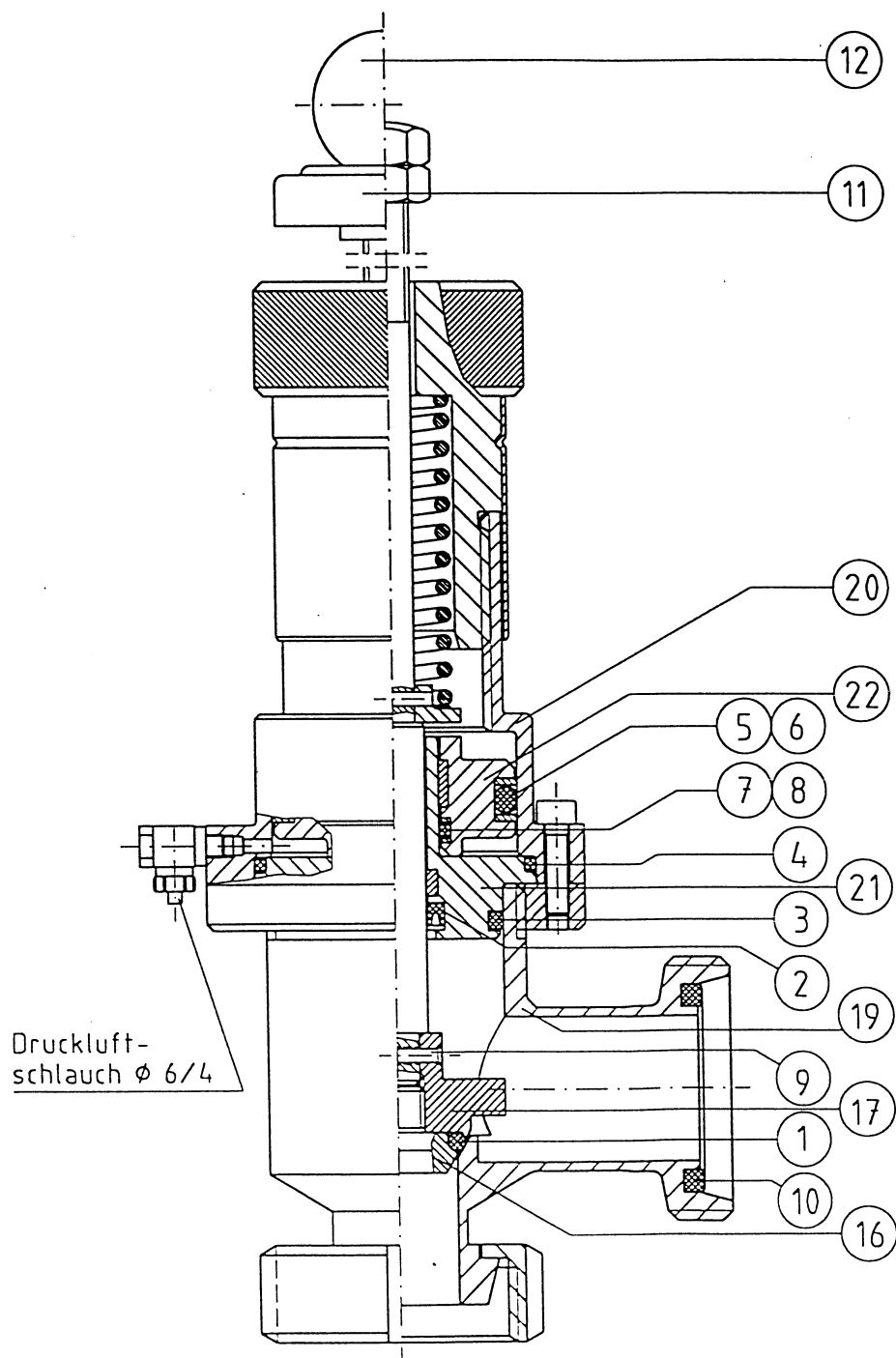

12.11.1 Operation and Maintenance of safety valve type 718D

Operation and maintenance

- To check proper functioning, ventilate valve cone (16) from time to time pneumatically.
- Clean safety valve regularly.
- For the necessary air pressure, see diagram (control air for drive cylinder).
- Protect safety valve from external forces, each damage impairs the functioning.
- The adjustment of the set pressure > factory setting is done by twisting the top part.
- For normal operation, part (11) is screwed against part (12).

Steuerluft für Antriebszylinder (ohne Betriebsdruck am SV)

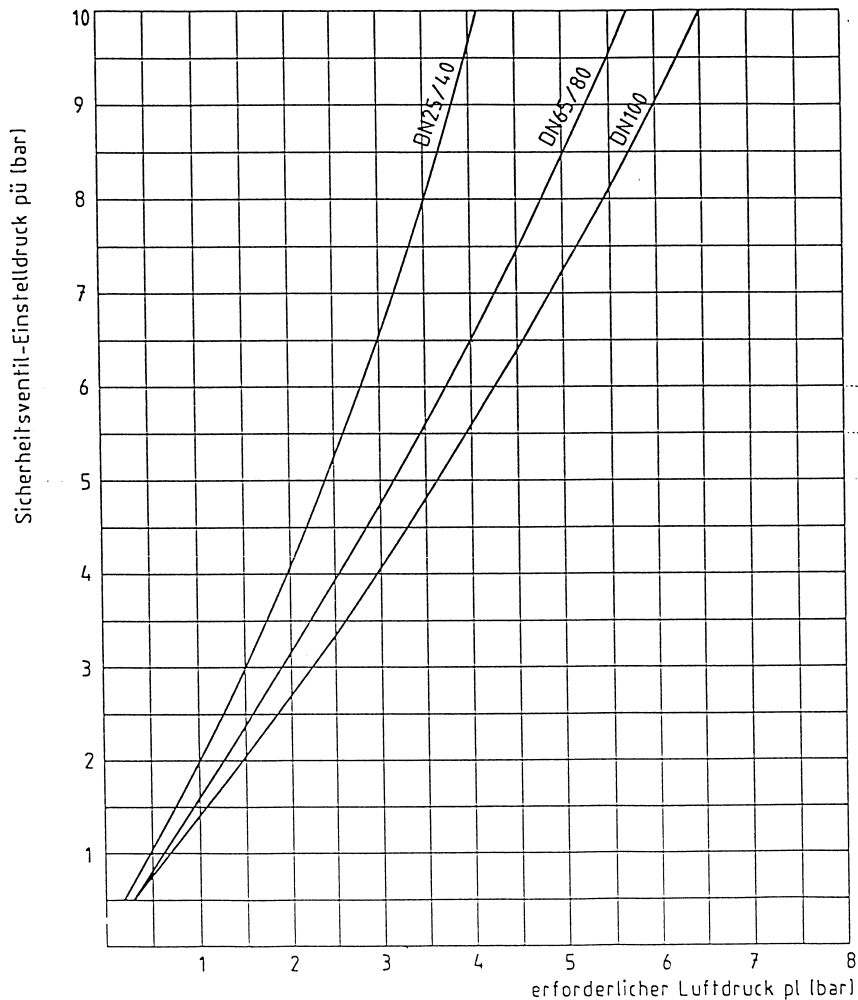

Replacing parts

- Carry out work diligently, and prevent damage.
- Detach complete top part (23) from case (24).
- When working on several safety valves, do not interchange parts.



Observe spring tension!

Exchange O-ring (1)

- Unscrew bottom part of valve cone (16).
- Exchange O-ring (1) (do not twist, clean only).

Replacing parts (2-8)

- Remove dowell pin (9) and parts (17/21/22).
- Replacing parts (2-8)



Observe installation position of (2)!
Clean lining grooves!

- Install complete top part.
- Re-install valve cone (9/16/17).



Use screw retention liquid - e.g. Loctite 221.

Install safety valve

- Connect complete top part (23) with case (24) by screw.



Südmob Components GmbH
D - 73469 Riesburg - Germany

Ersatzteilliste / List of spare parts

Sicherheitsventil mit pneum. Anhebevorrichtung, federbelastet, bauteilgeprüft – Dämpfe/Gase
Safety valve with pneumatic lifting device, spring loaded, approved by TÜV for steam/gas

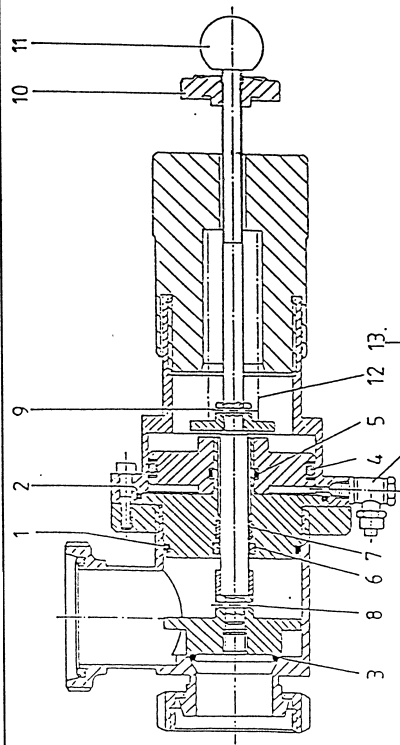

- * Bei Ersatzteilbestellung von Pos. 12 (Druckfeder) wird der auf dem Ventil angegebene Abblasedruck immer benötigt
- * When ordering pos. 12 (compression spring) please indicate corresponding blow-off pressure of valve

Abweichende Werkstoffe der Dichtelemente bei Bestellung angeben bzw. auf Anfrage
Alternative materials of seals upon request.

Pos.	Stück Piece	Benennung Denomination	Werkstoff Material	DN 25		DN 40	
				Best.-Nr. Order no.	Abmessung Dimension	Best.-Nr. Order no.	Abmessung Dimension
1	1	O-Ring / O-ring	NBR	0808951002	Di 40 x 4	0808951004	Di 60 x 4
2	1	O-Ring / O-ring	NBR	0808951019	Di 55 x 3	0808951035	Di 88 x 4
3	1	O-Ring / O-ring	NBR	0808951028	Di 21 x 4	0808951003	Di 36 x 4
4	1	O-Ring / O-ring	NBR	0808951018	Di 44,2 x 5,7	0808952004	Di 74,2 x 5,7
5	1	O-Ring / O-ring	NBR	0808951020	Di 20,2 x 3	0808951020	Di 20,2 x 3
6	1	Innenlippeabdichtung / Compression seal	NBR	0808951012	22 x 14 x 5	0808951012	22 x 14 x 5
7	1	Lagerbuchse / Bearing bushing	PTFE	-----	-----	0808951027	-----
8	1	Spiralspannstift / Locking pin	1.4301	0808951030	N 3 x 18	0808951030	N 3 x 18
9	1	Spiralspannstift / Locking pin	1.4301	0808951016	N 3 x 20	0808951030	N 3 x 18
10	1	Sterngriff / Grip for clamp screw	Duroplast	0808951023	ø50 / M 10	0808951022	ø50 / M 10
11	1	Kugelknopf / Control lever knob	Duroplast	0808951023	ø32 / M 10	0808951023	ø32 / M 10
12	1	Druckfeder / Compression spring	1.4301	0808951.....	*	0808951.....	*
13	1	Einlaßdrossel / Inlet throttle		0864003990	451-M5-6/4	0864003759	482-1/8"-02

Abblasemenge

Sicherheitsventil (federbelastet)

Medium: Luft (bei CO₂: Multiplikator 0,78)

Temperatur: max. 120°C

$\Delta P = 10\%$ (< 1 bar: $\Delta P = 0,1$ bar)

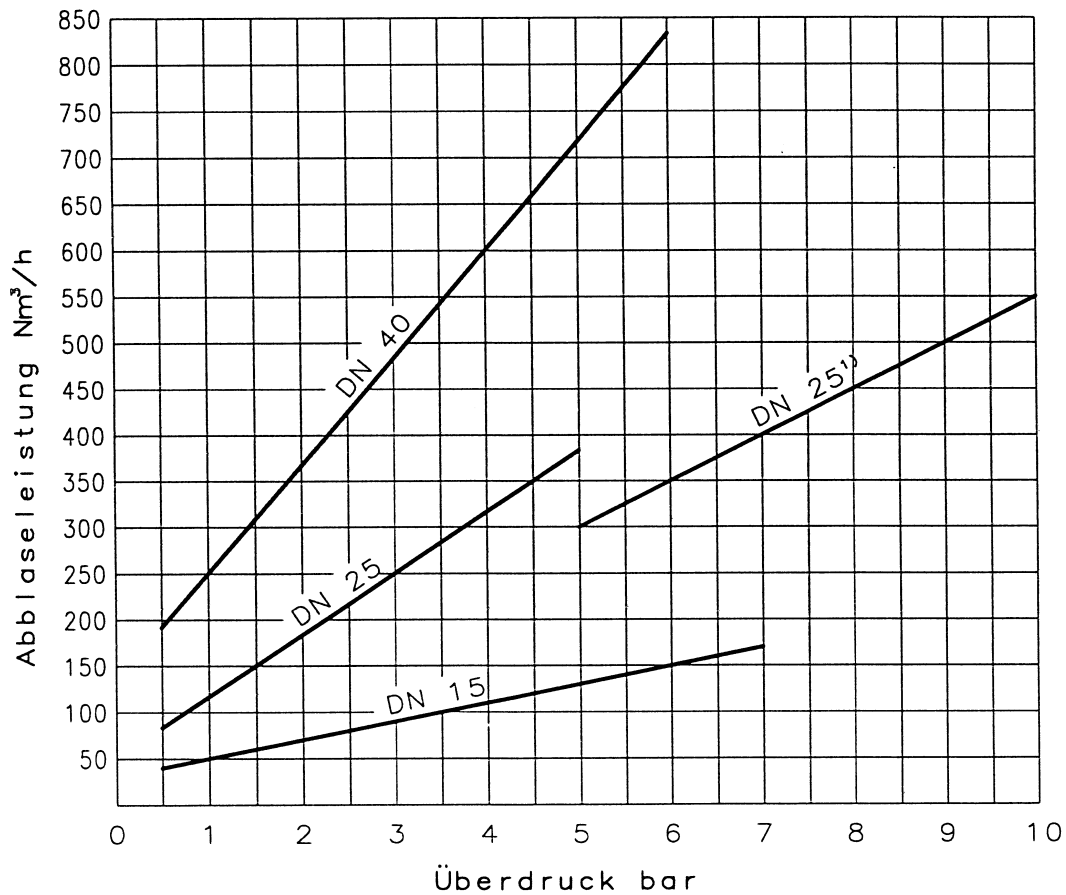

TÜV-Bauteilkennzeichen

- DN 15 TÜV . SV . 94 – 845 . 15 . D/G . 0,18 . p
- 1) DN 25 TÜV . SV . 94 – 745 . 26 . D/G . 0,14 . p
- DN 25 TÜV . SV . 94 – 744 . 26 . D/G . 0,18 . p
- DN 40 TÜV . SV . 94 – 743 . 38,5 . D/G . 0,15 . p

12.12 CP Valve terminal



Pos. No.	Qty.	Description	Dimensions	Part No.
	1	1 CP Valve terminal-A.	10P-14-4B-MP-R-Y-4C	3P0070-50
	2	1 CP Valve terminal-A.	10P-14-6B-MP-R-Y-6C	3P0070-51
	3	1 CP Valve terminal-A.	10P-14-8B-MP-R-Y-8C	3P0070-52



When ordering, please give us the position no., dimensions and the part no. !

12.12.1 Technical specifications

Technical specifications CP valve terminal type 10	
Ansteuerungsspannung	DC +24V + 10%/-15% (20,4-26,4V)
Abfallstrom der Ventile	> 2mA
Protection class as per EN 60 529	IP 65
Tightening torques - Befestigungsschrauben der Anschlußplatte - Multipoldose	- 1,0 + 0,2 Nm - 0,6 Nm
Materials (Plates, cover, pneumatic multiple connector plate: seal:	AL, AL-GD, Ms, PAXMD6, PET, POM, PPS, ST, NBR, HNBR



Operate the CP valve terminal only with the medium described below.

- If possible, use non-lubricated auxiliary pilot air (connection 12/14). Otherwise the oil content must not exceed 3-5 drops per 1000 l of air consumed. Use hydraulic oil of type DIN 51524-HLP32. Observe the instructions on special oil for maintenance units.
- In the case of CP valve terminals with internally branched auxiliary pilot air, the above mentioned instruction also applies to the supply air (connection 1/11).

12.12.2 Checking the valve functions

Manual override

You should use the manual override principally when commissioning the pneumatic system, in order to check the functioning and effectiveness of the valve or valve-cylinder combination.

By actuating the manual override, you can switch the valve without an electrical signal. Only the compressed air supply need be switched on.



Before operating the manual override:

Disconnect the operating voltage supply to the valve solenoid coils by unplugging the contact (IC, MP AS-i or CP connection). You then avoid undesired actuation of the valve solenoid coils.



Before applying the operating voltage:

Make sure that all manual overrides are set again at their basic positions. You then avoid undefined switching states of the valves.

The manual override is intended for use as follows:

Manual override design	Mode of operation
Manual override with automatic reset (pushing)	Manual override is reset by spring force.
Manual override locking	Manual override remains active, until it is reset by hand.

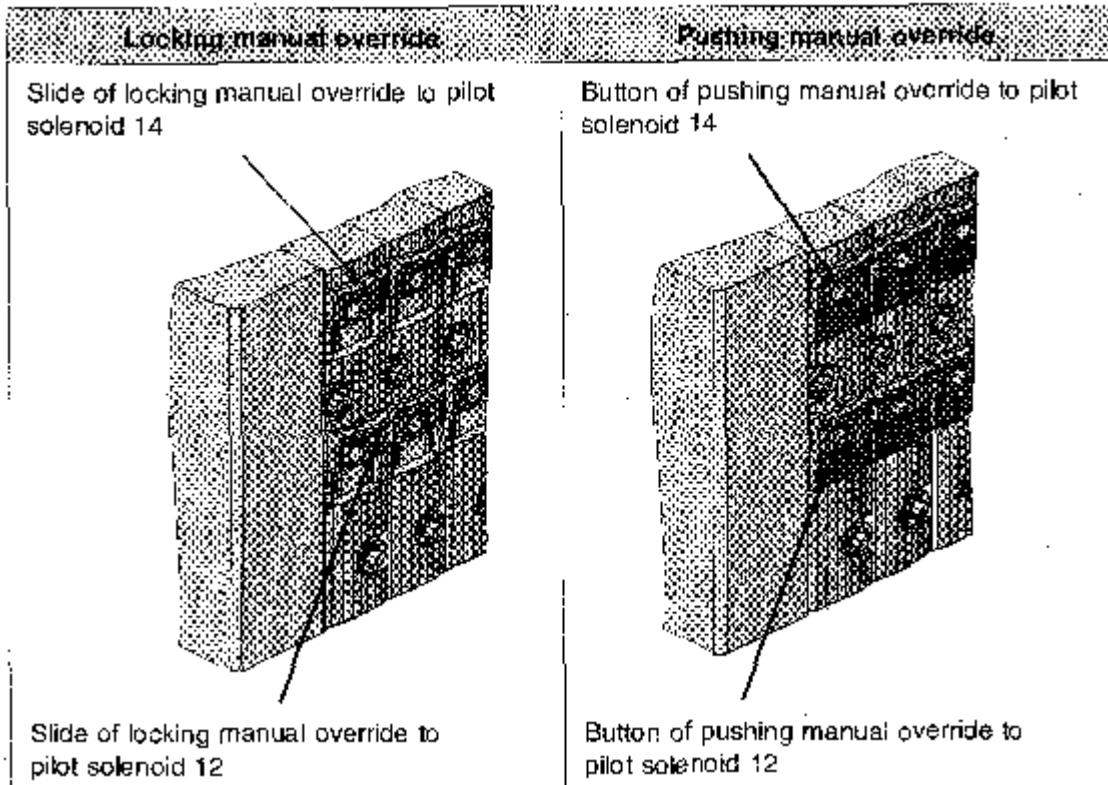

When exhausting or repressurizing the valve terminal under the following conditions:

- with safety start-up valve (slow pressure build-up) and
- when there is an electrical signal (e.g. after EMERGENCY STOP) Supply the auxiliary pilot air separately (3 to 8 bar).

The auxiliary pilot air must reach its full level immediately after being switched on, otherwise the slow pressure build-up of the overall supply will have no effect with cylinders actuated as follows:

- by means of single solenoid valves
- by means of double solenoid valves which are switched to flow-through during the pressure-less phase.

The effects of slow pressure build-up when there is an electrical signal are shown in the table below.

Separately supplied auxiliary pilot air	Pressure increase in overall supply	Pressure increase in auxiliary pilot air (12/14)	Moment when valve switches over	Movement of cylinder
taken behind safety start-up valve	slow	slow	after pressure increase at (1)	fast
taken in front of safety start-up valve	slow	fast	before pressure increase at (1)	slow



Use a blunt pointed object for actuating the pushing manual override.
Actuate the manual override with max. 30N.
You thereby avoid functional interference or damage to the manual override.

Proceed as follows:

- Switch on the compressed air supply.
- Check the functioning and mode of operation of each individual valve cylinder combination with the manual override as shown in the diagrams below.
- When the test is finished, switch off the compressed air supply again..

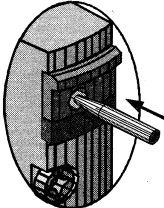
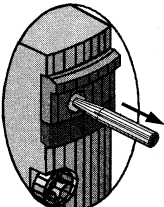
Actuate the manual override with automatic reset (pushing)		Reaction of valve
	Carefully press the plunger of the manual override as far as it will go.	The valve: – switches.
	Hold the plunger of the manual override pressed down.	– remains switched
	Release plunger. Spring resets the plunger to basic position.	– returns to basic position (not with 5/2-way double solenoid valve, Ident. code J)

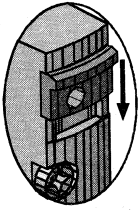
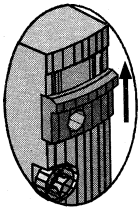

Before commissioning the CP valve terminal, return the manual override to basic position.

Actuate the manual override with locking	Reaction of valve
 <p data-bbox="743 510 940 577">Push the slide of the manual override down as far as possible.</p>	<p data-bbox="959 510 1054 555">The valve: – switches</p>
<p data-bbox="743 707 922 752">Leave slide in lower position.</p>	<p data-bbox="959 707 1134 730">– remains switched</p>
 <p data-bbox="743 835 946 902">Push the slide of the manual override up as far as possible.</p>	<p data-bbox="959 835 1198 925">– returns to basic position (not with 5/2-way double solenoid valve, Ident. code J)</p>

12.12.3 Locating faults

Impairment of function

When you switch on the compressed air supply or when you have tested the individual valves, you can learn the following about the operating status of the pneumatic system.

Operating status of the pneumatic system	Valve position	Error treatment when compressed air has been switched off
<p data-bbox="363 1435 523 1458">Air comes out...</p> <ul style="list-style-type: none"> <li data-bbox="363 1469 568 1514">– of common tubing connections <li data-bbox="363 1518 651 1547">– of work tubing connections <li data-bbox="363 1574 600 1603">– between the modules 	<ul style="list-style-type: none"> <li data-bbox="684 1462 842 1491">– basic position <li data-bbox="684 1518 855 1547">– switch position <li data-bbox="684 1574 842 1603">– basic position 	<ul style="list-style-type: none"> <li data-bbox="895 1462 1098 1518">• Check the seal or tubing fitting <li data-bbox="895 1574 1238 1653">• When switching on again regulate separate auxiliary pilot air 3 to 8 bar
<p data-bbox="363 1677 655 1722">Valve or pneumatic system</p> <ul style="list-style-type: none"> <li data-bbox="363 1704 655 1733">– does not react as expected <li data-bbox="363 1760 531 1789">– does not react <li data-bbox="363 1868 531 1897">– does not react 	<ul style="list-style-type: none"> <li data-bbox="684 1704 855 1733">– switch position <li data-bbox="684 1760 855 1789">– switch position <li data-bbox="684 1868 842 1897">– basic position 	<ul style="list-style-type: none"> <li data-bbox="895 1704 1050 1733">• Check tubing <li data-bbox="895 1760 1169 1839">• When switching on again, check operating pressure (e.g. pressure zones) <li data-bbox="895 1843 1114 1872">• Return for servicing <li data-bbox="895 1877 1190 1955">– Check regulator connection (apply pressure > 3 bar to regulator)

If the operating status of the pneumatic system differs from the desired pneumatic operating status, the following requirements are probably not fulfilled.

Desired pneumatic operating status	Requirement	Remarks
Free of leakage	– carefully laid tubing – regulated auxiliary pilot air	—
Fast reaction	Sufficient pressure supply via intermediate pressure modules	• Exhaust valve terminal at left and right-hand end plates (3/5 , 82/84)
Free of interference	Non-return valves in common exhaust tubing	– Applies when several systems with central ducted exhaust are used
Two pressure zones	Pressure zones are limited by isolating plate	– Can be fitted later
Vacuum operation/ low pressure operation	Separately regulated auxiliary pilot air (3-8 bar)	– Regulator can only be operated with pressure (between 3 and 8 bar)
EMERGENCY STOP of pressure zones	Regulator function for auxiliary pilot air guaranteed in spite of complete supply being switched off	– Regulator regulates auxiliary pilot air for all valve plates on a terminal
Slow switching on after EMERGENCY STOP	When there are control signals the auxiliary pilot air must be at full level immediately after it is switched on	

12.12.4 LED - display of valves

There is a yellow LED for each valve solenoid coil. This LED shows the switching status of the valve solenoid coil when the CP valve terminal is ready to operate..



Observe the assignment of the LED to the appropriate manual override: With IC connection:

- LED in front plug to upper manual override (14)
- LED in rear plug to lower manual override (12)

With MP-, ASI- or CP-connection:

- lower LED in plug cover to upper manual override (14)
- upper LED in plug cover to lower manual override (12)

12.12.5 Maintenance



Replace the flat seals between the valve block and the connecting plate if these seals are more than one year old. You thereby guarantee reliable sealing for your CP terminal.

The flat seals are seated at the bottom of the electrical connector plate (see diagram).

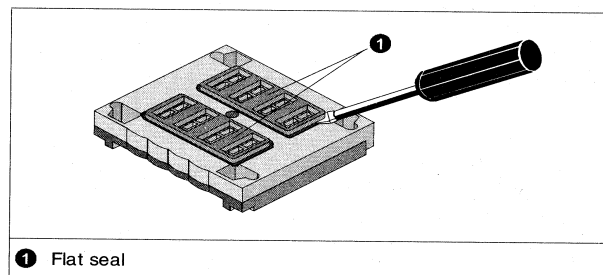

- Remove the self-adhesive flat seal from the recess. Use a screwdriver here to carefully loosen one corner of the seal. Then carefully pull the seal away from the electrical connector plate.
- Remove the protective foil from the new seal. Glue the flat seal into the recess.
- Place the end cover on the connecting lugs of the valve block. Carefully press down the end cover.
- Tighten the screws of the electrical connector plate in diagonally opposite sequence with 0.6 Nm (CPV10/14) or with 3 Nm (CPV18).
- CP terminals with CP connection and relay plates:
- Fit the plugs onto the relay outputs as described under "Connecting current-consuming devices to the relay plate."

12.13 Pneumatic filter regulateur LFR



12.13.1 Commissioning

Adjusting the regulator LR- , LFR-:

1. Slowly pressurize the complete system.
2. Pull the pressure setting button upwards (away from the housing).
3. Turn the pressure setting until the desired pressure is shown on the manometer. The input pressure must be at least 1 bar greater than the output pressure.
4. Press the pressure setting button downwards (towards the housing) to secure it against unintentional turning.

12.13.2 Maintenance and care

If a condensate level of approx 10 mm below the filter is reached:

- Open the bleeder screw by turning it in an anti-clockwise direction (see from below). The condensate can then flow out.

With less flow despite same pressure setting:

- Replace the filter element
- 1 Exhaust the system and the unit
 - 2 Unscrew the filter bowl in an anti-clockwise direction
 - 3 Grasp the new filter element only at the lower end
 - 4 Refit the parts in the reverse order from dismantling
 - 5 Recommission as described in the section "Commissioning"

12.13.3 Cleaning

- Use only the cleaning agents specified

Component	Cleaning agent
Filter bowl	Water or soap sud (max +60°C), benzine (aromatics free)

12.13.4 Eliminating faults

Fault	Possible cause	Remedy
No pressure display	Shut-off valve closed	Open shut-off valve
	Pressure not set	Set pressure with pressure setting button
	Manometer defective	Replace manometer
No pressure display pressure fails when compressed air is applied)	Filter element is dirty	Replace filter element
	Restriction between shut-off valve and maintenance unit	Check tubing
Pressure increases above set operating pressure	Defective valve face on sealing seat	Return to Festo
Exhaust can be heard at setting button	Valve seat damaged	Return to Festo
Exhaust can be heard at bleeder screw	Leakage in bleeder screw	Tighten or replace

Pos. No.	Qty.	Description	Dimensions	Part No.
	1	pneumatic filter regulator	Typ LFR - 1/4" - D - MINI	3P4340-17
	1	pneumatic filter regulator	Typ LFR - 1/2" - D - MIN	3P4340-18
	1	pneumatic filter regulator	Typ LFR - 1" - D - MAXI	3P4340-20

12.14 Greasing pump

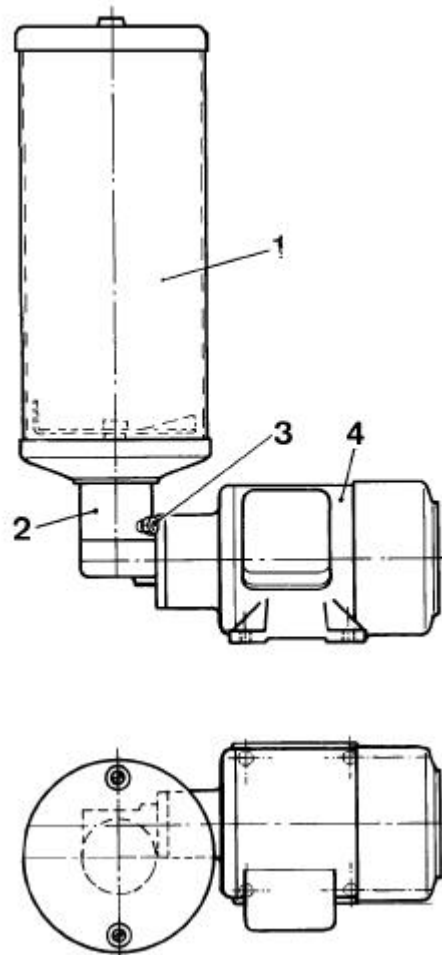

Pos. No.	Qty.	Description	Dimensions	Part No.
	1	greasing pump	GMM-G/4/2/040R5/A	3H0076-01
Recommended lubricant				
		Optimol Oben FD 1		9S2010-01
		Klüber Paraliq GA 351		9S2035-02
		Klüber Paraliq GB 363		9S2035-01
Any physiologically unobjectionable special lubricant				
	1	lubricant container	with a capacity of 3kg	-
	2	lubrication pump	GMM-G/4	-
	3	AC motor		-
	4	adjusting screw		-

13. List of the supplied documents from other companies

Designation	Type	Order no. of the documentation	Reg.
Gear motor	RF67 DT90 L4 BMG	3C2084-10	1
Vakuum pump	Lema 25	3H0011-01	2
Flowmeter	Promag 50 H	3Q2060-15	3
Rotatory pump	FKL 100	3HP000-28	4
Lifting and tipping device		HP000-30	5

14. Serviceadressen / Service addresses / Adresse du SAV

Stammwerk:

Stephanplatz 2
31789 Hameln
Telefon: 05151 / 583-0
Telefax: 05151 / 583-110
Email: Vertrieb@stephan-germany.com
Service@stephan-germany.com

www.Stephan-Germany.com



Verkaufsbüros Deutschland / Sales Branches Germany / Points de vente en Allemagne:

Nordwest

Stephanplatz 2
31760 Hameln
Telefon: 05151 / 583-182
Telefax: 05151 / 583-110
Email: GR@ASStephan-Germany.com

Südwest

Im Asemwald 48
70599 Stuttgart
Tel. 0711 / 728 57 54
Telefax 0711 / 728 96 21
Email: Stephan-Sued@gmx.de

Ausländische Tochtergesellschaft / Foreign Subsidiaries / Filiales à l'étranger:

Die Niederlande

The Netherlands
Les Pays-Bas
Stephan Nederland B.V.
Plesmanweg 15
Postbus 441
NL-7600 AK Almelo
Tel. 0031 / 546 / 87 41 11
Fax 0031 / 546 / 86 45 46
info@stephan.nl
www.stephan.nl

Schweiz

Switzerland
Suisse
A. Stephan und Söhne GmbH
& Co.
Verkaufsrepräsentation Schweiz

Gewerbehaus Tüfiwies
Schickmattweg 8
CH-8332 Russikon
Tel. 0041 / 1 / 955 06 08
Telefax 0041 / 1 / 955 06 88
Mobil 0041 / 079 / 355 90 92
a.stephan@bluewin.ch

Frankreich

France
Stephan France S.A.R.L.
ZAC du Madinet
Parc d'affaires SILIC
Rue de Campanules
F-77185 LOGNES
Tel. Bureaux 01-64 80 54
30,
Télécopieur S.A.V. et
Pièces détachées 01 64
80 50 78

Belgien

Belgium
Belgique
Stephan bvba
Sluis 11
B-9810 Eke/Nazareth
Tel. 0032 / 9 / 385 83 55
Telefax 0032 / 9 / 385 81 87

USA/Canada

Stephan Machinery Corp.
7200 Alum Creek Drive
Suite I
Columbus/OH 43217-1349
001 / 614 / 497-8951
001 / 614 / 497-9123
sales@stephan-usa.com
www.stephan-usa.com

Singapore

Stephan Machinery
Singapore Pte.Ltd.
23 Tagore Lane #03-12
Tagore 23 Warehouse
Singapore 787601
Tel. 0065 / 455 / 76 70
Telefax 0065 / 455 / 62 20
stephansingapor@pacific.net.sg

GUS

Dr. Alexej F. Dubinitsch
Verkaufsrepräsentant
STEPHAN c/o HAHN
Product Cons. Peters-
burg AG
Ul. Tschaikovskogo 83/7,
pom. 13
191123 Sankt Petersburg
Tel. 007 / 812 / 272 04 50
007 / 320 31 25
Telefax 007 / 320 31 24

Polska

Jan Danielewski
Verkaufsrepräsentant
STEPHAN
Ul. Zeromskiego 21
PL-60-544 Poznan
Tel. 0048 / 61 / 47 84 81
Telefax 0048 / 61 / 47 84 81

Vertretungen in über 40 Ländern. Anschriften auf Anfrage

Agencies in more than 40 countries, details on request.

Des agences dans plus de 40 pays. Adresses additionnelles sur demande

Index

A

ACK 44
Alphanumerical Keys 21
Automatic operation 24

C

Changing
 hydraulic fluid 54
 lubricant 53
 seals 49
Cleaning
 procedure 31
 solutions 57
Cover
 Positioning selector switch 34
CP Valve terminal 91
 Checking the valve functions 92
 LED - display of valves 96
 Location faults 95
 Maintenance 97
 Technical specifications 91

D

Dimensional drawing 12
Disinfection
 efficient time 58
 procedure 59
 protein errors 59
Double shell
 steam 36

E

Electronic equipment 42
Emptying 30

F

Fault repair
 drive motors 45
 electronic equipment 48
 hydraulics 47
 vacuum pumps 48
Function- and Softkeys 21

G

Gear motor 34
Greasing pump 100

H

Headroom 28
Hydraulic system
 maintenance 54
 starting-up 16
Hydraulic unit 39

I

Implements 12, 31, 35
 blade insert 35
 blade sharpening 49
 fitting 28
implements 14

L

LC-Display 17
Loading 28

M

Main motor 34
Maintenance 49
 frequency 32
 work 32
Manual operation 23
Motor performance 12

O

OP 17
 Alphanumerical Keys 21
 Automatic operation 24
 Function- and Softkeys 21
 Function keyboard 17
 input of nominal values 23
 LC-Display 17
 Manual operation 23
 program editing 26
 Softkeys 17
 start program 24
 System keyboard 17, 19
Ordering spares 60

P

Pneumatic filter regulator 98
Pneumatics 40
 maintenance unit 40
Pressure transducer, type 4 AP-
 30 72

Program editing 26

R

Rotational direction check 14

S

Safety valve type 718D 86
Saftey valve Series - 96 83, 85
 General Notes 83
 Installation and assembly 83
 Operation / Maintenance 84
 Testing / Marking 84
Service adresses 102
Shaft seal
 bowl mounting 51
 lid mounting 53
Shaft seal ring
 bowl disassembly 51
 lid disassembly 53
Softkeys 17
SPC 42
SPRO 43
Steam injection 37
Steam supply unit 41
Steam Trap - BP 23 71
 Maintenance 71
System keyboard 17, 19

T

Technical data
 electric 11
 energy consumption 10
 machine data 10
Test run 15
Testing Function 15
Touch keyboard 2005 44

V

Vacuum system 40

W

Wasserdampftafel 61
Water measuring device 42
Wellenabdichtung
 Nachschmierer 53