

Tetra Plex[®] C6, C8, C10

Plate heat exchangers



Application

Pasteurisation and general cooling/heating of dairy, beverage, viscous and other liquid food products.

Working Principle

Tetra Pak plate heat exchangers consist of a pack of corrugated metal plates. The corrugation patterns form channels for the passage of two fluids between which heat transfer takes place. The two fluids enter and leave the heat exchanger unit via the connections.

The plate pack is assembled between a fixed frame plate and a movable pressure plate, and is compressed by tightening bolts. The plates are fitted with gaskets that seal the channels.

The number of plates is determined by the flow rate, physical properties of the fluids, pressure drop and temperature program.

Design

Frame unit

The plate pack and pressure plate are suspended from an upper carrying bar and aligned by a lower guiding bar, both of which are fixed to the frame plate and support column.

The tightening bolts are equipped with ball bearing washers to facilitate opening and closing of the unit. The frame plate and support column have adjustable feet.

A single unit may comprise several heat exchanger sections, separated by connection plates with interchangeable connections. Tetra Plex heat exchangers have a modular design, which makes them easy to rebuild and adapt for new applications.

Plates

The plate corrugations promote fluid turbulence (for efficient heat transfer) as the two fluids flow past each other in alternate channels.

The chevron corrugation pattern supports the plates against differential pressure, providing maximum strength even at high working pressure. Different chevron designs are available, in order to obtain optimal heat transfer and low pressure drop. The unique distribution area assures an even flow over the plate surface. The hanging system enables easy handling of the plates in the frame and, together with the nesting corner profiles, results in a strong plate pack.

The plates are reversible and have parallel flow for maximum simplicity.

 **Tetra Pak**
protects what's good™

Tetra Plex[®] C6, C8, C10

Gaskets

The plates are supplied with glue-free Clip-On gaskets that are easy to replace, even when the plates are still hanging in the frame.

Standard Materials

Frame unit

Frame and pressure plate are either in solid stainless steel or in mild steel, clad with stainless steel with a glass-blasted finish. Connection plates are of stainless steel with a glass-blasted finish. All parts subject to product wetting are in acid-proof stainless steel. Outer surfaces in selected grades of stainless steel. Moveable nuts on tightening bolts are in chromium-plated brass.

Plates

Stainless steel grade 1.4401 (AISI 316).

Gaskets

EPDMFF or NBRFF. Clip-On design.

Optional Equipment

- Connections (51 mm) for pressure transmitter
- Thermometer pockets
- Plates in titanium or SMO
- Protection sheets
- Bolt protectors, stainless steel
- Extended legs
- Extra standard wrench
- Pneumatic tightening tool
- 3-A finish
- Test and material certificates
- Testing by authorised third-party inspectors

Technical Data

Connections

DIN, SMS, TRI-CLAMP, B.S./RJT and IDF/ISO male parts. Others on request.

Max. working pressure

Frame SR/KSR - 1.0 MPa (10 bar) overpressure
 Frame SM/KSM - 1.6 MPa (16 bar) overpressure
 Frame SH/KSH - 2.1 MPa (21 bar) overpressure
 Complies with PED 97/23/EC.

Capacity	C6	C8	C10
Pasteurisation*, l/h	15 000	35 000	65 000
Heating/cooling*, l/h	15 000	35 000	65 000

* low-viscous products

Dimensions

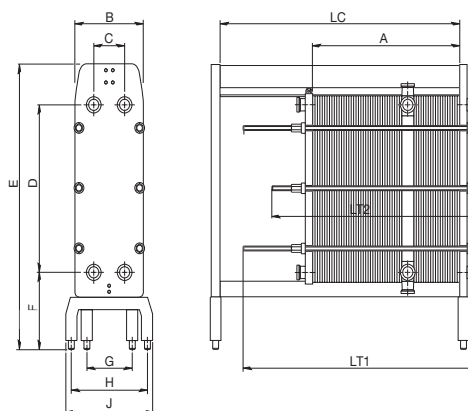

The overall length (LC) as well as A, LT1 and LT2 vary, depending on the number of plates and connection plates. The recommended free space along the sides of the unit and at the front end is 1.5 m.

Tetra Plex Measurements, mm	C6	C8	C10
B	370	492	670
C	129	220	324
D	859	1 095	1 324
E	1 420*	1 850*	2 160*
F	400*	500*	500*
G	240	320	320
H	460	590	750
J	520	670	830

*Adjustable feet ± 50 mm

N.B. Some models are not as shown in the pictures above.

Connections

Diameter, mm	C6	C8	C10
	51	76	76/101.6

Plates

Plate surface, m ²	C6	C8	C10
	0.18	0.38	0.62
Unpressed plate thickness, mm	0.5/0.6/0.7	0.5/0.6/0.7	0.5/0.6/0.7

Environment

Tetra Plex plate heat exchangers are designed for optimum utility consumption and heat recovery for each specific case. The exact energy consumption depends on the duty the specific heat exchanger performs.

Tetra Plex plate heat exchangers consist of parts that can be separated for recycling purposes.

