

Universal Machine UM/SK 150

- Mixing
- Cooling
- Dispersing
- Size Reduction
- Emulsifying
- Heating
- Deaerating (Vacuum)
- Cooking under vacuum / under pressure



Typical Applications:

- Processed Cheese
- All kinds of fresh cheese preparations
- Dressings, sauces
- Baby food
- Confectionery fillings
- Butter preparations
- Almond paste, marzipan
- Mayonnaise, ketchup

Advantages:

- Short batch times
- Configurable for many different applications
- Complete product emptying (minimal losses)
- Energy efficient
- Very few manual operating procedures
- Easy to integrate in a production line
- Production data can be easily transferred to external systems
- Traceability of historical production data
- PLC controlled process sequences

Options:

- Vacuum condensor for cooling and dehumidifying
- Charging device
- Discharge pump
- Discharge tank
- Frequency controlled main drive

Dimensions UM/SK 150:

overall height with lid open: 2300 mm

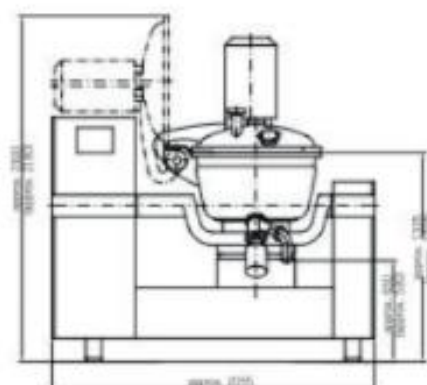
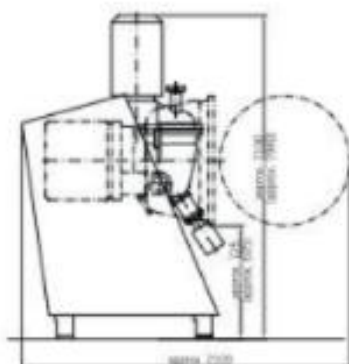

Machine Data:

Bowl content	(l) app.	150
Batch quantity (product-dependant)	(l) max.	120
Net weight of machine	kg	(according to design) 1,600
Max. vacuum in the bowl	bar (PSI)	-1 (-14.22)
Max. over pressure in the bowl	bar (PSI)	0.8 (11.6)
Max. operating temperature in the bowl	°C (°F)	110 (230)
Max. operating pressure in the double jacket	bar (PSI)	2.0 (28.44)
Max. operating temperature in the double jacket	°C (°F)	133 (271)
Min./max. compressed air	bar (PSI)	6-8 (85-114)

Guide values for the steam connection

Steam supply	kg/h	300
Steam feeding-pressure	bar (PSI)	6-8 (85-114)
Steam pressure at the machine	bar (PSI)	2-3.5 (28-50)
Steam supply connection	DN	32
Material specification	1.4301 (AISI 304) or similar	
Shaft sealings	standard: sealing ring optional: mechanical seal	
discharge height - tilting	mm	725 (605) acc. to type of motor
discharge height - valve	mm	650 (530) acc. to type of motor

Energy requirement

Main motor n=1500/3000 min ⁻¹	kW	29/33
Mixing baffle drive n = 24 min ⁻¹	kW	1.5
Vacuum pump	kW	0.75
Installed energy	kW app.	39
Steam - injection	kg/h	240
Steam - double jacket	kg/h	depends on product/batch/process
Water - vacuum pump	l/h app.	120
Water requirement for recipe	l/min app.	60
Connection for compressed air	inch	3/8"
Connection for water (recipe)	DN	32
Voltage	V/Hz	400/50