

# IQE200 Series

## Intelligent Quantum Efficiency Systems



User's Manual

**DRIEL**  
**INSTRUMENTS**  
A Newport Corporation Brand



## TABLE OF CONTENTS

1	GENERAL INFORMATION .....	6
1.1	SYMBOLS AND DEFINITIONS .....	6
1.2	GENERAL WARNINGS .....	7
1.3	ELECTRICAL HAZARDS .....	7
1.4	FIRE HAZARDS .....	8
1.5	LAMP HANDLING .....	8
1.6	DISPOSAL OF COMPUTER BATTERIES.....	8
2	THEORY OF OPERATION .....	9
2.1	DATA CALCULATIONS .....	10
4	BASIC SYSTEM SETUP .....	15
4.1	ITEMS INCLUDED WITH SYSTEM.....	15
4.2	UNPACKING .....	16
4.3	CHOOSING A LOCATION .....	16
4.4	ELECTRICAL CONNECTIONS .....	16
4.5	LAMP INSTALLATION .....	17
4.6	XENON LAMP INSTALLATION .....	19
4.7	QUARTZ TUNGSTEN HALOGEN (QTH) LAMP INSTALLATION .....	21
4.8	COMPUTER CONNECTIONS .....	22
4.9	LAMP IGNITION.....	23
5	SAMPLE POSITIONING .....	24
6	STANDARDS .....	27
6.1	DETECTOR STANDARDS .....	27
6.2	SPECULAR REFLECTANCE STANDARDS .....	28
6.3	DIFFUSE REFLECTANCE STANDARDS .....	28
7	QUICK-START GUIDE.....	29
7.1	SCANNING A SAMPLE .....	29
7.2	LOADING A PREVIOUSLY SAVED SCAN .....	33
8	SYSTEM VERIFICATION .....	35
8.1	VERIFICATION PROCESS.....	35
8.2	LAMP OPTIMIZATION .....	37
9	ADVANCED SYSTEM CONFIGURATION .....	42
9.1	CHOPPER CONTROLLER SETTINGS (ACDC Systems Only).....	42
9.2	INTEGRATING SPHERE OPTION .....	43
9.3	LIGHT BIASING OPTION .....	44
9.4	GAIN ADJUSTMENTS .....	45
9.5	VOLTAGE BIASING.....	45
9.6	LIGHT SPOT SIZE ADJUSTMENT.....	46
9.7	MONOCHROMATOR RESOLUTION .....	47
10	SOFTWARE .....	48
10.1	HOME SCREEN OVERVIEW .....	48
10.2	DISPLAYING GRAPHS.....	51
10.3	GRAPH CONTROLS.....	55
10.4	METHODS .....	57
10.5	INSTRUMENT UTILITIES .....	59
10.6	Jsc CALCULATIONS .....	62
11	CALIBRATION.....	64
11.1	DETERMINE IF RECALIBRATION IS NECESSARY .....	64
11.2	CALIBRATION DATA.....	64

11.3	HISTORICAL CALIBRATION FILES.....	65
11.4	EXTERNAL QUANTUM EFFICIENCY (EQE) CALIBRATION .....	66
11.5	SPECULAR REFLECTANCE (RS) CALIBRATION.....	70
11.6	DIFFUSE REFLECTANCE (RD) CALIBRATION.....	76
12	MAINTENANCE .....	80
12.1	LAMP REPLACEMENT.....	80
12.2	CLEANING .....	80
12.3	ARC LAMP HOUSING INSPECTION.....	81
12.4	QTH LAMP HOUSING INSPECTION.....	83
13	TROUBLESHOOTING .....	84
13.1	SYSTEM VERIFICATION ERROR .....	84
13.2	TEST SAMPLE SATURATION .....	85
13.3	POWER SUPPLY ERROR MESSAGES .....	85
13.4	DIFFICULTY IGNITING ARC LAMP .....	86
13.5	LAMP CARE AND HANDLING .....	86
13.6	LAMP HOUSING THERMOSTAT.....	86
13.7	GENERAL TROUBLESHOOTING.....	88
14	SPECIFICATIONS.....	89
14.1	PHYSICAL SPECIFICATIONS, ACDC SYSTEM .....	89
14.2	PHYSICAL SPECIFICATIONS, AC SYSTEM.....	89
14.3	ELECTRICAL SPECIFICATIONS .....	89
15	EU DECLARATION OF CONFORMITY.....	90
16	APPENDIX I – CABLES AND ADAPTERS.....	91
17	APPENDIX II – LOCK-IN AMPLIFIER BACKGROUND.....	93
18	APPENDIX III – SYSTEM PARAMETER DETAILS.....	95
19	WARRANTY AND SERVICE .....	98
19.1	CONTACTING ORIEL INSTRUMENTS.....	98
19.2	REQUEST FOR ASSISTANCE / SERVICE.....	99
19.3	REPAIR SERVICE .....	99
19.4	NON-WARRANTY REPAIR .....	99
19.5	WARRANTY REPAIR .....	100
19.6	LOANER / DEMO MATERIAL.....	101

## LIST OF FIGURES

Figure 1: AC System Block Diagram .....	11
Figure 2: ACDC System Block Diagram .....	12
Figure 3: Interior of Standard IQE System.....	13
Figure 4: Sample Compartment.....	14
Figure 5: Access Panel .....	17
Figure 6: Lamp Housing.....	18
Figure 7: Arc Lamp Orientation .....	19
Figure 8: Arc Lamp.....	20
Figure 9: Arc Lamp Installed .....	20
Figure 10: QTH Lamp Installation .....	21
Figure 11: Power Supply Front Panel .....	23
Figure 12: Sample Positioning .....	25
Figure 13: Sample Probing .....	25
Figure 14: Basic Test Sample Platform .....	26
Figure 15: Light Bias Fiber Holder .....	26
Figure 16: Sample Detectors .....	27
Figure 17: Specular Reflectance Standards .....	28
Figure 18: Diffuse Reflectance Standards .....	28
Figure 19: Starting a Scan .....	29
Figure 20: Selecting Scan Method.....	30
Figure 21: Scan In Progress .....	31
Figure 22: Log File Header .....	31
Figure 23: Scan Process Flowchart.....	32
Figure 24: Load File From Home Screen.....	33
Figure 25: Selecting Files To Be Loaded.....	33
Figure 26: Tabular Display of Loaded Log File.....	34
Figure 27: Final Data Log Files.....	35
Figure 28: Final Data Files for ACDC Standard Range System.....	36
Figure 29: Calibrated Detector Files for Extended Range System with Integrating Sphere.....	36
Figure 30: Reference Detector Voltage Comparison Graph.....	37
Figure 31: Reference Detector Voltage Table .....	38
Figure 32: Select Wavelength .....	39
Figure 33: Select Utilities .....	39
Figure 34: Selecting the Multiplexer Utility.....	40
Figure 35: Multiplexer Utility Screen .....	40
Figure 36: Chopper Running.....	42
Figure 37: Chopper Stopped.....	42
Figure 38: Optional Integrating Sphere with Light Bias Fiber Holder .....	43
Figure 39: Optional Light Bias System.....	44
Figure 40: Light Bias Amplifier .....	45
Figure 41: Micrometer Driven Slit .....	47
Figure 42: Micrometer Reading In Closed Position .....	47
Figure 43: Home Screen .....	48
Figure 44: Status Window .....	50
Figure 45: Saved Scan, Default View .....	51
Figure 46: Edit Graph Properties .....	52
Figure 47: Remove Graph.....	53
Figure 48: Saved Scan, Tabular View .....	53
Figure 49: Data Viewed in Notepad.....	54
Figure 50: Graph Controls.....	55
Figure 51: Zoom Control Group .....	55

Figure 52: Zoom to Rectangle .....	55
Figure 53: X-Zoom .....	56
Figure 54: Y-Zoom .....	56
Figure 55: Zoom In about Point .....	56
Figure 56: Zoom Out about Point.....	56
Figure 57: Zoom to Fit.....	56
Figure 58: Methods Screen.....	57
Figure 59: Gain Settings .....	58
Figure 60: Monochromator Utility .....	59
Figure 61: Merlin™ Utility.....	60
Figure 62: Multiplexer Utility.....	61
Figure 63: Select Jsc.....	62
Figure 64: Jsc Calculation Results.....	63
Figure 65: Files for Calibration Standards .....	64
Figure 66: Historical Calibration Data .....	65
Figure 67: Selecting the EQE Calibration Routine.....	66
Figure 68: EQE Calibration, Step 2.....	67
Figure 69: EQE Calibration Process Flowchart .....	69
Figure 70: Selecting the Specular Reflectance Calibration Routine .....	70
Figure 71: RS Calibration, Step 2 .....	72
Figure 72: Low Specular Reflectance Standard During Calibration .....	72
Figure 73: High Specular Reflectance Standard During Calibration .....	74
Figure 74: RS Calibration Process Flowchart.....	75
Figure 75: Selecting the Diffuse Reflectance Calibration Routine .....	76
Figure 76: RS Calibration, Step 2 .....	77
Figure 77: RD Calibration Process Flowchart.....	79
Figure 78: Arc Lamp Housing Construction .....	81
Figure 79: Arc Lamp Installed Backwards .....	87
Figure 80: Connection Adapter Options.....	91
Figure 81: Cable Options .....	92
Figure 82: Detailed Scan Flowchart.....	97





## 1 GENERAL INFORMATION

Thank you for your purchase of this IQE system from Oriel Instruments.

Please carefully read the following important safety precautions prior to unpacking and operating this equipment. In addition, please refer to the complete User's Manual for additional important notes and cautionary statements regarding the use and operation of the system.

Do not attempt to operate the system without reading all the information provided with each of the components.

### 1.1 SYMBOLS AND DEFINITIONS

	<b>WARNING</b> Situation has the potential to cause bodily harm or death.
	<b>CAUTION</b> Situation has the potential to cause damage to property or equipment.
	<b>ELECTRICAL SHOCK</b> Hazard arising from dangerous voltage. Any mishandling could result in irreparable damage to the equipment, and personal injury or death.
	<b>EUROPEAN UNION CE MARK</b> The presence of the CE Mark on Newport Corporation equipment means that it has been designed, tested and certified as complying with all applicable European Union (CE) regulations and recommendations.
	This international symbol implies an alternating voltage or current.
Note:	Additional important information the user or operator should consider.

**Please read all instructions that were provided prior to operation of the system. If there are any questions, please contact Oriel Instruments or the representative through whom the system was purchased.**

## 1.2 GENERAL WARNINGS

- Read all warnings and operating instructions for this system prior to setup and use.
- Do not use this equipment in or near water.
- To prevent damage to the equipment, read the instructions in the equipment manual for proper input voltage.
- This equipment is grounded through the grounding conductor of the power cords.
- Route power cords and other cables so they are not likely to be damaged.
- Disconnect power before cleaning the equipment
- Do not use liquid or aerosol cleaners; use only a damp lint-free cloth.
- Lock out all electrical power sources before servicing the equipment.
- To avoid explosion, do not operate this equipment in an explosive atmosphere.
- Qualified service personnel should perform safety checks after any service.
- If this equipment is used in a manner not specified in this manual, the protection provided by this equipment may be impaired.
- To prevent damage to equipment when replacing fuses, locate and correct the problem that caused the fuse to blow before re-applying power.
- Do not block ventilation openings.
- Do not position this product in such a manner that would make it difficult to disconnect the power cords.
- Use only the specified replacement parts.
- Follow precautions for static sensitive devices when handling this equipment.
- This product should only be powered as described in the manual.
- Do not remove the cover for normal usage

## 1.3 ELECTRICAL HAZARDS

Make all connections to or from the power supply with the power off.

Do not use the power supply without its cover in place. Lethal voltages are present inside.

## 1.4 FIRE HAZARDS

Lamps are extremely hot during operation, and for several minutes after being shut off. Keep flammable objects away from the lamp and lamp housing.

Newport Research (fan-cooled) Housings are equipped with a condenser lens. The re-focused output of this lens can cause ignition of flammable targets (ex: wooden walls, certain chemicals).

To avoid fire hazard, use only the specified fuses with the correct type number, voltage and current ratings as referenced in the appropriate locations in the service instructions or on the equipment. Only qualified service personnel should replace fuses.

## 1.5 LAMP HANDLING

Read all information and warnings provided with lamp.

The arc lamp used in Xenon-based IQE systems is filled with rare gas at high pressure, so there is a danger of lamp explosion due to mechanical failure. This is particularly true when the lamp is operating since the internal pressure can reach tens of atmospheres. Thermal strains can cause the lamp to explode under certain conditions.

Never touch any lamp with bare fingers or other contaminants. Skin oil or other substances can burn into the lamp envelope during operation and negatively affect the lamp's performance and lifetime.

Always wear appropriate gloves and impact-resistant goggles when handling any lamp. Avoid any mechanical strain during handling. Do not operate the lamp without all housing panels in place.

Lamps become very hot after only a few minutes of operation (up to 150°C) and remain quite hot for at least 10 to 15 minutes after being turned off.

## 1.6 DISPOSAL OF COMPUTER BATTERIES

Your IQE system's laptop computer uses a lithium ion or nickel metal hydride battery and a reserve battery.

In the USA, computer batteries fall under the e-waste category for hazardous waste management. This is overseen by each state's version of the Environmental Protection Agency. Before disposing of any battery, please refer to your state's regulations for proper e-waste disposal.

For customers outside of the USA, please refer to your country's regulations governing the management and disposal of e-waste.

## 2 THEORY OF OPERATION

---

Oriel Instrument's patent-pending IQE200 system allows users to measure External Quantum efficiency (EQE) also known as Incident Photon to Charge Carrier Efficiency (IPCE) as well as Internal Quantum Efficiency (IQE) for devices with energy bandgap in the UV to SWIR region. This includes solar cells, detectors, etc.

The system utilizes industry standard Oriel components for the tunable light source. The IQE200 system provides a "turnkey" solution by providing the light source, monochromator, detectors, related electronics, software and PC in a preconfigured, assembled and calibrated format.

Accessory modules are available to provide sample positioning, temperature control, electrical probing capabilities, light bias and diffuse reflectance measurement. The IQE200 incorporates a novel geometry which splits the beam, allowing for measurement of EQE and the reflective losses to quantify IQE without the need to move the sample or reconfigure the hardware.

The system uses a Xenon or Quartz Tungsten Halogen (QTH) lamp as its monochromator light source. The monochromatic modulated beam is obtained using the system consisting of an Oriel 1/8<sup>th</sup> meter monochromator, a chopper, lock-in amplifier and order-sorting filters and other optics. For DC measurements, a Newport power meter is utilized.

The beamsplitter delivers the light simultaneously to the sample and to the reference detector. The computer controls the monochromator, the lock-in amplifier as well as the multiplexer used for data acquisition from the three detectors. The IQE software performs the needed computations and calibrations. The software is pre-loaded onto the laptop computer provided with the system.

The unique design of the system meets the requirements outlined in ASTM Method E 1021-06. The electronic band structure in a photovoltaic device introduces a wavelength dependent optical absorptivity. A photon with energy larger than the band gap is typically absorbed by the material, while the material is transparent for a photon with energy smaller than the band gap. The absorbed photon energy creates an electron-hole pair, which leads to creation of photocurrent. The spectral response for a photovoltaic device is dependent on this induced photocurrent and on the wavelength of incident light.

According to ASTM 1021-08, the power spectral responsivity,  $R_{pa}(\lambda)$ , for collected electrons per incident photons may be converted to external quantum efficiency,  $EQE(\lambda)$  and then to internal quantum efficiency,  $IQE(\lambda)$ , using the equations below:

$$EQE(\lambda) = \frac{hc}{q} \frac{R_{pa}(\lambda)}{\lambda}$$

and

$$IQE(\lambda) = \frac{EQE(\lambda)}{1 - R_{sample}(\lambda)}$$

where  $R_{sample}(\lambda)$  is effective sample reflectance,  $\lambda$  is the wavelength in nanometers,  $h$  is Planck's constant,  $c$  the speed of light, and  $q$  the electron charge.

## 2.1 DATA CALCULATIONS

EQE = External Quantum Efficiency

IQE = Internal Quantum Efficiency

$\lambda$  = wavelength

SR = Spectral Responsivity (A/W)

$R_s$  = Reflectance, Specular

$R_d$  = Reflectance, Diffuse

$m, n$  =  $R_s$  proprietary calibration factors

$t, u$  =  $R_d$  proprietary calibration factors

$Cal_{ch1}$  = SR proprietary calibration factor

### External Quantum Efficiency

$$EQE = (1240 * Gain_{ch1} * Cal_{ch1} * V_{ch2}) / (Gain_{ch2 AC} * Gain_{ch2 DC} * \lambda * V_{ch1})$$

### Spectral Responsivity

$$SR = EQE * \lambda / 1240$$

### Reflectance

$$R_s = m * (V_{ch3} / V_{ch1}) + n$$

$$R_d = t * (V_{ch4} / V_{ch1}) + u \quad [\text{integrating sphere option required for } R_d]$$

### Internal Quantum Efficiency

$$IQE = EQE / (1 - R_s - R_d)$$

If the integrating sphere option is not enabled,  $R_d = 0$ .

### Short-Circuit Current Density

$$J_{sc} = \int \text{Solar Spectrum} * EQE * d(\lambda)$$

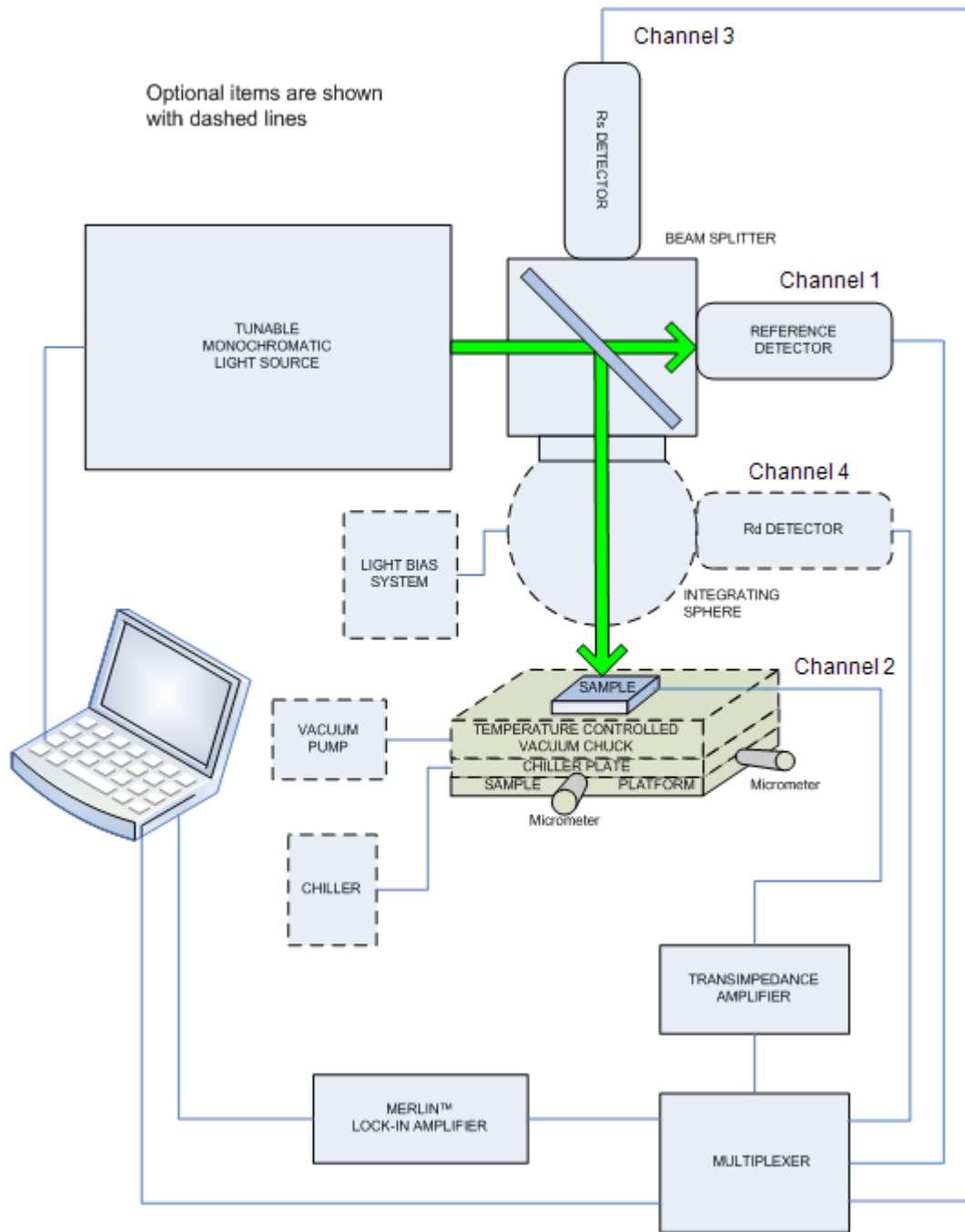

Figure 1: AC System Block Diagram

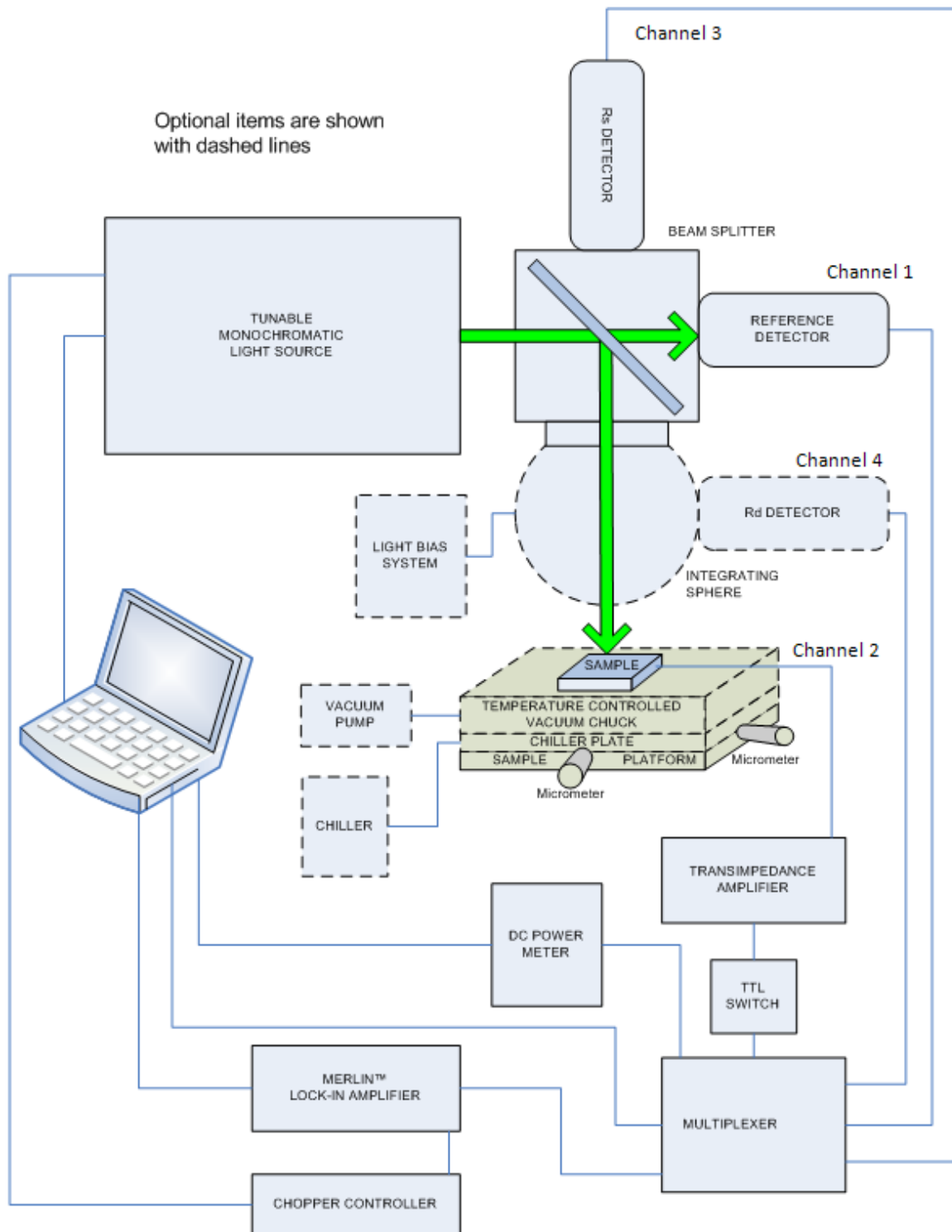

Figure 2: ACDC System Block Diagram

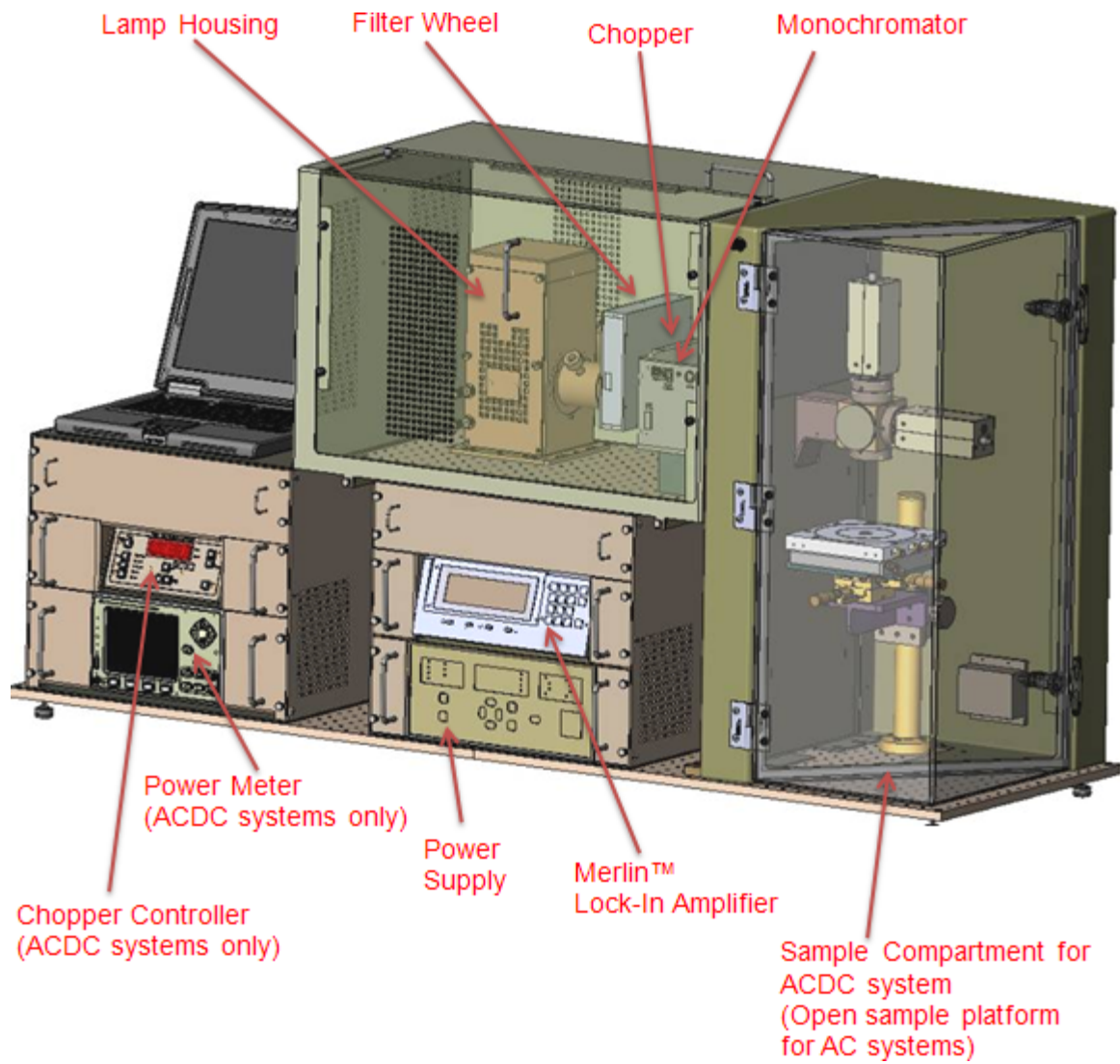

Figure 3: Interior of Standard IQE System

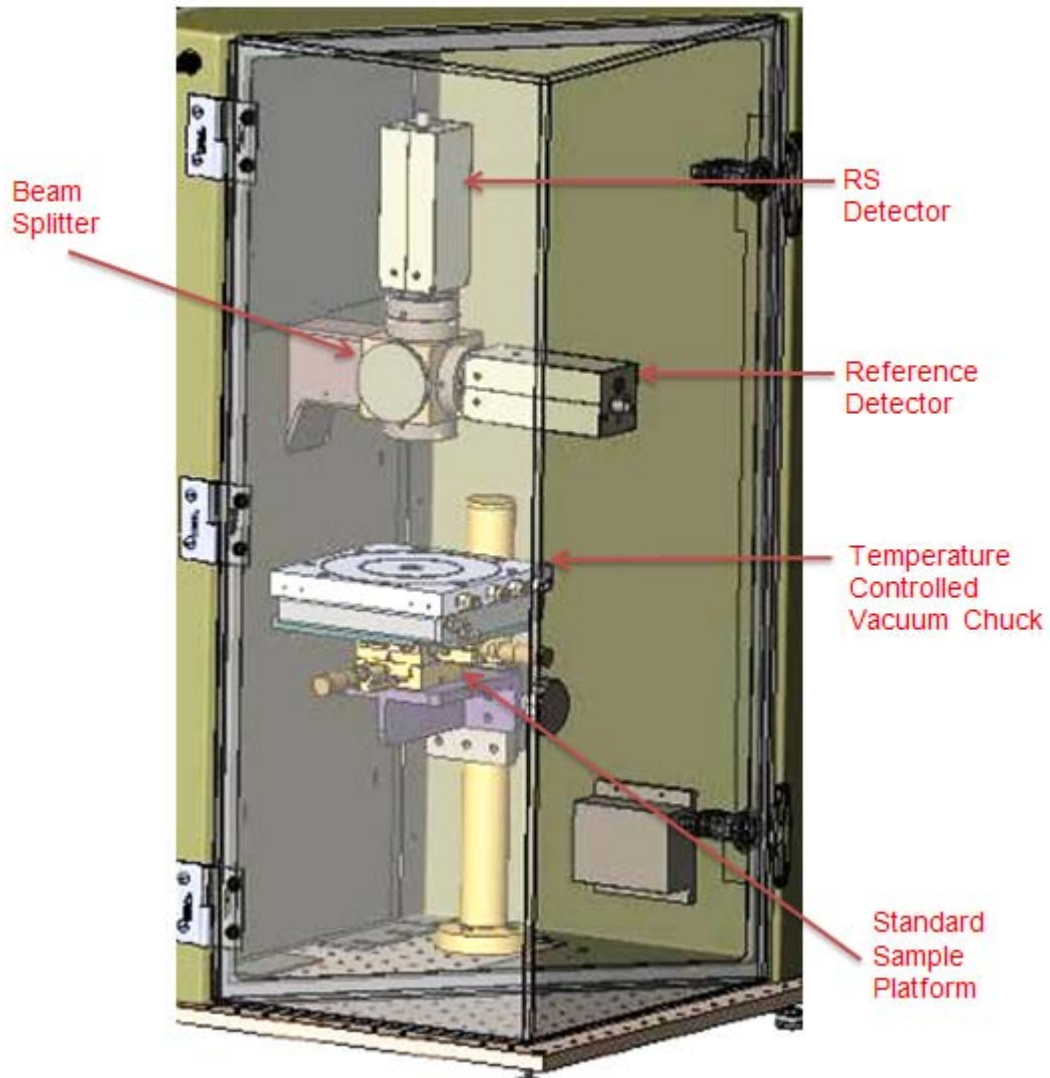

Figure 4: Sample Compartment

## 4 BASIC SYSTEM SETUP

---

### 4.1 ITEMS INCLUDED WITH SYSTEM

The following items are included with all IQE systems:

- IQE AC or ACDC system
- Laptop computer with IQE software installed
- USB hub (ACDC systems only, packaged with computer)
- International line cord adapter for computer (220VAC systems only, packaged with computer)
- Xenon lamp (quantity 1) or QTH lamp (quantity 2)
- Detector Standard, Si
- Detector Standard, Ge (for extended range systems)
- Low specular reflectance standard with non-reflective pad
- High specular reflectance standard
- Cable, BNC Male to BNC Male
- Cable, BNC Male to Micrograbber Clips
- Cable, BNC Male to Mini Alligator Clips
- Adapter, BNC Jack to Jack (ACDC systems only)
- System Datasheet
- Packing List
- User's manuals: IQE system and light bias amplifier

Optional items are listed below. Add-ons are shipped pre-installed on the IQE system.

- Integrating sphere add-on
- Low and high diffuse reflectance standards (integrating sphere systems only)
- Light biasing system
- Temperature controlled vacuum chuck add-on
- Probe kit(s) \*
- Vacuum pump \*
- Chiller \*
- XY travel mapping add-on

For additional items which are ordered separately (such as light bias filters), please refer to the Order Acknowledgement which was emailed when the sales order was placed. These items may be shipped separately.

**\* Typically utilized with the temperature controlled vacuum chuck.**

## 4.2 UNPACKING

Remove all items from the shipping containers and verify that the primary items as well as any optional accessories that were ordered are accounted for by cross-checking the contents against the packing slip and the delivery note.

Be sure to retain all packing materials in the event that the system needs to be transported to another location or placed into storage. Note that if the shipping crate is disposed, a replacement shipping crate may be purchased from Oriel Instruments if necessary.

If any items are missing or damaged, immediately contact Oriel Instruments or the Newport representative from whom the system was purchased.

## 4.3 CHOOSING A LOCATION

Choose an installation location where the power requirements can be met for the IQE system and all accessories. Be sure power is not applied to the system until the setup has been completed.

The environment should be that of a typical laboratory atmosphere, without excessive humidity and contaminants in the air. Refer to the temperature controlled vacuum chuck manual for special considerations regarding the location of this optional accessory's pump and tubing.

Do not allow the ventilation holes on the IQE system or its computer to be blocked. Air should be able to circulate freely around the system.

When the system is placed in its final location, check to ensure that no items have become loose during handling.

## 4.4 ELECTRICAL CONNECTIONS

Each IQE system is configured for the appropriate mains voltage for the end user's country. Note that in nations where the voltage mains varies by region, the operating voltage should have been specified at the time that the order was placed.

The quantity of electrical cords varies according to the specific model and which accessories were ordered. The optional chiller, vacuum pump, light bias system and XY mapping add-on each require an extra power cord. When the integrating sphere option is used on extended range IQE systems, this will also require an extra power cord.

Model	Power Cord Qty
IQE-AC-QTH-SI	5
IQE-AC-XE-SI	5
IQE-AC-QTH-EXT1	7
IQE-AC-XE-EXT1	7
IQE-ACDC-XE-SI	8
IQE-ACDC-QTH-SI	8
IQE-ACDC-XE-EXT	10
IQE-ACDC-QTH-EXT	10

## 4.5 LAMP INSTALLATION



### **CAUTION!**

When installing the lamp, you **MUST**:

- Wear eye protection.
- Wear powder-free gloves.
- Make sure the power supply is turned off.

Read all warning labels and literature that came with the lamp. Remove the panel shown from the front of the system in order to access the lamp housing. The power supply must be unpowered before installing the lamp. Never touch the envelope of any lamp. If it is touched, clean it with isopropyl alcohol and a lint-free tissue such as a Kimwipe.

In order to prevent getting contaminants on the glass envelope, Oriel Instruments advises using powder free gloves while handling the lamp. Wearing goggles is also strongly advised. Use care when handling the lamp. Do not bend, flex, or otherwise exert any unnecessary force on the lamp. The lamp is under pressure and glass particles can act as projectiles if the lamp is broken.

Unpack the lamp carefully. Set aside the packing material and box, so that they can be used for lamp storage if the IQE system is to be relocated at a later date (never move an IQE system with the lamp installed).



**Figure 5: Access Panel**

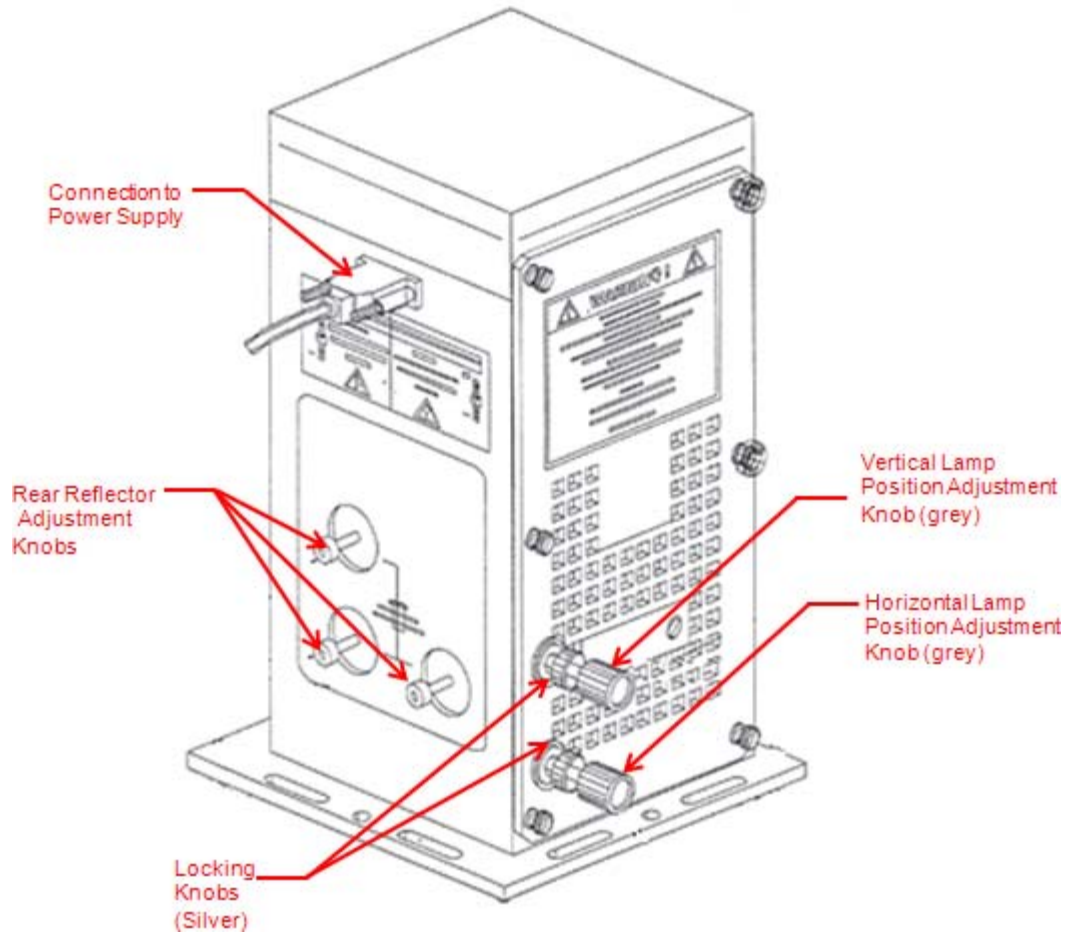

**Figure 6: Lamp Housing**

To open the research housing, unscrew the six knurled black thumb screws on the side of the housing to remove the access door as shown in above. It may be necessary to back off the knurled lock nuts on the lamp positioning adjustment screws. **Do not turn the grey end caps** as this will move the lamp position. The lamp position and reflector position have been pre-set at the factory.

If the rear reflector or lamp position adjustment knobs are moved, it is possible that the system will require recalibration. However, before performing a recalibration, ensure that one is necessary by running a scan of the test sample provided with the system. If it has not changed, then do not perform a calibration. System calibration should be performed only when absolutely necessary.

## 4.6 XENON LAMP INSTALLATION

Remove the twist tie or cable tie holding the sensor block in place. Loosen the thumbscrew on the lamp mount.

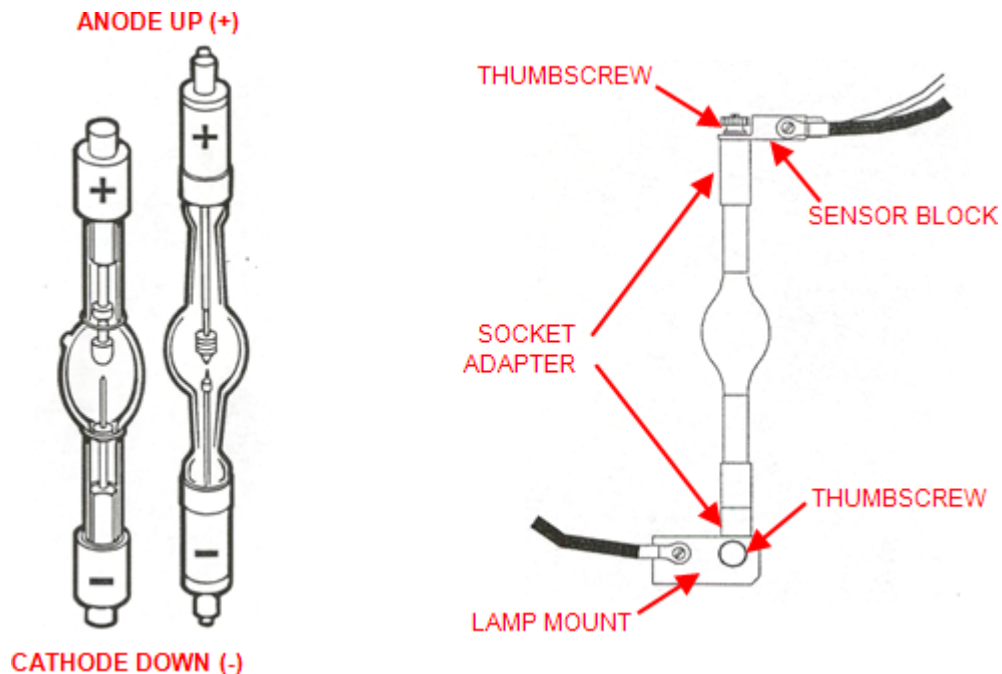

**Figure 7: Arc Lamp Orientation**

Remove the knurled thumbscrews that come installed on the anode end of the lamp. Place the sensor block onto the threaded post at the anode (+) of the lamp. Secure loosely with the knurled thumbscrew that comes with the lamp.

Carefully place the lamp into the lamp mount with the cathode side down. This is the end of the lamp where a brass socket adapter has already been installed by the factory. Rotate the lamp so that the protrusion on the envelope and the starter wire (if provided with the lamp) are facing towards the back of the lamp housing. The back of the lamp housing is where the baffle covers the fan, directly opposite of the door opening. After the lamp has been oriented correctly, be sure to tighten the thumbscrew on the lamp mount and tighten the thumbscrew at the top of the Lamp.

Replace the door of the lamp housing, making sure to engage the safety interlock tabs. Replace the nuts holding the door in place. Under no circumstances should the interlock tabs be removed or the interlock circumvented or defeated. Note that the lamp housing cannot be operated without its door being secured in place. If the door is not secured in place, an iLOC error will appear on the power supply display.

Replace the access cover on the IQE system and apply power to the IQE system.

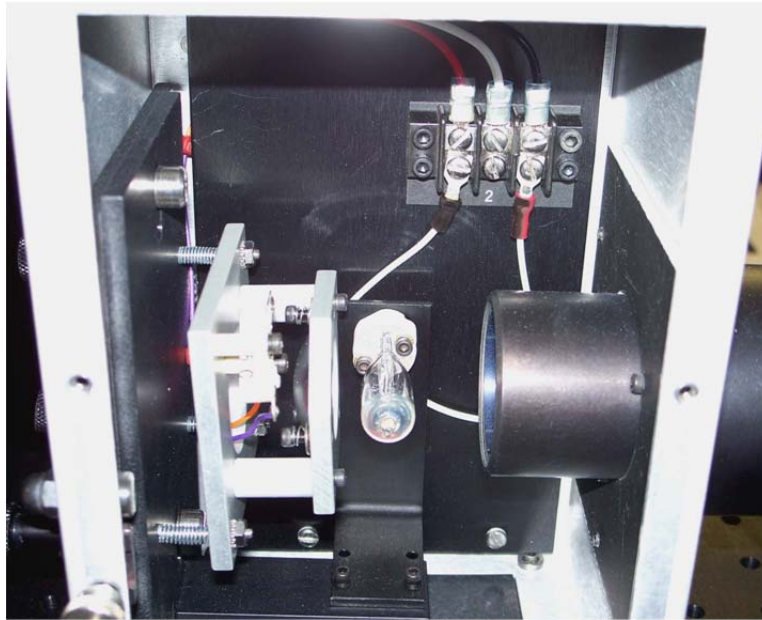

**Figure 8: Arc Lamp**



**Figure 9: Arc Lamp Installed**

## 4.7 QUARTZ TUNGSTEN HALOGEN (QTH) LAMP INSTALLATION



**Figure 10: QTH Lamp Installation**

A QTH lamp is very delicate, so it should not be subjected to excessive strain or it may break.

Mount the lamp in the socket adapter by carefully lining up the two pins of the lamp with the socket and pushing in slowly without excessive rocking back and forth.

Replace the door of the lamp housing, making sure to engage the safety interlock tabs. Replace the nuts holding the door in place. Under no circumstances should the interlock tabs be removed or the interlock circumvented or defeated. Note that the lamp housing cannot be operated without its door being secured in place. If the door is not secured in place, an iLOC error will appear on the power supply display.

Replace the access cover on the IQE system and apply power to the IQE system.

## 4.8 COMPUTER CONNECTIONS

The IQE system utilizes a computer with settings specifically configured for this application. This computer includes all the drivers and software necessary to perform quantum efficiency, reflectance and spectral responsivity measurements.

Please remove any USB devices, such as a mouse, from the computer prior to making the IQE system connections to the computer. Use of other USB devices is not recommended during initial setup as they may interfere with correct assignment of the USB port. Some USB devices allocate resources that the system may need for proper operation.

One may attempt to install devices like memory sticks or external hard drives after the system is fully set up and validated. However, Newport cannot guarantee functionality of the IQE system or the installed product.

Verify that all instruments are plugged in and turned on. Connect the cables from the various instruments to the USB ports as they are labeled on the computer. ACDC systems include a USB hub.

If a device is not being detected by the software, verify in the Windows device manager that all instruments are being recognized. Refer to the troubleshooting section of this manual for more information.

Please do not attempt to upgrade the operating system. Use of an alternative computer or installation of any other software may alter the functionality of the IQE200 software. It is particularly important to not install any other National Instruments drivers onto this computer, to avoid conflicts.

If upgrades are made to the National Instruments drivers or Windows operating system, Newport cannot guarantee proper performance. Problems resulting from any software or driver installation or modification are not covered under warranty. If factory servicing is required to correct problems caused by unauthorized installations or modifications, normal repair service fees will apply.

## 4.9 LAMP IGNITION

The power supply has been factory configured for proper operation with the IQE system. No adjustments to the settings are required.

To start the lamp, first switch on the power supply using the switch located on its front panel. There is no output until the Lamp Start button on the front panel of the power supply. A Xenon lamp will go to full power immediately after it has been ignited. A QTH lamp will gradually ramp up to the operating current to minimize the stress on the lamp. **All types of lamps must be allowed to fully warm up and stabilize prior to data acquisition.**

By pressing the Display/Select button, one can observe the current, voltage, watts or lamp hours on the display. A red LED in the display area indicates which parameter is being shown. The average lifetime is 1000 hours for a Xenon lamp and 50 hours for a QTH lamp. Periodically check the lamp hours so that a replacement lamp may be ordered before the original lamp fails.

The lamp housing is cooled by its own fan. The fan speed is regulated by the electronics built into the lamp housing. An additional safety shutoff switch is also present to turn off the lamp in case of overheating.

When one is finished with using the system, use the Lamp Off button to turn off the lamp. While the power switch is left on, the lamp housing fan will switch to high speed to cool the lamp. This cooling process takes approximately 20 minutes. After this time has elapsed, the fan shuts off.

Note: Excessive ignition places stress on the lamp, wears away the arc lamp electrodes and will reduce lamp life. Always allow the lamp to cool off completely before re-igniting it. If there are any difficulties igniting the lamp, refer to the troubleshooting section of this manual for possible causes of lamp ignition failure and power supply error messages.

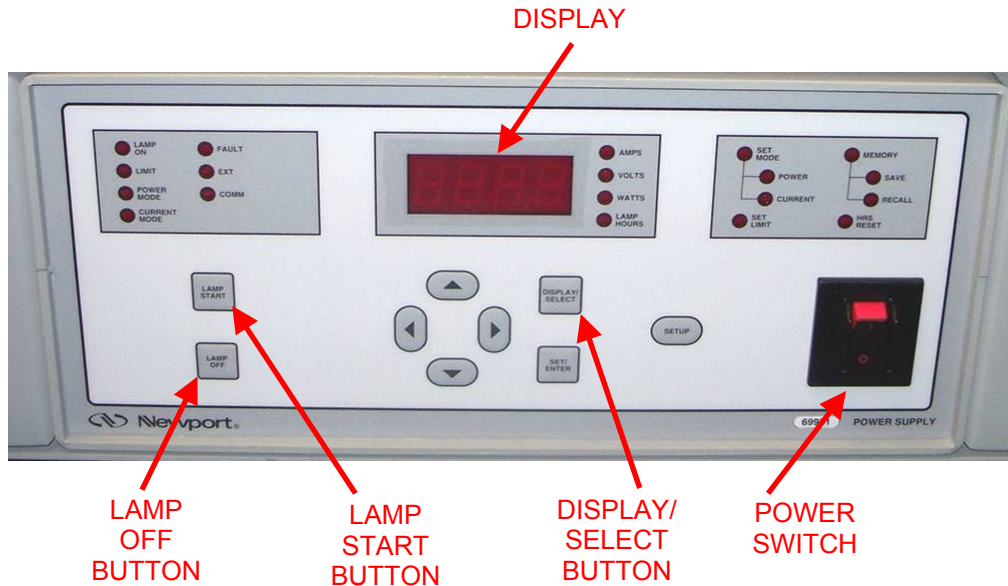

**Figure 11: Power Supply Front Panel**

## 5 SAMPLE POSITIONING

---

Place the test sample on the platform and adjust its position so that the green light is in the region of interest. For testing purposes, the light should be placed in between the metallic traces, as shown.

When the integrating sphere is in place, use the light bias holder as a viewing port. If probing is required, the sample may be moved down very slightly or the integrating sphere may be removed. A sample may be held in place on the Oriel temperature controlled vacuum chuck (model IQE-TC-VAC) . IQE probe kits (model PVIV-PROBE-KIT) can be used to take data.

Ensure that the sample surface is perpendicular to the light path to obtain accurate reflectance readings. Also ensure that the entire light spot is on the active area of the sample. The surface of the sample must be placed in the focal plane of the output beam. The focal plane is 50 mm below the beamsplitter assembly on standard systems. Custom systems will have the distance specified when the system was first quoted. In systems that are equipped with an integrating sphere, the focal plane is 100 mm from the output of the beamsplitter assembly.

When testing translucent test samples or using the low reflectance standard during calibration, place a piece of light absorbing black-out material underneath to prevent reflections from the sample platform. A square piece of this material is provided with the system.

Adjust the height by turning the knobs on the platform holder. The left knob locks / unlocks the platform and the right knob is rotated to raise or lower the platform. Minimal lubricant is used on the post holding the platform to help prevent contamination of samples, so it is a good idea to support the platform with one hand underneath it when changing its position with the adjustment knob to reduce vibration. For fine height adjustments, use the Z-axis micrometer.

A BNC cable in the sample compartment is used to connect the test sample to the IQE system multiplexer. The sample cable on AC systems terminates in a BNC female connector. On ACDC systems, the cable terminates in a BNC male connector with a removable BNC female adapter. Each optional IQE probe terminates in a 2mm pin tip connector, which could be mated to a terminal block on the temperature controlled vacuum chuck.

The IQE system comes with the following cables, to aid with sample connection:

- BNC male to BNC male
- BNC male to micrograbber clips
- BNC male to alligator clips

Due to the wide variety of test sample construction, it is ultimately the end user's responsibility to devise connections to their samples. Oriel Instruments does offer a variety of connection options to aid customers. Refer to Appendix I for a listing of adapters and cables which can be purchased separately.

The polarity of the connection is dependent on the construction of the test sample. To verify the correct polarity of the cabling, set the monochromator to a wavelength which the test sample is known to have good response. Very little or no signal from the test sample at that wavelength is a sign that the polarity connections are reversed and the two connections must be swapped.

One quick method to switch the polarity while minimizing disturbance to the sample is to use two BNC to double banana connectors between the test sample to the sample BNC cable. Reversing one of the banana plugs will change the polarity.

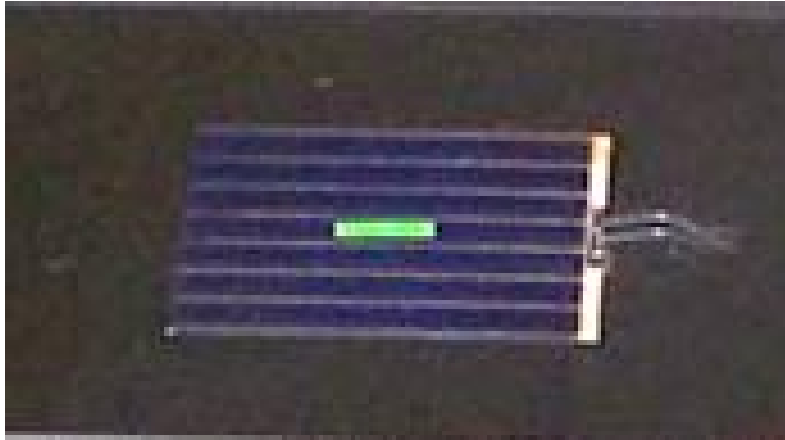

**Figure 12: Sample Positioning**

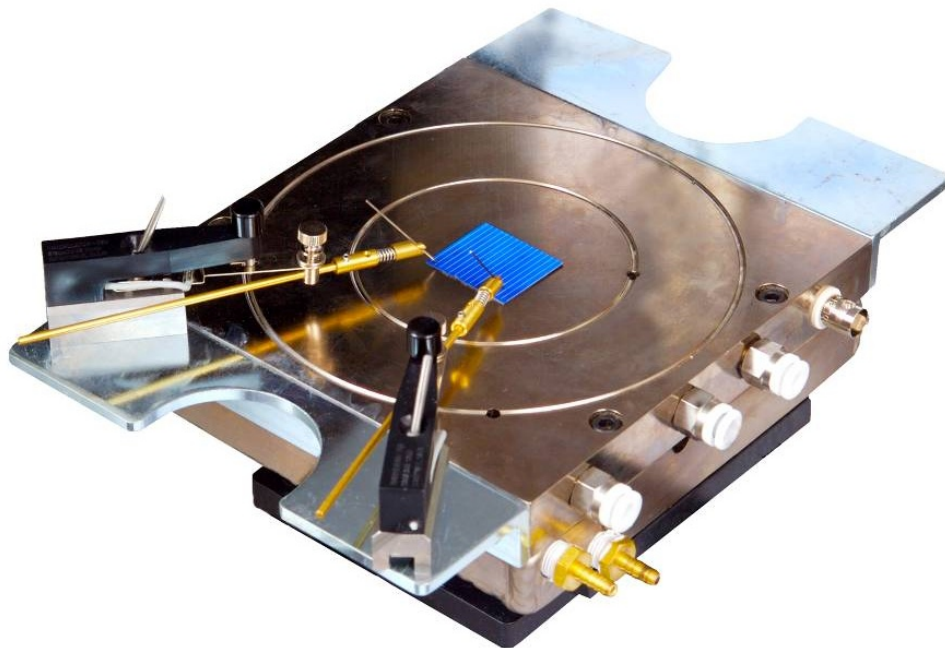

**Figure 13: Sample Probing**

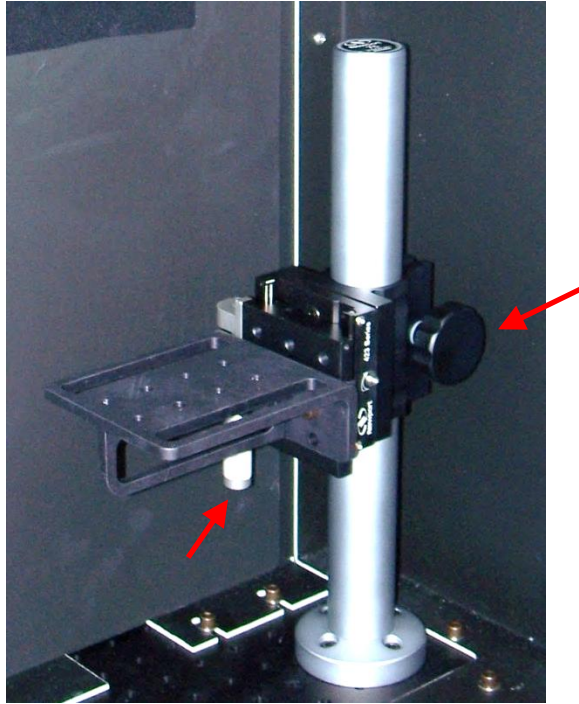

**Figure 14: Basic Test Sample Platform**

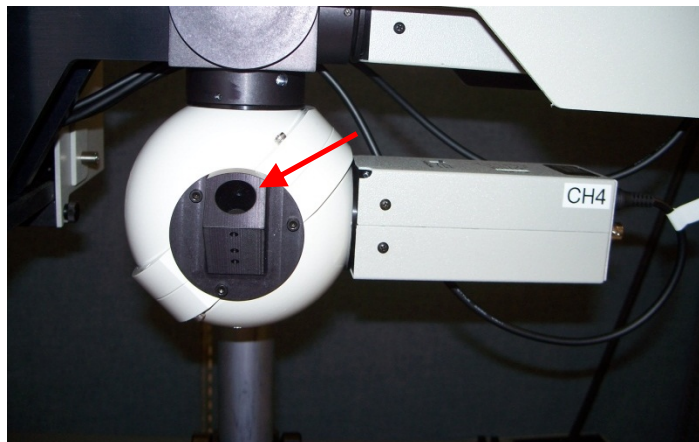

**Figure 15: Light Bias Fiber Holder**

## 6 STANDARDS

### 6.1 DETECTOR STANDARDS

The IQE system comes with two calibrated sample detectors. They are used for system verification and calibration. Each detector is labeled according to its type and each has a unique responsivity curve. These detectors have been matched to this IQE system.

The silicon detector is part number IQE-SAMPLE-SI. It operates from 300 nm to 1100 nm and has a 10 mm square element. The germanium detector is part number IQE-SAMPLE-GE. It operates from 800 nm to 1800 nm. This detector has a 5 mm round element. The germanium detector is included only with extended range systems.



**Figure 16: Sample Detectors**

Care should always be taken not to touch the photodiode window or reflectance standards with bare fingers. Contaminants may cause inaccurate measurements, particularly at ultraviolet wavelengths where absorption is common. Lightly clean the detector window with a soft, lint-free cloth and isopropyl alcohol. Cover when not in use.

Oriel Instruments calibrates its detectors using standards directly traceable to the United States National Institute of Standards and Technology (NIST). Calibration involves illumination of central region of the detector active area. Fabrication processes may cause the response of the detector to vary slightly over the detector surface. Optical signals being measured by the system should illuminate the same central area.

## 6.2 SPECULAR REFLECTANCE STANDARDS

The IQE system comes with two samples which have known specular reflectances. They are used for system verification and calibration. The low specular reflectance standard is a square piece of black glass. The high specular reflectance standard is a mirror. These samples have been matched to this IQE system.

Care should always be taken not to touch the samples with bare fingers. Contaminants may cause inaccurate measurements, particularly at ultraviolet wavelengths where absorption is common. If necessary, lightly clean them with a soft, lint-free cloth. Keep these items in their plastic cases when not in use.

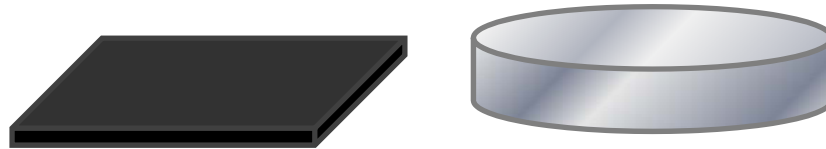

Figure 17: Specular Reflectance Standards

## 6.3 DIFFUSE REFLECTANCE STANDARDS

When equipped with the integrating sphere option, an IQE system also includes two samples which have known diffuse reflectances. They are used for system verification and calibration. The low diffuse reflectance standard is black, and the high diffuse reflectance standard is white. These samples have been matched to this IQE system.

These samples are extremely difficult, if not impossible to clean. Care should always be taken not to touch the samples with bare fingers. Contaminants may cause inaccurate measurements. Keep these items with their covers in place when not in use.



Figure 18: Diffuse Reflectance Standards

## 7 QUICK-START GUIDE

### 7.1 SCANNING A SAMPLE

After the system has been installed in its final location, a verification must be performed prior to scanning any samples. Ensure sure that the lamp has had adequate time to warm up before scanning a sample (one hour is ideal). Run the IQE200 software by double clicking on the computer desktop shortcut. Verify that green light is being emitted from the system onto the sample platform.



Place a sample to be tested on the platform and adjust its position so that the green light is in the region of interest. Ensure that the sample surface is perpendicular to the light path. Also ensure that the entire light spot is on the sample.

The surface of the sample must be placed in the focal plane of the output beam. Refer to the Sample Positioning section of this manual for more information. When testing translucent test samples, place the piece of light absorbing black-out material supplied with the system underneath to prevent reflections from the platform.

From the Home screen in the software, click Start.

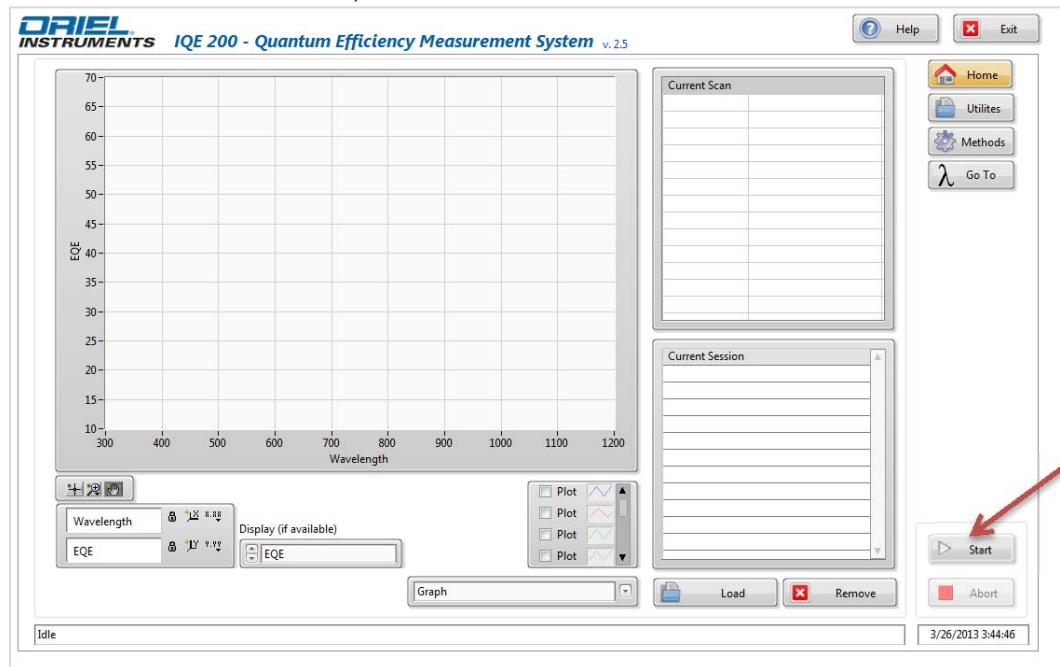
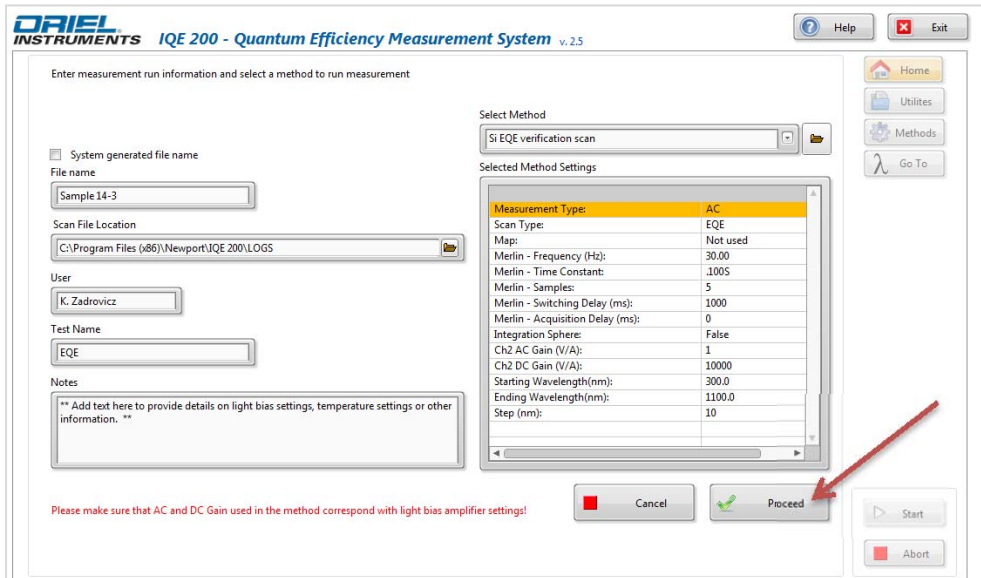
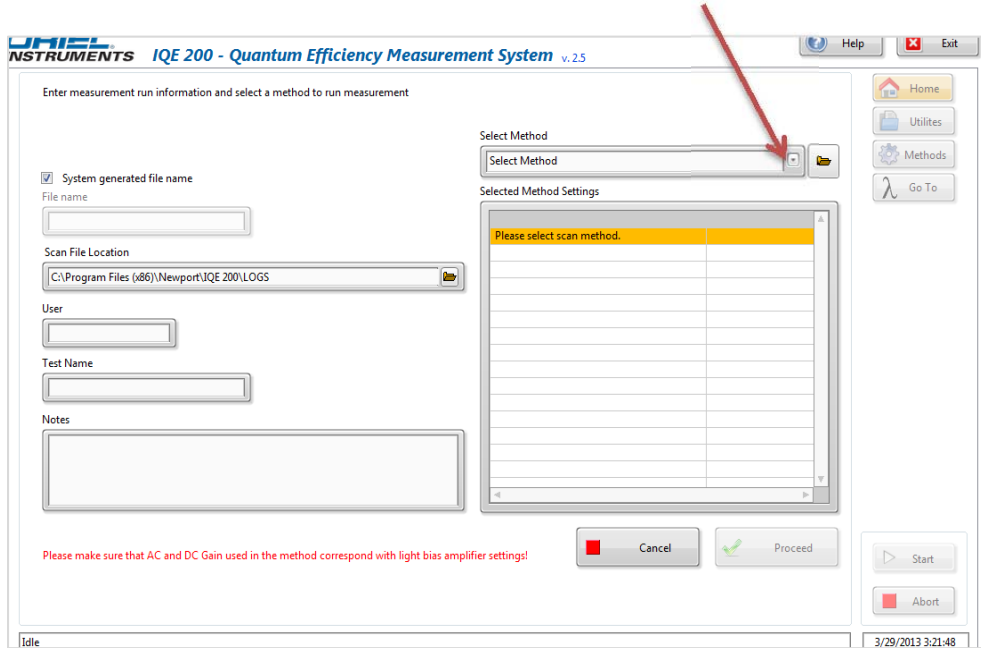

**Figure 19: Starting a Scan**

Scan parameters are saved as Methods in the software. Select the Method to be used from the pull down menu.

The user has the option to enter scan information on the left side of the screen. By default, a system generated file name will be created for the scan file. By unchecking the system generated file name option, the user can enter a custom file name.

Click Proceed to start the scan.



**Figure 20: Selecting Scan Method**

The software will return to the Home screen. The monochromator grating and filter will be positioned as needed for the starting wavelength specified in the Method.

As the scan proceeds, the results will appear in the graph on the Home screen. The user can change the display to view the EQE or other parameters, such as the spectral responsivity while the scan is running.

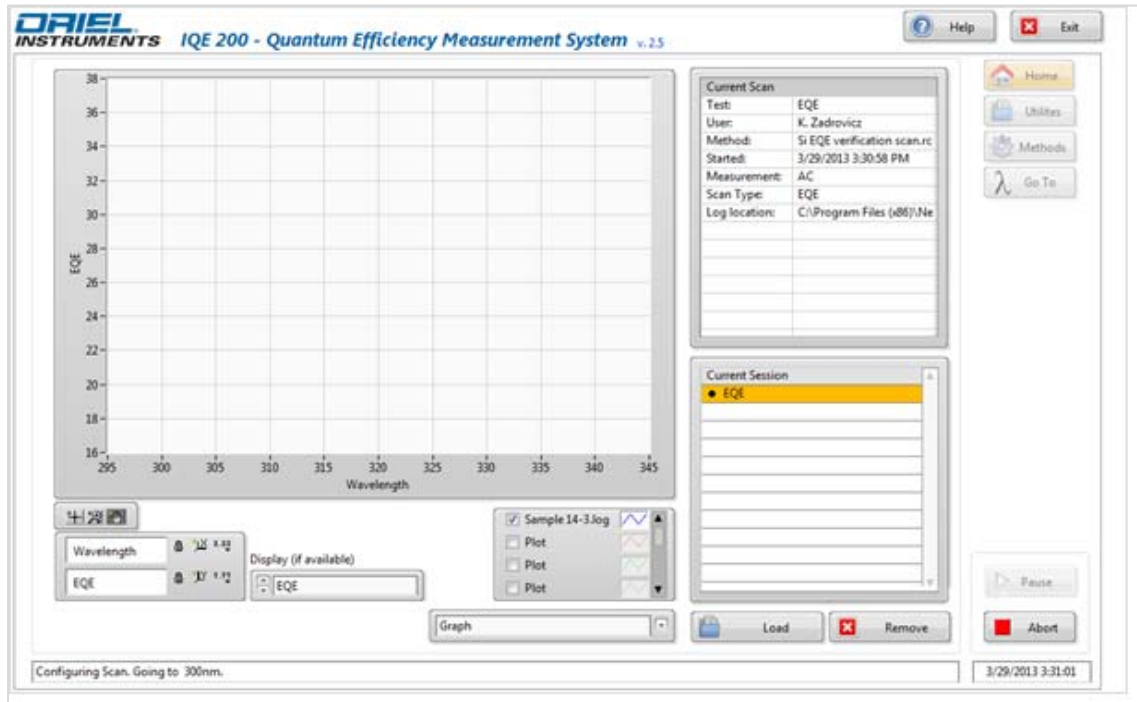

**Figure 21: Scan In Progress**

The scan may be terminated at any time by clicking the Abort button. If the scan is completed, the information will automatically be saved as a .log file. The scan information, if entered by the user, will be displayed at the top of the .log file.

The .log file data can be viewed in the IQE software, in a text editor program such as Windows Notepad or in a spreadsheet program such as Microsoft Excel.

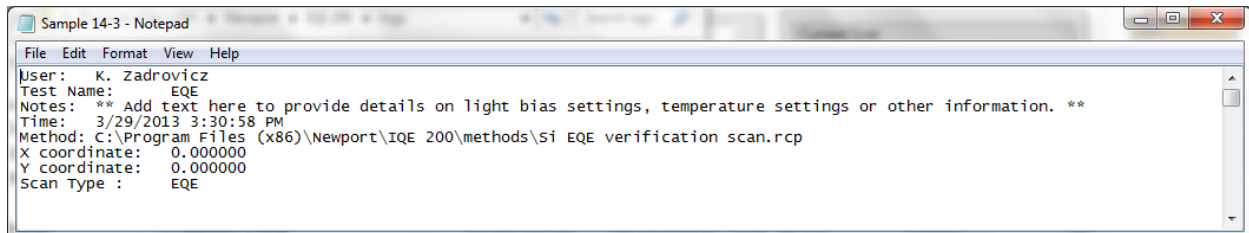

**Figure 22: Log File Header**

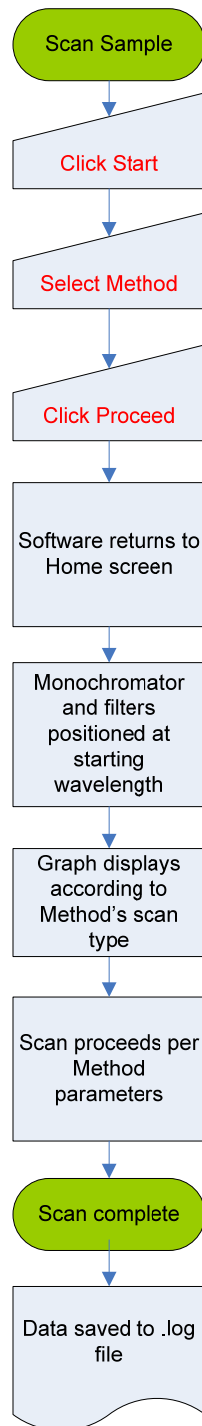

**Figure 23: Scan Process Flowchart**

## 7.2 LOADING A PREVIOUSLY SAVED SCAN

From the Home screen, click the Load button. The screen will change as shown below, allowing log files to be selected for viewing in the IQE200 software.

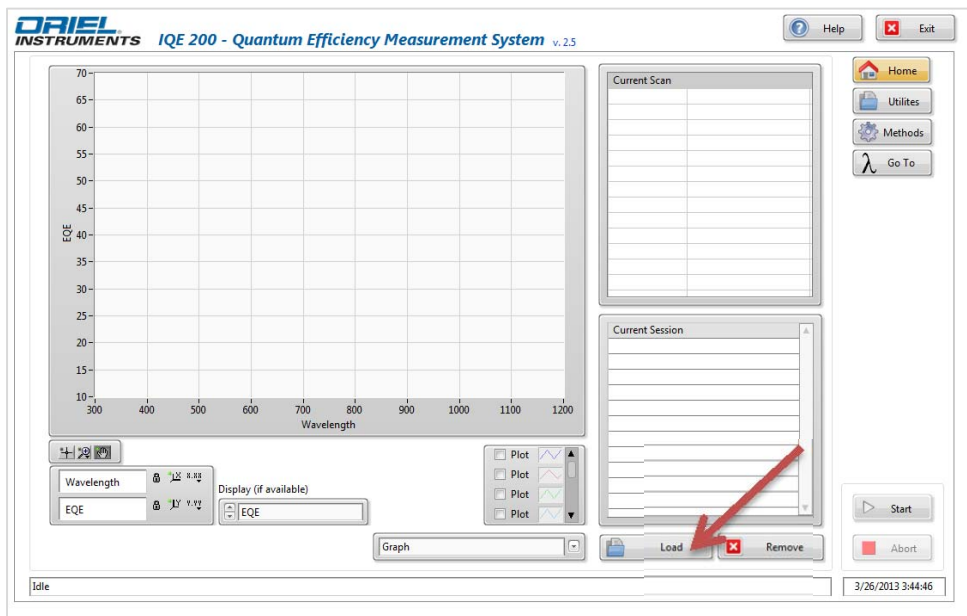

Figure 24: Load File From Home Screen

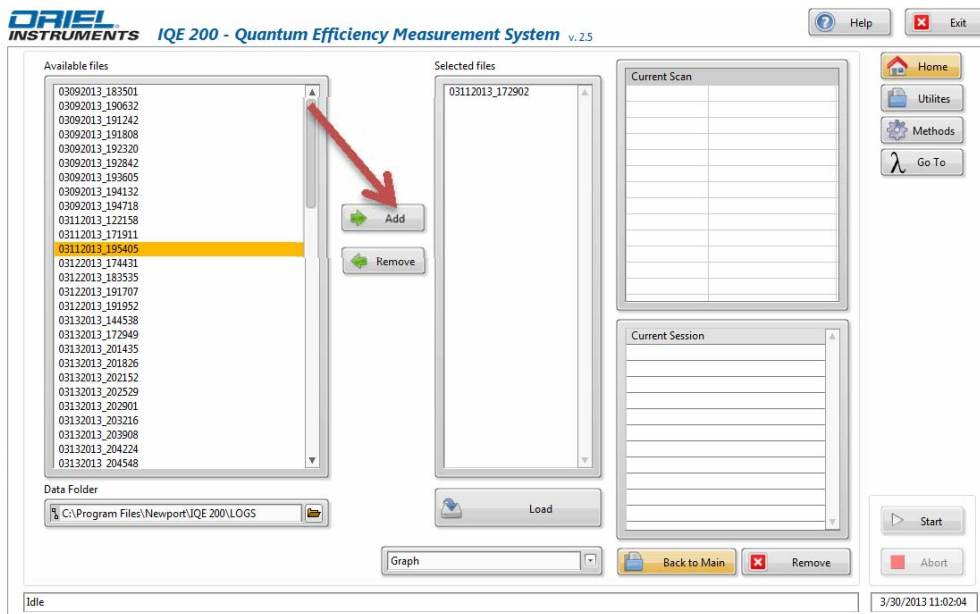

Figure 25: Selecting Files To Be Loaded

Click on a scan so that it is highlighted, then click Add to bring it into the Selected Files field. Multiple scans may be selected in a group by holding down the Shift key or the Ctrl key, as is done in Windows. Up to twenty files may be selected at once.

At any time in the load screen, if one wishes to return to the Home screen without loading any files, click the Back To Main button.

After all files desired have been added to the Selected Files field, click the Load button. The software will then return to the Home screen and the files will be loaded. The default view is the EQE Graph. Choose a different display if another parameter is to be examined.

The graph view may be changed to a tabular view. In this view, only one scan can be displayed at a time. Choose the scan from the list of loaded log files.

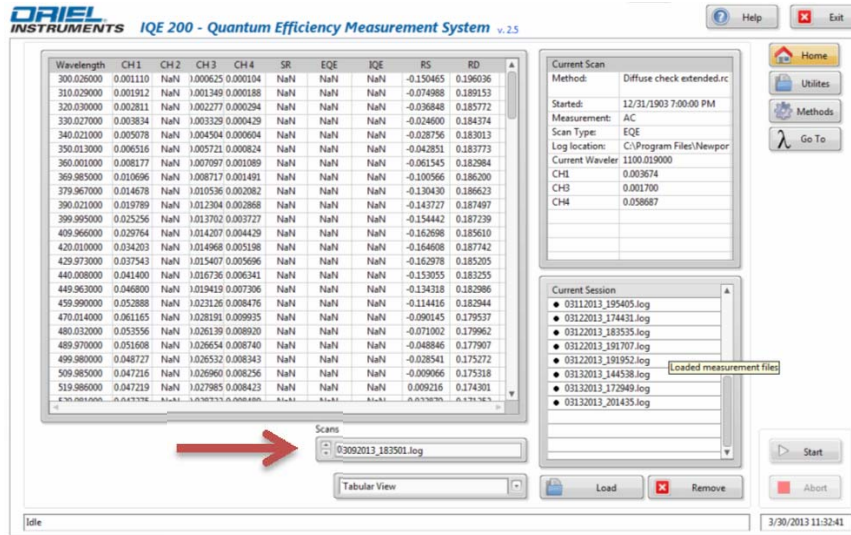

Figure 26: Tabular Display of Loaded Log File

## 8 SYSTEM VERIFICATION

### 8.1 VERIFICATION PROCESS

Be sure that the lamp has had adequate time to warm up before verifying system performance.

After being built and calibrated, each system has final data taken at Oriol Instruments prior to shipment. This data is saved on the laptop computer that is shipped with the IQE system.

Data is located in the Logs folder which is located at:  
C:\Program Files\Newport\IQE 200\logs

Prior to shipment of the system, scans are completed using the detector standard(s) and the high reflectance standard. The types of scans that were performed is dependent on the system configuration.

Log File	Method Used	Applicable Systems
Final data EQE AC - Si sample.log	Si verification - EQE AC.rcp	All models
Final data EQE DC - Si sample.log	Si verification - EQE DC.rcp	All ACDC models
Final data EQE AC - Ge sample.log	Ge verification - EQE AC.rcp	Extended range AC and ACDC models
Final data EQE DC - Ge sample.log	Ge verification - EQE DC.rcp	Extended range ACDC models
Final data - high reflectance.log	Reflectance Check 10 nm steps.rcp	All models



**Figure 27: Final Data Log Files**

To verify performance of the system, follow the instructions in this manual to load and view final data scan data. The types of scans taken are referred to as “Methods.” Re-run the same scans and compare the data.

A verification scan should be run any time there is a question about whether a system requires recalibration. Examples of these situations would be if the slit size is altered, the system is transported, the lamp is replaced or other maintenance is performed or as a regular scheduled check.







If the new scans match the factory data to within the specifications of the system, no further action is needed. If the scans do not match, refer to the following section on lamp optimization. If that does not resolve the problem, consult the troubleshooting section of this user’s manual for possible causes of measurement error.

If the facility has or will have multiple IQE systems, store the sample detector(s) and reflectance standards with their respective systems to avoid confusion. If there is any question as to which detectors are matched to the system, check the calibration data for the detectors under C:\Program Files\Newport\IQE 200\configuration\Calibration Standards. The sample detector file names indicate their serial numbers. The numbers at the beginning of the files names for the specular reflectance standards are written on their cases.

Name	Date modified ▾	Type	Size
 Final data EQE AC - Si sample.log	3/25/2013 11:03 PM	Text Document	6 KB
 Final data - high reflectance.log	3/25/2013 11:03 PM	Text Document	5 KB
 Final data EQE DC - Si sample.log	3/25/2013 11:02 PM	Text Document	6 KB

3 items

**Figure 28: Final Data Files for ACDC Standard Range System**

Name ^	Date modified	Type	Size
 7g high reflectance 09 11 12.txt	9/11/2012 5:31 PM	Text Document	3 KB
 11g low reflectance 09 11 12.txt	9/11/2012 5:29 PM	Text Document	3 KB
 high diffuse reflectance std 09 12 12.txt	9/21/2012 9:21 PM	Text Document	2 KB
 IQE-SAMPLE-GE_..._001.txt	9/11/2012 1:36 PM	Text Document	2 KB
 IQE-SAMPLE-SI_..._001.txt	9/21/2012 3:36 PM	Text Document	2 KB
 low diffuse reflectance std 09 12 12.txt	9/21/2012 9:22 PM	Text Document	2 KB

6 items

**Figure 29: Calibrated Detector Files for Extended Range System with Integrating Sphere**

## 8.2 LAMP OPTIMIZATION

If the verification scan does not match the final data taken by Oriel Instruments, the lamp should be checked to ensure that it is in the optimal position.

Load a factory data scan and a verification scan. Change the display to Channel 1. This shows the voltages present at the reference detector. This voltage should be consistent no matter which type of Method or sample is used.

Compare the two graphs to ensure that they overlap reasonably well over the entire range of operation. The Figure shows the reference detector voltage on a system using a xenon lamp and Si reference detector. The peaks are the xenon emission lines. If a QTH lamp were to be used, these spikes would not be present. Note that some minor variation in the height of the peaks is expected.

**Oriel**  
**INSTRUMENTS** IQE 200 - Quantum Efficiency Measurement System v.2.5

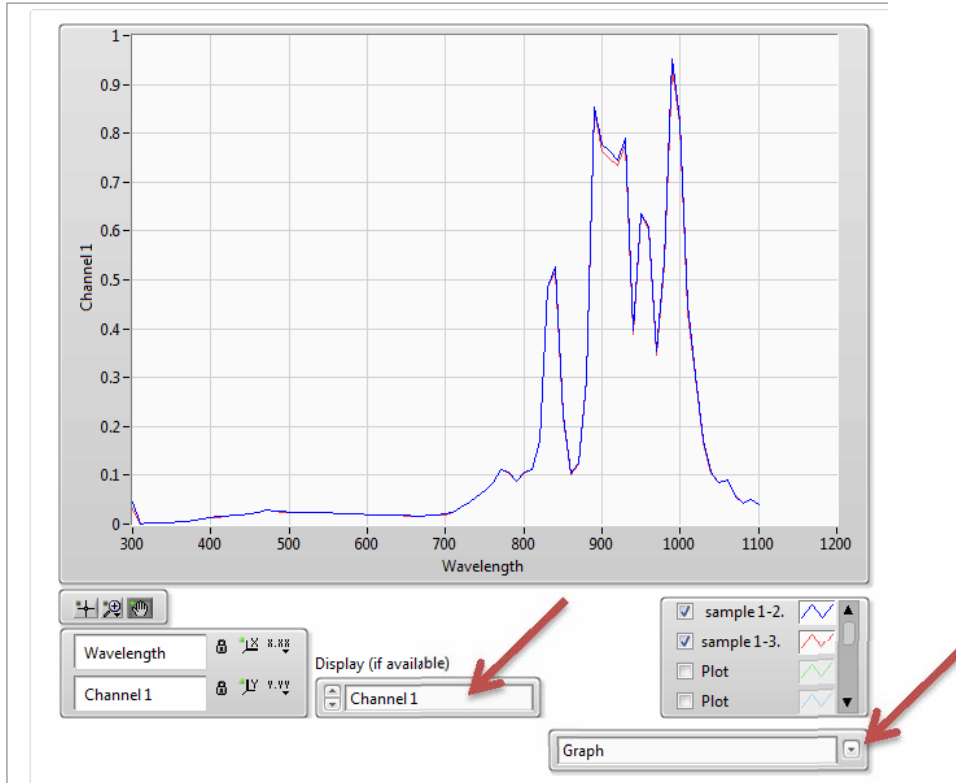

Figure 30: Reference Detector Voltage Comparison Graph

Read the voltage values at specific wavelengths.

Voltage readings are given for Channel 1, 2, 3 and 4 at a series of wavelengths. The detector channels are noted below.

- Channel 1 = Reference Detector voltage
- Channel 2 = Sample voltage
- Channel 3 = Rs detector voltage
- Channel 4 = Rd detector voltage (if integrating sphere is used)

For standard range systems with a xenon lamp, note the voltage at 300 nm. For those with a QTH lamp, note the voltage at 360 nm. If the system is extended range, note the channel 1 voltage at 1800 nm.

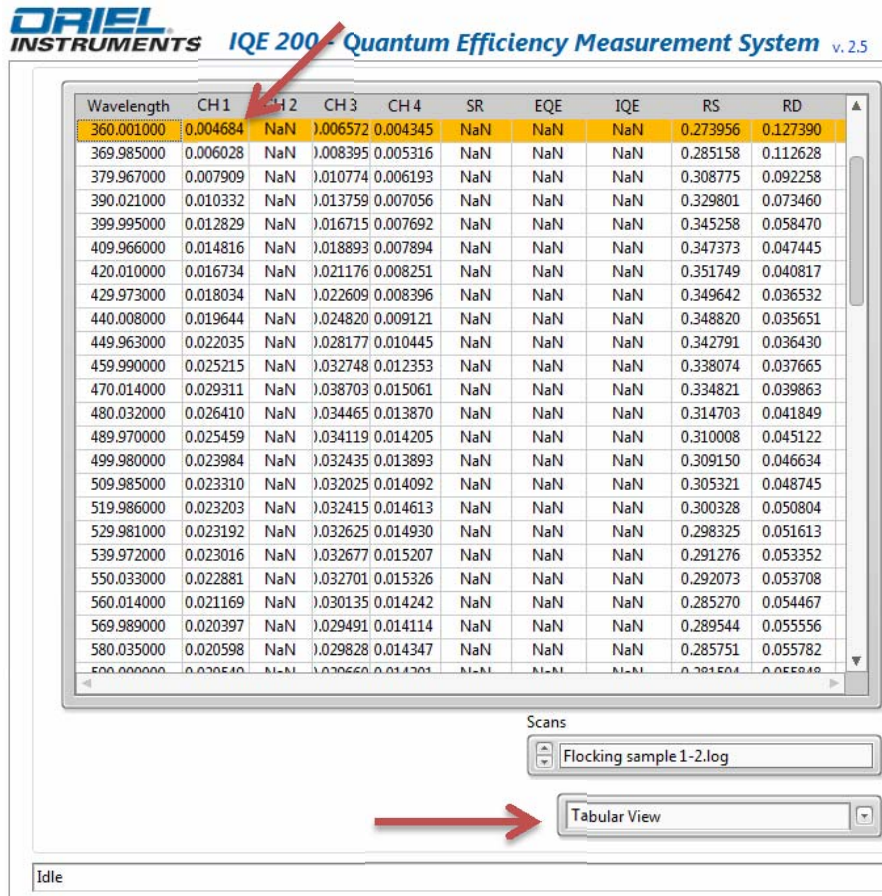
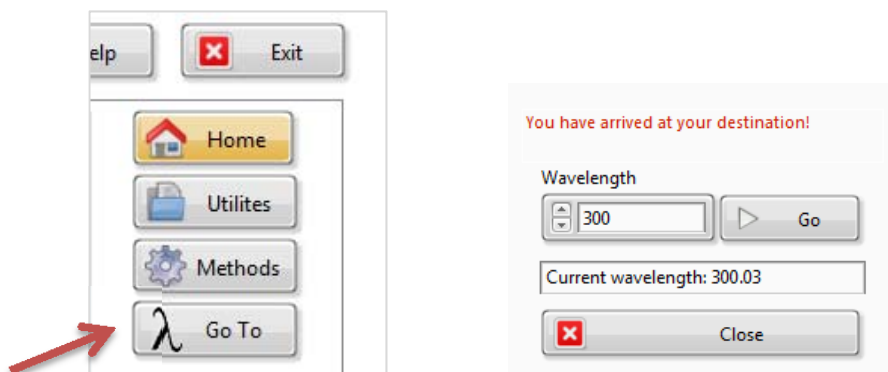

Figure 31: Reference Detector Voltage Table

Click the Go To Wavelength ( $\lambda$ ) button. A small window will appear which allows the user to control the monochromator to output a selected wavelength in nm.

Enter the wavelength for which the voltage was just noted (i.e. 300 nm, 360 nm or 1800 nm) and click Go. The monochromator must select the correct diffraction grating and filter in order to output the requested wavelength. A "Please wait" message will appear in the window while these actions are being performed. Once the monochromator has reached this wavelength, close the wavelength dialogue box.



**Figure 32: Select Wavelength**

The light must be chopped in order to continue with lamp optimization. If the system is ACDC, be sure that the chopper controller display is set to 30 Hz.. If it is not, refer to the chopper controller settings section of this manual.

Click the Utilities icon.



**Figure 33: Select Utilities**

The initial view will display the monochromator settings. Choose to display the multiplexer settings.

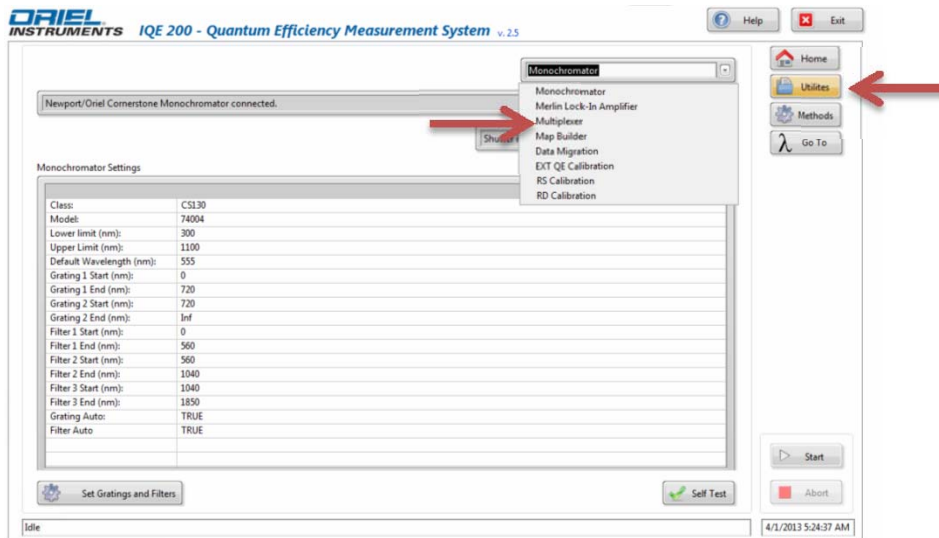

**Figure 34: Selecting the Multiplexer Utility**

Select Channel 1 as shown below. If operating an ACDC system, ensure the data is being read from the Merlin™ lock-in amplifier.

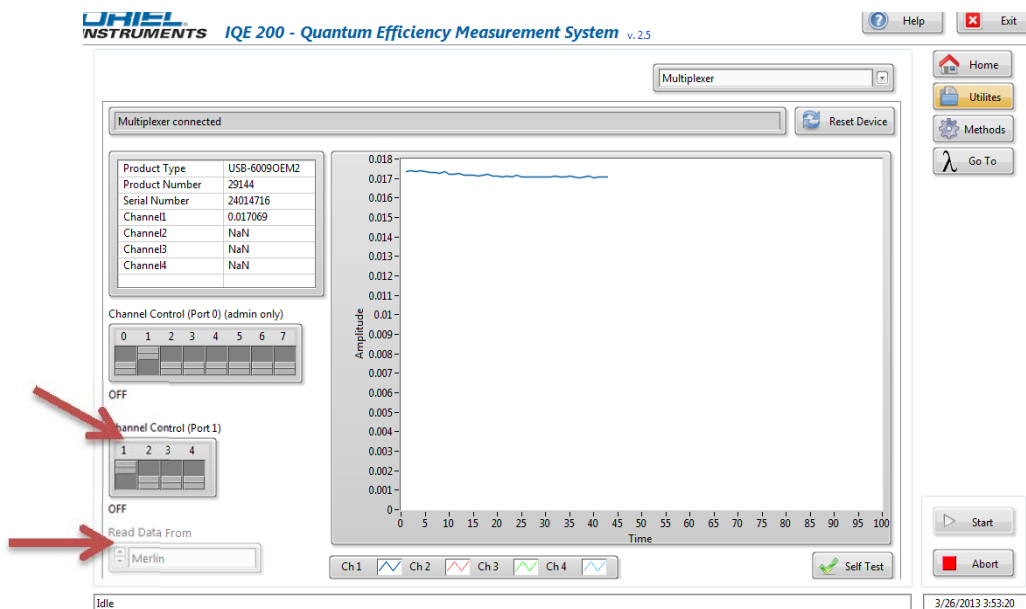

**Figure 35: Multiplexer Utility Screen**

Once Channel 1 is selected in the multiplexer utility, the front display of the Merlin™ lock-in amplifier will show the voltage that is being read by the reference detector. The same voltage should be displayed in the multiplexer utility screen of the software.

Check to see if the voltage being displayed is close to the voltage noted for Channel 1 at the wavelength noted in the log file. If necessary, optimize the light source to match the voltages as closely as possible. Be sure that the lamp has been allowed to warm up completely so that its output is stable prior to comparing voltages.

To optimize the light source, unlock the lamp vertical position adjustment knob. Make very, very gradual adjustments to change the voltage. Then unlock the lamp horizontal position adjustment knob and make the same adjustments, if necessary. It is very important to turn the knobs one at a time and as slowly as possible. When checking the change in the voltage, no contact should be made with the knobs.

When finished, be sure to lock the adjustment knobs. Making adjustments to the rear reflector knobs and lamp housing condenser barrel should be attempted very cautiously, and only when absolutely necessary. Typically this is not necessary.

After the lamp position has been optimized, run verification scans to ensure that the data matches the scans taken at Oriel Instruments prior to the instrument shipping out.

## 9 ADVANCED SYSTEM CONFIGURATION

### 9.1 CHOPPER CONTROLLER SETTINGS (ACDC SYSTEMS ONLY)

The chopper controller is set to 30 Hz at the factory.

Press the STOP OPEN button on the chopper controller for DC measurements. Press the RUN button to start the chopper turning again for AC measurements.

When RUN is pressed or the frequency is changed by pressing the SET button, a “LOCng” message appears. This indicates that the chopper controller is attempting to lock on to the frequency. Once the set frequency has been reached, the LOCng message will be replaced by the frequency in Hz on the display.

Note: after pressing Run, always wait for the chopper to lock in the frequency before starting any AC scans. When it is locked in to the frequency, the frequency is displayed in Hz.



Figure 36: Chopper Running



Figure 37: Chopper Stopped

## 9.2 INTEGRATING SPHERE OPTION

When the sphere is in use, the port in the front should be used to view the test sample for correct placement. If the light biasing system is to be used, the port opening holds a fiber optic cable securely with three set screws.

The integrating sphere may be removed from the IQE system as needed for probing of test samples. The Method selected when running a scan must reflect whether the sphere is installed or not.

To remove sphere assembly, disconnect the cable from the Channel 4 detector. Leave the detector itself attached to the sphere. Loosen the three set screws at the bottom of the beamsplitter assembly while supporting the sphere from underneath in order to disconnect it from the system. When the sphere is not in use, cover the ports to prevent contamination of the inside surface.

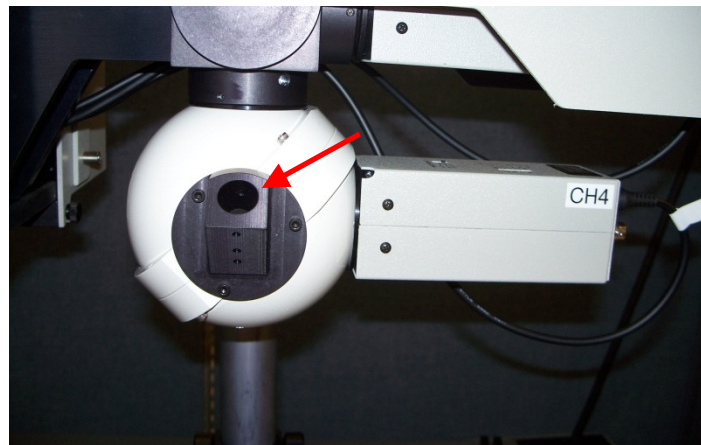

**Figure 38: Optional Integrating Sphere with Light Bias Fiber Holder**

### 9.3 LIGHT BIASING OPTION

Oriel Instruments offers a light biasing system designed for use with the IQE200 (model IQE-LIGHT-BIAS).

One fiber optic cable can be used for white light biasing or for use with a single filter during multi-junction cell biasing. When two filters are needed, such as for biasing the middle junction in a 3-junction cell, a bifurcated comb randomized fiber optic cable can be used. The split ends can be connected to two filtered light sources, and the single end connected to the integrating sphere.

To employ light biasing when an integrating sphere is not being utilized, an adapter ring is provided with the light biasing system. This ring fits onto the bottom of the beamsplitter assembly and has holders for two fiber optic cables. Refer to the light biasing system manual for more information.

The filters required for biasing multi-junction cells vary by application. Therefore, these filters are sold separately.



**Figure 39: Optional Light Bias System**

## 9.4 GAIN ADJUSTMENTS

The light bias amplifier (model 70714) is located in one of the equipment drawers of the IQE system. Sometimes it is necessary to change the gain on the test sample signal. Separate switches are located on top of the light bias amplifier for AC gain and DC gain. Refer to Figure 40.

Note: when adjusting the gain switches, the method used must have matching parameters..

Gain switches are also located on the detectors attached to the beamsplitter assembly and integrating sphere or their amplifiers. The IQE system was calibrated with these gain switches set to their current locations. Do not change these switch settings.

Refer to the light bias amplifier user's manual for more information.

## 9.5 VOLTAGE BIASING

To apply a positive DC bias voltage to the test sample, an external voltage source may be connected to the light bias amplifier (model 70714). The light bias amplifier is located on one of the IQE system's equipment drawers.

Refer to the light bias amplifier user's manual for more information.



Figure 40: Light Bias Amplifier

## 9.6 LIGHT SPOT SIZE ADJUSTMENT

Micrometer-driven adjustable slits are mounted at the input and output ports of the Cornerstone monochromator. The micrometers are used to adjust the width of the apertures. They have been set at Oriel Instruments so that the system's detectors and samples do not become saturated by excessive light levels.

The power level at which a test sample saturates will vary based upon its properties. With the continuous development of new materials, the saturation level can be difficult to predict. Therefore it is important to be able to recognize when an unusual scan result may be the result of test sample saturation. Refer to the troubleshooting section of this manual for more information.

To eliminate the problem of saturation, one would need to reduce the amount of light that is incident on the test sample. This can be accomplished by narrowing the slit width at the output of the monochromator. Alternatively, one may try lowering the DC gain on the light bias amplifier if the "DC Gain Too High" fault light is lit on the light bias amplifier.

Slightly changing the output slit width (the one closer to the beamsplitter) should not affect the system calibration. However, changing the input slit width would likely require recalibration of the IQE system. Therefore, it is not suggested to change the input slit width unless it is absolutely necessary to reduce the power incident on the test sample.

Note: to be certain that measurement errors will not be introduced, run a verification scan.

The slit is adjustable from completely closed to 3 mm wide. Use a 10x multiplier to convert the micrometer reading to the slit opening size in  $\mu\text{m}$ . For example, turning the micrometer handle from 0 to 1 adjusts the slit from completely closed to 10  $\mu\text{m}$  wide.

The completely closed position is when the zero on the body of the micrometer lines up with the zero on the turning portion, as shown in Figure 42. One complete revolution equals 50 on the micrometer (500  $\mu\text{m}$ ).

A change in the slit width will alter the resolution of the monochromator. Refer to the section on monochromator resolution for more information.

## 9.7 MONOCHROMATOR RESOLUTION

Use the following formula to determine the effect of monochromator input slit width on the resolution of the instrument. Note that for legacy standard range systems, the grating dispersion may be different. Contact Oriel Instruments or the regional sales representative for information, if desired.

$$\text{Slit Width (mm)} \times \text{Reciprocal Dispersion (nm/mm)} = \text{Resolution at blaze wavelength}$$

Grating	Wavelength Range	Reciprocal Dispersion	Blaze Wavelength
#1	300 nm to 720 nm	13.3 nm/mm	400 nm
#2	720 nm to 1800 nm	13.0 nm/mm	1000 nm

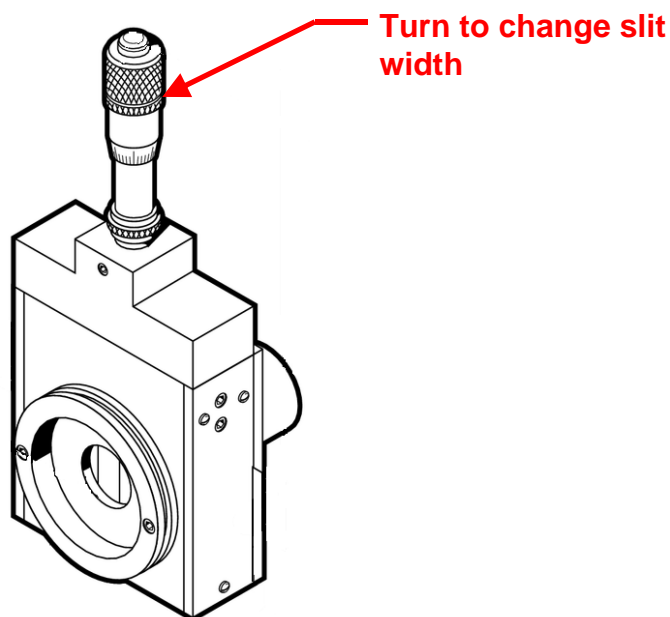

Figure 41: Micrometer Driven Slit

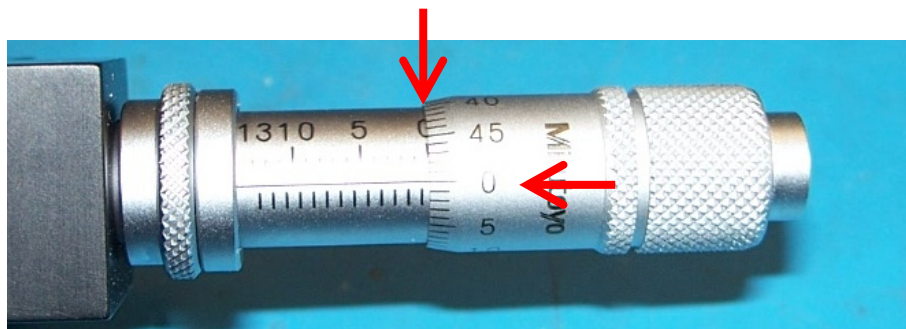

Figure 42: Micrometer Reading In Closed Position

## 10 SOFTWARE

### 10.1 HOME SCREEN OVERVIEW

When the software is started, the monochromator is commanded to go to 555 nm. This allows the user to visually orient a test sample on the sample platform. When all instruments are initialized and the monochromator is at 555 nm, the Home screen appears.

The various areas of the Home screen are detailed on the following pages.

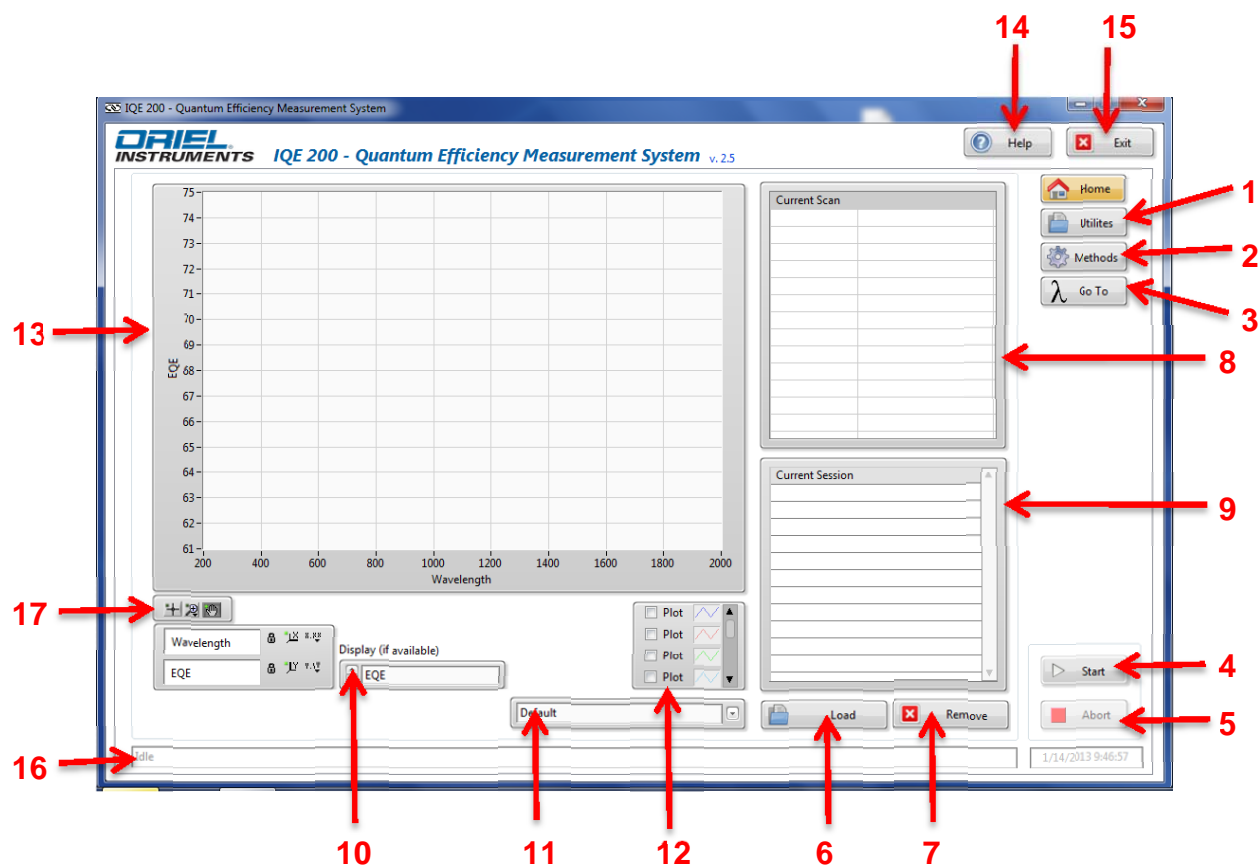

Figure 43: Home Screen

The Home screen is made up of the following:

1. Utilities  
This allows the user to access settings for the instruments that make up an IQE system, as well as perform calibrations.
  2. Methods  
The Methods Editor is used to create, save and edit scan parameter settings.
  3. Go To  
This button opens a dialogue box which displays the current wavelength and allows the user to command the monochromator to go to a different wavelength.
  4. Start  
When ready to perform a scan, clicking on this button brings the user to a different window where the user can select which Method to use.
  5. Abort  
This is used to stop a scan that is in progress.
  6. Load  
This button brings the user to a new window which saved scans can be selected for viewing.
  7. Remove  
By selecting scans in the Current Session list and clicking on this button, scans which are currently being displayed will be removed.
  8. Current Scan properties  
This area displays the properties of the Method used by the scan that is in progress.
  9. Current Session  
This area displays a list of the currently loaded scans.
  10. Display Selector  
The menu allows the user to select the graph to view in the display window for the currently loaded scans. By default, EQE is the first graph displayed when starting a new scan.
    - External Quantum Efficiency (EQE) [default view]
    - Internal Quantum Efficiency (IQE)
    - Reflectivity, Specular (Rs)
    - Reflectivity, Diffuse (Rd)
    - Spectral Responsivity (SR)
- The availability of graphs is dependent on the type of Method used. For example, a reflectance scan will not have EQE data to be displayed.
11. View Selector  
The user can choose between the default (graphical) view of the loaded scans or a tabular view. In the tabular view, the user must choose which of the currently loaded scans to display, as only one is shown at a time. If the Jsc option is chosen, the user will be prompted to load a scan which contains EQE information.

12. Graph Properties

For each scan that is currently loaded, the user can turn the graphs on or off by toggling a check mark to the left of the plot name. By clicking on the box with the colored line, the user can change graphical properties such as line color, width and style.

13. Display Window

This area is where the user can view the currently selected graph(s), table or Jsc calculations. The scale of the graph can be adjusted by manually typing starting and ending values for the x and y axes. Alternatively, graphical adjustment icons may be used instead.

14. Help

Information about the IQE system, which is provided in PDF format is opened by Acrobat Reader.

15. Exit

This button closes the IQE software. Alternatively, the “x” in the upper right corner of the software window may also be used. Scans which are not aborted are automatically saved, so no data is lost when exiting the program.

16. Status Bar

By clicking once in this field, a separate window will open displaying the status of the system.

17. Graph Zoom Controls

This feature allows the user to view specific areas of a graph.

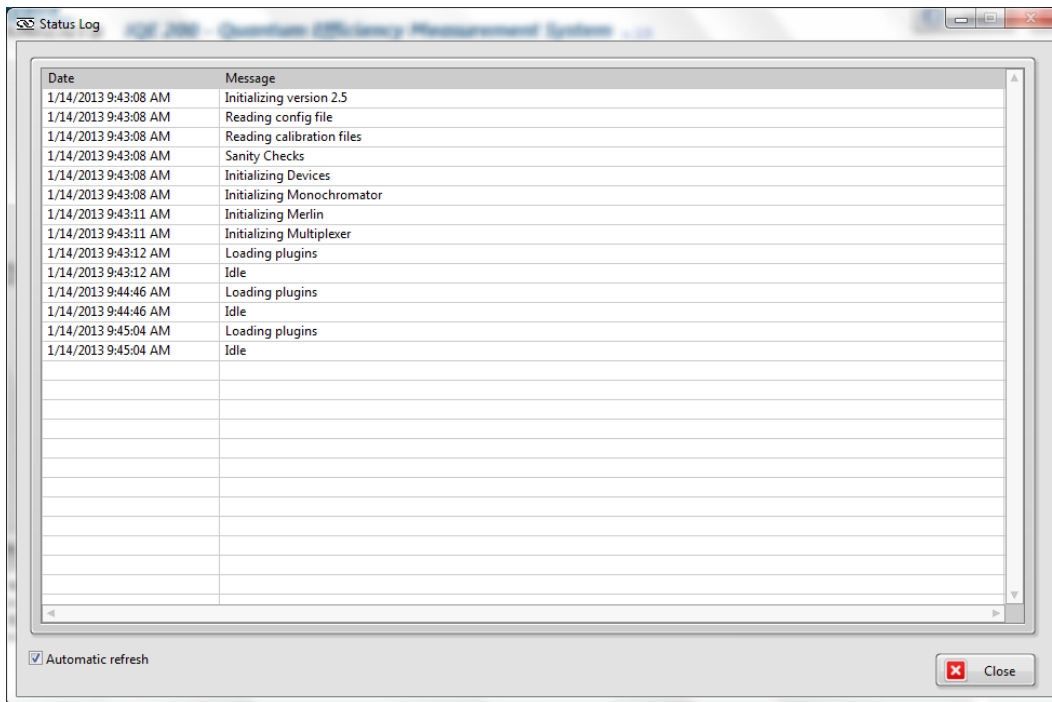

**Figure 44: Status Window**

## 10.2 DISPLAYING GRAPHS

After clicking the Load icon, the software will automatically return to the Home screen and the EQE graph will be displayed.

Clicking the up and down arrows in the Display field will allow one to view graphs for the following.

- External Quantum Efficiency (EQE) - default view
- Spectral Responsivity (SR)
- Internal Quantum Efficiency (IQE)
- Reflectivity, Specular (Rs)
- Reflectivity, Diffuse (Rd) [integrating sphere systems only]
- Total Reflectivity (Rs+Rd) [integrating sphere systems only]
- Channel 1 Voltage
- Channel 2 Voltage
- Channel 3 Voltage
- Channel 4 Voltage [integrating sphere systems only]

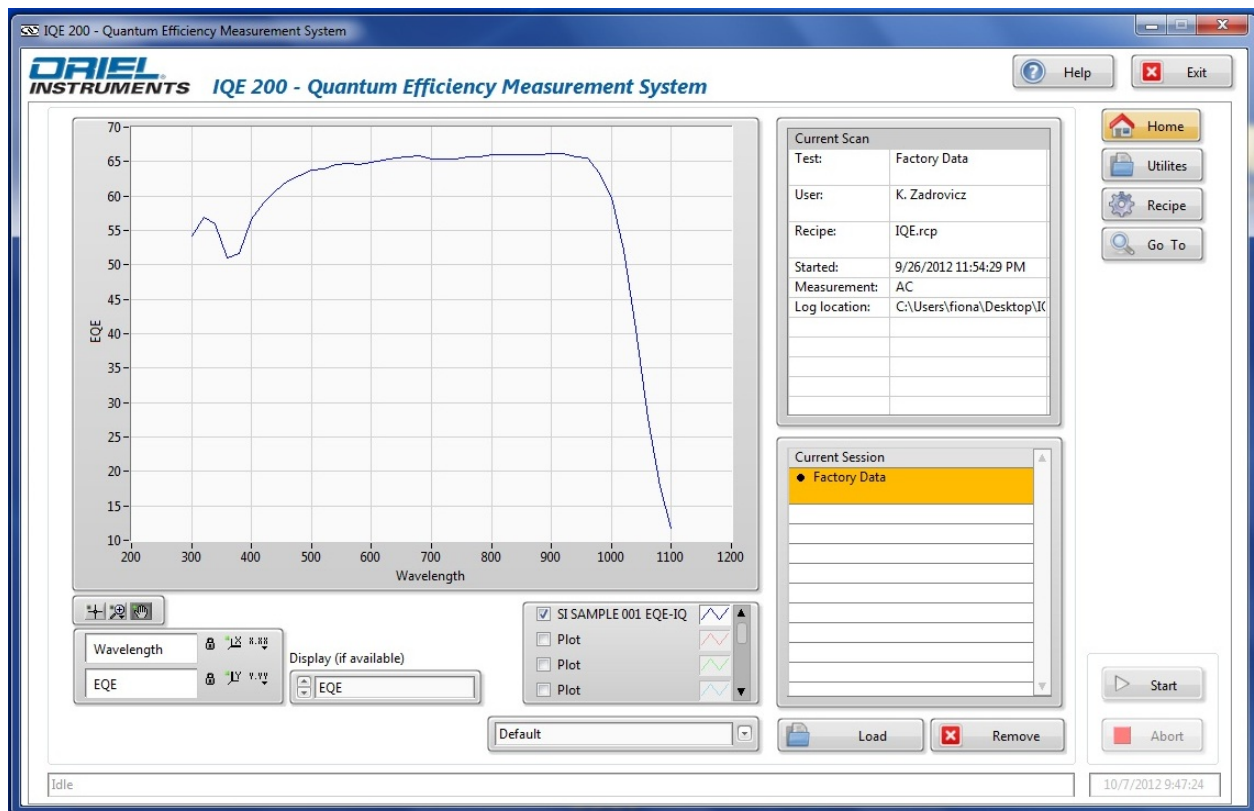
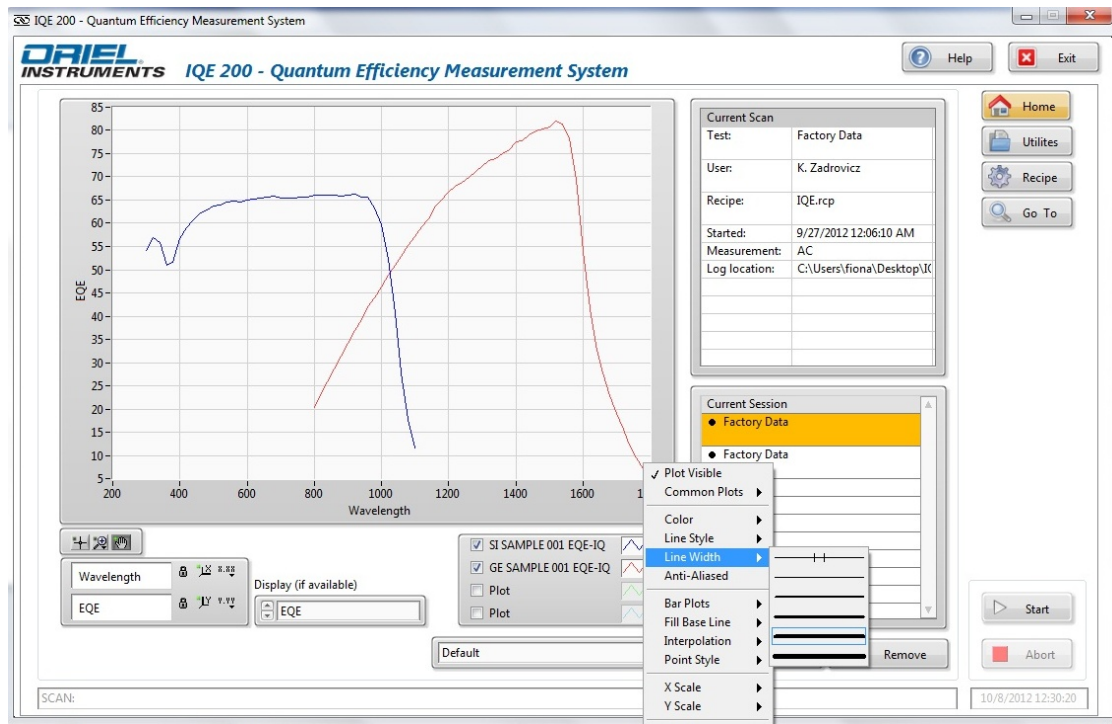

**Figure 45: Saved Scan, Default View**

Note that not all graphs will be available – it depends on the type of scan which was performed. For example, data taken using the recipe file ReflectanceWithSphere.rcp will not have an EQE graph.

If multiple scans are loaded, each will have a different color in the graph. The line weight, color and other graphical properties can be edited by clicking on the colored line to the right of the scan name.

To temporarily turn off a graph, click the check mark next to the name of the graph.



**Figure 46: Edit Graph Properties**

To remove a graph, select the graph in the Current Session list and click the Remove icon.

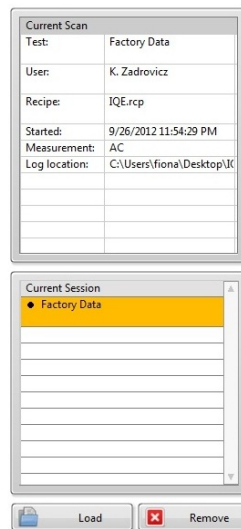

**Figure 47: Remove Graph**

To view the raw data, change the display type from Default to Tabular View. When multiple scans have been opened, use the Sessions field to choose which scan will be shown.

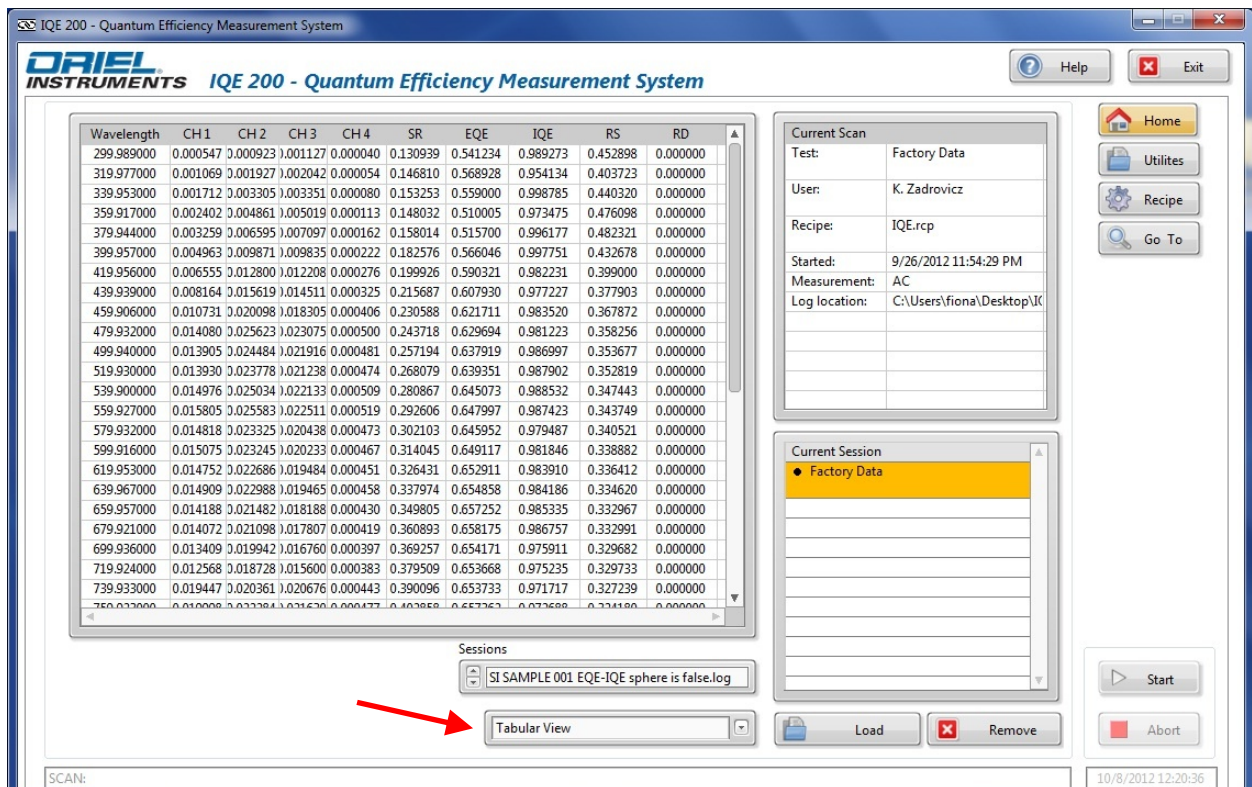

**Figure 48: Saved Scan, Tabular View**

The graphs may be viewed in Windows Notepad or exported to a spreadsheet application, such as Microsoft Excel, to perform data analysis.

```

SI SAMPLE 001 EQE-IQE sphere is false.log - Notepad
File Edit Format View Help
User: K. Zadrovicz
Test Name: Factory Data
Notes: Set sphere to false in config.ini. Run scan to verify performance of system.
Time: 9/26/2012 11:54:29 PM
Recipe: C:\Program Files\IQE200\recipes\IQE.rcp
X coordinate: 0.000000
Y coordinate: 0.000000
Scan type : EQE

wavelength  CH1      CH2      CH3      CH4      SR      EQE      IQE      RS      RD
299.989000  0.000547  0.000923  0.001127  0.000040  0.130939  0.541234  0.989273  0.452898  0.000000
319.977000  0.001069  0.001927  0.002042  0.000054  0.146810  0.568928  0.954134  0.403723  0.000000
339.953000  0.001712  0.003305  0.003351  0.000080  0.153253  0.590000  0.988785  0.440320  0.000000
359.917000  0.002402  0.004861  0.005019  0.000113  0.148032  0.510005  0.973475  0.476098  0.000000
379.944000  0.003259  0.006595  0.007097  0.000162  0.138014  0.515700  0.996177  0.482321  0.000000
399.957000  0.004963  0.009871  0.009835  0.000222  0.182576  0.566046  0.997751  0.432678  0.000000
419.956000  0.006555  0.012800  0.012208  0.000276  0.199926  0.590321  0.982231  0.399000  0.000000
439.959000  0.008164  0.015619  0.014511  0.000325  0.215687  0.607930  0.977227  0.377903  0.000000
459.906000  0.010731  0.020098  0.018305  0.000406  0.230588  0.621711  0.983500  0.367872  0.000000
479.932000  0.014080  0.025623  0.023075  0.000500  0.243718  0.629694  0.981223  0.358256  0.000000
499.940000  0.013905  0.024484  0.021916  0.000481  0.257194  0.637919  0.986997  0.353677  0.000000
519.930000  0.013930  0.023778  0.021238  0.000474  0.268079  0.639351  0.987902  0.352819  0.000000
539.900000  0.014976  0.025034  0.022133  0.000509  0.280867  0.645073  0.988532  0.347443  0.000000
559.927000  0.015805  0.025583  0.022511  0.000519  0.292606  0.647997  0.987423  0.343749  0.000000
579.932000  0.014818  0.023225  0.020438  0.000473  0.302103  0.645952  0.979487  0.340521  0.000000
599.916000  0.015075  0.023245  0.020233  0.000467  0.314045  0.649117  0.981846  0.338882  0.000000
619.933000  0.014752  0.022686  0.019484  0.000451  0.326431  0.652911  0.983910  0.336412  0.000000
639.967000  0.014909  0.022988  0.019465  0.000458  0.337974  0.654858  0.984186  0.334620  0.000000
659.957000  0.014188  0.021482  0.018188  0.000430  0.349805  0.657252  0.985335  0.332967  0.000000
679.921000  0.014072  0.021098  0.017807  0.000419  0.360893  0.658175  0.986757  0.332991  0.000000
699.936000  0.013409  0.019942  0.016760  0.000397  0.369257  0.654171  0.975911  0.329682  0.000000
719.924000  0.012568  0.018728  0.015600  0.000383  0.379509  0.653668  0.975235  0.329733  0.000000
739.933000  0.019447  0.020361  0.020676  0.000443  0.390096  0.653733  0.971717  0.327239  0.000000
759.923000  0.019998  0.022284  0.021630  0.000477  0.402858  0.657362  0.972688  0.324180  0.000000
779.960000  0.019318  0.022656  0.021389  0.000490  0.413409  0.657249  0.975918  0.326533  0.000000
799.966000  0.022420  0.027078  0.024885  0.000594  0.426002  0.660332  0.976928  0.324074  0.000000
819.942000  0.031503  0.038670  0.034863  0.000866  0.436174  0.659827  0.972482  0.321707  0.000000
839.960000  0.058853  0.073342  0.066080  0.001466  0.446848  0.659664  0.979203  0.326325  0.000000
    
```

Figure 49: Data Viewed in Notepad

### 10.3 GRAPH CONTROLS

The figure below illustrates the graph controls featured in the IQE200 software. When clicked, the magnifying glass icon gives the user a number of options to adjust the zoom. Six icons will be displayed and can be selected in the zoom control group.

The hand icon gives the user the option to pan around different areas of the graph.

Other icons include locking the X and Y scale and adjusting the precision of the units displayed in the X and Y axes.

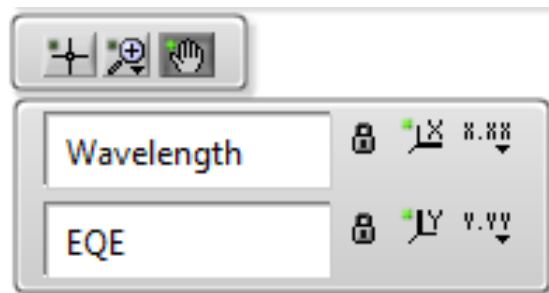

Figure 50: Graph Controls

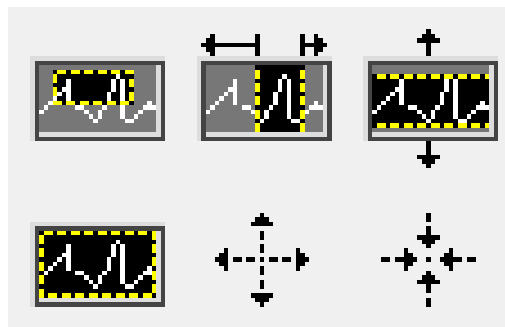

Figure 51: Zoom Control Group

•Zoom to Rectangle—With this option, click a point on the display you want to be the corner of the zoom area and drag the tool until the rectangle covers the zoom area.



Figure 52: Zoom to Rectangle

- X-zoom—Use this option to zoom in on an area of the graph along the x-axis.

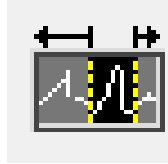

Figure 53: X-Zoom

- Y-zoom—Use this option to zoom in on an area of the graph along the y-axis.

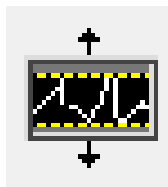

Figure 54: Y-Zoom

- Zoom In about Point—With this option, click a point you want to zoom in on. Press and hold the <Shift> key to switch between Zoom In about Point and Zoom Out about Point.

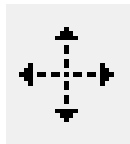

Figure 55: Zoom In about Point

- Zoom Out about Point—With this option, click a point you want to zoom out from.

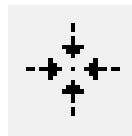

Figure 56: Zoom Out about Point

- Zoom to Fit—Use this option to autoscale all x- and y-scales on the graph or chart.

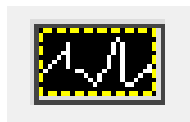

Figure 57: Zoom to Fit

## 10.4 METHODS

Click on the Methods button to access the area of the program where one may create, edit and save the parameters used when taking a scan of a sample.

To create a new method, click the New button. One may select a new method based on AC or DC templates. By default, it will be named "New Method". Click on the name to highlight it and change it.

Existing methods which have been saved in the default program folder will be listed. If methods have been saved in other locations, one can click on the folder to the right of the default path and select the other location.

By clicking on one of the methods listed, its parameters are listed and may be edited. Highlight the parameter to be changed. Values such as scan type can be selected from a pull-down list from the parameters value field. Then click Add/Update to update the field to the new selection.

For other values with a variety of user choices, such as starting wavelength, click Edit Selected button. Then type in the desired parameter value and click Add/Update.

The Add New Section button will add a group of parameters made up of the starting and ending wavelengths, as well as the step size. This will allow a user to run a scan with varying step sizes in order to focus on a region of interest. The order in which the sections are run by the software may be changed by highlighting a field and moving it up or down using the icons. To remove a section, click on the field to delete to highlight it. Then click on the Remove Selected Line button.

To use an existing method as a template for a new method, click on the name of the method and type in the new name. Then click Save. Both the new and existing methods will then be listed. Click on the new method and edit its parameters as needed.

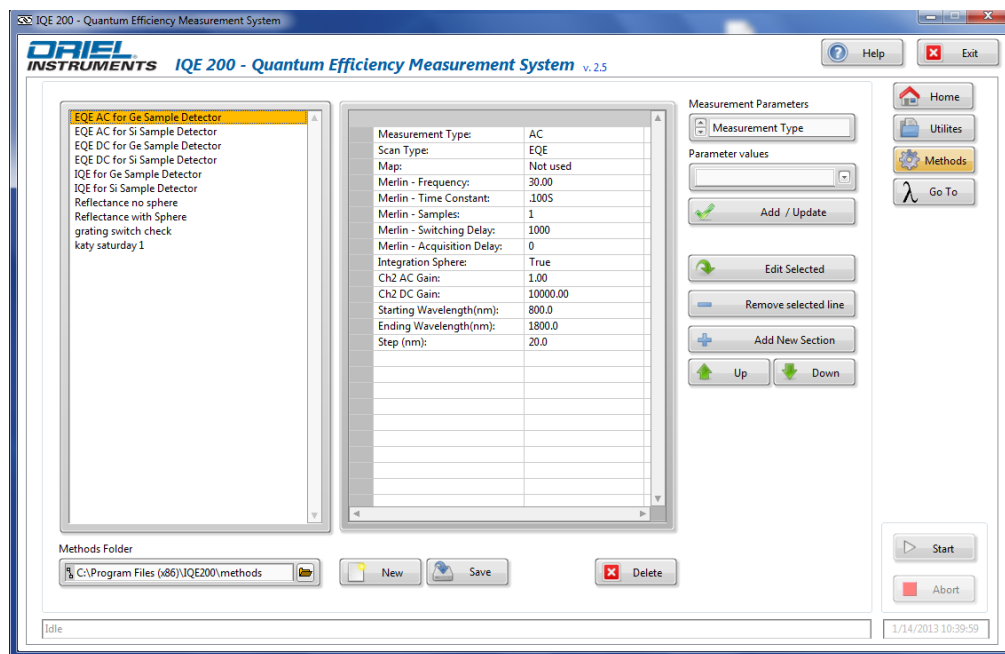
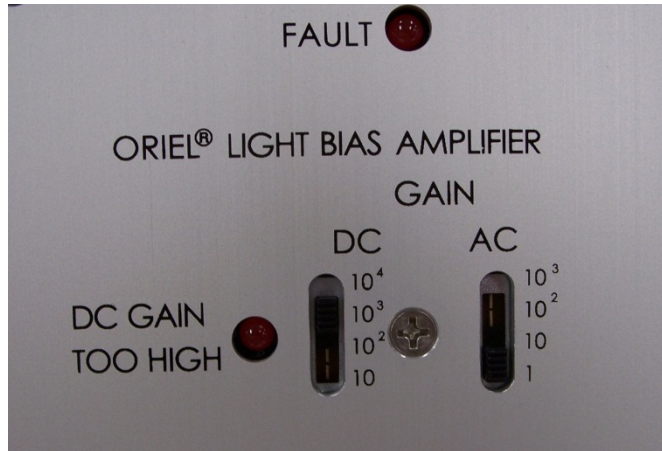

Figure 58: Methods Screen

The light bias amplifier (model 70714) is located in one of the equipment drawers of the IQE system. Sometimes it is necessary to change the gain on the test sample signal. Separate switches are located on top of the light bias amplifier for AC gain and DC gain. Refer to Figure 40.

When adjusting the gain switches, the Method parameters also must be updated to match.

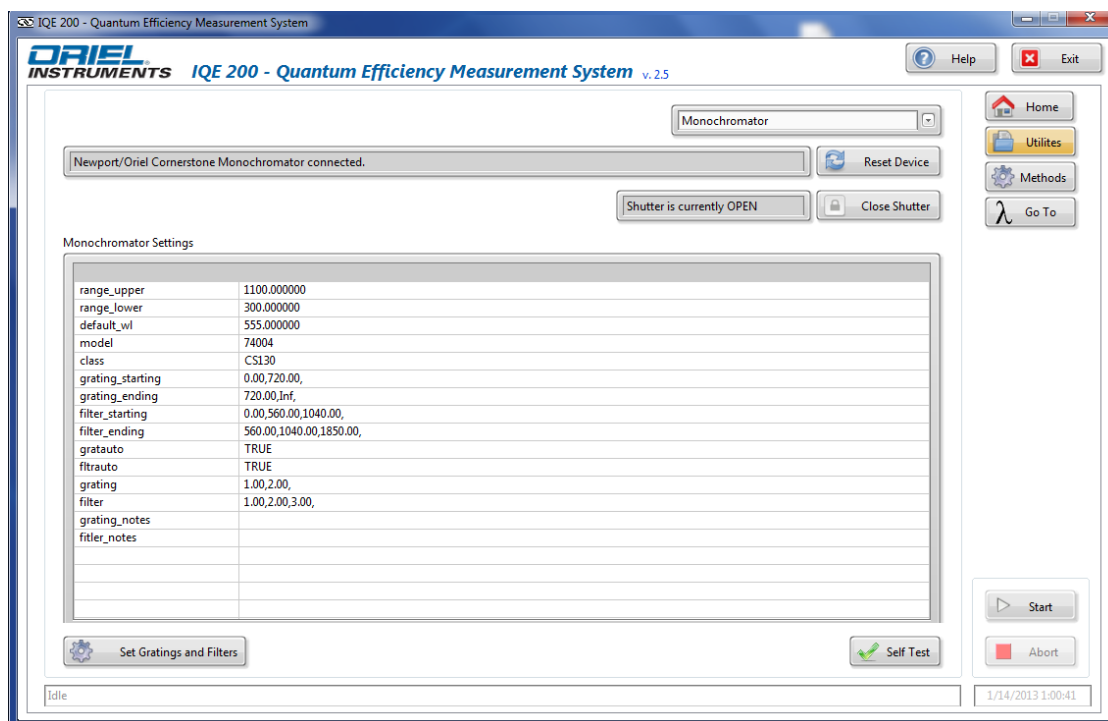

**Figure 59: Gain Settings**

## 10.5 INSTRUMENT UTILITIES

In the Utilities screen, operating parameters of the instruments that make up the IQE system may be accessed from a pull-down menu. Real-time performance can be assessed, and diagnostics can be run through the Self-Test icon. If an instrument does not pass the self-test, check power and USB cables. Then check the Windows device manager to find out if the instrument is being detected by the computer.

In the Home screen of the IQE software, click the Utilities icon. The initial view after the software has been started will display the monochromator settings. These are system settings that cannot be changed. Viewing them is only necessary for troubleshooting purposes.



**Figure 60: Monochromator Utility**

The Set Gratings and Filters button is password protected. The only time that these settings would need to be changed is during troubleshooting, with the guidance of the Oriel Instruments service department.

The Merlin™ lock-in amplifier may be selected from the pull-down menu. These parameters may be changed in real-time to view the resulting signal amplitude. However, these settings would not be applied to the next scan that would be run. Any time that a scan is run, the Merlin™ settings are governed by the parameters set up in the Method.

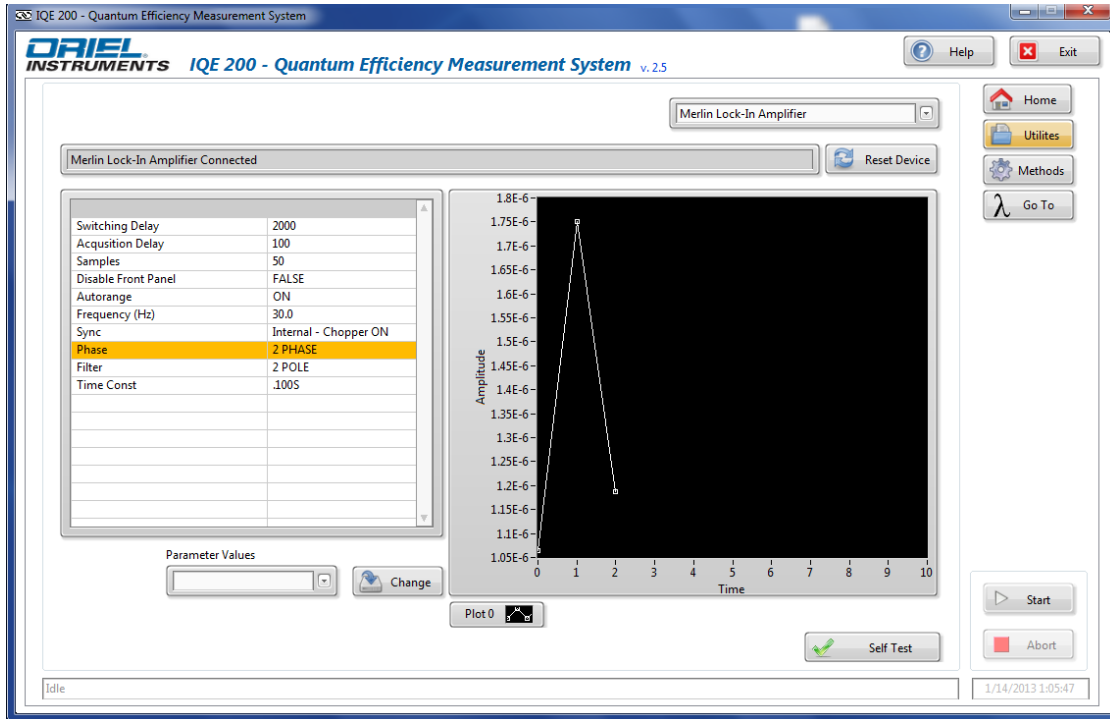

Figure 61: Merlin™ Utility

From the pull-down menu, the multiplexer settings may be accessed. The Port 0 Channel Control is for the manufacturer's use only and will never be utilized during normal operation (it is password protected).

The Port 1 Channel Control allows the user to display one or more voltages from the detectors.

- Channel 1 = Reference Detector
- Channel 2 = Sample
- Channel 3 = Rs Detector
- Channel 4 = Rd Detector (optional)

Voltages are displayed in a table, as well as in a graphical representation.

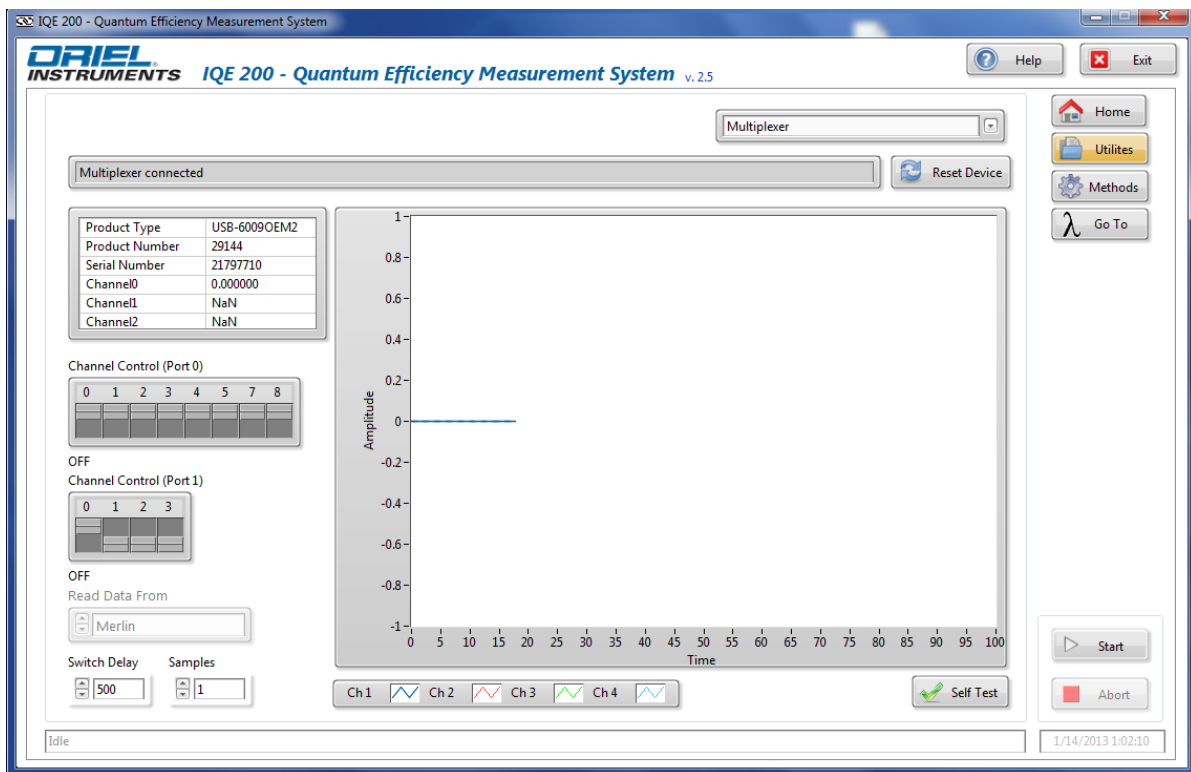

**Figure 62: Multiplexer Utility**

To ensure that a sample has been connected properly, select Channel 2. The data displayed is what is being read from the Merlin™ lock-in amplifier. The front display of the Merlin™ will show the same voltage as the multiplexer utility.

## 10.6 JSC CALCULATIONS

Jsc can be automatically calculated by the software for any saved log file with EQE data. The software will calculate Jsc for all of the following solar spectrums:

- AM0 (E490)
- AM0 (Wehrli)
- AM0 (ASTM)
- AM1.5G
- AM1.5D+C

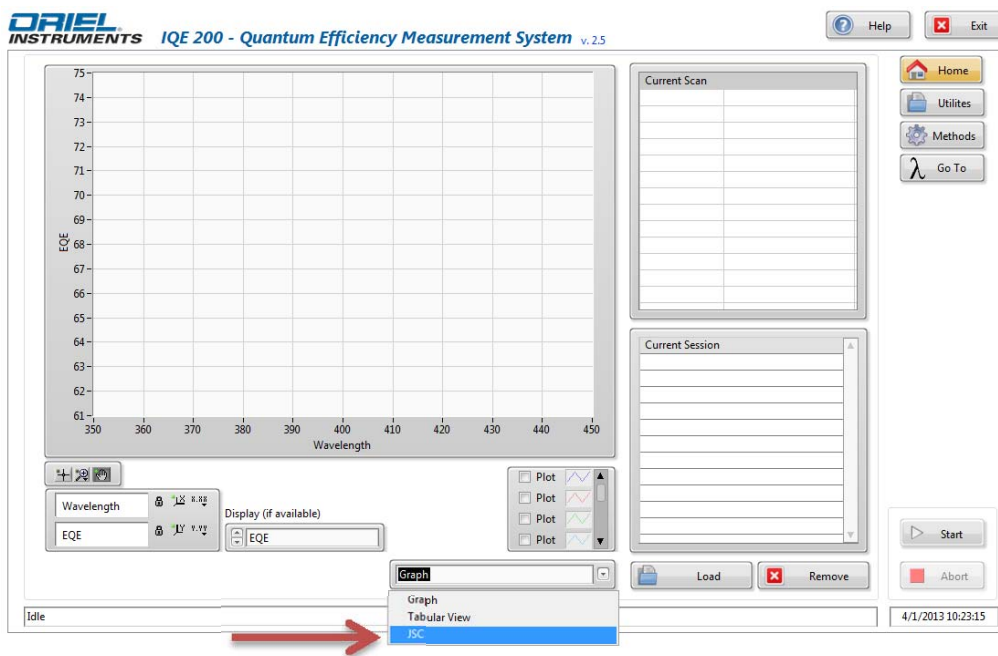

**Figure 63: Select Jsc**

To choose the log file to be loaded, click on the folder shown in the figure below. Navigate to the folder containing the file and select it.

No further action is needed. The software will return to the Jsc screen and display the information for all solar spectrums.

**Loaded File**

Wavelength	CH 1	CH 2	CH 3	CH 4	SR	EQE	IQE	RS	RD
499.999000	0.019322	0.036020	NaN	NaN	0.067111	0.166436	NaN	NaN	NaN
510.000000	0.019096	0.036232	NaN	NaN	0.068305	0.166075	NaN	NaN	NaN
519.997000	0.019044	0.037182	NaN	NaN	0.072240	0.172265	NaN	NaN	NaN
529.988000	0.019076	0.038342	NaN	NaN	0.076378	0.178701	NaN	NaN	NaN
539.975000	0.019166	0.039752	NaN	NaN	0.082964	0.190518	NaN	NaN	NaN
550.033000	0.019328	0.040758	NaN	NaN	0.086459	0.194914	NaN	NaN	NaN
560.010000	0.018244	0.039656	NaN	NaN	0.084772	0.187707	NaN	NaN	NaN
569.981000	0.017986	0.040078	NaN	NaN	0.089132	0.193907	NaN	NaN	NaN
580.024000	0.017970	0.040856	NaN	NaN	0.093216	0.199282	NaN	NaN	NaN
589.984000	0.017764	0.041060	NaN	NaN	0.094768	0.199179	NaN	NaN	NaN
600.015000	0.016884	0.039732	NaN	NaN	0.094129	0.194529	NaN	NaN	NaN
609.965000	0.016118	0.038412	NaN	NaN	0.090561	0.184101	NaN	NaN	NaN
619.985000	0.015920	0.038360	NaN	NaN	0.091563	0.183130	NaN	NaN	NaN
629.999000	0.015682	0.039292	NaN	NaN	0.097716	0.192331	NaN	NaN	NaN
640.007000	0.014906	0.038568	NaN	NaN	0.100909	0.195509	NaN	NaN	NaN
650.009000	0.015030	0.039998	NaN	NaN	0.106448	0.203068	NaN	NaN	NaN
660.005000	0.014368	0.038740	NaN	NaN	0.105155	0.197562	NaN	NaN	NaN

Integrated Jsc (mA/cm<sup>2</sup>)

AM0 (E490)  AM0 (Wehrii)  AM0 (ASTM)  AM1.5G  AM1.5D+C

Select Log File

Buttons: Load, Remove, Abort

Status: Idle | 4/1/2013 10:24:12

**Figure 64: Jsc Calculation Results**

## 11 CALIBRATION

### 11.1 DETERMINE IF RECALIBRATION IS NECESSARY

Three independent calibration routines are required for the Intelligent Quantum Efficiency System. All calibrations have been completed prior to shipment of the system. A recalibration of the EQE, Rs or Rd should only be performed when necessary.

Conduct a system verification to determine if a recalibration is required. If the data obtained matched that of the final data within the operating tolerances of the system, no recalibration is required.

### 11.2 CALIBRATION DATA

IQE200 system calibration files are stored on the computer at:  
C:\Program Files\Newport\IQE 200\configuration

The files for the required standards are stored at:  
C:\Program Files\Newport\IQE 200\configuration\Calibration Standards

File Name	Description	Required Standards
ch1.cal	EQE calibration	Calibrated detectors IQE-SAMPLE-SI (and IQE-SAMPLE-GE for extended range)
ch3.cal	Rs calibration	Low and high specular reflectance standards
ch4.cal	Rd calibration	Low and high diffuse reflectance standards (if an integrating sphere is used)

Note that if any of these standards are misplaced, a replacement can be ordered. The user would need to replace the file on the computer in the location shown in Figure 65. Note that verification scans using a new detector or high reflectance mirror would not match the factory supplied data file.

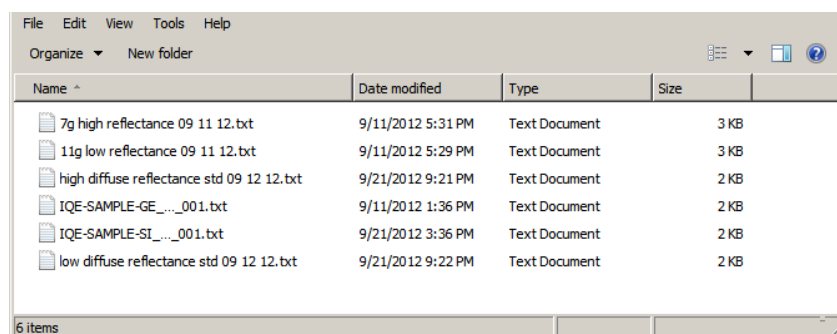

**Figure 65: Files for Calibration Standards**

### 11.3 HISTORICAL CALIBRATION FILES

A folder contains the files from previous calibrations. It is located at:  
C:\Program Files\IQE200\configuration\historical.

When any recalibration is performed, the previous calibration file is renamed YYMMDDhhmmss\_ch#.cal and saved to this sub-folder. The naming format is Year-Month-Day-hour-minute-second.

To revert back to a previous calibration file, rename the historical calibration as the file name shown in the table above. Move it into the configuration folder, replacing the newer calibration file.

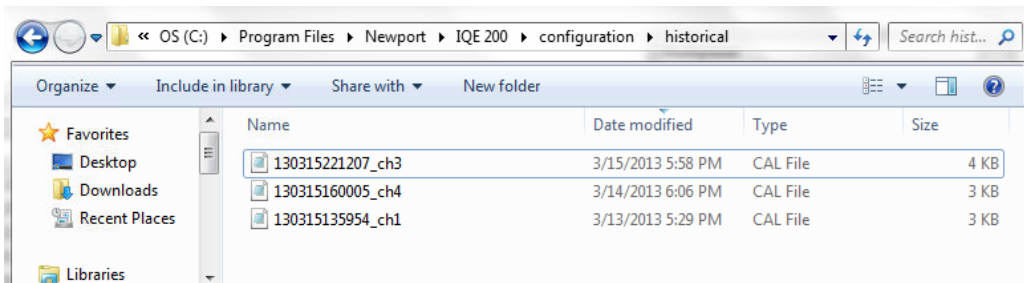
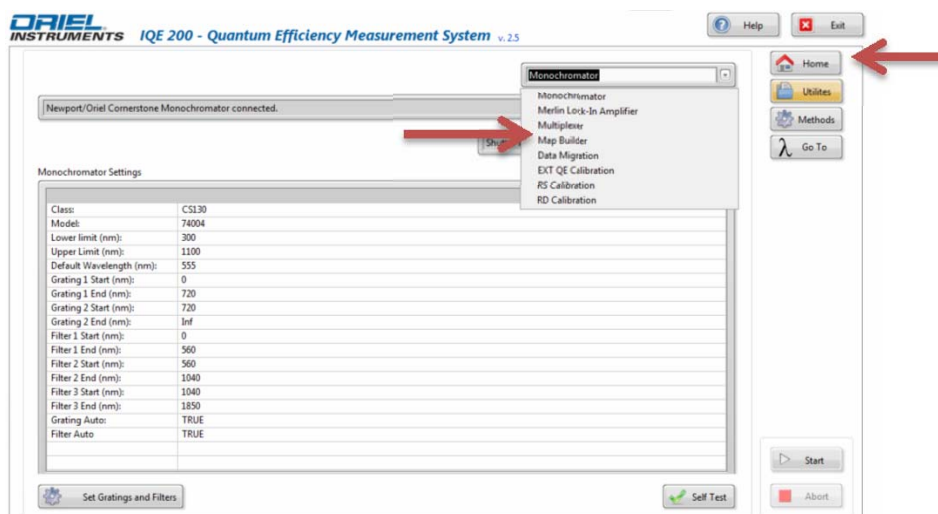

**Figure 66: Historical Calibration Data**

## 11.4 EXTERNAL QUANTUM EFFICIENCY (EQE) CALIBRATION

To begin the calibration process, click on the Utilities icon. Select “EXT QE Calibration” from the pull-down menu. Instructions will be provided at each step of the calibration process, as noted here.

A calibration wizard will guide the user through all the steps necessary to complete the calibration.



**Figure 67: Selecting the EQE Calibration Routine**

### **Step 1:**

“This process will calibrate the system for EQE measurement. You will need the standard detectors with known spectral responsivity in a txt file format.”

For systems that are designed for use up to 1100 nm, a silicon detector standard is required. For systems that extend to 1800 nm, both a silicon and a germanium detector standard are required. Refer to the system verification section of this manual for care and handling of the detector standards that were provided with the system.

These detectors have been calibrated so that their responsivities are known over the operating range of the system. The spectral responsivity of the detector(s) provided by Oriel Instruments have been saved on the computer in a tab delimited .txt file format.

Click the Next icon to proceed.

**Step 2:**

“Please position the standard Si detector at sample location. Load the Si detector responsivity file.”

Connect the BNC cable found in the test compartment to the IQE-SAMPLE-SI detector.

Place the detector onto the sample platform.

Adjust the platform height so that the light is focused on the detector. Refer to section in this manual on proper placement of the detector. Ensure that the light is hitting the detector element.

If an integrating sphere is provided with the system, place the detector flush under the integrating sphere. Use the light bias fiber holder opening to view the detector to ensure that the light is hitting the detector element.

Click the folder icon. Navigate to the responsivity file for the Si detector and select it.

It's default location is:

C:\Program Files\Newport\IQE 200\configuration\Calibration Standards

The name of the file will be IQE-SAMPLE-SI...####.txt, where #### is the serial number.

Click the Accept button.

The settings shown in the IQE200 software will be updated when the responsivity file is loaded. If one needs to select a different file, click the Change icon.

Click Next to proceed with the calibration process. The software will now take readings over the wavelength range of this detector.

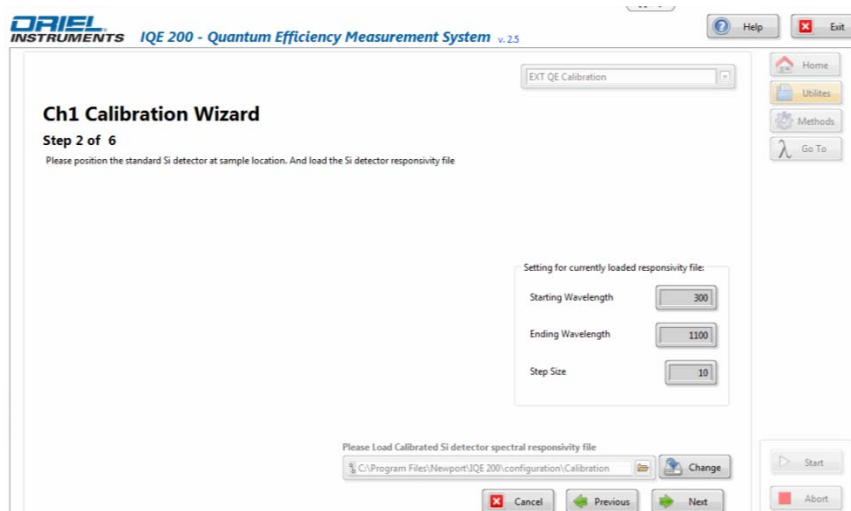

**Figure 68: EQE Calibration, Step 2**

**Step 3:**

The software will automatically scan the detector over its operating wavelength in 10 nm increments.

**Step 4:**

***This step applies to extended range systems only. For standard range IQE systems, skip to Step 6.***

“Please position the standard Ge detector at sample location. Load the Ge detector responsivity file.”

Connect the BNC cable found in the test compartment to the IQE-SAMPLE-GE detector.

Place the detector onto the sample platform.

Adjust the platform height so that the light is focused on the detector. Refer to section in this manual on proper placement of the detector. Ensure that the light is hitting the detector element.

If an integrating sphere is provided with the system, place the detector flush under the integrating sphere. Use the light bias fiber holder opening to view the detector to ensure that the light is hitting the detector element.

Click the folder icon. Navigate to the responsivity file for the Ge detector and select it.

It's default location is:

C:\Program Files\Newport\IQE 200\configuration\Calibration Standards

The name of the file will be IQE-SAMPLE-GE...###.txt, where ### is the serial number.

Click the Accept button.

The settings shown in the IQE200 software will be updated when the responsivity file is loaded. If one needs to select a different file, click the Change icon.

Click Next to proceed with the calibration process. The software will now take readings over the wavelength range of this detector.

**Step 5:**

***This step applies to extended range systems only. For standard range IQE systems, skip to Step 6.***

The software will automatically scan the detector over its operating wavelength in 10 nm increments.

**Step 6:**

The results of the calibration process will be displayed in a graph. Click Accept if satisfied with the result.

When the user clicks the Save button, the system will store the calibration under the file name Ch1.cal.

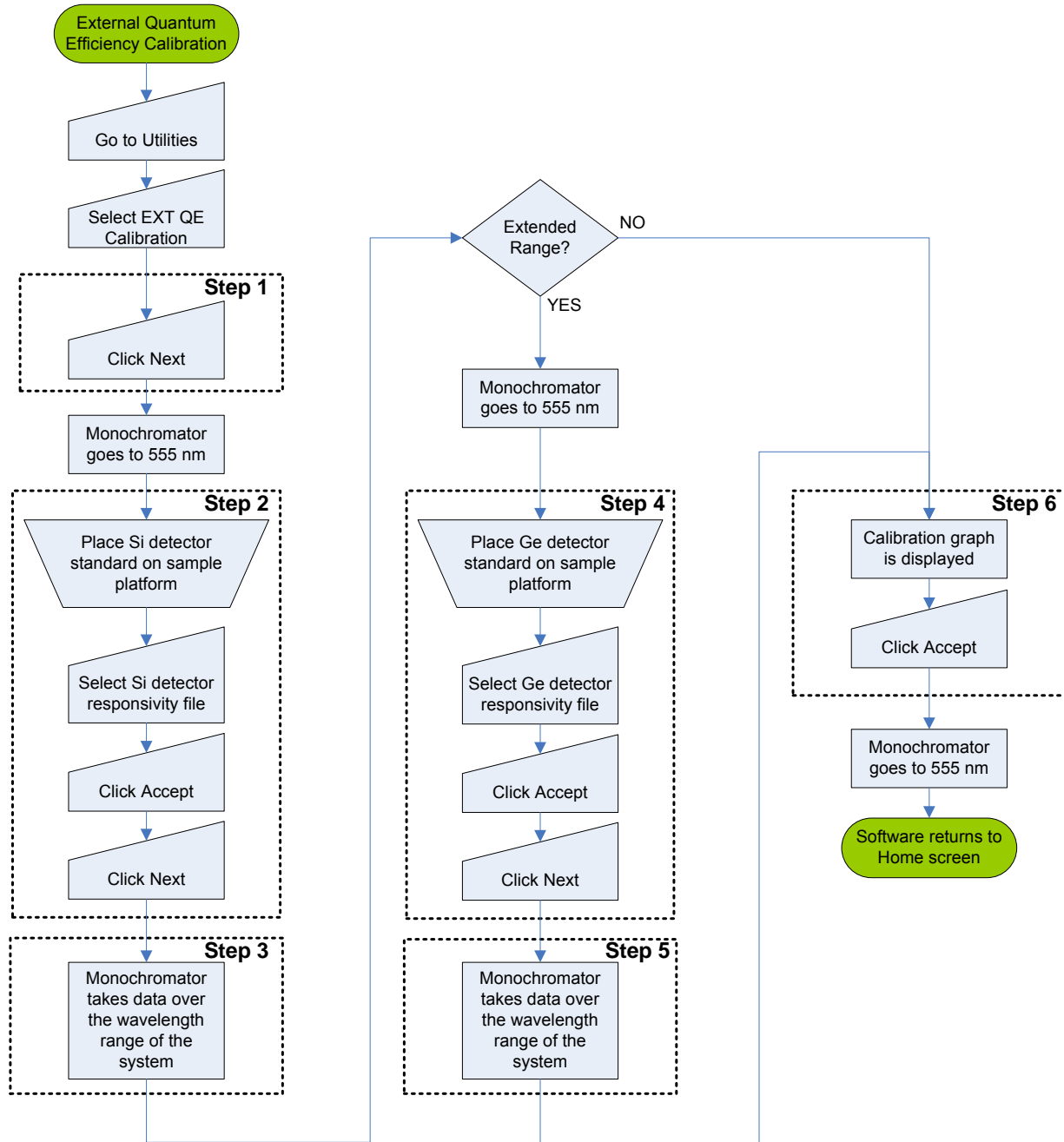
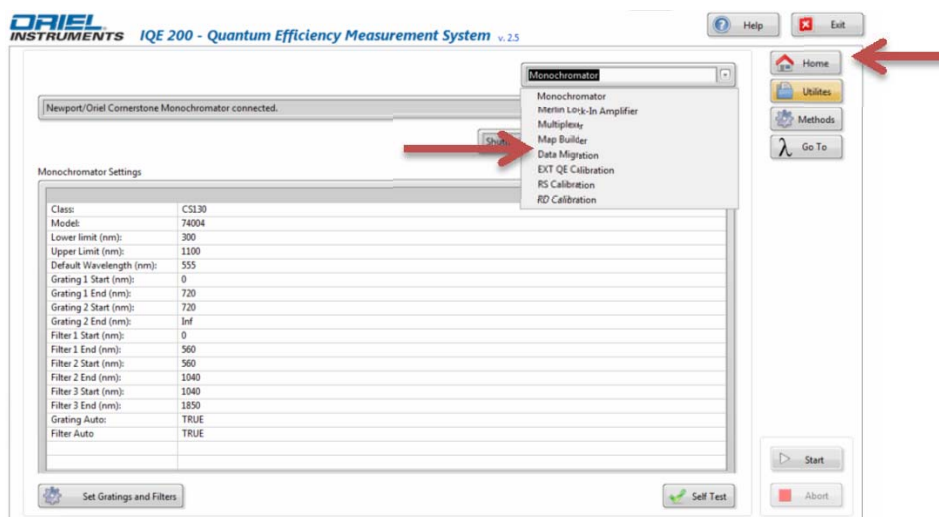

**Figure 69: EQE Calibration Process Flowchart**

## 11.5 SPECULAR REFLECTANCE (RS) CALIBRATION

To begin the calibration process, click on the Utilities icon. Select “RS Calibration” from the pull-down menu. Instructions will be provided at each step of the calibration process, as noted here.

A calibration wizard will guide the user through all the steps necessary to complete the calibration.



**Figure 70: Selecting the Specular Reflectance Calibration Routine**

### **Step 1:**

“This process will calibrate the system for Specular Reflectance. You will need the standard reflectance samples with known reflectance in a txt file format.”

To perform the Rs calibration, one needs to use the low and high specular reflectance standards that came with the system. The low specular reflectance standard is black glass. The high specular reflectance standard is a mirror.

The specular reflectance standards should not have fingerprints or other contaminants on their surfaces. Contamination or other damage to the standards may result in an inaccurate Rs calibration. If needed, wipe them clean with a clean, soft cloth and isopropyl alcohol. One may also use a bulb blower to remove any dust. Store them in their cases when not in use.

Click the Next icon to proceed.

**Step 2:**

“Please position the low reflectance standard (black glass) at sample location. Load the low reflectance standard file.”

Position the low specular reflectance standard (black glass) on the sample platform with the non-reflective piece of flocking underneath it to prevent unwanted reflections.

The black glass piece must be placed so that the model number printed on its edge is facing up.

The standard must sit flat. If the piece of flocking is not lying flat, it can be affixed to a solid block since it has an adhesive backing. Peel off the paper on the back side to apply. If the optional temperature controlled vacuum chuck has been purchased, one may apply vacuum to hold the flocking onto the plate. Do not apply the adhesive side to the vacuum chuck.

The standard must be placed so that the light is focused on the surface. One can judge that the light is focused when the spot is as small as possible with sharply defined edges.

If the integrating sphere is not in used, place a flat piece of paper on the surface of the reflectance standard (a business card is ideal since it does not bend easily). Then adjust the height of the sample platform until the green light is focused on the paper. Then remove the paper.

If an integrating sphere is used, place the standard flush against the underside and ensure that the entire opening is blocked by the standard.

{Note that since the low and high specular reflectance standards are of different thicknesses, the platform height will need to be adjusted when switching from one to the other.}

Load the low specular reflectance data file.

Click the folder icon. Navigate to the reflectance data file for the low specular reflectance standard and select it.

It's default location is:

C:\Program Files\Newport\IQE 200\configuration\Calibration Standards

The name of the file will be #g LOW REFLECTANCE mm dd yyyy, where # represents the number written on the plastic case and mm dd yy represents when the data was taken.

Click the Accept button.

The settings shown in the IQE200 software will be updated when the reflectance file is loaded. If one needs to select a different file, click the Change icon.

Click Next to proceed with the calibration process.

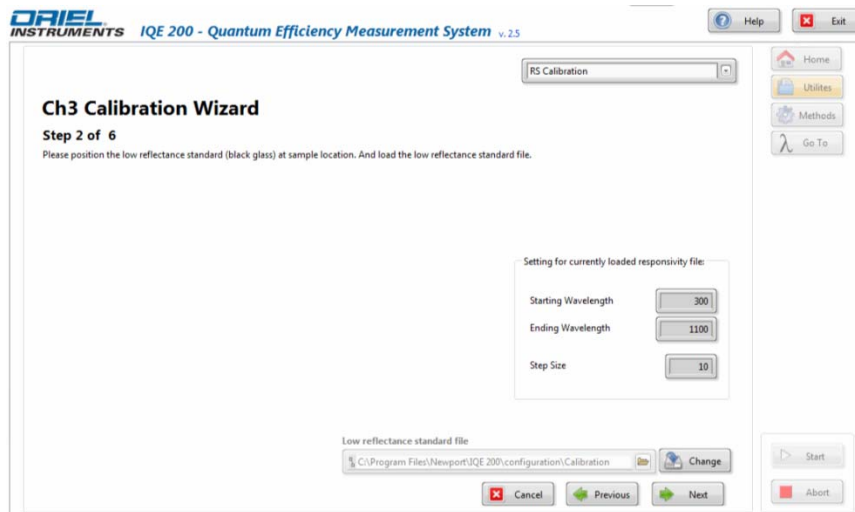

Figure 71: RS Calibration, Step 2



Figure 72: Low Specular Reflectance Standard During Calibration

**Step 3:**

The software will take readings over the wavelength range of the system.

**Step 4:**

“Please position the high reflectance standard (mirror) at sample location. Load the high reflectance standard file.”

Position the high specular reflectance standard (mirror) on the sample platform.

The standard must be placed so that the light is focused on the surface. One can judge that the light is focused when the spot is as small as possible with sharply defined edges.

If the integrating sphere is not in used, place a flat piece of paper on the surface of the reflectance standard. (a business card is ideal since it does not bend easily). Then adjust the height of the sample platform until the green light is focused on the paper. Then remove the paper.

If an integrating sphere is used, place the standard flush against the underside and ensure that the entire opening is blocked by the standard.

{Note that since the low and high specular reflectance standards are of different thicknesses, the platform height must be adjusted when switching from one to the other.}

Load the high specular reflectance data file.

Click the folder icon. Navigate to the reflectance data file for the high specular reflectance standard and select it.

It's default location is:

C:\Program Files\Newport\IQE 200\configuration\Calibration Standards

The name of the file will be #g HIGH REFLECTANCE mm dd yyyy, where # represents the number written on the plastic case and mm dd yy represents when the data was taken.

Click the Accept button.

The settings shown in the IQE200 software will be updated when the reflectance file is loaded. If one needs to select a different file, click the Change icon.

Click Next to proceed with the calibration process.

High Specular  
Reflectance  
Standard  
(mirror)

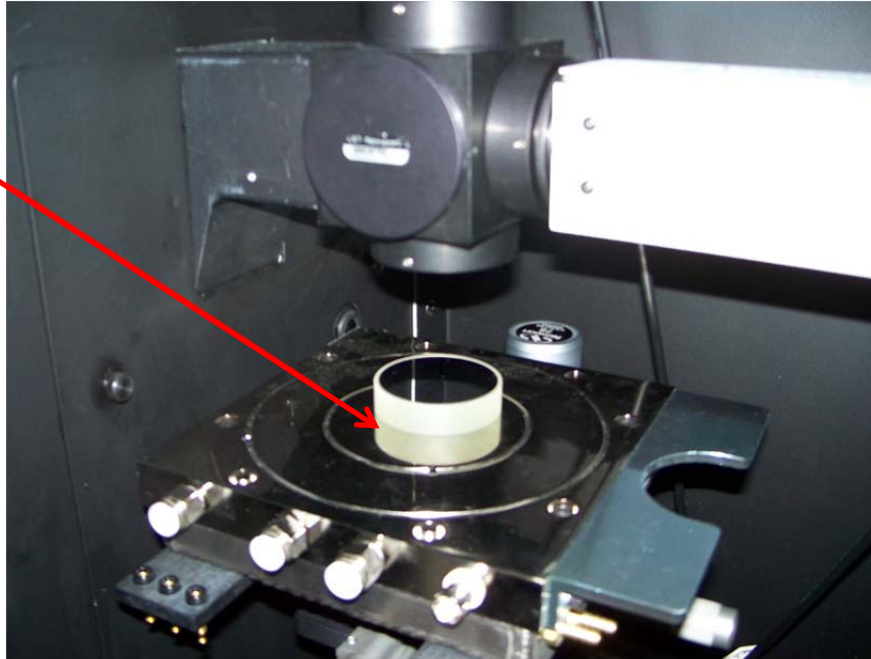

**Figure 73: High Specular Reflectance Standard During Calibration**

**Step 5:**

The software will take readings over the wavelength range of the system.

**Step 6:**

“Review the calibration factors. When satisfied, click the Save button.”

The calibration process is complete. The graph indicates the calibration factors that have been obtained. If satisfied, click the Save button. If the graph does not appear normal, check the calibration process for any errors.

When the user hits the Save button, the system will store the calibration under the file name Ch3.cal.

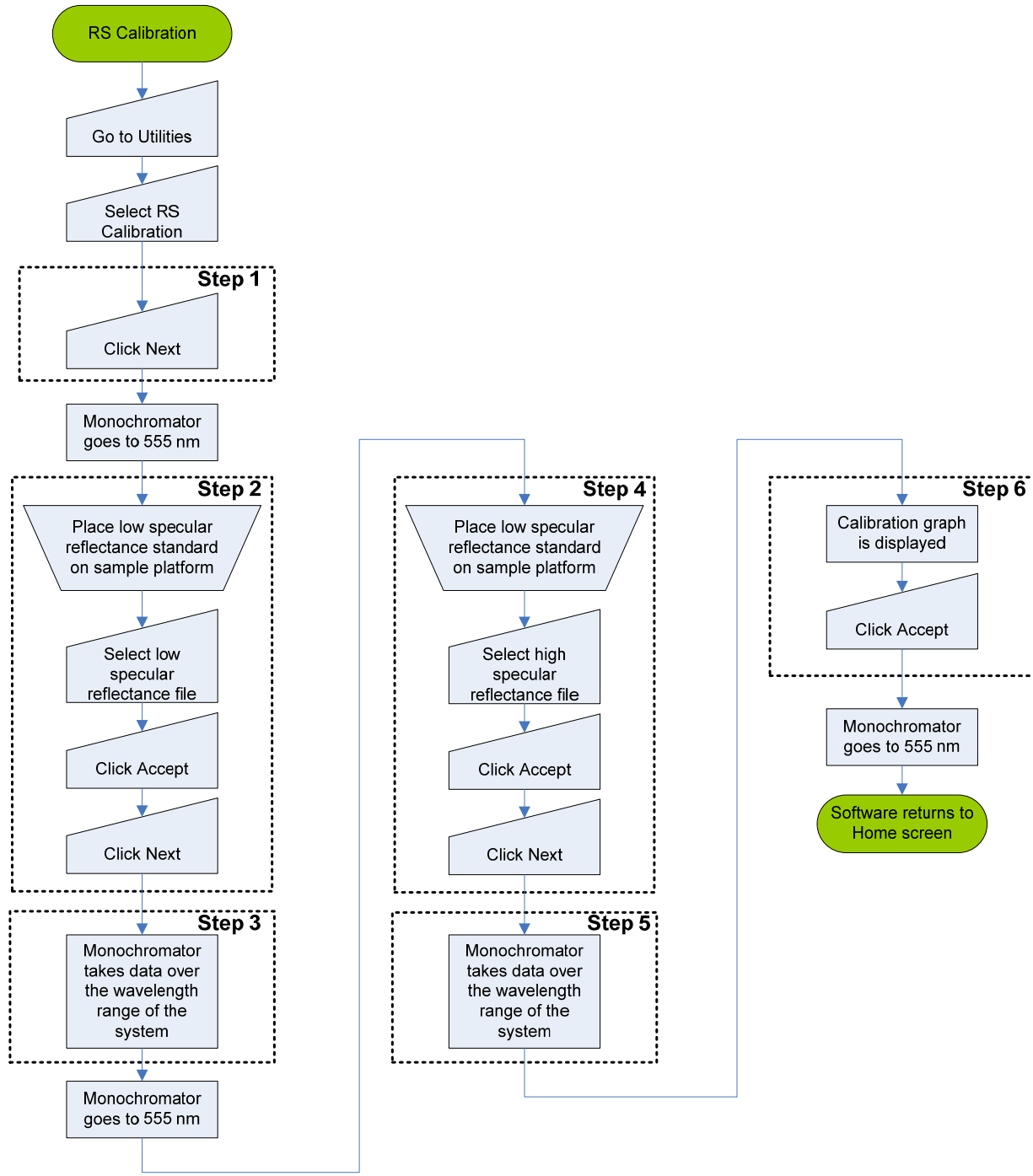

**Figure 74: RS Calibration Process Flowchart**

## 11.6 DIFFUSE REFLECTANCE (RD) CALIBRATION

To begin the calibration process, click on the Utilities icon. Select “RD Calibration” from the pull-down menu. Instructions will be provided at each step of the calibration process, as noted here.

This calibration file is required only with systems that are equipped with the optional integrating sphere. The integrating sphere must be fixed in place on the system when performing this calibration routine.

A calibration wizard will guide the user through all the steps necessary to complete the calibration.

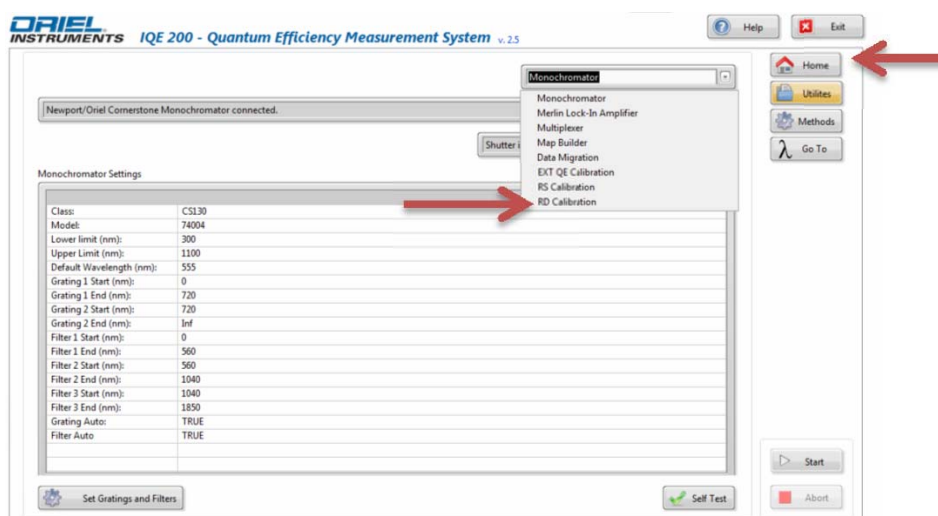

**Figure 75: Selecting the Diffuse Reflectance Calibration Routine**

### **Step 1:**

“This process will calibrate the system for Diffusive Reflectance. You will need the standard diffusive reflectance samples with known reflectance in a txt file format.”

To perform the Rd calibration, one needs to use the low and high diffuse reflectance standards that came with the system. The low diffuse reflectance standard is black. The high diffuse reflectance standard is white.

The diffuse reflectance standards should not have fingerprints or other contaminants on their surfaces. Contamination or other damage to the standards may result in an inaccurate Rs calibration. Handle them carefully and do not touch their surfaces, as they are difficult or impossible to clean. Store them with their covers in place when not in use.

Click the Next icon to proceed.

**Step 2:**

“Please position the low diffusive reflectance standard at sample location. And load the low diffusive reflectance standard file.”

Position the low diffuse reflectance standard (black piece) on the sample platform.

The standard must be placed so that the light is focused on the surface. One can judge that the light is focused when the spot is as small as possible with sharply defined edges.

If the integrating sphere is not in used, place a flat piece of paper on the surface of the reflectance standard. (a business card is ideal since it does not bend easily). Then adjust the height of the sample platform until the green light is focused on the paper. Then remove the paper.

If an integrating sphere is used, place the standard flush against the underside and ensure that the entire opening is blocked by the standard.

Load the low diffuse reflectance data file.

Click the folder icon. Navigate to the reflectance data file for the low diffuse reflectance standard and select it.

It's default location is:

C:\Program Files\Newport\IQE 200\configuration\Calibration Standards

The name of the file will be LOW DIFFUSE REFLECTANCE mm dd yyyy, where mm dd yyyy represents when the data was taken.

Click the Accept button.

The settings shown in the IQE200 software will be updated when the reflectance file is loaded. If one needs to select a different file, click the Change icon.

Click Next to proceed with the calibration process.

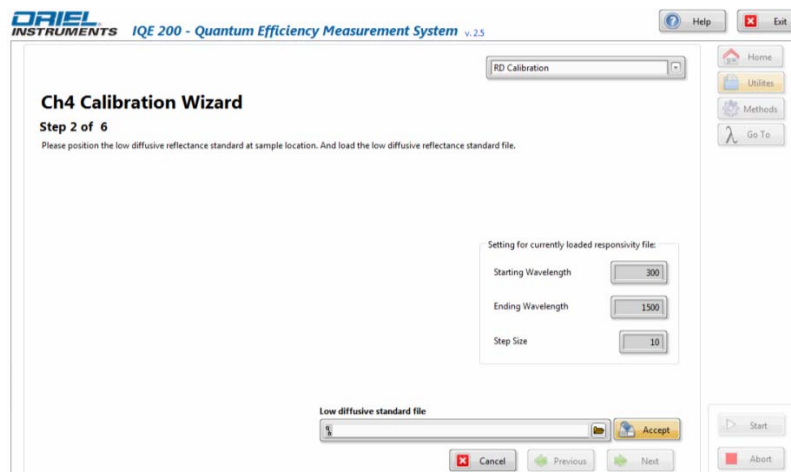

**Figure 76: RS Calibration, Step 2**

**Step 3:**

The software will take readings over the wavelength range of the system.

**Step 4:**

“Please position the high diffusive reflectance standard at sample location. And load the high diffusive reflectance standard file.”

Position the high diffuse reflectance standard (white piece) on the sample platform.

The standard must be placed so that the light is focused on the surface. One can judge that the light is focused when the spot is as small as possible with sharply defined edges.

If the integrating sphere is not in used, place a flat piece of paper on the surface of the reflectance standard. (a business card is ideal since it does not bend easily). Then adjust the height of the sample platform until the green light is focused on the paper. Then remove the paper.

If an integrating sphere is used, place the standard flush against the underside and ensure that the entire opening is blocked by the standard.

Load the high diffuse reflectance data file.

Click the folder icon. Navigate to the reflectance data file for the high diffuse reflectance standard and select it.

It's default location is:

C:\Program Files\Newport\IQE 200\configuration\Calibration Standards

The name of the file will be HIGH DIFFUSE REFLECTANCE mm dd yyyy, where mm dd yy represents when the data was taken.

Click the Accept button.

The settings shown in the IQE200 software will be updated when the reflectance file is loaded. If one needs to select a different file, click the Change icon.

Click Next to proceed with the calibration process.

**Step 5:**

The software will take readings over the wavelength range of the system.

**Step 6:**

“Review the calibration factors. When satisfied, click the Save button.”

The calibration process is complete. The graph indicates the calibration factors that have been obtained. If satisfied, click the Save button. If the graph does not appear normal, check the calibration process for any errors.

When the user clicks the Save button, the system will store the calibration under the file name Ch4.cal.

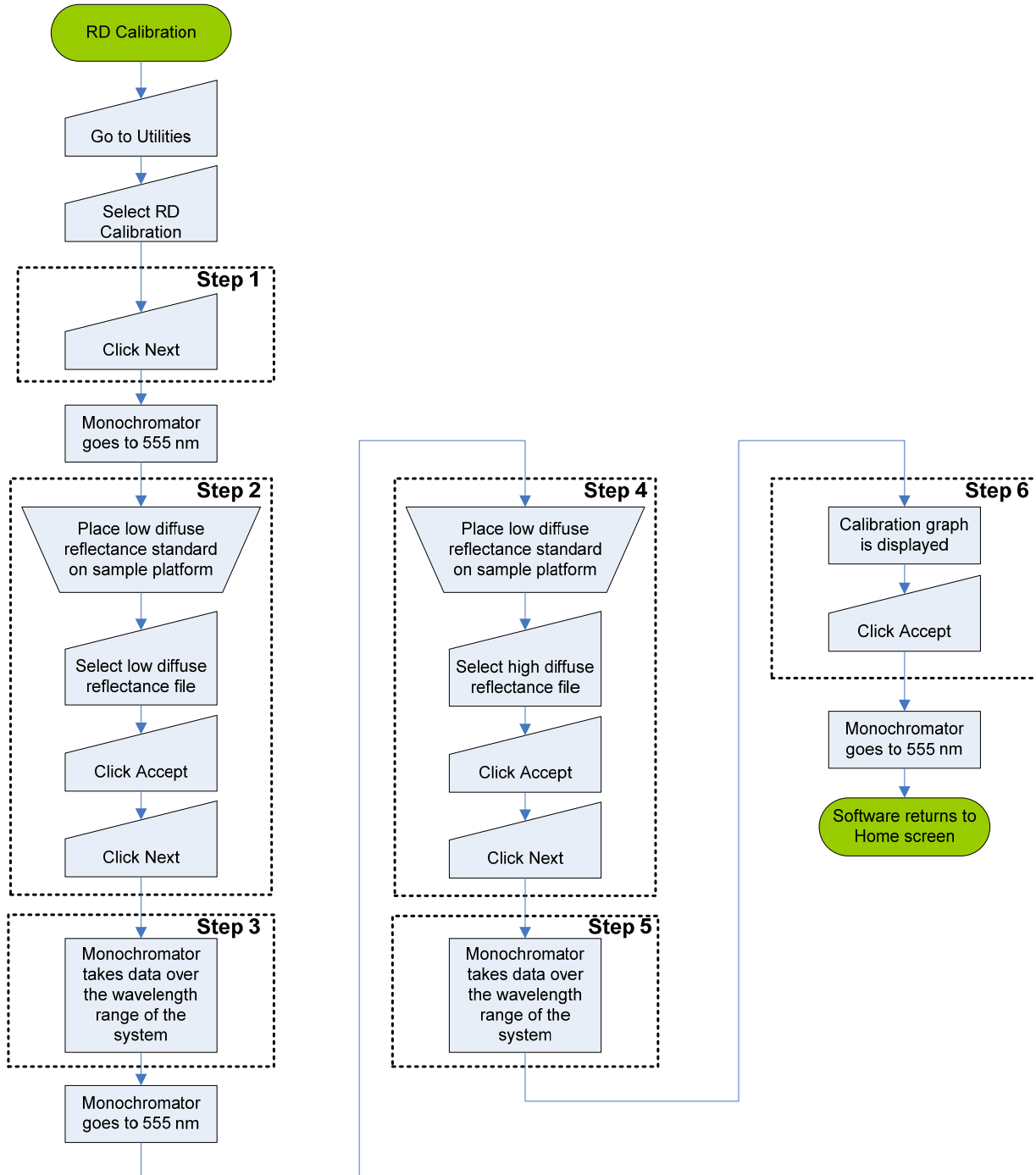

**Figure 77: RD Calibration Process Flowchart**

## 12 MAINTENANCE

---

### 12.1 LAMP REPLACEMENT

The *average* life of the standard arc lamp is 1000 hours. For the standard QTH lamp, the average life is 50 hours. Note that the lifetime of the lamp can be affected by the manner in which it is used. Frequent ignitions (for arc lamps), contamination of the lamp envelope and an excessively hot operating environment can all lead to reduced lamp life.

To avoid system down time, consider purchasing a replacement lamp as the lamp nears the end of its useful life.

250W QTH Lamp	Part Number 6334NS
150W Xe Lamp	Part Number 6255

The hours of use should be regularly monitored on the lamp's power supply, and reset when the lamp is replaced. To check the lamp hours on the power supply, press the Display/Select button until the Lamp Hours LED is illuminated.

Always wear powder-free gloves and eye protection when handling a lamp and read all precautions that came with the replacement lamp. The IQE system should be powered off. During lamp replacement, it is an ideal time to inspect the lamp housing for signs of wear. Refer to the next section for more information.

When an arc lamp is to be replaced, remove the old lamp and unscrew the brass socket adapter from the bottom terminal. On the replacement lamp, remove the thumb screw on the bottom terminal and screw on the brass socket adapter. Refer to the lamp installation section of this manual for more information.

To reset the lamp hours on the power supply, the lamp must be off and the power supply turned on.

Press the Setup button.

Press the Display/Select button until Hrs Reset LED is blinking.

Press and hold the Set/Enter button until the display goes blank.

Press Setup.

### 12.2 CLEANING

Clean the exterior of the system using a clean, dry cloth. Ensure that the ventilation holes are not blocked with dust. Vacuum the openings, if necessary.

When not in use, cover any openings on the integrating sphere.

### 12.3 ARC LAMP HOUSING INSPECTION

The material used inside an arc lamp housing is subjected to UV light. UV light will eventually cause degradation of materials. When the lamp housing door has been removed to replace the lamp, it is the ideal time to examine the lamp housing for signs of wear.

When the lamp is being replaced, one can examine the interior of the lamp housing to check for signs of wear.

The rear reflector should not be cleaned. It has a special coating on it that will be damaged when wiped down.

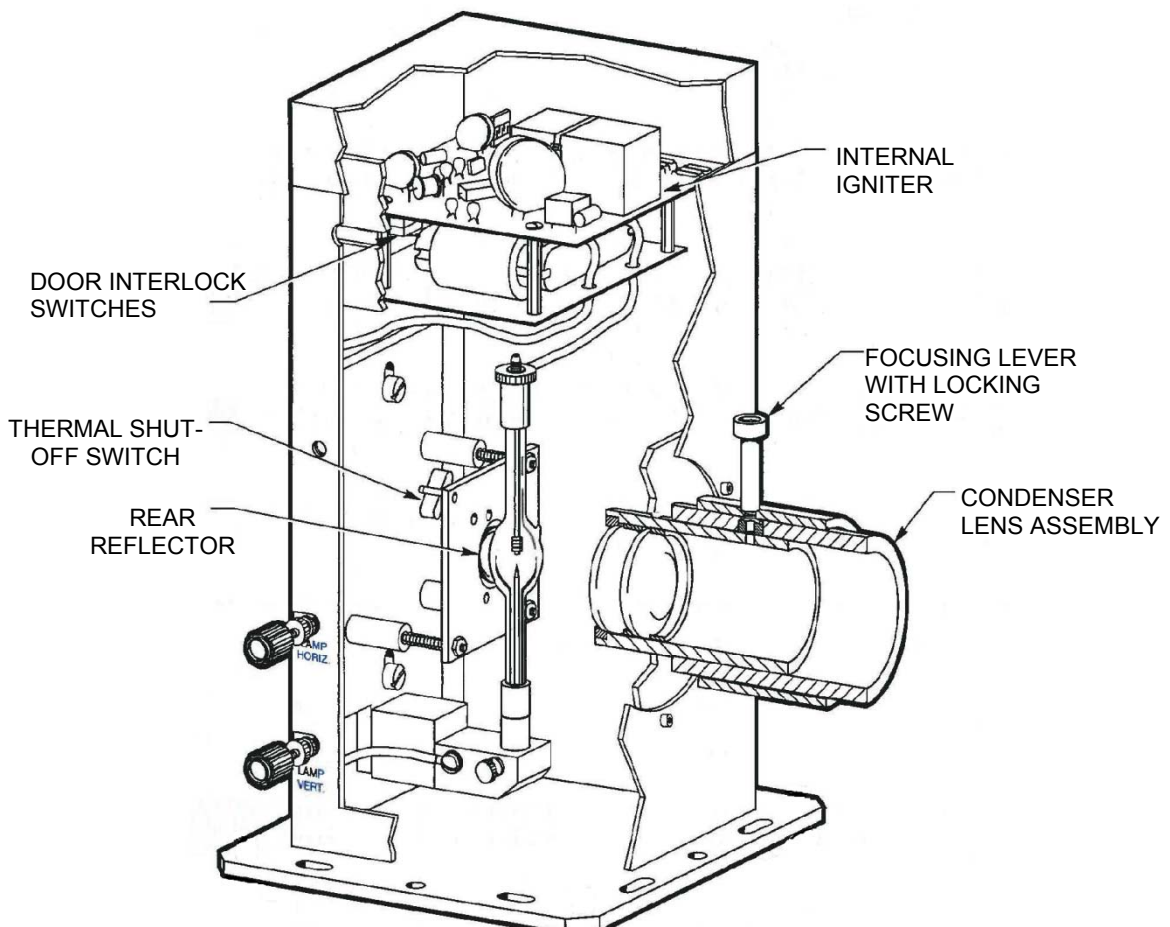

Figure 78: Arc Lamp Housing Construction

The underside of the lamp housing igniter can be seen when looking in the lamp compartment. Insulation tubing covers the thick white lamp cables. Cable ties hold the transformer assembly in place. All of these items can degrade with exposure to UV light.

The insulation tubing is normally clear and will maintain its integrity for a long time. As it is exposed to the light, it will gradually discolor. As it becomes a deep yellow-brown color, it will also become brittle. If the tubing splits, the next ignition attempt may fail. Arcing to the igniter circuit board may occur.

It is not recommended to remove and inspect the igniter. The insulation tubing and cable ties are visible during normal lamp replacement.

A worn or damaged igniter may be repaired or replaced. Contact Oriel Instruments or the representative through whom this equipment was purchased for servicing. A Repair Material Authorization (RMA) number is required before sending any item in for servicing.

## 12.4 QTH LAMP HOUSING INSPECTION

The material used inside an a QTH lamp housing is subjected to UV light. UV light will eventually cause degradation of materials. When the lamp housing door has been removed to replace the lamp, it is the ideal time to examine the lamp housing for signs of wear.

When the lamp is being replaced, one can examine the interior of the lamp housing to check for signs of wear.

The rear reflector should not be cleaned. It has a special coating on it that will be damaged when wiped down.

The socket adapter that the lamp plugs into will eventually become worn. Consider replacing this item periodically. The frequency at which a replacement should be installed will vary depending on the operator, environment and usage.

## 13 TROUBLESHOOTING

---

### 13.1 SYSTEM VERIFICATION ERROR

Possible reasons for the verification data to not match the new scans include a change in lamp position after shipment, contamination on the sample detector windows (reflectance readings are particularly sensitive to this), incorrect lamp optimization or an item becoming loose due to rough handling during shipment.

Potentially large measurement errors can be generated through scratches, digs and coating damage on detector optical surfaces. The magnitude of an error typically varies directly with the ratio of the intercepted area of the “scratch” relative to the area of the optical beam.

The photodiode sensitivity increases with temperature for wavelengths longer than the peak response wavelength. Best results will be obtained by keeping the detector near the calibration temperature of 25°C when operating the system.

During use or storage, the temperature range of 0°C to +40°C should not be exceeded. Also, the detector should not be exposed to humidity levels greater than 70% or possible damage to the photodiode could occur.

Drifts in temperature and ambient lighting can cause significant variations in diode response and amplifier performance for low power measurements. It is therefore important to provide as constant environmental conditions as practical, including consideration of air conditioning and room lighting effects.

The effect of room lighting is dependent upon the facility and types of cells being tested. Although leaving the sample compartment door closed for AC measurements is almost always not necessary, it can be helpful in eliminating possible sources of error. In addition, the noise and dark current generally increase exponentially with detector temperature, so it is best to keep the temperature close to 25°C.

Individual detector response can change with time at different wavelengths - especially in the ultraviolet - and should be returned for recalibration periodically to assure confidence in the accuracy of the measurement.

## 13.2 TEST SAMPLE SATURATION

For low optical power, the photocurrent is proportional to the optical signal incident on the photodiode and the photocurrent linearly increases with optical power. For high optical powers saturation of the detector begins to occur and the response signal is no longer linearly proportional to the incident power. Optical power measurements must be made in the linear region to be valid.

The saturation is “soft”, i.e. the detector output does not suddenly stop increasing, but the rate of increase slows. The onset of saturation is not always obvious and is a common source of inaccurate measurements.

Example:

A xenon lamp produces emission lines that are particularly strong between 850 nm and 1050 nm. If an EQE graph displays an unusual appearance in this area, it is possible that the cause is saturation of the sample. To verify if this is the problem, the monochromator output slit can be narrowed and the scan repeated.

## 13.3 POWER SUPPLY ERROR MESSAGES

The power supply will display an error messages to indicate various reasons as to why a lamp cannot be ignited. Only one message can be displayed at one time.

Message	Error	Possible Causes
iLOC	Interlock Error	<ul style="list-style-type: none"> <li>• Lamp housing door not closed.</li> <li>• Black lamp cable not in place.</li> <li>• Overheating</li> </ul>
LP	Lamp Housing or Lamp Failure	<ul style="list-style-type: none"> <li>• Lamp reached end of life.</li> <li>• Replacement lamp installed upside down.</li> <li>• Lamp construction defect.</li> <li>• Excessive humidity / condensation on igniter.</li> <li>• Igniter component failure.</li> <li>• Arcing due to insulation wear.</li> </ul>
PS	Power Supply Failure	<ul style="list-style-type: none"> <li>• Contact for service</li> </ul>

If an iLOC error is displayed, check that the door is secured in place. If necessary, loosen the door screws, push the door upward and re-tighten the screws. Ensure the black cable going to the left side of the lamp housing is secure. If all items are in place, contact for service.

There are no user serviceable parts inside of the power supply. Do not open and attempt to troubleshoot this unit. Contact Oriel Instruments or the representative from whom this system was purchased for service.

For more information on the LP error message, refer to the section in this manual on lamp ignition difficulties.

### **13.4 DIFFICULTY IGNITING ARC LAMP**

When the Lamp On button is pushed on the power supply, up to five ignition attempts are made. If the arc lamp does not ignite, an LP error will appear on the power supply display. Ignition failure can be due to a number of causes.

The system is designed to operate in a typical laboratory atmosphere. Excessive humidity or condensation on the igniter will cause an LP error. A clicking noise is heard when ignitions are attempted. If the clicking noise is absent, there may be a problem with a component on the igniter itself.

If a replacement lamp is installed upside down, it will likely ignite. However, the lifespan of the lamp is greatly reduced. If the lamp's electrode has a ball formed on the end, this indicates that the lamp was used incorrectly. This situation is not covered under warranty.

Discoloration of the terminals of the lamp – particularly the top one – can indicate overheating. Normally the fan on the lamp housing begins to operate a few minutes after the lamp is ignited. The fan speed is regulated so that the lamp is maintained at its optimal temperature.

If the lamp envelope is completely black inside, it may indicate that the seal at one of the terminal end caps has broken. This could be due to rough handling, a lamp defect or a failure when overheated.

Some arc lamps are shipped with a wire around its envelope. This helps to ignite the lamp. Do not remove this wire.

### **13.5 LAMP CARE AND HANDLING**

Do not allow any contaminants or fingerprints to get onto the lamp envelope. Always wear powder-free gloves. Clean the lamp with isopropyl alcohol and dry completely before using. If contaminants are not removed, it may lead to darkening of the lamp envelope, reduced light output, overheating and premature failure.

### **13.6 LAMP HOUSING THERMOSTAT**

The lamp housing is equipped with a shut-off switch which will activate when the lamp housing becomes too hot. The lamp will be shut off and an iLOC error will appear on the power supply display. When the lamp housing temperature returns to normal, the iLOC error will disappear. The lamp housing will require servicing before the lamp is ignited again. Note that overheating will reduce the lamp's life.

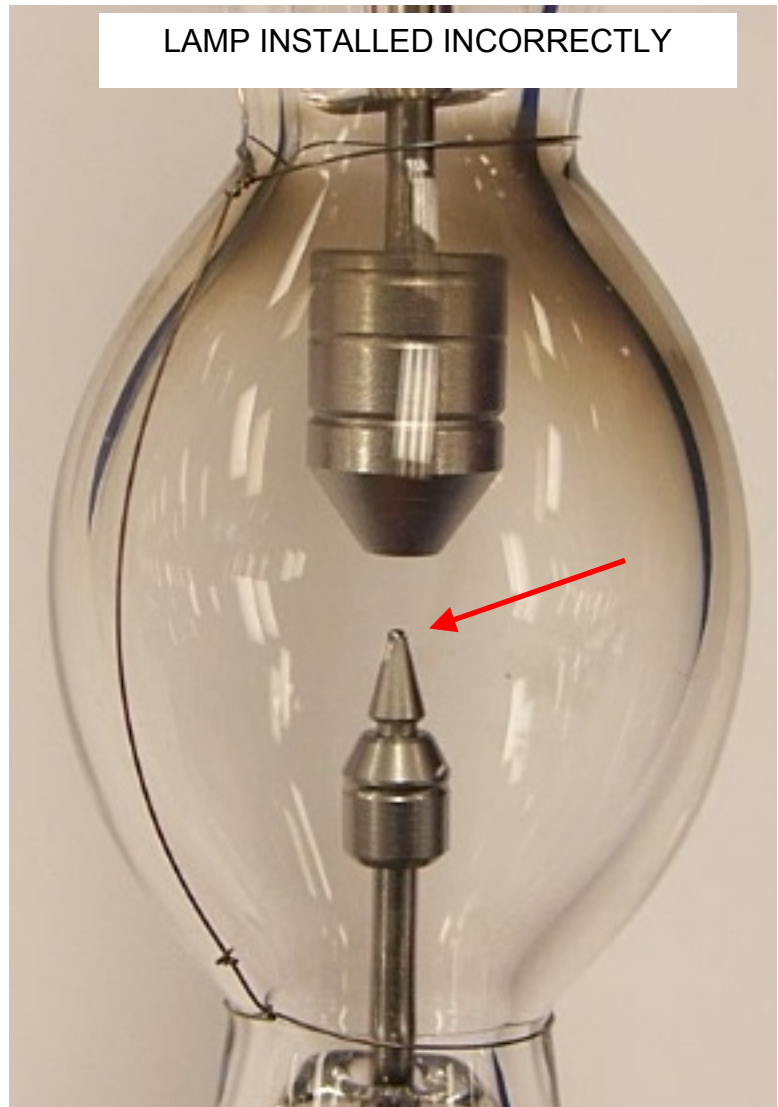

**Figure 79: Arc Lamp Installed Backwards**

## 13.7 GENERAL TROUBLESHOOTING

Check the voltage at the channel 1 detector and compare it to previous data. Optimize the lamp, if indicated. All voltages can be checked in real time by accessing the Utility screen and selecting the multiplexer.

When data is being taken, in addition to being able to display graphs of EQE, IQE, etc., one can also display the raw voltages from each of the detectors. This can help to narrow down the cause of any unusual scans. For example, if the connection to the sample became dislodged, this would be evident by viewing the channel 2 voltage graph.

If any changes are made to the system, such as relocation, lamp replacement or changes to the monochromator input slit, a system verification should be performed after the lamp is optimized. This will indicate whether or not a calibration should be performed.

In the Utilities screen, the instruments that make up the IQE system may be accessed from a pull-down menu. Real-time performance can be assessed, and diagnostics can be run through the Self-Test icon. If an instrument does not pass the self-test, check power and USB cables. Then check the Windows device manager to find out if the instrument is being detected by the computer.

If the data is off by a factor of 10x, 100x, etc., then check to ensure that the light bias amplifier gain settings match those listed in the config.ini file. The gain switches on the reference, Rs and Rd detectors should not be adjusted.

If the graph is not being displayed at all when a scan is being run, it may be due to the type of scan being run. The default graph display is EQE, which is not always available. It depends on the type of recipe being run. For example, a reflectance scan will not display EQE. Click to change the display to another parameter, which would be included with the recipe selected.

In the Utilities screen where the monochromator settings are displayed, one can open or close the monochromator shutter. If green light is not emitted from the IQE system after going to the appropriate wavelength, even when the lamp is on, check that the shutter close icon was not accidentally depressed.

Very unusual data will be recorded if the chopper controller is not set correctly for ACDC systems. For AC scans, the chopper must be running. For DC scans, the chopper must be stopped in the open position. Verify the chopper setting on its display.

If there is virtually no voltage coming from the test sample, even at a wavelength of maximal responsivity, it is possible that the test sample is connected in a reverse polarity. Switch connections and check the voltage again.

## 14 SPECIFICATIONS

### 14.1 PHYSICAL SPECIFICATIONS, ACDC SYSTEM

Ambient Operating Temperature	0 - 40 °C
Weight of System	200 lbs
System Dimensions, L x W x H	60" x 18" x 35" (152 cm x 46 cm x 89 cm)
Shipping Crate Dimensions L x W x H	70" X 34" X 54" (178 cm x 86 cm x 137 cm)
Total shipping weight, without accessories	450 lbs



### 14.2 PHYSICAL SPECIFICATIONS, AC SYSTEM

Ambient Operating Temperature	0 - 40 °C
Weight of System	100 lbs
System Dimensions, L x W x H	38" X 18" X 31" (97 cm x 46 cm x 78cm)
Shipping Crate Dimensions L x W x H	36" X 40" X 48" (178 cm x 86 cm x 137 cm)
Total shipping weight, without accessories	120 lbs

### 14.3 ELECTRICAL SPECIFICATIONS

Input Voltage	100-264 VAC
Input Current	18.5 A
Input Frequency	47 - 63 Hz
Power Consumption	700 W (may vary depending on accessories chosen)
Operating Mode Power Supply (69911)	Constant power (default) or constant current

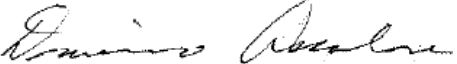
## 15 EU DECLARATION OF CONFORMITY

<b>Manufacturer's name:</b>	Newport Corporation
<b>Manufacturer's address:</b>	150 Long Beach Boulevard Stratford, CT 06615 USA
<b>Declares that the product:</b>	
<b>Product Name:</b>	NEWPORT ORIEL® IQE 200 Series
<b>Model Numbers:</b>	IQE-xx-xx-xx or SPIQE-xx-xx
<b>Type of equipment:</b>	Electrical equipment for measurement, control and laboratory use in industrial locations
<b>conforms to the following Product Specifications:</b>	
<b>Safety:</b>	EN 61010-1:2001
<b>EMC:</b>	EN 61326-1:2006
<b>complies with the following Directives:</b>	
	2004/108/EC EMC Directive 2006/95/EC Low Voltage Directive
<b>and accordingly, carries the CE mark</b>	
<b>CE mark affixed:</b>	Beaune; November 6, 2009
	
Domenic Assalone	Bruno Rety      Authorized to compile technical documentation
Site Manager, Oriel Products Division	Group Director, PPT Instrument and Motion Europe
150 Long Beach Boulevard	Micro-Controle Division of Newport Corporation
Stratford, CT 06615 USA	Zone Industrielle 45340 Beaune la Rolande, France

## 16 APPENDIX I – CABLES AND ADAPTERS

The cables and adapters that are provided with an IQE system are outlined in the section of this manual that covers connecting a sample to the system.

Oriel Instruments recognizes that many possibilities exist in how a sample can be electrically connected, so a number of cables and adapters are offered. These could be used with the basic sample platform, temperature controlled vacuum chuck, probes or with an end user's own fixtures.

For more information or to purchase any of these items, contact Oriel Instruments or regional sales representative.

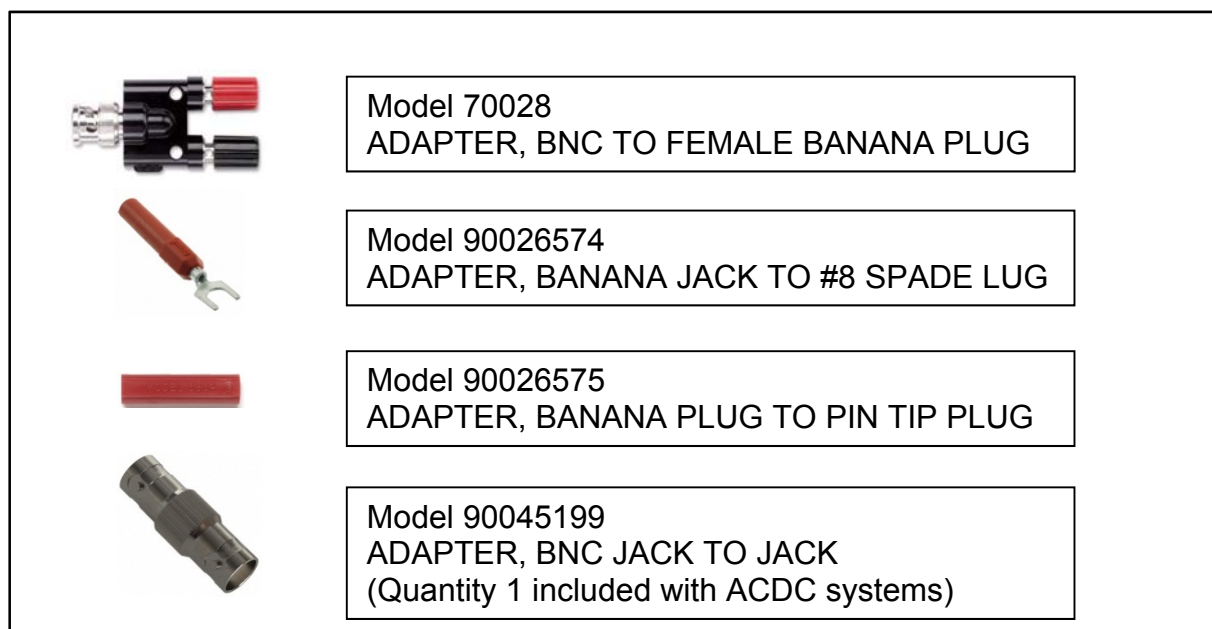

**Figure 80: Connection Adapter Options**



Figure 81: Cable Options

---

## 17 APPENDIX II – LOCK-IN AMPLIFIER BACKGROUND

---

The Merlin™ digital radiometry system is a lock-in amplifier designed with built in support for the Oriel Instruments optical chopper and detector system. This technical note will describe some of the built- in software functions of the Merlin™ digital radiometric system.

### **Filter**

A major advantage of a locked-in detection methodology is the ability to extract very small signals in a high noise environment through a homodyne detection method. As with standard homodyne techniques, a band-pass filter is used to isolate the side-band signal from noise and higher harmonics. The Merlin™ filter selection combines, in one setting, the control of a dual-pole anti-aliasing filter and the infinite series integration time constant.

### **Sync**

The synchronization frequency for the instrument can be set to an internal or external source. When set to internal, the Merlin™ digital radiometry system uses a built in digital frequency synthesizer to generate a reference chopping signal to drive an external chopper and mix with the chopped input signal.

### **Frequency**

When set to internal sync, the frequency function of the Merlin™ controls the chopping frequency of external optical chopper. This value is configurable in 0.1 Hz increments through software settings.

### **Phase**

The Merlin™ offers two choices of phase operation - single or dual pole phase. Under single phase, the instrument outputs the cosine amplitude at a specific phase relative

$$V_x = |R_{sig}| \cos \theta_{sig}$$

where  $V_x$  is the voltage output of the Merlin™ at  $\theta_{sig}$  relative to the reference phase and  $|R_{sig}|$  is the vector amplitude of the desired signal. This mode is useful cross-correlation amplitude resolved measurements such as time-domain spectroscopy where the measured voltage is extracted relative to a defined phase.

In the dual pole option, the measured voltage outputs the vector amplitude of the mixed signal by computing both components of the vector

$$V_x = |R_{sig}| \cos \theta_{sig}$$
$$V_y = |R_{sig}| \cos \left( \theta_{sig} + \frac{\pi}{2} \right)$$

and calculating the amplitude through

$$|R_{sig}| = \sqrt{\left( R_{sig} \cos \left( \theta_{sig} + \frac{\pi}{2} \right) \right)^2 + \left( R_{sig} \cos \theta_{sig} \right)^2}$$

### **Chopper**

When the chopper is turned on, the Merlin™ enters a special calibration mode where the instrument auto-calibrates the chopper to minimize chopper control response time; thereby reducing phase-jitter noise.

## 18 APPENDIX III – SYSTEM PARAMETER DETAILS

---

There are several parameters in new IQE200 software that will affect IQE200 system performance. It is important to understand the definitions of these parameters in order to predict how they will affect the scan/calibration of the IQE200 system.

The External QE calibration parameters are governed by the configuration file (config.ini). This file is also used when calibrating Rs and Rd. When running scans, the parameters are chosen based upon the selected method.

The configuration file contains important setting information for the IQE200 system. The config.ini file sets up the following hardware in IQE200 system.

1. Monochromator
2. Merlin
3. Multiplexer

Using the correct hardware parameters is critical, as it can affect the scan time, sensitivity of measurement and measurement noise.

The Merlin is lock-in amplifier reads the voltage input from the amplified detector. The Merlin also drives the chopper with AC systems. The following Merlin are set in the configuration file:

Frequency: sets the chopper frequency.

Auto-range: sets gain range to auto.

Time Constant: time constant of Merlin.

Time Constant is stored in the configuration file.

0.003S  
0.010S  
0.030S  
0.100S  
0.300S  
1.00S  
3.00S  
10.0S  
30.0S  
100S

Switching Delay: waits for the multiplexer to switch channels and for readings to stabilize  
(units in in msec)

Acquisition Delay: delays reading between samples.  
(units in in msec)

Sample: number of samples to read and average

When the monochromator reaches the target wavelength, the Merlin sets the time constant to 0.003s. This is done to clear the Merlin buffer. Communication with Merlin is not instantaneous, so the IQE200 waits for 250 ms to ensure that the system is ready to receive another command.

If the channel is switched, the Merlin is set to the time constant specified in the configuration file or the Method. The Switching Delay (ms) sets the system to wait for the multiplexer to switch and allows time for the reading to stabilize. This is set from config.ini or Method.

When stabilized, the system acquires data from Merlin (voltage). The system waits for "Acquisition Delay" in ms. If more samples need to be taken, it repeats the process as many times as is needed. All samples are averaged and system repeats this process on the other channels. When measurements on all channels are complete, the system moves to next wavelength

When the monochromator reaches the target wavelength ( $\lambda_n$ ), the Merlin sets the time constant to 0.003s. This is done to clear the Merlin buffer. Communication with Merlin is not instantaneous, so the IQE200 waits for 250ms to ensure that the system is ready to receive another command.

If the channel is switched, the Merlin is set to the time constant specified in the configuration file or the Method. The Switching Delay (ms) sets the system to wait for the multiplexer to switch and allows time for the reading to stabilize. This is set from config.ini or Method.

When stabilized, the system acquires data from Merlin (voltage). The system waits for "Acquisition Delay" in ms. If more samples need to be taken, it repeats the process as many times as is needed. All samples are averaged and system repeats this process on the other channels. When measurements on all channels are complete, the system moves to next wavelength.

The most significant parameters are the Time Constant and Switching Delay. If the Switching Delay is too short, a measurement will be taken while the system is switching between channels. If the Time Constant is too short, the measurement being read would not have had a chance to stabilize.

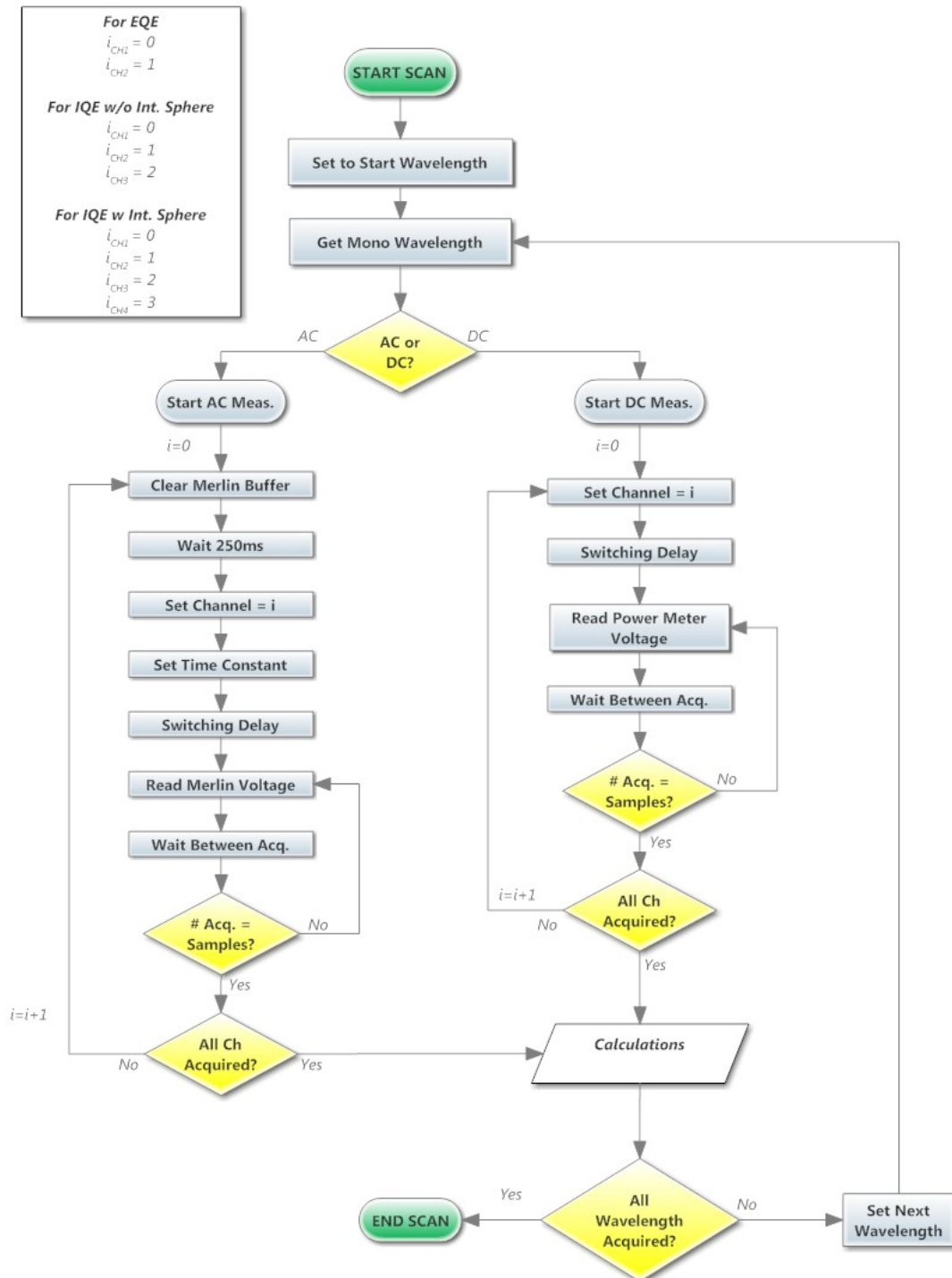

Figure 82: Detailed Scan Flowchart

## 19 WARRANTY AND SERVICE

---

### 19.1 CONTACTING ORIEL INSTRUMENTS

Oriel Instruments belongs to Newport Corporation's family of brands. Thanks to a steadfast commitment to quality, innovation, hard work and customer care, Newport is trusted the world over as the complete source for all photonics and laser technology and equipment.

Founded in 1969, Newport is a pioneering single-source solutions provider of laser and photonics components to the leaders in scientific research, life and health sciences, photovoltaics, microelectronics, industrial manufacturing and homeland security markets.

Newport Corporation proudly serves customers across Canada, Europe, Asia and the United States through 9 international subsidiaries and 24 sales offices worldwide. Every year, the Newport Resource catalog is hailed as the premier sourcebook for those in need of advanced technology products and services. It is available by mail request or through Newport's website. The website is where one will find product updates, interactive demonstrations, specification charts and more.

To obtain information regarding sales, technical support or factory service, United States and Canadian customers should contact Oriel Instruments directly.

Oriel Instruments  
150 Long Beach Boulevard  
Stratford, CT 06615 USA

Telephone: 800-714-5393 (toll-free in United States)  
203-377-8282

Fax: 203-378-2457

Sales: [oriel.sales@newport.com](mailto:oriel.sales@newport.com)  
Technical assistance: [oriel.tech@newport.com](mailto:oriel.tech@newport.com)  
Repair Service: [rma.service@newport.com](mailto:rma.service@newport.com)

Customers outside of the United States must contact their regional representative for all sales, technical support and service inquiries. A list of worldwide representatives can be found on Oriel's website: <http://www.newport.com/oriel>.

## 19.2 REQUEST FOR ASSISTANCE / SERVICE

Please have the following information available when requesting assistance or service:

Contact information for the owner of the product.  
Instrument model number (located on the product label).  
Product serial number and date of manufacture (located on the product label).  
Description of the problem.

To help Oriel's Technical Support Representatives diagnose the problem, please note the following:

Is the system used for manufacturing or research and development?  
What was the state of the system right before the problem?  
Had this problem occurred before? If so, when and how frequently?  
Can the system continue to operate with this problem, or is it non-operational?  
Were there any differences in the application or environment before the problem occurred?

## 19.3 REPAIR SERVICE

This section contains information regarding factory service for this product. The user should not attempt any maintenance or service of the system beyond the procedures outlined in this manual. This product contains no user serviceable parts other than what is noted in this manual. Any problem that cannot be resolved should be referred to Oriel Instruments.

If the instrument needs to be returned for service, a Return Material Authorization (RMA) number must be obtained prior to shipment to Oriel Instruments. This RMA number must appear on both the shipping container and the package documents.

Return the product to Oriel Instruments, freight prepaid, clearly marked with the RMA number and it will either be repaired or replaced at Oriel's discretion.

Oriel is not responsible for damage occurring in transit. The Owner of the product bears all risk of loss or damage to the returned Products until delivery at Oriel's facility. Oriel is not responsible for product damage once it has left the facility after repair or replacement has been completed.

Oriel is not obligated to accept products returned without an RMA number. Any return shipment received by Oriel without an RMA number may be reshipped by Newport, freight collect, to the Owner of the product.

## 19.4 NON-WARRANTY REPAIR

For Products returned for repair that are not covered under warranty, Newport's standard repair charges shall be applicable in addition to all shipping expenses. Unless otherwise stated in Newport's repair quote, any such out-of-warranty repairs are warranted for ninety (90) days from date of shipment of the repaired Product.

Oriel will charge an evaluation fee to examine the product and determine the most appropriate course of action. Payment information must be obtained prior to having an RMA number assigned. Customers may use a valid credit card, and those who have an existing account with Newport Corporation may use a purchase order.

When the evaluation had been completed, the owner of the product will be contacted and notified of the final cost to repair or replace the item. If the decision is made to not proceed with the repair, only the evaluation fee will be billed. If authorization to perform the repair or provide a replacement is obtained, the evaluation fee will be applied to the final cost. A revised purchase order must be submitted for the final cost. If paying by credit card, written authorization must be provided that will allow the full repair cost to be charged to the card.

## **19.5 WARRANTY REPAIR**

If there are any defects in material or workmanship or a failure to meet specifications, notify Oriel Instruments promptly, prior to the expiration of the warranty.

Except as otherwise expressly stated in Oriel's quote or in the current operating manual or other written guarantee for any of the Products, Oriel warrants that, for the period of time set forth below with respect to each Product or component type (the "Warranty Period"), the Products sold hereunder will be free from defects in material and workmanship, and will conform to the applicable specifications, under normal use and service when correctly installed and maintained. Oriel shall repair or replace, at Oriel's sole option, any defective or nonconforming Product or part thereof which is returned at Buyer's expense to Oriel facility, provided, that Buyer notifies Oriel in writing promptly after discovery of the defect or nonconformity and within the Warranty Period. Products may only be returned by Buyer when accompanied by a return material authorization number ("RMA number") issued by Oriel, with freight prepaid by Buyer. Oriel shall not be responsible for any damage occurring in transit or obligated to accept Products returned for warranty repair without an RMA number. Buyer bears all risk of loss or damage to the Products until delivery at Oriel's facility. Oriel shall pay for shipment back to Buyer for Products repaired under warranty.

### WARRANTY PERIOD

All Products (except consumables such as lamps, filters, etc.) described here are warranted for a period of twelve (12) months from the date of shipment or 3000 hours of operation, whichever comes first.

Lamps, gratings, optical filters and other consumables / spare parts (whether sold as separate Products or constituting components of other Products) are warranted for a period of ninety (90) days from the date of shipment.

### WARRANTY EXCLUSIONS

The above warranty does not apply to Products which are (a) repaired, modified or altered by any party other than Oriel; (b) used in conjunction with equipment not provided or authorized by Oriel; (c) subjected to unusual physical, thermal, or electrical stress, improper installation, misuse, abuse, accident or negligence in use, storage, transportation or handling, alteration, or tampering, or (d) considered a consumable item or an item requiring repair or replacement due to normal wear and tear.

**DISCLAIMER OF WARRANTIES: EXCLUSIVE REMEDY**

THE FOREGOING WARRANTY IS EXCLUSIVE AND IN LIEU OF ALL OTHER WARRANTIES. EXCEPT AS EXPRESSLY PROVIDED HEREIN, ORIEL MAKES NO WARRANTIES, EITHER EXPRESS OR IMPLIED, EITHER IN FACT OR BY OPERATION OF LAW, STATUTORY OR OTHERWISE, REGARDING THE PRODUCTS, SOFTWARE OR SERVICES. NEWPORT EXPRESSLY DISCLAIMS ANY IMPLIED WARRANTIES OF MERCHANTABILITY OR FITNESS FOR A PARTICULAR PURPOSE FOR THE PRODUCTS, SOFTWARE OR SERVICES. THE OBLIGATIONS OF ORIEL SET FORTH IN THIS SECTION SHALL BE ORIEL'S SOLE LIABILITY, AND BUYER'S SOLE REMEDY, FOR BREACH OF THE FOREGOING WARRANTY. Representations and warranties made by any person including distributors, dealers and representatives of Oriel / Newport Corporation which are inconsistent or in conflict with the terms of this warranty shall not be binding on Oriel unless reduced to writing and approved by an expressly an authorized officer of Newport.

## **19.6 LOANER / DEMO MATERIAL**

Persons receiving goods for demonstrations or temporary use or in any manner in which title is not transferred from Newport shall assume full responsibility for any and all damage while in their care, custody and control. If damage occurs, unrelated to the proper and warranted use and performance of the goods, recipient of the goods accepts full responsibility for restoring the goods to their original condition upon delivery, and for assuming all costs and charges.

### Confidentiality & Proprietary Rights

**Reservation of Title:**

The Newport programs and all materials furnished or produced in connection with them ("Related Materials") contain trade secrets of Newport and are for use only in the manner expressly permitted. Newport claims and reserves all rights and benefits afforded under law in the Programs provided by Newport Corporation.

Newport shall retain full ownership of Intellectual Property Rights in and to all development, process, align or assembly technologies developed and other derivative work that may be developed by Newport. Customer shall not challenge, or cause any third party to challenge the rights of Newport.

**Preservation of Secrecy and Confidentiality and Restrictions to Access:**

Customer shall protect the Newport Programs and Related Materials as trade secrets of Newport, and shall devote its best efforts to ensure that all its personnel protect the Newport Programs as trade secrets of Newport Corporation. Customer shall not at any time disclose Newport's trade secrets to any other person, firm, organization, or employee that does not need (consistent with Customer's right of use hereunder) to obtain access to the Newport Programs and Related Materials. These restrictions shall not apply to information (1) generally known to the public or obtainable from public sources; (2) readily apparent from the keyboard operations, visual display, or output reports of the Programs; 3) previously in the possession of Customer or subsequently developed or acquired without reliance on the Newport Programs; or (4) approved by Newport for release without restriction.

First printing 2013

© 2013 by Newport Corporation, Irvine, CA. All rights reserved.

No part of this manual may be reproduced or copied without the prior written approval of Newport Corporation.

This manual has been provided for information only and product specifications are subject to change without notice. Any change will be reflected in future printings.

Newport Corporation 1791 Deere Avenue Irvine, CA, 92606 USA  
Models: IQE200