

MARK	QTY	SIZE	RATING	STYLE	DESC.
A	1	4"	150 LB	STUDDED	INLET
B	4	3"	150 LB	OUTLET	OUTLET
C	1	1/2"	-	FNPT	AIR

GENERAL PRESS DATA:

INITIAL PRESS CAPACITY - 59.7 CUBIC FEET
 INITIAL FILTRATION AREA - 1,328 SQ. FT.

UNIT WEIGHTS:

SKELETON - 16,305 LBS
 PLATES - 2,640 LBS
 SHIPPING - 19,300 LBS
 OPERATING - 26,510 LBS

NOTES:

- OPERATING WEIGHT BASED ON CAKE WEIGHT OF 120 LBS/CU FT.
- ALL DIMENSIONS IN INCHES [mm].
- PNEUMATIC SHIFTER:
AIR REQ'D: 70 PSIG @ 25 SCFM/CYCLE
- PLATE STACK DIMENSION INCLUDES ALLOWANCE OF 1/16" PER PLATE.
- FILTER PRESS IS DESIGNED FOR ZERO BACK PRESSURE.
- PRESS CONTROL CENTER IS LOCATED ON THE "OPERATING SIDE" OF THE THE FILTER PRESS.
- ALL CARBON STEEL SURFACES TO BE EPOXY PAINTED SAFETY BLUE.
- ALL FLANGE BOLT HOLES ARE TO STRADDLE NATURAL CENTERLINES.
- LINER PIPE MATERIAL AT LIQUID CONTACT POINTS IS POLYPROPYLENE.

		FILTER PRESS DESIGN / OPERATING CONDITIONS		
		FILTER / WASH		SQUEEZE
OPERATING PRESSURE	MAX.	100 PSIG	6.89 BAR	7.03 kg/cm ²
OPERATING TEMPERATURE	MAX.	121 °F	49.44 °C	
HYDRAULIC PRESSURE REQUIRED TO CLOSE	MIN.	3,194 PSIG	220.22 BAR	224.56 kg/cm ²
	MAX.	3,387 PSIG	233.53 BAR	238.13 Kg/cm ²
AIR PRESSURE SETTING	MIN.	55 PSIG	3.79 BAR	3.87 kg/cm ²
	MAX.	58 PSIG	4.00 BAR	4.08 kg/cm ²
RELIEF VALVE SETTING	-	3,726 PSIG	256.88 BAR	261.94 kg/cm ²

NOT APPLICABLE

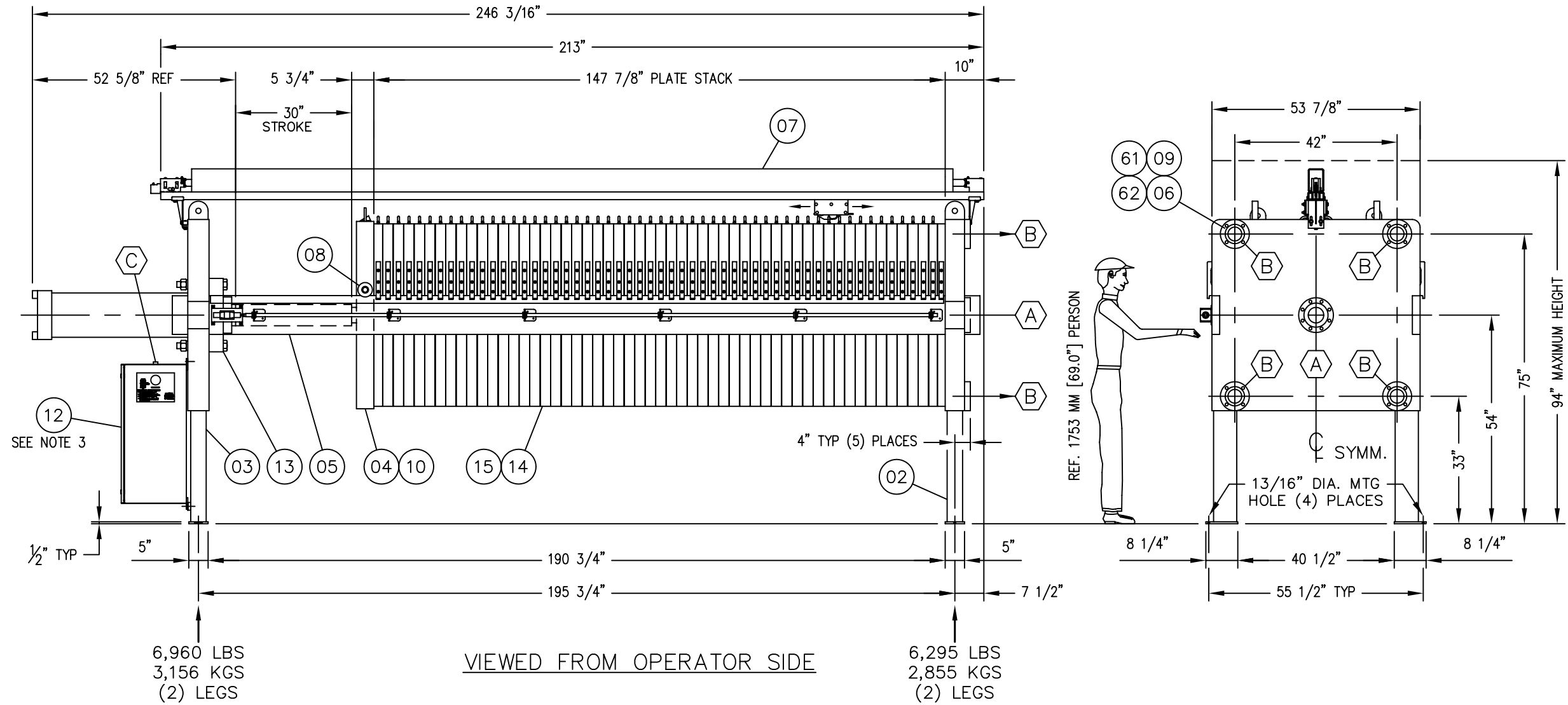

CERTIFIED
 Bruce W. Hindle 3:07 pm, 3/15/05

UNLESS OTHERWISE NOTED, ALL MACHINE SURFACES TO HAVE 125 RMS FINISH				
UNLESS OTHERWISE NOTED, TOLERANCES ARE				
ANGLES: ± 1/2"				
FRACTIONS: ± 1/16"				
DECIMAL:				
.X ± .03				
.XX ± .010				
.XXX ± .005				
.XXXX ± .0005				
1	JC	3/8/05	UPDATED SHIFTER & LIFT LUGS	
REV	BY	DATE	DESCRIPTION	

ASCENSION INDUSTRIES
 NORTH TONAWANDA, NEW YORK 14120

Title: **EP1200 (100 PSI) ASSEMBLY**
 EPG 1200/32-53 FILTER PRESS

Scale: 3/8" = 1' Drawn By: J. CERNE 2-21-05
 Checked:

SIZE	Dwg.Number	Sheet	Con't.On	Rev
B	FP05048-EP01	001	LAST	1

G:\filtration\Div\Equipment\Orders\Filtr.Press\MICROBE EP05048-EP01.dwg, 3/15/2005 1:11:57 PM