

9450 | SIMPLY EFFICIENT

PRINT MORE. EFFICIENCY BUILT IN ■ ■ ■

Relax thanks to its improved design and ease of use

SMART DESIGN. LOWEST TCO

Up to 20% reduction in consumable use and energy consumption*. Minimized waste expenses.

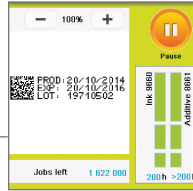

EASY AND MISTAKE PROOF OPERATION

Clean and secure, our innovative cartridge system requires no set-up and eliminates consumable management errors.

EFFICIENT HYGIENIC WASHDOWN DESIGN (IP56)

Clean with pressured water and industrial detergent to achieve your hygiene standards.

CODE BEYOND THE MESSAGE ■ ■ ■

Support your marketing campaigns while achieving your traceability and sustainability goals

PROMOTIONAL CODING FUNCTION

Transfer the data for your promotional coding with a standard USB thumb drive directly to the printer.



LARGE CHOICE OF CODES AND LANGUAGES

Text, Logos, 2D and QR Codes and more all available in 35 languages.

INKS THAT HELP ACHIEVE YOUR TRACEABILITY AND SUSTAINABILITY GOALS

Ink references with a high level of adhesion, contrast and color as well as anti-diversion solutions and environmentally friendly inks.



PREVENT PRODUCT RECALLS AND WASTE ■ ■ ■

Enhanced user experience coupled with the latest vision system to ensure your product is coded right and eliminate scrap

MARK & READ IT DIRECTLY ON YOUR PRINTER. CODE SECURED

Code integrity is automatically checked via the new embedded vision system allowing you to avoid product waste.



TRACK YOUR RUNNING COSTS

Smart monitoring system. Easy access to maintenance and production history (availability rate, additive consumption and number of printed messages).

INDUSTRY LEADING AVAILABILITY

Secure the initial performance of your equipment for 36, 48, or 60 months with our warranty extension.



20% FASTER*

Don't let other competitive models slow you down.

ENHANCED USER EXPERIENCE

Configure the job and lock it directly on the color touch screen.

CENTRALLY MANAGE CODES

Create images and network printers with optional CoLOS® software.

*Compared to other competitive models

PRINT FEATURES

- ▶ Mono-jet printhead
- ▶ G head (printing resolution: 71 dpi)
- ▶ M head (printing resolution: 115 dpi)
- ▶ Up to 5 lines of print
- ▶ Print speed: up to 6.6 m/s
- ▶ Font height from 5 to 32 dots
- ▶ Character height: from 1.2 to 11.2 mm
- ▶ Wide choice of 1D and 2D barcodes: EAN8/EAN13/UPCA/UPCE barcodes, code 39, interleaved 2 of 5, Datamatrix, QR code
- ▶ Wide choice of characters: Latin, Arabic, Cyrillic, Hebrew, Japanese, Chinese, Korean, etc.

OPERATIONS

- ▶ Message library (up to 1,000 messages)
- ▶ International operator/machine interface with a wide choice of languages
- ▶ WYSIWYG 7-inch wide touch screen: realtime display of remaining print capacity expressed in hours and number of messages; integrated assistance and alert system; simplified message printing and management; creation of user profiles; tracking of consumption and printer availability
- ▶ USB and SD ports
- ▶ Jet Speed Control guarantees marking quality
- ▶ Automatic selection of fonts, depending on print speed and printhead/object distance
- ▶ Broad range of inks: multi-use, high performance; alcohol-based, ketone-free and MEK-free inks
- ▶ Sealed 0.8-liter cartridges with foolproofing system
- ▶ Quick connect/disconnect of accessories (photocell, alarm and encoder)
- ▶ Parent/child connectivity
- ▶ Ethernet connectivity
- ▶ Specific date management (rounding date function)

OTHER CHARACTERISTICS

- ▶ Weight: 25 kg
- ▶ Table-top or vertical mounting
- ▶ Ultra-flexible 3-meter umbilical cable
- ▶ Stainless steel cabinet and printhead case
- ▶ Dust/humidity protection rating: IP56 not requiring plant air
- ▶ Operating temperature range: 0 to 40°C depending on ink used
- ▶ Humidity: 10 to 90% non-condensing
- ▶ Electrical power supply: 100-120 V or 200-240 V with automatic switching; frequency 50/60 Hz; power 60 VA

OPTIONS

- ▶ Promotional coding and Mark and Read
- ▶ IP66 protection (requires plant air)
- ▶ 9450 c for pigmented ink use
- ▶ Ultrarapid mode for high-speed printing
- ▶ Printhead pressurization kit
- ▶ RS-232/422 connectivity, parallel interface, many I/O possibilities to enable remote operation
- ▶ Ultra-flexible 6-meter umbilical cable

ACCESSORIES

- ▶ Printer supports: stands (stainless steel or aluminum), table or wall mounting brackets
- ▶ Printhead supports: stand (stainless steel) and choice of brackets
- ▶ Photocells
- ▶ Encoders
- ▶ Alarm beacons (24 V)

SOFTWARE

- ▶ Compatible with CoLOS Create Professional and CoLOS Enterprise
- ▶ Logo creation with CoLOS Graphics
- ▶ OEM protocol compatibility: MOBA, Staalkat

Printhead

Minimum radius of curvature of the umbilical:

- Static: 100 (3.93")
- Dynamic: 150 (5.90")

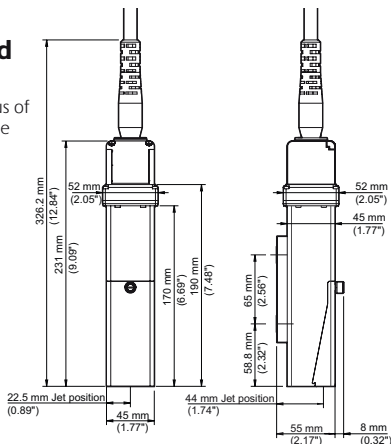

Cabinet

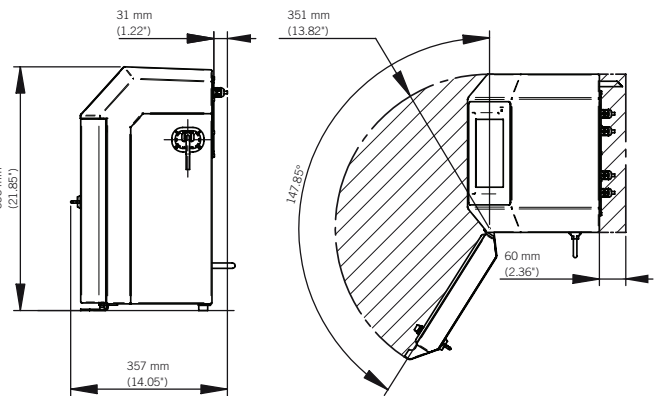
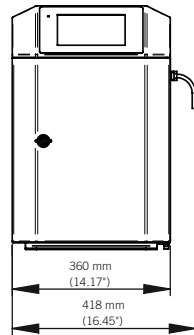

We reserve the right to amend the design and/or specifications of our products without notice.

150 Congress Street
Keene, NH 03431
United States of America
Tel: 800-258-5356
Fax: 603-357-1835

100 Chastain Center Blvd
Suite 165
Kennesaw, GA 30144
United States of America
Tel: 770-421-7700
Fax: 770-421-7702



markem·imaje

a DOVER company

To learn more, visit www.markem-imaje.com

