

Automatän

JOGGER/AERATORS

SIMPLE, FAST AND EFFICIENT

**Superior
by Design**

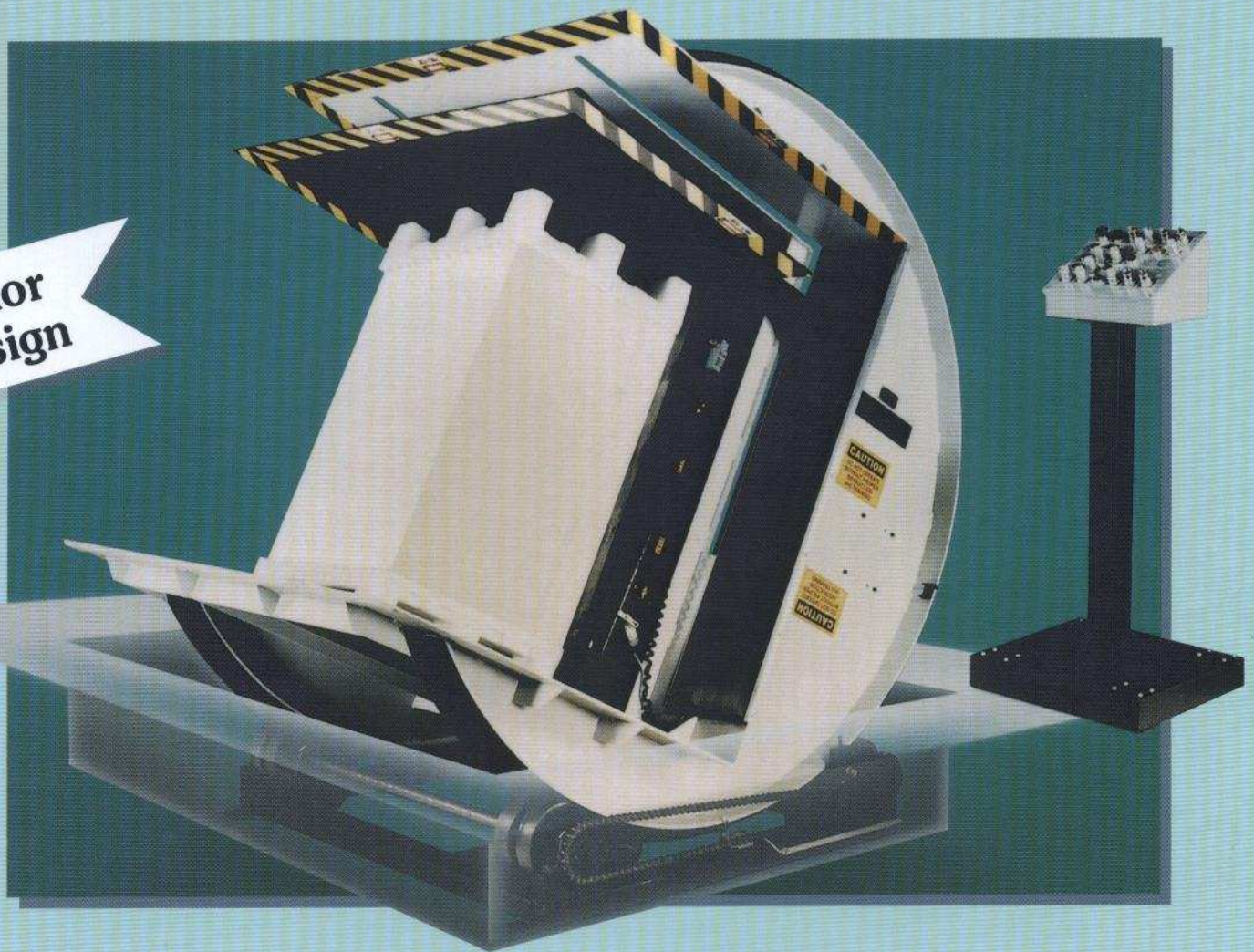

*Inverting • Aerating • Jogging • Cleaning
Sorting • Squaring • Inspecting*

Automatän

Innovative equipment for packaging and printing industry leaders.

Fast, Easy, One Person Handling Of Pallet-Sized Loads

Jogger/Aerators from Automatän reduce cost while improving product and productivity

Cost savings add up to big payoff

Whether turning, jogging and aerating large sheets in a printing operation, or changing pallets for shipping, manual handling of large loads can be time consuming, back breaking and expensive. The Automatän Jogger/Aerator reduces these tasks to a simple, one person operation that produces an evenly stacked pile of sheets in a fraction of the time required for manual aerating and stacking. Based on conservative estimates of labor savings alone, it is possible to pay for an Automatän Jogger/Aerator in less than a year.

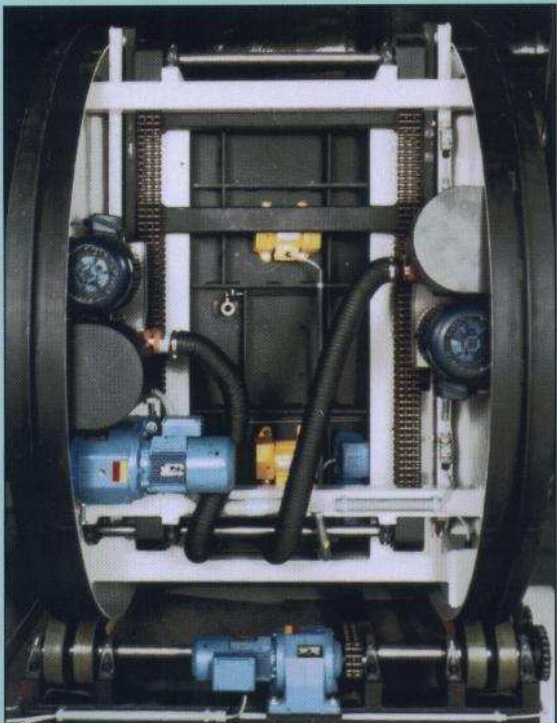

Press plate drive assembly and air and vibration systems are installed in the rear panel of the jogger/aerator and are easily accessible for routine maintenance and service.

Improving finished product and plant productivity

The Automatän Jogger/Aerator improves the condition of the product it handles. Jogging brings the gripper and side guide edges of the load into perfect alignment. Aerating separates sheets and blows out entrapped offset powder, dust and scrap from the loads. Cleaning and aligning loads improve the running speed and performance of downstream printing or converting processes. Partial pallet loads can easily be combined to form full loads. Poor quality material can be identified and culled from the load.

Simple all mechanical design and rugged construction assure years of dependable service

The Automatän Jogger/Aerator concept is as simple and as basic as the wheel, and offers years of safe, efficient, low maintenance operation. Using circular steel side frames cradled on heavy rollers, it requires only one small electrical motor to effortlessly turn even the largest loads. Each load is securely held within the jogger/aerator by a mechanically operated press plate and the entire machine rotates on the cradle.

Photo eyes are in place to ensure safety by preventing machine operation if anything is too close to the machine for safe operation. The operator can reset the machine by simply clearing the photo eye safety beam and manually restarting the cycle.



This Model A73VA is installed in a shallow pit for easy floor level loading using a standard pallet jack.

The ultimate in versatility and performance

The Automatån Jogger/Aerators are available in a range of sizes and formats that will meet your requirements. (Refer to Specifications chart on back cover of brochure.)

Finger tip control

Automated push button operation allows a single operator to easily invert, aerate, jog and square pallet-sized loads. The automatic aeration and jogging cycle begins when the load reaches the 90° position and the sheets are resting against the working deck.

As the air travels from the top to the bottom of the load, it can be stopped anywhere in the load allowing sheets to easily be removed, inspected and re-inserted.

The adjustable air and vibration features enable the operator to jog and aerate a wide variety of sheet sizes and substrates.



Air flow is directed through rows of holes in the air deck by narrow openings in the traveling air belt.

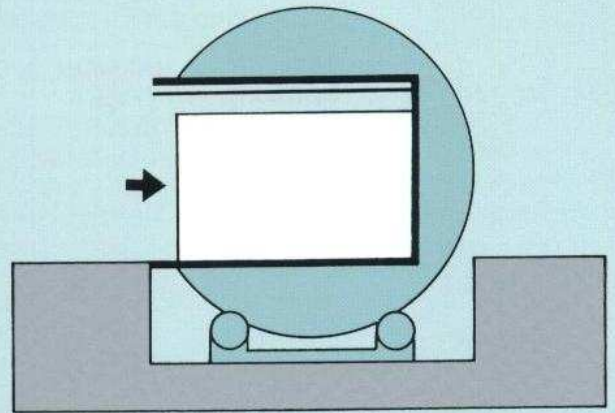

The base of the jogger/aerator is installed in a pit so that loading and unloading can be done at floor level. The press plate is lowered to secure the load before turning. Loading can also be done from the press plate side.

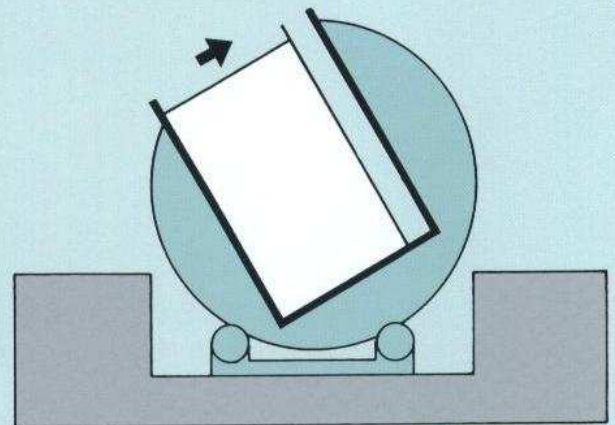

The pile is turned 180° in seconds. When jogging and aerating, the pile is turned 90° to bring the sheets to a vertical position.

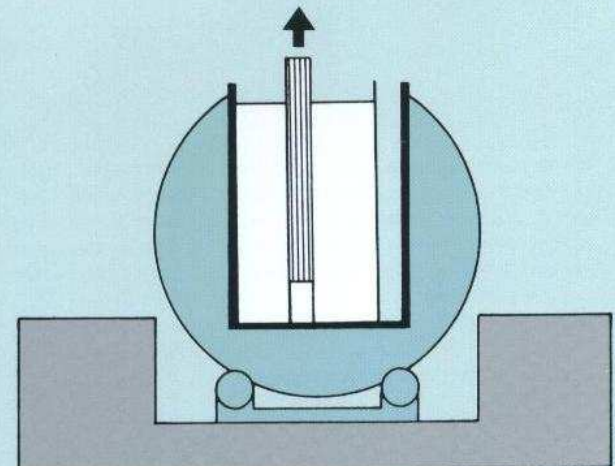

Pressure is released from the press plate to allow air flow between the sheets. At the same time, vibration in the working platform aligns the sheets against the alignment bar.

Specifications

MODEL	LOAD SPECIFICATIONS			MACHINE SPECIFICATIONS				
	MAXIMUM FORMAT		MAXIMUM PILE HEIGHT INCLUDING PALLET	CAPACITY	WIDTH OF OPENING	HEIGHT OF OPENING	MACHINE WEIGHT	POWER REQUIREMENTS* 460 VOLTS, 60 HZ
	A	B	C		D	E		
A 65 VA	28" x 40" (710 x 1040 mm)		58" (1470 mm)	1750 lbs (800 kg)	60.5" (1540 mm)	65" (1650 mm)	8900 lbs (4040 kg)	30 amps
A 73 VA	43" x 65" (1090 x 1650 mm)		67" (1700 mm)	4500 lbs (2040 kg)	78.75" (2000 mm)	73" (1850 mm)	9400 lbs (4260 kg)	50 amps
A 83 VA	43" x 65" (1090 x 1650 mm)		77" (1960 mm)	5500 lbs (2490 kg)	78.75" (2000 mm)	83" (2110 mm)	10800 lbs (4900 kg)	50 amps

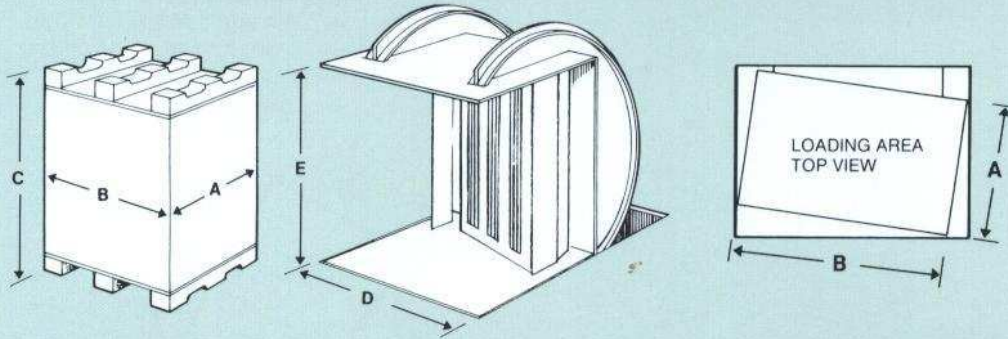

*Other voltages available.

NOTE: The A 83 VA Jogger/Aerator is available in an extended format size of 54" x 78" (1370 x 1980 mm).

Machine space requirements and recommended* minimum clearance from stationary objects.

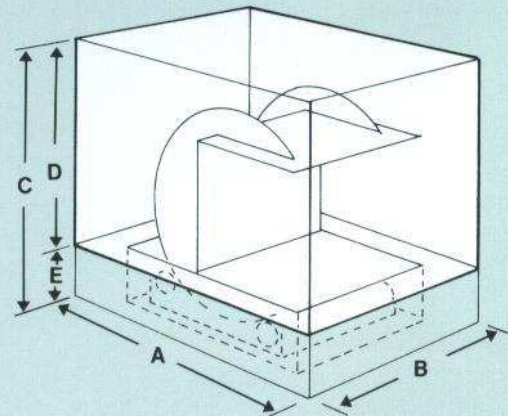
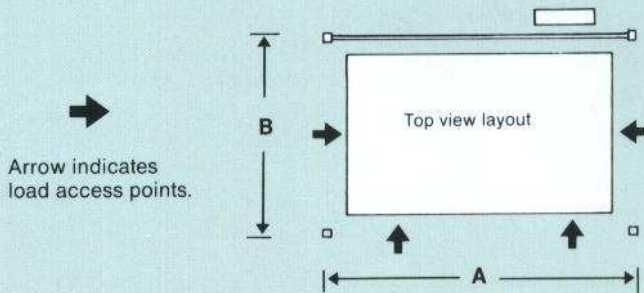

*These measurements represent minimum operational clearances from building support columns, overhead trusses, beams and utilities. Additional space adequate for loading/unloading, electrical cabinet and operator convenience must be allowed. The product, product flow and pallet handling equipment in each plant affect additional space requirements for loading/unloading in your plant.
NOTE: While these specifications may be used for general site planning, they **SHOULD NOT** be used for site preparations. All specifications are subject to change without notice.

SIZE	A	B	C	D	E
65	94" (240 mm)	74" (1880 mm)	94" (2390 mm)	77" (1960 mm)	16.5" (420 mm)
73	134.50" (3420 mm)	109.50" (2780 mm)	106" (2690 mm)	87" (2210 mm)	19" (480 mm)
83	138.50" (3520 mm)	109.50" (2780 mm)	116.25" (2950 mm)	97.25" (2470 mm)	19" (480 mm)

For a real opportunity to increase productivity, call Automatän today.

Automatän