

# 1/4" – 2" (DN 8 – 50) A-style threaded end Jamesbury™ 2000 CWP ball valve

The A-Style ball valve, brings you the performance and design features you've been looking for – all in a single, low-cost valve.

This ball valve's unique design offers fire-test specifications, rugged actuator mounting and flexible-lip seats for application versatility that surpasses other ball valves. Intended for replacement of existing installed product only.

The A-Style ball valve is available in 1/4" – 2" (DN 8 – 50) sizes rated by the traditional approach for threaded end valves. This approach determines Cold Working Pressure (CWP) based on paragraph UG101 of the ASME Boiler and Pressure Vessel Code. Accordingly, the CWP of this series is as follows:

Valve Size		CWP Rating	
inches	DN	psi	bar
1/4" – 2"	8 – 50	2000	138

A-Style valves are available in carbon and stainless steel and are rated for steam applications with Xtreme™ (X), PTFE (T) and Acetal (R) seats.

## FEATURES

### Reliable Bi-Directional Shutoff

- New Xtreme seat provides longer life, expanded performance boundaries and greater value.

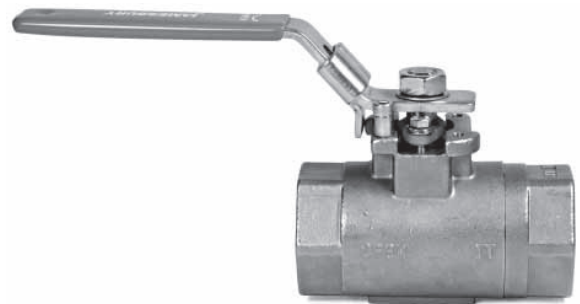

- Polymeric flexible lip-seat design offers tight shut-off in either direction and extended cycle life with minimum maintenance.

### Fire-Tested

- Fire-Tite™ valves meet API 607 requirements.

### NEW FEATURES AND BENEFITS

- New patented stem seal system is live loaded and engineered to assure long sealing life.
- ISO 5211 Bonnet for global conformity.
- New stainless steel linkage for VPVL, V-Series and ADC-Series actuators has a guided coupling to align topworks during assembly and eliminate side load stress on stem seals for long life, clean environment and reduced maintenance.

### Rugged Valve/Actuator Interface Simplifies Automation

- Jamesbury actuators and linkage support up to a 200 lb. load in any direction without causing actuator misalignment and consequent stem seal leakage.

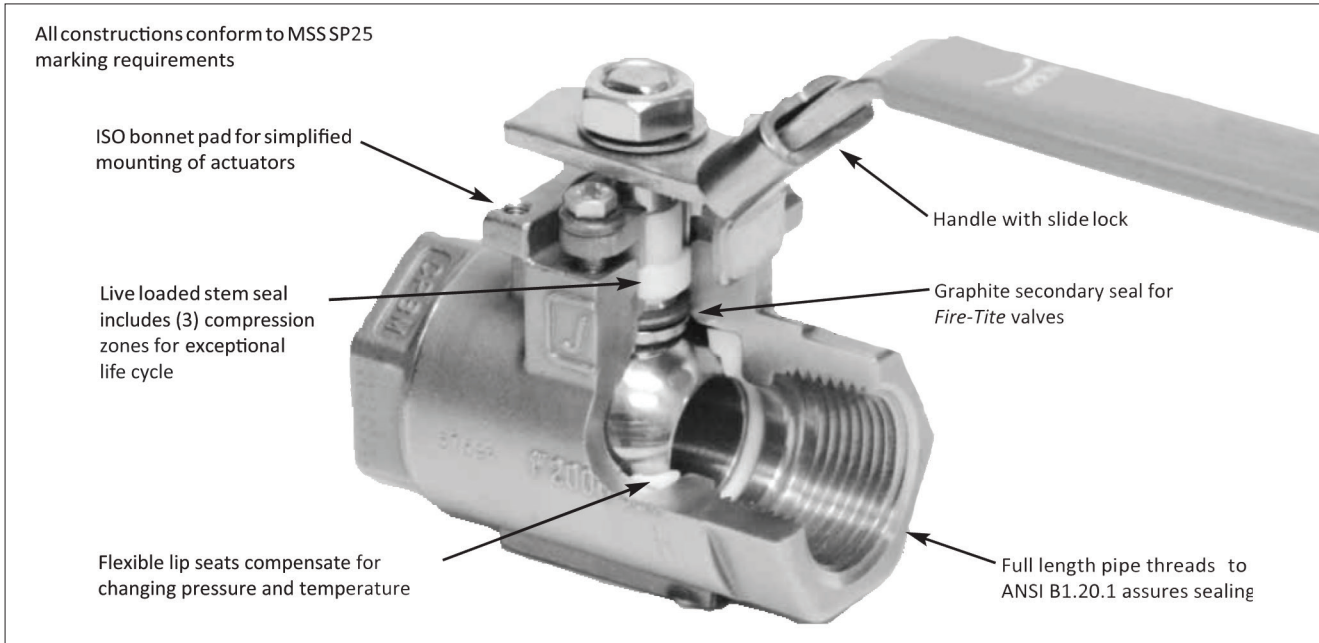

### XTREME PERFORMANCE & VALUE

Xtreme seats provide longer life, expanded performance boundaries and the greatest possible value. Xtreme is a unique material that resulted from a technological breakthrough in our polymer research lab. The material is a fluoropolymer blend, that provides superior quarter turn valve performance.

#### Valve seat ratings

These ratings are based on differential pressure with valve in the fully closed position and refer to seats only. Refer to valve body ratings to be sure that all components are satisfactory for the application.

#### Valve body ratings

These are maximum working pressure ratings of the valve body only. Valves in carbon steel are suitable for service to -20°F (-29°C), valves in 316 stainless steel to -60°F (51°C) (to -40°F with Acetal seats). The preceding seat ratings determine the practical pressure limitation in actual working pressure. Ratings are at -20°F to +100°F (-29°C to +38°C).

1/4" – 2" (DN 8 – 50) Standard Port

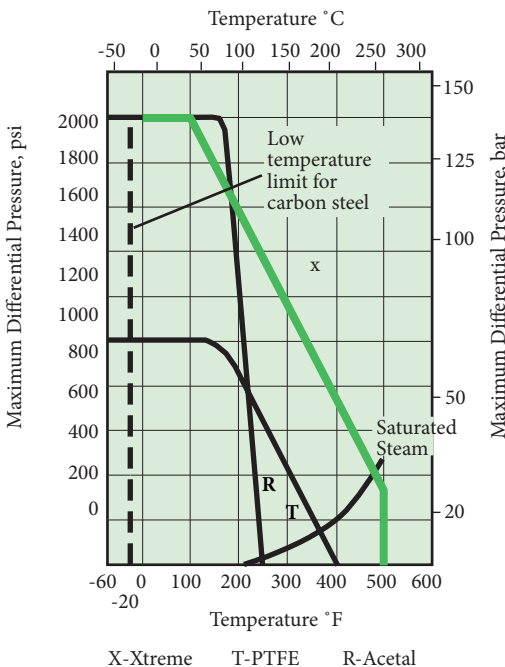

Valve Size Inches	Working Pressure Rating - psi	
	Carbon Steel	Stainless Steel
1/4" – 2"	2000	2000

Valve Size DN	Working Pressure Rating - bar	
	Carbon Steel	Stainless Steel
8 – 50	138	138

### The Ultimate Process Automation Package for VPVL Pneumatic Actuators, V-Series, ADC-Series, QX-Series and I-Series Electric Actuators

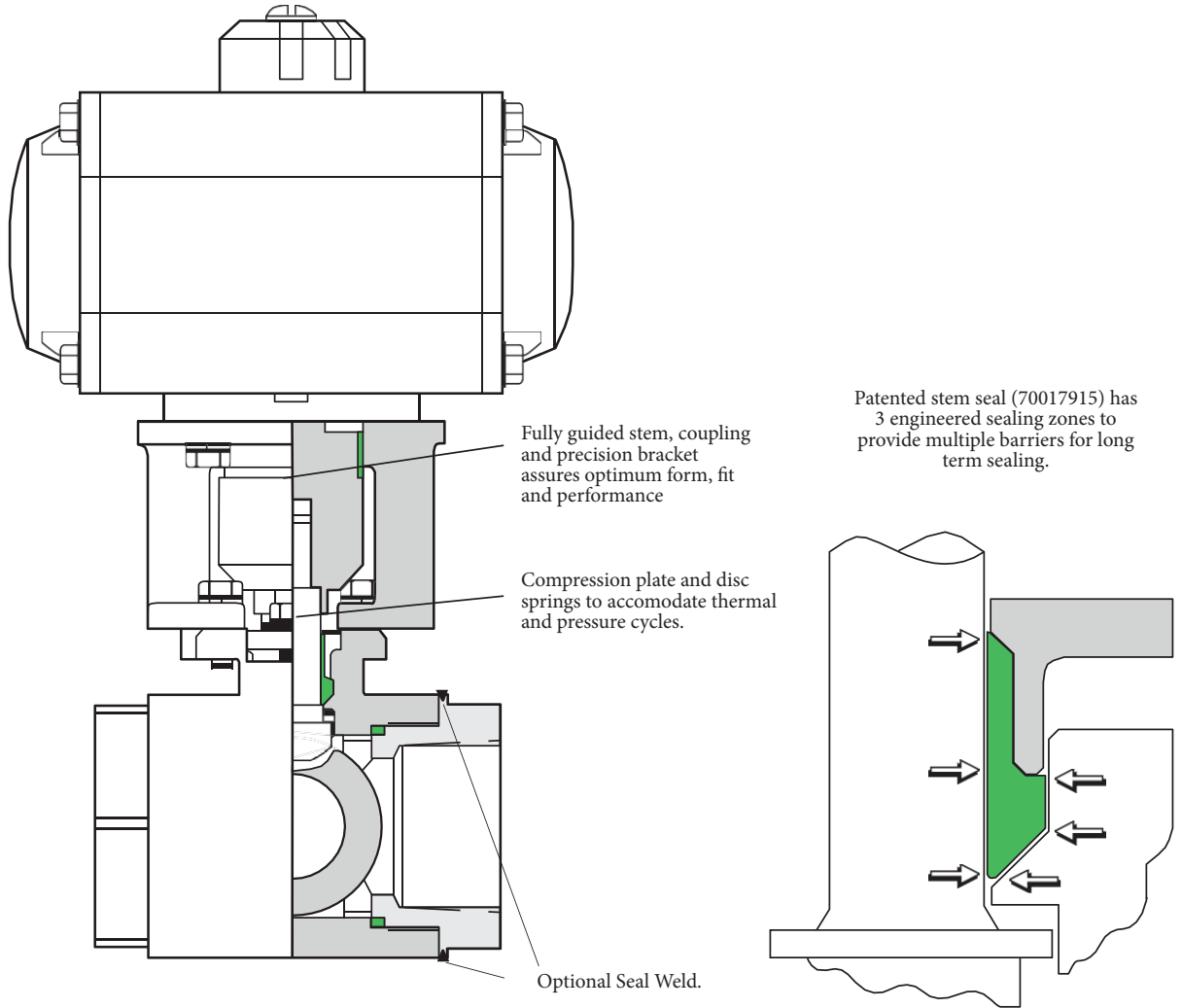

### Automation Performance and Value

A-Style valves combined with Jamesbury actuators offer a total value and performance package. Available with pneumatic Valv-Powr™ VPVL actuators, Valvcon™ V-Series, ADC-Series, QX-Series and I-Series electric actuators and with Stone™ Quartz™, Eclipse™, and Hawkeye™ digital monitors or VCTs, the packages have a wide range of applications. Visit our website at [www.valmet.com/flowcontrol](http://www.valmet.com/flowcontrol).

## DIMENSIONS

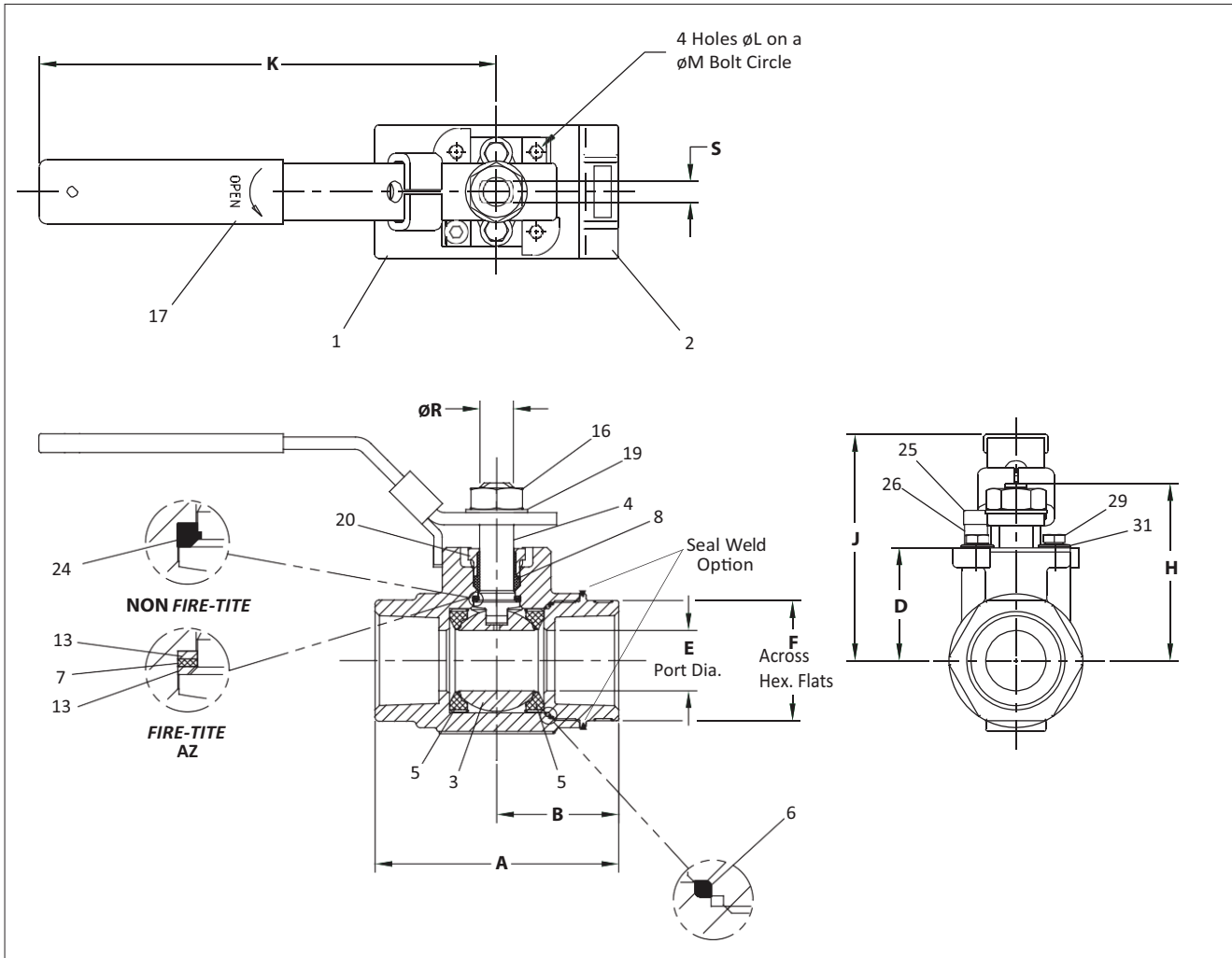

Valve Size Inches	APPROXIMATE DIMENSIONS - inches													Weight lbs.
	A	B	D	E	F	H	J	K	L	M	R	S	ISO BONNET	
1/4	2.94	1.66	1.06	0.43	1.13	1.63	2.36	5.00	M5	1.42	0.31	0.18	F03	1.3
3/8	2.94	1.66	1.06	0.43	1.13	1.63	2.36	5.00	M5	1.42	0.31	0.18	F03	1.3
1/2	3.44	2.16	1.06	0.50	1.13	1.63	2.36	5.00	M5	1.42	0.31	0.18	F03	1.5
3/4	3.81	2.31	1.22	0.69	1.38	1.79	2.52	5.00	M5	1.42	0.31	0.18	F03	2.5
1	4.50	2.73	1.65	0.88	1.75	2.58	3.29	6.50	M5	1.65	0.50	0.31	F04	3.5
1-1/4	4.44	2.44	1.78	1.00	2.00	2.71	3.42	6.50	M5	1.65	0.50	0.31	F04	3.8
1-1/2	4.56	2.37	2.08	1.25	2.31	3.30	4.27	8.00	M6	1.97	0.63	0.37	F05	5.4
2	5.00	2.25	2.26	1.50	2.81	3.49	4.46	8.00	M6	1.97	0.63	0.37	F05	7.0

Valve Size DN	APPROXIMATE DIMENSIONS - mm													Approx. Weight kg
	A	B	D	E	F	H	J	K	L	M	R	S	ISO BONNET	
08	75	42	27	11	29	41	60	127	M5	36	08	05	F03	0.6
10	75	42	27	11	29	41	60	127	M5	36	08	05	F03	0.6
15	87	55	27	13	29	41	60	127	M5	36	08	05	F03	0.7
20	97	59	31	18	35	45	64	127	M5	36	08	05	F03	1.1
25	114	69	42	22	44	65	84	165	M5	42	13	08	F04	1.6
32	113	62	45	25	51	69	87	165	M5	42	13	08	F04	1.7
40	116	60	53	32	59	84	108	203	M6	50	16	09	F05	2.4
50	127	57	57	38	71	89	113	203	M6	50	16	09	F05	3.2

BILL OF MATERIALS AND PARTS LIST			
Part No.	Part Name	Body Material	
		Carbon Steel (22)	316 Stainless Steel (36)
1	Body	Carbon steel ASTM A216 Type WCB	316 Stainless steel ASTM A351 Type CF8M
2	Body Cap	Carbon steel ASTM A216 Type WCB	316 Stainless steel ASTM A351 Type CF8M
3	Ball	316 Stainless steel	
4	Stem	316 Stainless steel or 17-4 PH Stainless steel	
5	Seat	PTFE, Xtreme, Acetal#, as specified	
6	Body Seal	TFM*	
7	Secondary Stem Seal	Graphite*	
8	Stem Seal	PTFE, TFM (Xtreme seated valves)	
13	Stem Bearing	Filled PTFE (Acetal when Acetal seated)	
16	Hex Nut	316 Stainless steel	
17	Handle	Carbon steel (Zinc plated)	300 Series Stainless steel
19	Lock Washer	400 Series Stainless steel	
20	Compression Plate	316 Stainless steel	
25	Socket Cap Screw	316 Stainless steel	
26	Handle Stop Spacer	316 Stainless steel	
29	Hex Cap Screw	316 Stainless steel	
31	Disc Spring	17-7 PH Stainless steel	

# Requires 17-4 PH stem

\* Item 7 not applicable in non Fire-Tite valves

## ACCESSORIES

### Bonnet Extension SE-096, 097 & 098

4" (102 mm) bonnet extensions are available for applications that require insulated pipe, particularly useful for automated products, bonnet extension can also be used to prevent interference between actuators and companion pipelines and equipment. They are ideal as extension that require locking lever or locking oval handle capability. Stainless steel construction offers the option of using the bonnet extension to enhance the carbon steel stem extension (SE-093, 094 & 095) offerings.

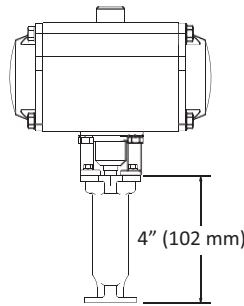

### Round Handles

Optional round handles available. To order handles separately, specify the part number shown in the accessories table below.

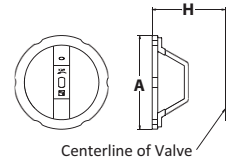

### Oval handles with slide-lock

Optional oval handle saves space and may be padlocked to retain the valve in the open or closed position.

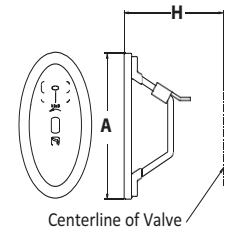

### Stem Extensions SE-093, 094 & 095

A standard 4" (102 mm) stem extension is offered for improved accessibility, particularly when used in insulated pipelines. Stem extension kits can be ordered factory-mounted or shipped separately for field mounting.

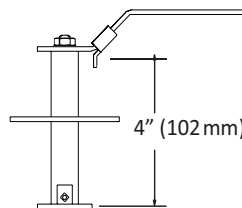

### Stainless steel linkages for Jamesbury ISO Actuators

- Self aligning
- Engineered for optimum stem seal performance

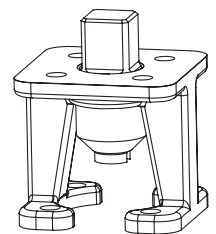

Accessories Table - inches (DN/mm)								
Valve Size Standard Bore	Bonnet Ext.*	Stem Ext.	Locking Oval	Round	Round/Oval Handle		Allowable Max. Torque FT•LBS	
					Dimension A	Dimension H	Round	Oval
1/4 – 1/2 (8 – 15)	SE-096	SE-093	112-0108-30	112-0105-30	4.00 (101.6)	2.96 (75.2)	9 (14)	9 (14)
3/4 (20)	SE-096	SE-093	112-0108-30	112-0105-30	4.00 (101.6)	3.11 (79.0)	9 (14)	9 (14)
1 (25)	SE-097	SE-094	112-0109-30	112-0106-30	4.50 (114.3)	3.70 (94.0)	18 (25)	18 (25)
1-1/4 (32)	SE-097	SE-094	112-0109-30	112-0106-30	4.50 (114.3)	3.83 (97.3)	18 (25)	18 (25)
1-1/2 (40)	SE-098	SE-095	112-0110-30	112-0107-30	5.75 (146.0)	4.75 (120.7)	25 (34)	25 (34)
2 (50)	SE-098	SE-095	112-0110-30	112-0107-30	5.75 (146.0)	4.94 (125.5)	25 (34)	25 (34)

\* Use with Acetal seats

## VALVE TORQUE DATA

These torque charts are to be used as a guide for actuator selection. Additional requirements may be imposed by media characteristics, trim, and frequency of valve operation. For clean lubricating fluid service, required torque of Xtreme (X), and PTFE (T) seated valves only may be reduced 20% when the valve is equipped with corrosion resistant trim. For difficult services such as slurries and semi-solids, and for

oxygen, increase values by 50%. If in doubt, select the larger actuator.

Torque output values and actuator selection tables for the different types of Jamesbury actuators are contained in the bulletins listed on Page 7.

**Xtreme (X) Seated Standard-Port Valves**  
Maximum Differential Pressure - bar

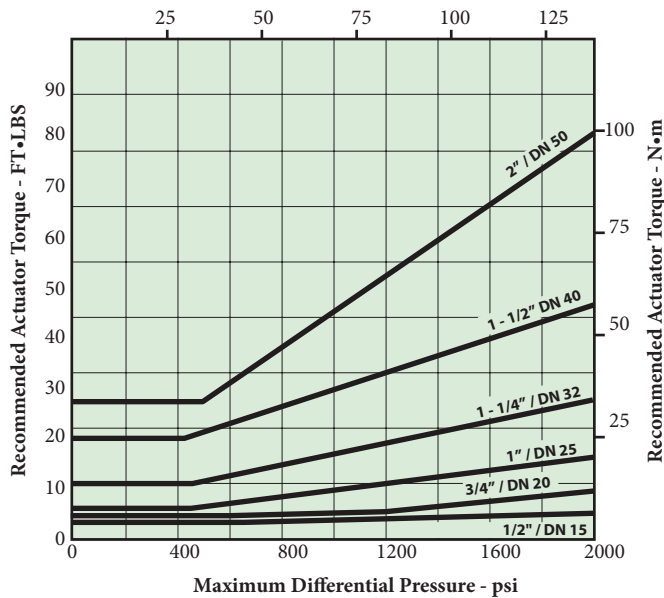

**Acetal Seated Valves**

Maximum Differential Pressure - bar

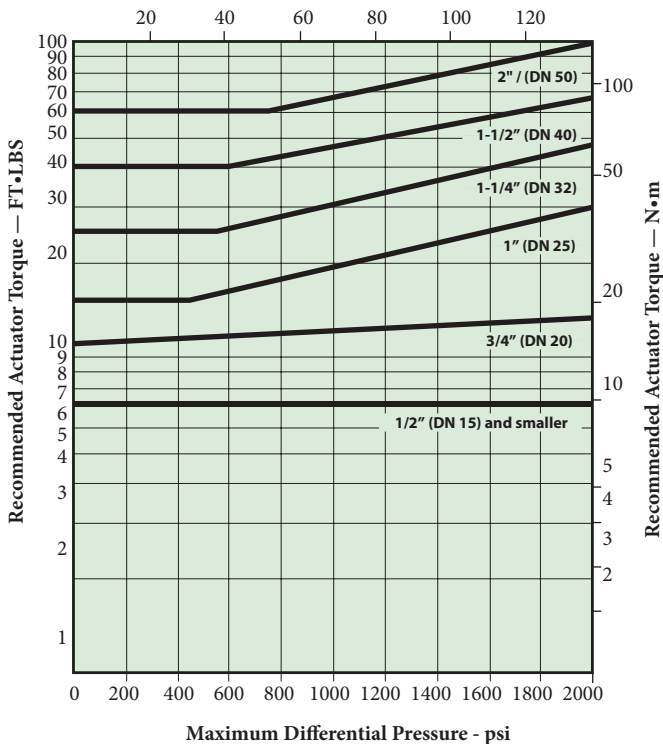

**PTFE (T) Seated Valves**

Maximum Differential Pressure - bar

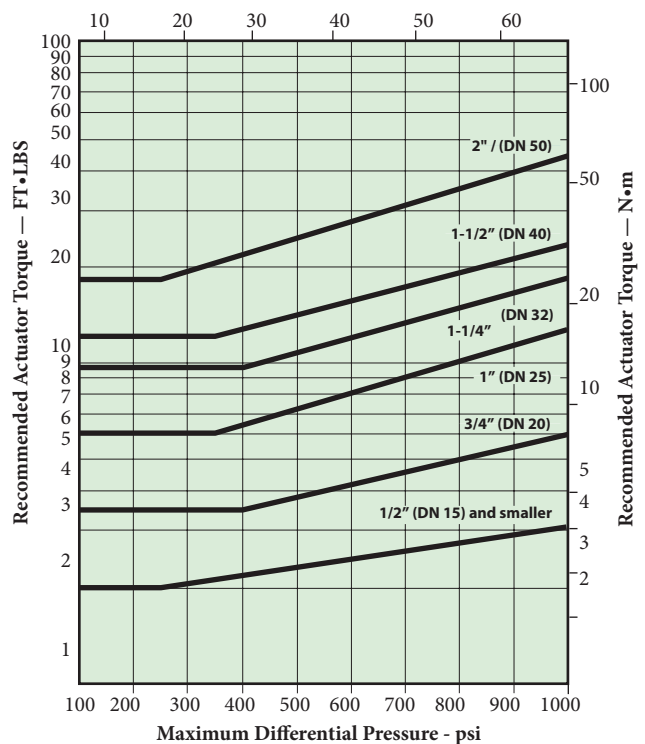

## Actuators

Valmet offers a full line of integrally designed actuators for automated systems or for easier control of inaccessible or remote valves. Pneumatic actuators that include double-acting and spring-return piston, vane and rack and pinion units, spring-diaphragm types, and electric actuators are available for all valves. Electric actuators are available in both watertight and hazardous location models.

For further information on actuators for A-Style valves, see the following:

Type	Bulletin
Spring Diaphragm Rotary Actuators	A110-4
Double Opposed Piston Actuators	A111-5
V-Series Electric Actuators	V200-1
ADC-Series Electric Actuators	V201-1
QX-Series Electric Actuators	V207-1
I-Series Electric Actuators	V206-1

## Flow Data

The table below provides flow coefficients of reduced port A-Style valves. The  $C_v$  values represent the flow of water at +60°F through the valve in gallons per minute at a pressure drop of 1 psi. The metric equivalent,  $K_v$ , is the flow of water at 16°C through the valve in cubic meters per hour at a pressure drop of 1kg/cm<sup>2</sup>. To convert  $C_v$  to  $K_v$  multiply by 0.8569.

Valve Size		$C_v$	Equivalent length of pipe - ft.
Inches	DN		
1/4	8	6	.33
3/8	10	10	.61
1/2	15	13	1.5
3/4	20	33	1.1
1	25	44	2.1
1-1/4	32	46	8.4
1-1/2	40	95	4.5
2	50	111	12.0

**WARNING:** As the use of the valve is application specific, a number of factors should be taken into account when selecting a valve for a given application. Therefore, some of the situations in which the valves are used are outside the scope of this manual. If you have any questions concerning the use, application, or compatibility of the valve with the intended service, contact Valmet for more information.

## HOW TO ORDER A-STYLE BALL VALVES

To specify a valve select the body style, the combination of body and trim material and the proper seat material for the application.

1	2	3	4	5	6	7	8
1-1/2	A	Z	—	22	36	XT	D

**Example:** This example is for a 1-1/2" Fire-Tite 2000 CWP NPT ball valve constructed of carbon steel body, stainless steel ball and stem, Xtreme seats, TFM seals and Model Code D

1	Valve Size	
	Inches	DN
1/4	1/4	8
3/8	3/8	10
1/2	1/2	15
3/4	3/4	20
1	1	25
1-1/4	1-1/4	32
1-1/2	1-1/2	40
2	2	50

2	Body Style
A	1/4 – 2" (DN 8 – 50)

3	Conformance
–	Non Fire-Tite
Z	Fire-Tite to API 607

4	Special Application/Construction or Service
–	Standard
O	Oxygen
C	Chlorine
V	High Vacuum
VC	High Vacuum Certified
TG	Top Ground
STGR	Top & Bottom Ground
W	Seal Welded

5	Body Material
22	Carbon Steel (WCB)
36	316 Stainless Steel (CF8M)

6	Ball & Stem Material
00	Same as Body (Carbon Steel not Available)
36	316 Stainless Steel (CF8M)
HB	316 SS Ball, 17-4PH Stem
71	Monel

7	Seat & Seal Material	
	Seats	Seal (Stem & Body)
Standard		
TT	PTFE	PTFE & Graphite & TFM
XT	Xtreme	TFM & Graphite & TFM
Non Fire-Tite Only		
RT**	Acetal	PTFE & TFM

8	Model Code
D	A-Style Model D (Not Required for Ordering)

\*\* Exclusively for Standard Construction. 17-4 PH stem required.  
Not a self-relieving seat design.

Monel® is a registered trademark of Inco  
TFM® is a registered trademark of Dyneon C

Subject to change without prior notice.  
Neles, Neles Easyflow, Jamesbury, Stonel, Valvcon and Flowrox, and certain other trademarks, are either registered trademarks or trademarks of Valmet Oyj or its subsidiaries in the United States and/or in other countries.

**Valmet Flow Control Oy**  
Vanha Porvoontie 229, 01380 Vantaa, Finland.  
Tel. +358 10 417 5000.  
[www.valmet.com/flowcontrol](http://www.valmet.com/flowcontrol)

