



TYPE R AUTOPILOT DRIVE UNIT SYSTEM PACKS



INSTALLATION MANUAL

OC15269 REV F 27 JULY 2012

Revision History

Revision	Description
E	Redesign in booklet format
F	See DCR # 0961

© 2012 Octopus Products Inc. All rights reserved.

The information contained in this document is the sole property of Octopus Products Inc. Any reproduction in part or whole without the written permission of Octopus Products Inc. is prohibited. Octopus Products Inc will nor be liable for errors contained herein or for incidental or consequential damages in connection with the furnishing, performance or use of this document.

CONTENTS

A	Introduction	
A1	System Overview	4
A2	Compatibility Information	4
A3	Important Safety Features	5
	A3a <i>Manual Release</i>	5
	A3b <i>Manual Override</i>	5
B	Mechanical Installation	
B1	Available Space - Physical Envelope & Orientation	6
	B1a <i>Drive Installation</i>	7
B2	Outboard Engined Boats	8
	B2a <i>Engine compatibility</i>	8
	B2b <i>Supplied Parts</i>	8
	B2c <i>Installation</i>	8
B3	Sterndrive Boats Mercruiser DHB 1994+	12
	B3a <i>Engine compatibility</i>	12
	B3b <i>Supplied Parts</i>	12
	B3c <i>Installation</i>	13
B4	Sterndrive Boats Volvo Gasoline & Diesel USA 1997 Onwards	16
	B4a <i>Engine compatibility</i>	16
	B4b <i>Supplied Parts</i>	16
	B4c <i>Installation</i>	17
B5	Sterndrive Boats Mercruiser Saginaw 1983-93	20
	B5a <i>Engine compatibility</i>	20
	B5b <i>Supplied Parts</i>	20
	B5c <i>Installation</i>	21
B6	Sterndrive Boats Volvo Diesel Europe	24
	B6a <i>Engine compatibility</i>	24
	B6b <i>Supplied Parts</i>	24
	B6c <i>Installation</i>	25
B7	Inboard Engined Boats & Sailboats	28
	B7a <i>Compatibility</i>	28
	B7b <i>Supplied Parts</i>	28
	B7c <i>Installation</i>	29
	B7d <i>Quick Release</i>	32
	B7e <i>Specification</i>	32
B8	Routing Steering Cable	33
	B8a <i>Cable Length Calculation</i>	33
B9	Connecting Steering Cable To Drive	34
B10	Rudder Feedback Unit (RFB) Installation & Calibration	35
	B10a <i>Universal RFB Setup</i>	35
	B10b <i>Calibration and Installation</i>	36
B11	Interference Evaluation (Outboard Engines Only)	37
C	Electrical Installation	
C1	Connecting Drive To Autopilot	38
C2	Rudder Feedback Unit	38
	C2a <i>Connection - non Simrad autopilots</i>	38
	C2b <i>Connection - Simrad autopilots</i>	39
D	Appendix	
D1	Accessories	40
D2	General Maintenance Guide	41

A INTRODUCTION

A1 System Overview

The Octopus Type R Remote Drive is a rotary mechanical autopilot drive system which makes it simple and economical to fit an autopilot on smaller powerboats with mechanical push-pull cable steering or small sailboats with a steering quadrant or tiller.

The type R drive unit incorporates a drive motor, solenoid clutch and integrated rudder feedback (RFB) capability. Its design means that the drive can be mounted in a convenient position, meaning it will fit a large number of boats which because of design constraints or size were not practical to have an autopilot fitted before.

The system uses a steering cable and connection kit which is fitted in addition to the existing manual steering cable for cable steered boats or directly to the steering quadrant for sailboats. This allows the system to be easily installed on most types of boat without having to interfere with the existing steering system. There are five Type R packs available which include the drive unit, 6ft (1.8m) steering cable and relevant connection kit:

Part Number	Type	Compatibility
MDRESYS-A*	Sterndrive	Mer cruiser 1994 onwards, Volvo Gasoline engines and Volvo Diesel engines USA 1997 onwards
MDRESYS-B	Sterndrive	Mer cruiser Saginaw 1983-93, Volvo Diesel engines Europe 1994 onwards
MDRESYS-C	Outboard	Yamaha 70hp+
MDRESYS-D	Outboard	Mercury, Mariner, Suzuki
MDRESYS-E	Inboard/Sailboat	Up to 32ft (9.75m) / 13,200lbs (6,000kg) displacement

* We recommend changing the steering cable for a 9ft version when installing on to a twin engine boat.

A2 Compatibility Information

- The Type R Remote Drive is recommended for use on vessels with a maximum speed of 44mph (65km/h) and should not be fitted to vessels which can exceed this.
- It should not be fitted to boats where the engine max horsepower exceeds the max horsepower rating for the vessel as stated on the vessel manufacturer's tag.
- The existing steering system MUST be capable of being back driven. The Type R Remote Drive cannot be fitted if the steering system is a NFB (no feed back) type.
- The drive is designed to produce a maximum cable push/pull of 300lbs (136kg), which makes it suitable for the vast majority of cable steered vessels. However some vessels fitted with push pull cable steering systems have very stiff steering or steering which is heavily loaded in one direction due to hull design and engine considerations. Generally speaking, the Type R drive will steer vessels that do not require more than a 15lb force on the rim of a 14in diameter steering wheel to hold a course, this equals 105in-lb of torque. If the steering wheel input torque exceeds this figure we would recommend that the vessel be fitted with a hydraulic linear actuator drive system instead.

A3 Important Safety Features

The Helmsperson should be made aware of the two following safety features before using the Autopilot:

A3a Manual Release

The drive features a manual release in case the Autopilot is switched to manual mode by mistake, which could result in a dangerous manoeuvre or violent movement of the steering wheel on a powerboat due to propeller action or trim forces.

While the drive is under consistent load from the boat's steering system in one direction or no movement, the drive unit clutch will remain engaged when the Autopilot is switched to manual mode.

To disengage the drive a small joggle action (turning the wheel/tiller from side to side) will release the clutch and allow manual control.

IMPORTANT The helmsperson should always be ready to take manual control of the boat when the Autopilot is returned to manual mode.

DOCKSIDE TESTING Due to the 'Manual Release' safety feature, when the vessel is not in motion it might be necessary to joggle the wheel/tiller (move from side to side) to engage or disengage the drive.

A3b Manual Override

IMPORTANT It is **STRONGLY** advised that the helmsperson be familiarized with this manual override procedure before proceeding to sea.

In the event of uncontrolled automatic steering or any other emergency situation where it is imperative that manual control be reassumed immediately, the helmsperson can override the steering action of the drive unit by exerting force on the steering wheel in the opposite direction to the drive. This action will cause the drive unit thrust limit to "slip" allowing the helmsperson to take control.

NOTE The manual override does not disengage the autopilot - to resume full manual control the autopilot should be switched to standby as soon as is practically possible.

B MECHANICAL INSTALLATION

B1 Available Space - Physical Envelope & Orientation

The selected installation site should provide adequate space to accommodate the drive unit including the entry and exit points for the steering cable. The drive can be mounted at any angle. Note that no access for maintenance purposes is required. The steering cable entry and exit ports are reversible, so the cable entry and exit ports can be selected for the best installation arrangement on the particular vessel.

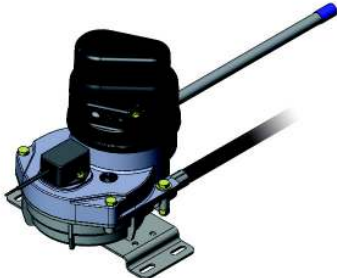

HORIZONTAL MOUNT

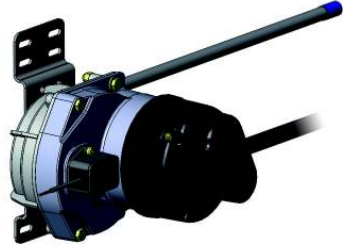

VERTICAL MOUNT

Fig B1 - Mounting options

NOTE If the ports are reversed, the steering action will also be reversed. This can be compensated for by adjusting the autopilot software or the drive motor wiring.

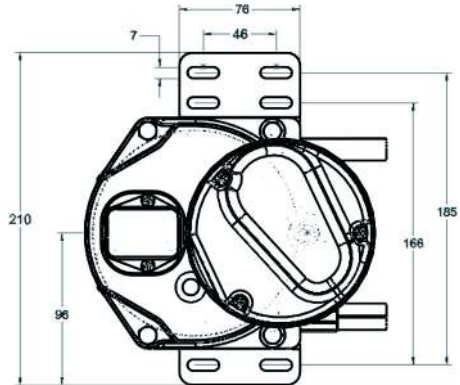
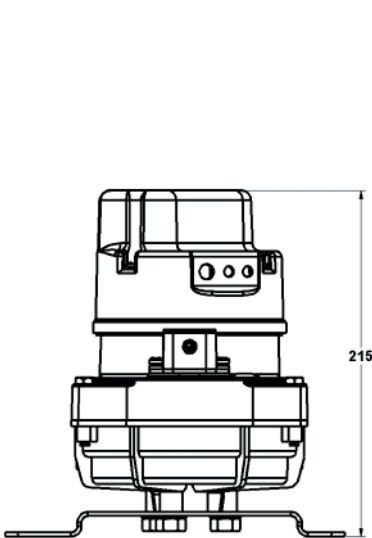

BASEPLATE PERPENDICULAR MOUNT

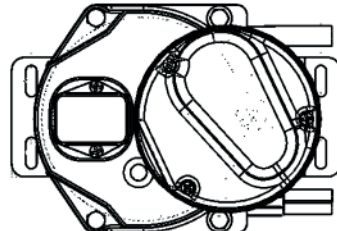

BASEPLATE PARALLEL MOUNT

Fig B2 - Physical drive envelope

B1a Drive Installation

The design of the Type R Autopilot Drive System gives a high degree of flexibility in the location of the drive unit relative to the steering mechanism, however factors such as the optimum steering cable route and also the length of the steering cable (6ft / 1.8m standard, other lengths available) will influence the final location.

It is recommended that the steering cable connection is the final stage of the mechanical installation, but it is advisable to take into account the points raised in section B8 regarding steering cable routing when planning the drive unit location.

- i) Position the drive unit in the final location. Verify that there is sufficient clearance for the steering cable entry and the spent cable tube, as well as access for the electrical connections.
- ii) Although there are no loads transferred to the drive unit mounting when the autopilot is in operation, the selected location should be sturdy enough to support the drive unit.
- iii) The drive base plate can be fitted in two possible orientations - perpendicular or parallel. Assemble the base plate to the drive using the most suitable orientation for the installation and torque the fasteners to 30-35in-lb (3.4-4.0Nm).
- iii) Mark out the fixing pattern from the drive base plate and drill appropriate sized pilot holes into the mounting structure (Fig B3). The mounting holes are suitable for $\frac{1}{4}$ in or 6mm fasteners.
- iv) Position the drive unit and install using suitable fasteners. Ensure they are tightened securely.

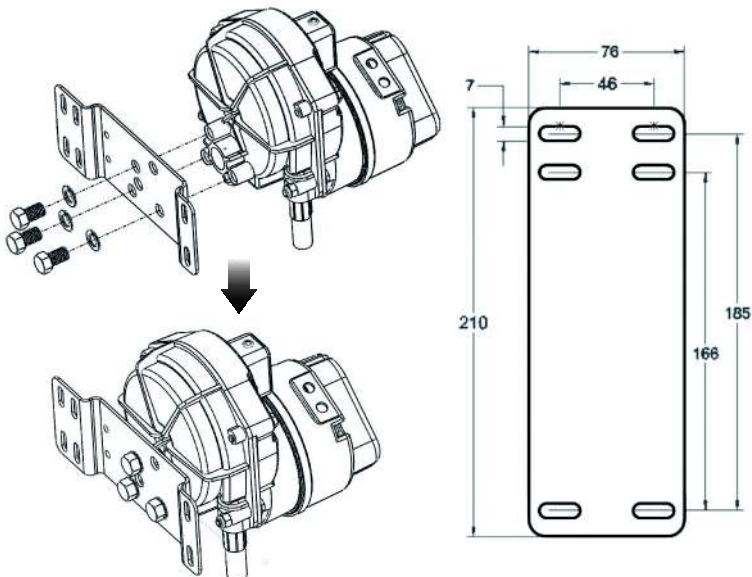

Fig B3 - Mounting plate drilling dimensions

B2 Outboard Engine Boats

The Outboard Installation Kits can be fitted to mechanical push-pull cable steered vessels that are powered by MOST of the popular Yamaha (MDRESYS-C) and Mercury/Mariner/Suzuki (MDRESYS-D) models of outboard engine. It is recommended for use on vessels with a maximum speed of 44mph and should NOT be fitted to vessels where the maximum horsepower of the engine exceeds the maximum horsepower rating for the vessel as stated on the vessel manufacturer's tag.

The installation kit allows the second steering cable for the Type R drive to be fitted to the outboard steering system.

B2a Engine Compatibility

The MDRESYS-C kit is suitable for use on Yamaha 115-220 HP produced from 1984 onwards. The Yamaha engine has M6 (metric system) threaded fittings.

The MDRESYS-D kit is suitable for use on Mercury Black Max outboards from 1980 onwards, Mariner outboards from 1980 onwards, Mercury/Mariner 2.4 (all models) and Suzuki DT75 – DT225 and DF60 – DF140. These engines have 1/8in-28 UNF threaded fittings.

B2b Supplied Parts

MDR-40	Type R Remote Rotary Autopilot Drive Unit
OC15SUK15A	Yamaha Outboard Installation Kit (MDRESYS-C) OR
OC15SUK15B	Mercury-Mariner-Suzuki Outboard Installation Kit (MDRESYS-D)
OC15109-6	6ft (1.8m) Secondary Steering Cable*

* Other lengths are available as optional accessories

B2c Installation

- Prepare the engine mounting site
 - i) Use the helm to centre the engine.
 - ii) Ensure that the area in front of the tilt tube is clear of obstructing wires, hoses etc. Reroute if necessary.
 - iii) There are four threaded holes on the front face of the tilt tube (Fig B4), ensure that these are free from paint etc - retap if necessary:

MDRESYS-C	M6 metric
MDRESYS-D	1/8in-28 UNF

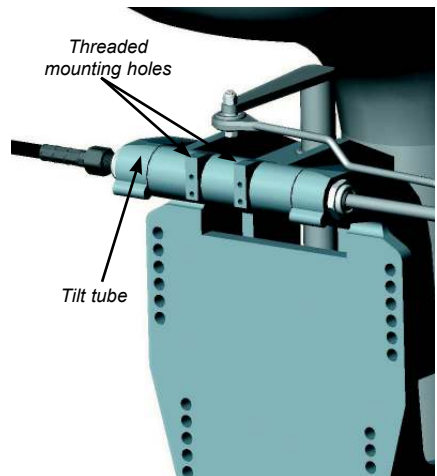

Fig B4 - Threaded mounting holes on front face of tilt tube

- Remove steering link arm
 - To simplify the re-assembly procedure, make a note of the connections between the steering link arm and the manual steering cable and engine tiller.
 - Disconnect the steering link arm from the manual steering cable and the engine tiller.
 - Retain the link arm and fixings etc for later use.

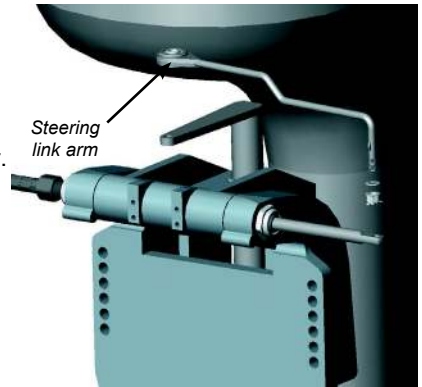

Fig B5 - Removing steering link arm

- Fit the secondary steering cable mount bracket to the engine tilt bracket
 - The bracket attaches to the four threaded mounting holes on the front face of the tilt tube (Fig B6). Four M6 $\frac{1}{4}$ in-28 UNF bolts and lockwashers are supplied in the kit.
 - Torque the bolts to 100in-lb (11Nm).

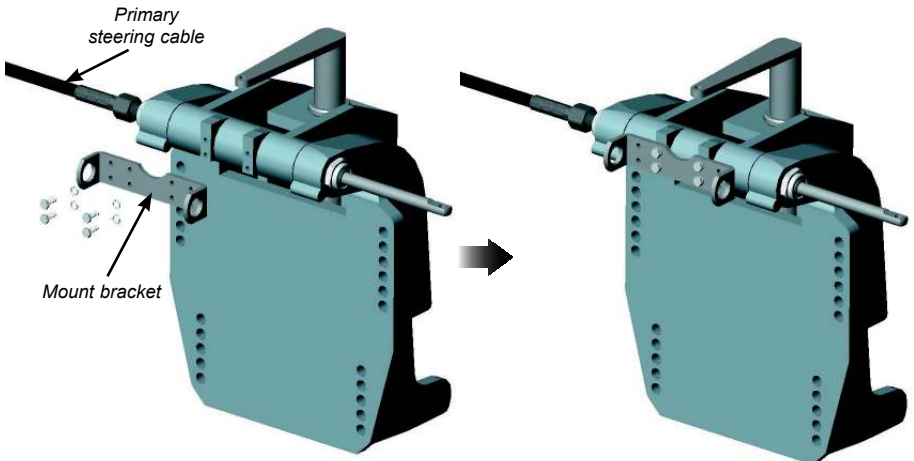

Fig B6 - Fitting the cable mount bracket

- Fit the cable guide tube to the cable mount bracket
 - i) Both the locknuts and the guide tube thread should be lubricated with marine quality grease before assembly.
 - ii) Slide the guide tube into the cable mount bracket as shown (Fig B7).

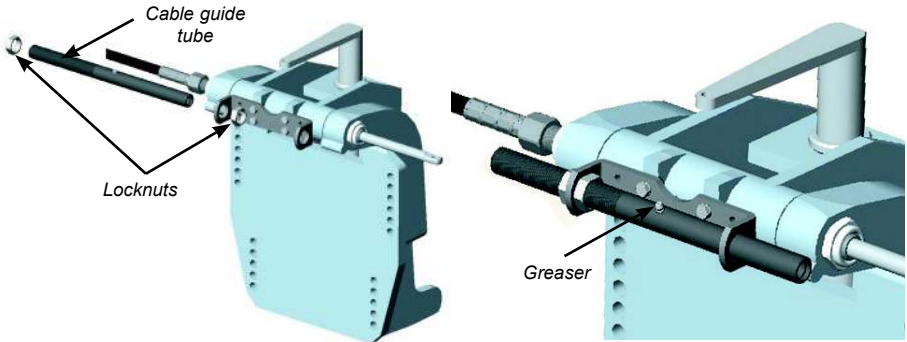

Fig B7 - Fitting the cable guide tube

- iii) Adjust the position of the guide tube so that the exit end of the guide tube aligns with the exit end of the engine tilt tube (Fig B8)
- iv) Tighten the two locknuts and torque to 175in-lb (20Nm). Grease the fitting.

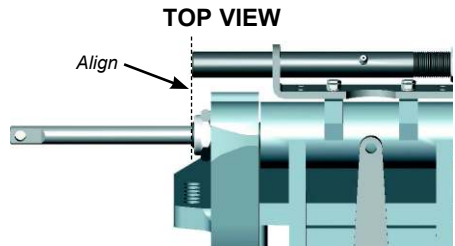

Fig B8 - Cable guide tube alignment

- Attach the secondary steering cable to the guide tube

- i) Both the cable nut, the guide tube thread and the inside of the guide tube should be liberally lubricated with marine quality grease before assembly.
- ii) Insert the rod end of the secondary steering cable into the threaded end of the guide tube (Fig B9).
- iii) Hand tighten the cable nut and torque to 175in-lb (20Nm). The nut has an internal locking thread which increases the amount of torque required initially as the thread is cut.

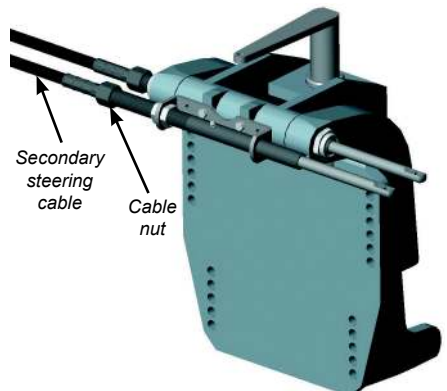

Fig B9 - Secondary steering cable

- Fit the dual block to the rod ends of the primary and secondary steering cables.
 - i) Disassemble the dual block assembly.
 - ii) Insert the two cable rod ends into the slots of the dual block.
 - iii) Align the crossholes and bolt through. The anti-vibration washers and nuts supplied must be fitted in the correct order with the serrated face of the washer in contact with the the nut face and the dual block face. The cam face of the washers must be in contact with each other (Fig B10).
 - iv) Torque the nuts to 180-200in-lb (20-22Nm).

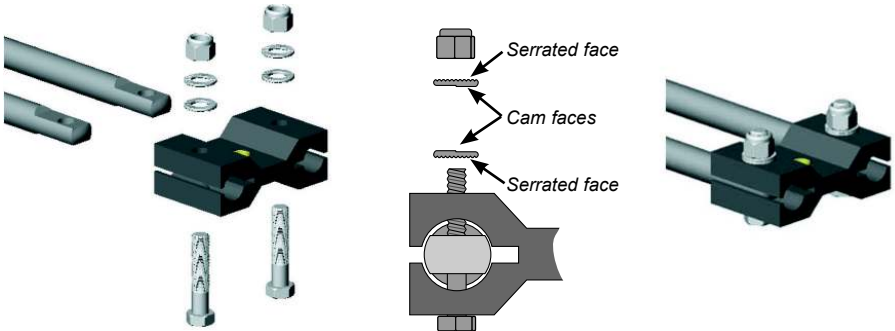

Fig B10 - Fitting dual block & correct washer orientation

- Reassemble the steering link arm.
 - i) Referring to the notes made when the steering was disassembled, reattach the steering link arm between the engine tiller and the dual block (Fig B11).

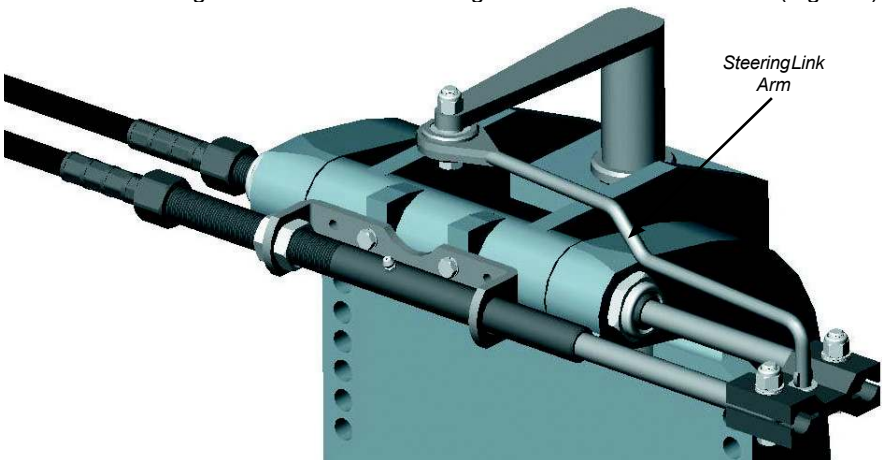

Fig B11 - Fitting the steering link arm

- Refer to section B9 on connecting the secondary steering cable to the drive unit.

B3 Sterndrive Boats Mercruiser DHB 1994+

The Octopus MDRESYS-A Type R Sterndrive pack can be fitted to mechanical push-pull cable controlled sterndrive power assisted steering cylinders made by Mercruiser (DHB).

The installation kit allows the second steering cable for the Type R drive to be fitted to the sterndrive steering system.

B3a Engine compatibility

Mercruiser DHB steering cylinders are fitted to Alpha One Generation II and Bravo Sterndrives from 1994 and newer.

B3b Supplied Parts

Type R	Remote Rotary Autopilot Drive Unit
OC15SUK12B	Sterndrive Installation Kit
OC15109-6	6ft (1.8m) Secondary Steering Cable
OC15109-9	9ft (2.75m) Secondary Steering Cable*

* Recommended for twin engine installations.

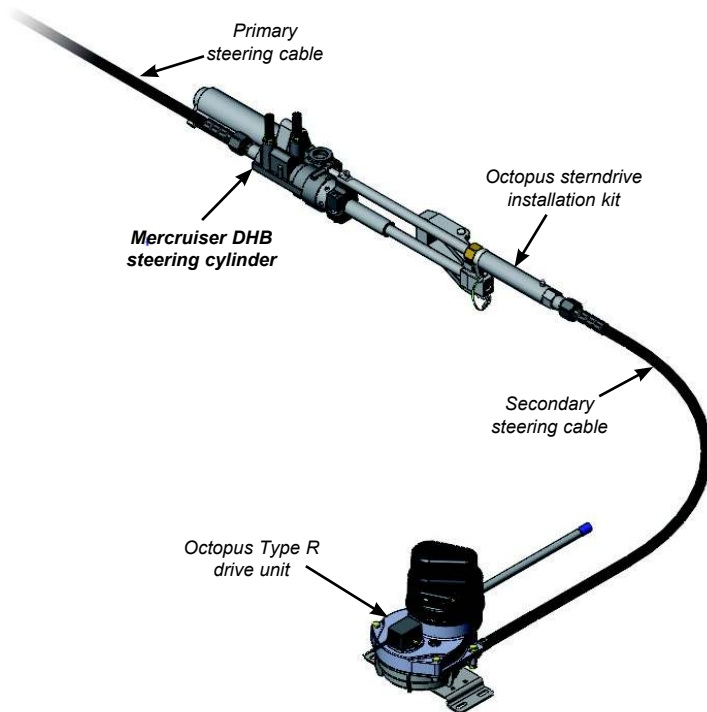

Fig B12 - Mercruiser DHB 1994+ cylinder installation configuration

B3c Installation

- Prepare the steering cylinder

- Use the helm to extend the steering cylinder to full hard over as shown in Fig B13 (it may be necessary to run the engine to do this).
- Remove the cotter and clevis pins that connect the primary steering cable rod end to the steering cylinder clevis bracket.
- Ensure that the flats on the steering cylinder are vertically aligned (it may be necessary to crack the nut on the primary steering cable to adjust this, the nut should then be re-torqued to 175in-lb / 20Nm).

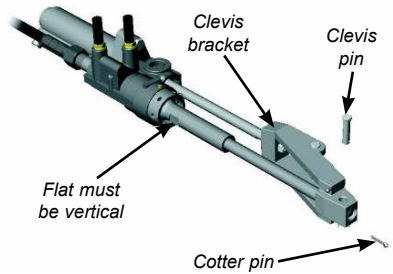

Fig B13 - Steering cylinder in fully extended position

- Fit the drive collar and spacer bush

- Use the helm to retract the primary steering cable to full opposite hard over so the rod end disengages from the cylinder clevis bracket (Fig B14a).
- Slacken the clamp screw and lock nut on the fitting kit drive collar.
- Fit the spacer bush on to the steering cylinder sleeve, ensure it is correctly oriented - refer to Fig B14b.
- Slide the drive collar on to the steering cylinder and over the spacer bush as shown in the diagram. *Do not tighten the clamp screw at this stage.*
- Use the helm to extend the primary steering cable back to full hard over so that the rod end re-engages into the cylinder clevis bracket.

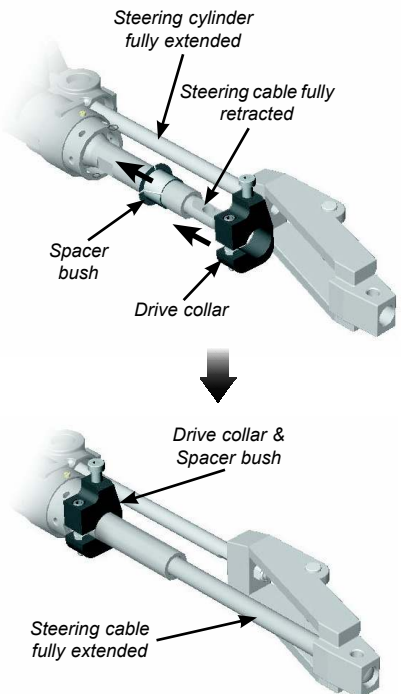

Fig B14 - Fitting the drive collar and bush to the steering cable sleeve

- Pre-fit the secondary steering cable to the guide tube/yoke assembly

- i) Both the cable nut, the guide tube thread and the inside of the guide tube should be liberally lubricated with marine quality grease before assembly.

- ii) Insert the rod end of the secondary steering cable into the threaded end of the guide tube (Fig B15).

- iii) Hand tighten the cable nut and torque to 175in-lb (20Nm)*. Note that the nut has an internal locking thread which increases the amount of torque required initially as the thread is cut.

- * There should be NO movement between the outer cable jacket and the guide tube when the nut is fully tightened.

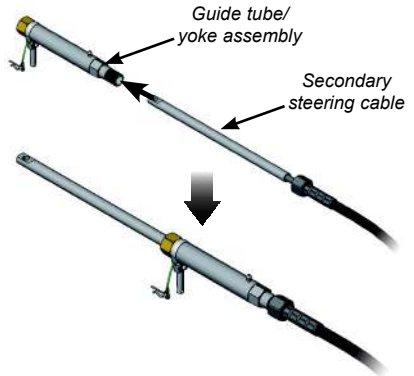

Fig B15 - Fitting the secondary steering cable to the guide tube

- Mount the connection kit and secondary steering cable to the steering cylinder.

This stage of the assembly will be easier if the Type R drive unit is not connected to the secondary steering cable at this point, as fine adjustments to the drive collar positioning are necessary and the backdrive friction from the drive unit will make this more difficult. Connecting the drive unit should be the final stage of the mechanical assembly.

- i) Remove the shoulder screw from the drive collar.

- ii) Position the connection kit assembly above the steering cylinder and engage onto the steering cylinder clevis bracket and drive collar as shown (Fig B16). Ensure that the clevis pin is also locking the primary steering cable rod end into the clevis bracket*.

- * If the clevis pin does not engage due to misalignment, adjust the manual steering helm slightly until the hole in the primary steering cable rod end aligns with the holes in the clevis bracket.

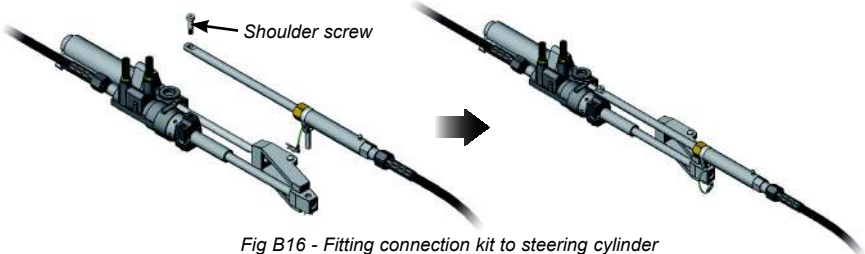

Fig B16 - Fitting connection kit to steering cylinder

- iii) Adjust the position of the drive collar so that the shoulder screw hole aligns with the hole in the secondary steering cable rod end.

- iv) Fit the shoulder screw, torque to 55in-lb (6nm). The screw has a locking thread which increases the amount of torque required initially as the thread is cut.

- v) Use the manual helm to set the steering to the midstroke position. Adjust the position of the drive collar so that there is a 7.4in (188mm) gap between it and the front face of the steering cylinder (Fig B17). Tighten the drive collar clamp screw and torque to 175in-lb (19Nm). Tighten the drive collar lock nut and torque to 45in-lb (5nm).

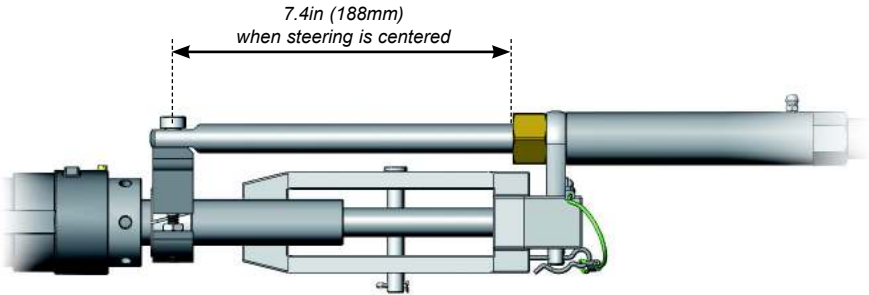

Fig B17 - Positioning the drive collar

- Refer to section B9 on connecting the steering cable to the drive unit

B4 Sterndrive Boats Volvo Gasoline & Diesel USA 1997 Onwards

The Octopus MDRESYS-A Type R Sterndrive pack can be fitted to mechanical push-pull cable controlled sterndrive power assisted steering cylinders made by Volvo for Gasoline engines and also Diesel engines in the USA since 1997.

The installation kit allows the second steering cable for the Type R drive to be fitted to the sterndrive steering system.

B4a Engine compatibility

The installation kit supplied is compatible with Volvo 3860883, 3860726, 3862210, 3862513, 3860882, 3862456 and 3862514 steering cylinders.

B4b Supplied Parts

Type R	Remote Rotary Autopilot Drive Unit
OC15SUK12B	Sterndrive Installation Kit
OC15109-6	6ft (1.8m) Secondary Steering Cable*
OC15109-9	9ft (2.75m) Secondary Steering Cable*

* Recommended for twin engine installations.

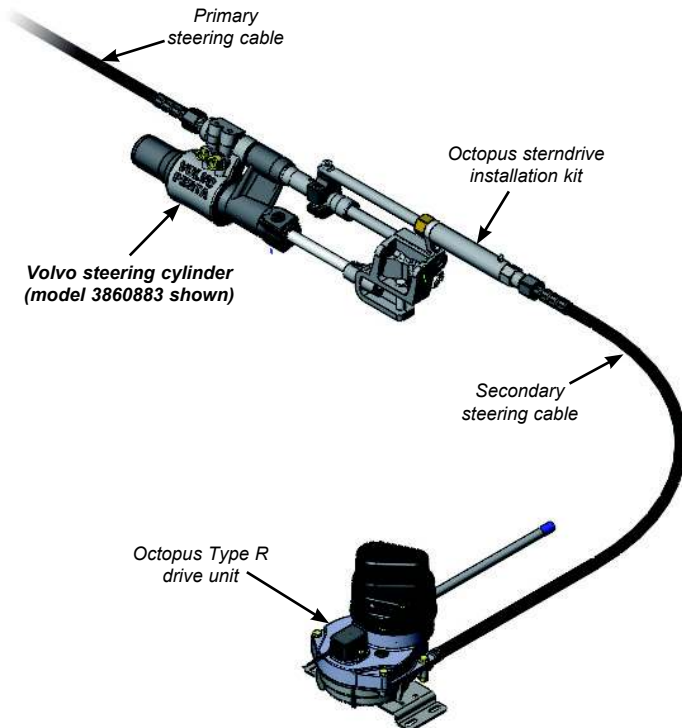

Fig B12 - Mercuriser DHB 1994+ cylinder installation configuration

B4c Installation

- Prepare the steering cylinder

- Use the helm to extend the steering cylinder to full hard over as shown in Fig B19 (it may be necessary to run the engine to do this).
- Remove the cotter and clevis pins that connect the primary steering cable rod end to the steering cylinder clevis bracket.

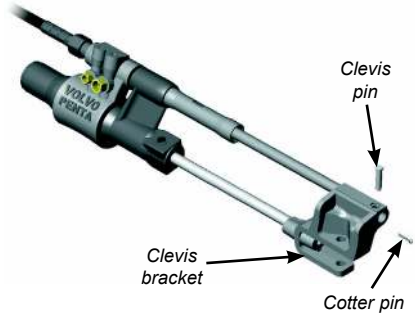

Fig B19 - Steering cylinder in fully extended position

- Fit the drive collar and spacer bush

- Use the helm to retract the primary steering cable to full opposite hard over so the rod end disengages from the cylinder clevis bracket (Fig B20a).
- Slacken the clamp screw and lock nut on the fitting kit drive collar.
- Fit the spacer bush* on to the steering cylinder sleeve, ensure it is correctly oriented - refer to Fig B20b.

* The spacer bush is not required on Volvo models 3862513 and 3862514 which were fitted from Sept 2003 onwards - the drive collar will clamp directly onto the cable guide tube.

- Slide the drive collar on to the steering cylinder and over the spacer bush as shown in the diagram. **Do not tighten the clamp screw at this stage.**
- Use the helm to extend the primary steering cable back to full hard over so that the rod end re-engages into the cylinder clevis bracket.

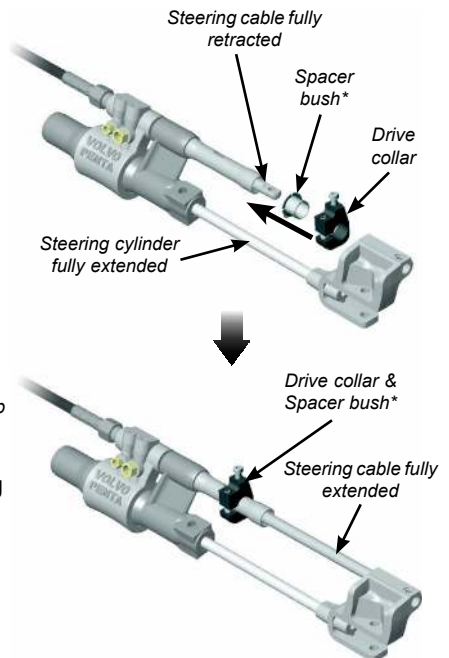

Fig B20 - Fitting the drive collar and bush to the steering cable sleeve

- Pre-fit the secondary steering cable to the guide tube/yoke assembly

- i) Both the cable nut, the guide tube thread and the inside of the guide tube should be liberally lubricated with marine quality grease before assembly.

- ii) Insert the rod end of the secondary steering cable into the threaded end of the guide tube (Fig B21).

- iii) Hand tighten the cable nut and torque to 175in-lb (20Nm)*. Note that the nut has an internal locking thread which increases the amount of torque required initially as the thread is cut.

- * There should be NO movement between the outer cable jacket and the guide tube when the nut is fully tightened.

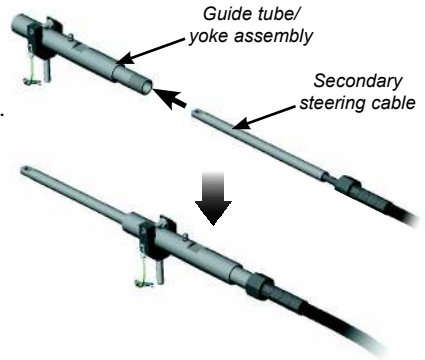

Fig B21 - Fitting the secondary steering cable to the guide tube

- Mount the connection kit and secondary steering cable to the steering cylinder.

This stage of the assembly will be easier if the Type R drive unit is not connected to the secondary steering cable at this point, as fine adjustments to the drive collar positioning are necessary and the backdrive friction from the drive unit will make this more difficult. Connecting the drive unit should be the final stage of the mechanical assembly.

- i) Remove the shoulder screw from the drive collar.

- ii) Position the connection kit assembly above the steering cylinder and engage onto the steering cylinder clevis bracket and drive collar as shown (Fig B22). Ensure that the clevis pin is also locking the primary steering cable rod end into the clevis bracket*. Lock in place using the hitch pin.

- * If the clevis pin does not engage due to misalignment, adjust the manual steering helm slightly until the hole in the primary steering cable rod end aligns with the holes in the clevis bracket.

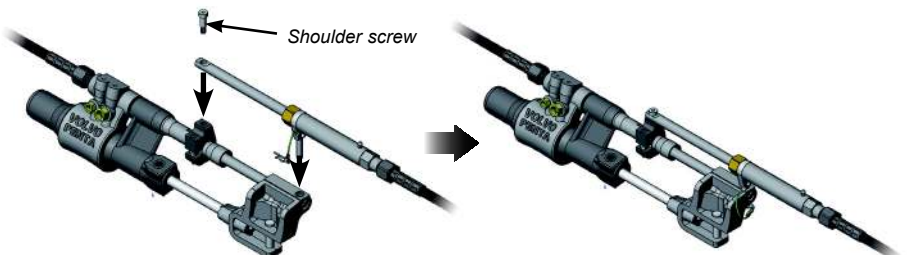
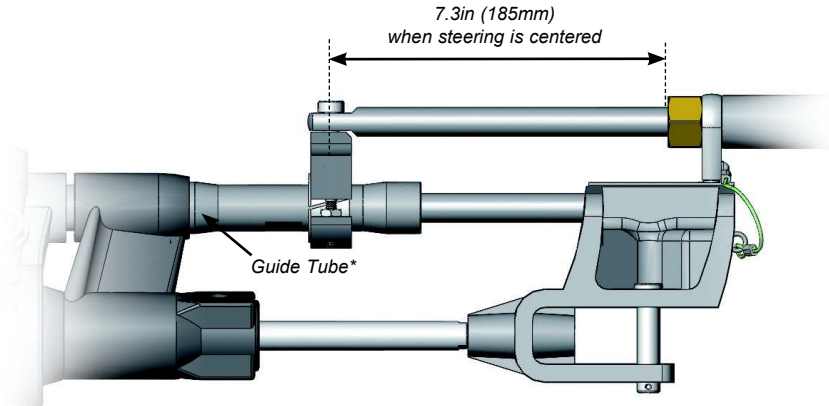

Fig B22 - Fitting connection kit to steering cylinder

- iii) Adjust the position of the drive collar so that the shoulder screw hole aligns with the hole in the secondary steering cable rod end.

- iv) Fit the shoulder screw, torque to 55in-lb (6nm). The screw has a locking thread which increases the amount of torque required initially as the thread is cut.

- v) Use the manual helm to set the steering to the midstroke position. Adjust the position of the drive collar so that there is a 7.3in (185mm) gap between it and the front face of the steering cylinder (Fig B23). Tighten the drive collar clamp screw and torque to 175in-lb (19Nm). Tighten the drive collar lock nut and torque to 45in-lb (5nm).



* This diagram shows the earlier model Volvo cylinders, which featured a "necked" guide tube - later models have a simpler parallel guide tube, which does not require the use of the Drive Collar Spacer Bush.

Fig B23 - Positioning the drive collar

- Refer to section B9 on connecting the secondary steering cable to the drive unit.

B5 Sterndrive Boats Mercruiser Saginaw 1983-93

The Octopus MDRESYS-B Type R Sterndrive pack can be fitted to mechanical push-pull cable controlled sterndrive power assisted steering cylinders fitted to Mercruiser Alpha One Generation II and Bravo Sterndrives between 1983 and 1993 (Saginaw).

The installation kit allows the second steering cable for the Type R drive to be fitted to the sterndrive steering system.

B5a Engine compatibility

Mercruiser Saginaw steering cylinders are fitted to Alpha One Generation II and Bravo Sterndrives from 1983 to 1993.

B5b Supplied Parts

Type R	Remote Rotary Autopilot Drive Unit
OC15SUK12C	Sterndrive Installation Kit
OC15109-6	6ft (1.8m) Secondary Steering Cable*

** Other lengths are available as optional accessories*

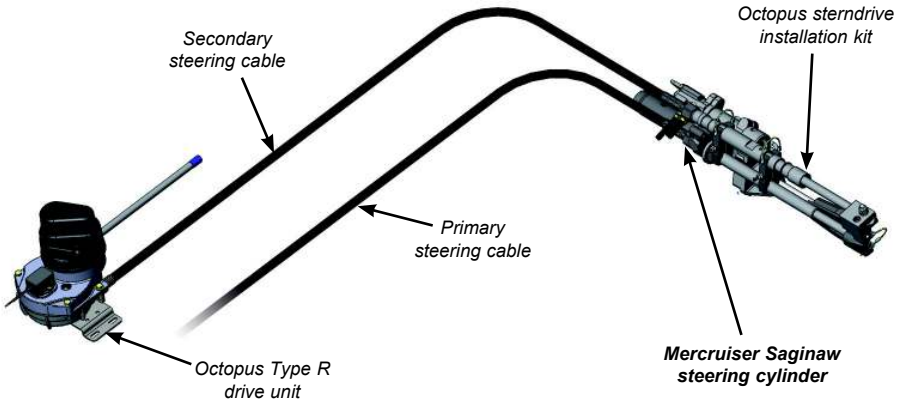

Fig B24 - Mercruiser Saginaw 1983-93 cylinder installation configuration

B5c Installation

- Prepare the steering cylinder
 - Use manual helm to set the steering cylinder to the mid stroke position as shown in Fig B25 (it may be necessary to run the engine to do this).
 - Remove the cotter and clevis pins that connect the primary steering cable rod end to the steering cylinder clevis bracket.

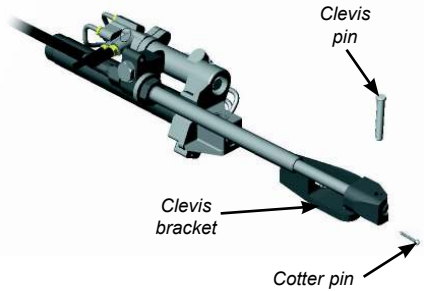

Fig B25 - Steering cylinder in mid stroke position

- Fit the secondary steering cable to the guide tube

- The cable nut, guide tube thread and inside of the guide tube should be liberally lubricated with marine quality grease before assembly.
- Insert the rod end of the secondary steering cable into the threaded end of the guide tube (Fig B26).
- Hand tighten the cable nut and torque to 175in-lb (20Nm)*. Note that the nut has an internal locking thread which increases the amount of torque required initially as the thread is cut.

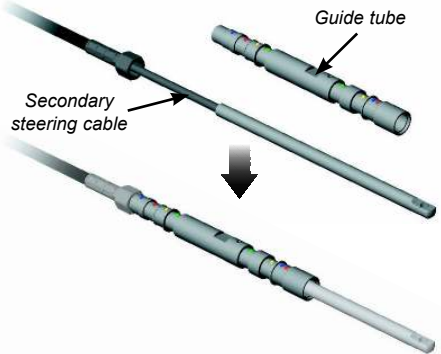

Fig B26 - Fitting the secondary steering cable to the guide tube

* There should be NO movement between the outer cable jacket and the guide tube when the nut is fully tightened.

- Fit the two clamp assemblies to the guide tube and cable assembly

- The anti-vibration washers must be fitted in the correct order on the clamp assemblies, with the serrated face of the washer in contact with the nut face and the clamp face. The cam face of the washers must be in contact with each other (Fig B27).
- Slacken the nuts enough so that the clamps can slide over the guide tube. Locate the clamps in the GREEN color coded slots as shown. Do not tighten the nuts at this stage.

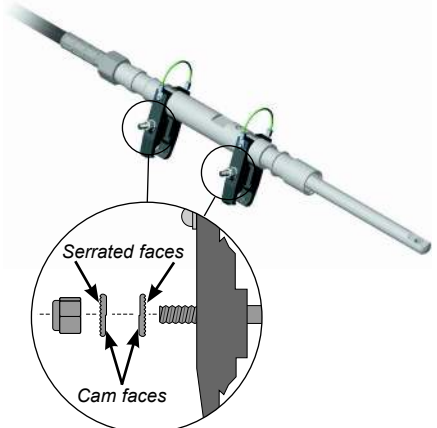

Fig B27 - Fitting the clamp assemblies

• Fit the clevis block to the secondary steering cable rod end

- i) Remove the hitch pin from the clevis block pin.
- ii) Remove the nut, 2 x anti-vibration washers and bolt from the clevis block.
- iii) Insert the cable rod end into the slotted hole in the clevis block. Ensure the clevis block is correctly oriented as shown, with the clevis pin pointing down (Fig B28).
- iv) Fit the bolt through the bottom of the clevis block, through the cable rod end and out the top of the block. Fit the anti-vibration washers in the correct order, with the serrated face of the washer in contact with the the nut face and the clevis block face. The cam face of the washers must be in contact with each other.
- v) Tighten the locking nut and torque to 180-200in-lb (20-22.5Nm). The screw has a locking thread which increases the amount of torque required initially as the thread is cut.

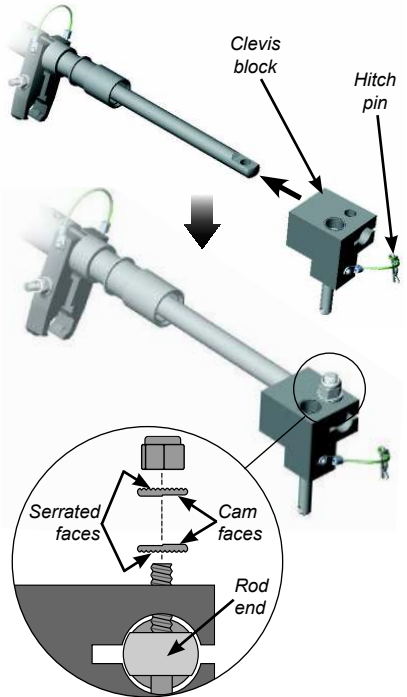

Fig B28 - Fitting the clevis block to the secondary cable rod end

- Mount the connection kit and secondary steering cable to the steering cylinder.

This stage of the assembly will be easier if the Type R drive unit is not connected to the secondary steering cable at this point, as fine adjustments to the drive collar positioning are necessary and the backdrive friction from the drive unit will make this more difficult. Connecting the drive unit should be the final stage of the mechanical assembly.

- i) Position the connection kit assembly above the steering cylinder as shown (Fig B29). Hold the two clamp assemblies open so they will fit over the manual steering cable guide tube, at the same time ensure that both clamps remain engaged in the GREEN color coded slots of the secondary cable guide tube.

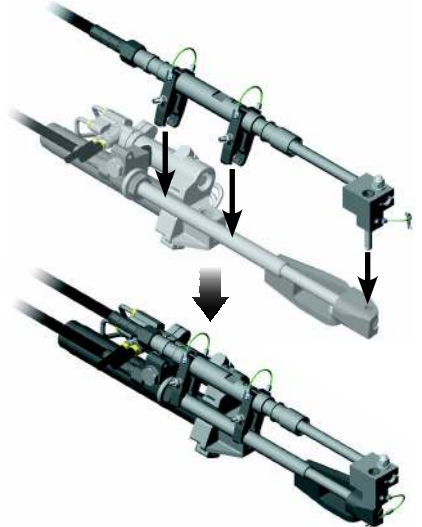

Fig B29 - Fitting connection kit to steering cylinder

- ii) Lower the connection kit assembly onto the cylinder and clevis bracket as shown. Ensure that the clevis pin is also locking the primary steering cable rod end into the clevis bracket*. Lock in place using the hitch pin.

** If the clevis pin does not engage due to misalignment, adjust the manual steering helm slightly until the hole in the primary steering cable rod end aligns with the holes in the clevis bracket.*

- iii) Position the connection kit so that there is a minimal gap between the rear clamp assembly and the primary steering cable guide tube lock nut (Fig B30). Tighten the nuts on both clamp assemblies and torque to 100in-lb (11nm).

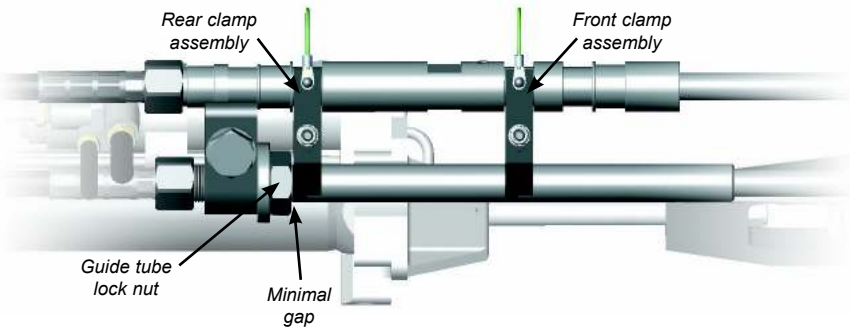

Fig B30 - Positioning the connection kit

- Refer to section B9 on connecting the secondary steering cable to the drive unit.

B6 Sterndrive Boats Volvo Diesel Europe

The Octopus MDRESYS-B Type R Sterndrive pack can be fitted to mechanical push-pull cable controlled sterndrive power assisted steering cylinders made by Volvo for Diesel engines in Europe.

The installation kit allows the second steering cable for the Type R drive to be fitted to the sterndrive steering system.

B6a Engine compatibility

Volvo Diesel engines fitted with model 872215 sterndrive power assisted steering cylinders.

B6b Supplied Parts

Type R	Remote Rotary Autopilot Drive Unit
OC15SUK12C	Sterndrive Installation Kit
OC15109-6	6ft (1.8m) Secondary Steering Cable*

* Other lengths are available as optional accessories

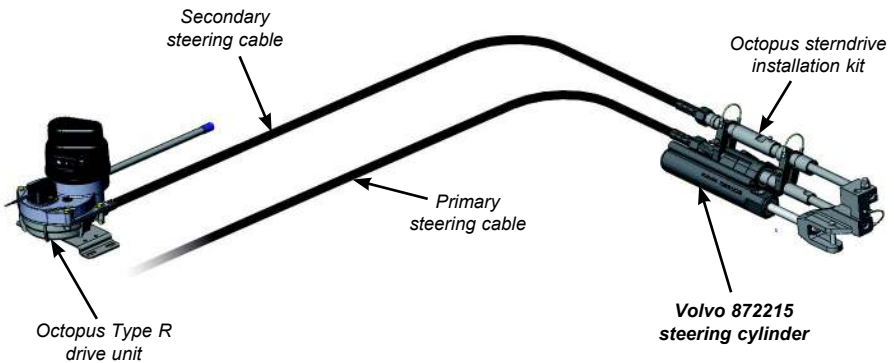

Fig B31 - Volvo Diesel (Europe) cylinder installation configuration

B6c Installation

- Prepare the steering cylinder
 - i) Use manual helm to set the steering cylinder to the mid stroke position as shown in Fig B32 (it may be necessary to run the engine to do this).
 - ii) Remove the cotter and clevis pins that connect the primary steering cable rod end to the steering cylinder clevis bracket.

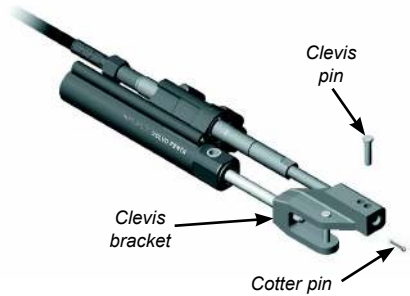

Fig B32 - Steering cylinder in mid stroke position

- Fit the secondary steering cable to the guide tube

- i) The cable nut, guide tube thread and inside of the guide tube should be liberally lubricated with marine quality grease before assembly.
- ii) Insert the rod end of the secondary steering cable into the threaded end of the guide tube (Fig B33).
- iii) Hand tighten the cable nut and torque to 175in-lb (20Nm)*. Note that the nut has an internal locking thread which increases the amount of torque required initially as the thread is cut.

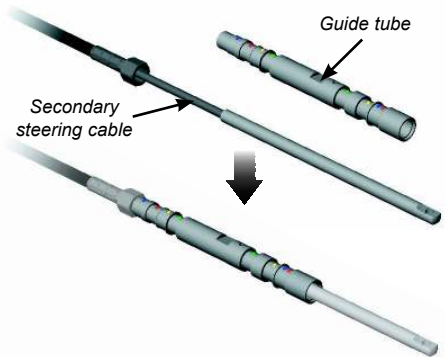

Fig B33 - Fitting the secondary steering cable to the guide tube

* There should be NO movement between the outer cable jacket and the guide tube when the nut is fully tightened.

- Fit the two clamp assemblies to the guide tube and cable assembly

- i) The anti-vibration washers must be fitted in the correct order on the clamp assemblies, with the serrated face of the washer in contact with the nut face and the clamp face. The cam face of the washers must be in contact with each other (Fig B34).
- iv) Slacken the nuts enough so that the clamps can slide over the guide tube. Locate the clamps in the YELLOW color coded slots as shown. Do not tighten the nuts at this stage.

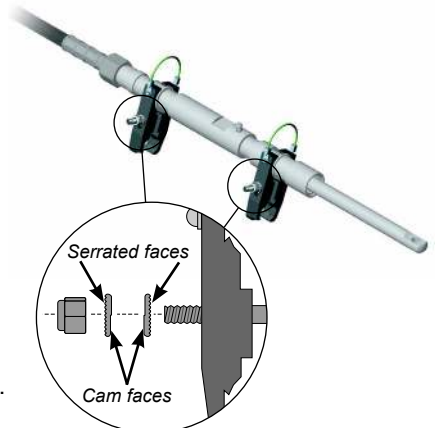

Fig B34 - Fitting the clamp assemblies

• Fit the clevis block to the secondary steering cable rod end

- i) Remove the hitch pin from the clevis block pin.
- ii) Remove the nut, 2 x anti-vibration washers and bolt from the clevis block.
- iii) Insert the cable rod end into the slotted hole in the clevis block. Ensure the clevis block is correctly oriented as shown, with the clevis pin pointing down (Fig B35).
- iv) Fit the bolt through the bottom of the clevis block, through the cable rod end and out the top of the block. Fit the anti-vibration washers in the correct order, with the serrated face of the washer in contact with the the nut face and the clevis block face. The cam face of the washers must be in contact with each other.
- v) Tighten the locking nut and torque to 180-200in-lb (20-22.5Nm). The screw has a locking thread which increases the amount of torque required initially as the thread is cut.

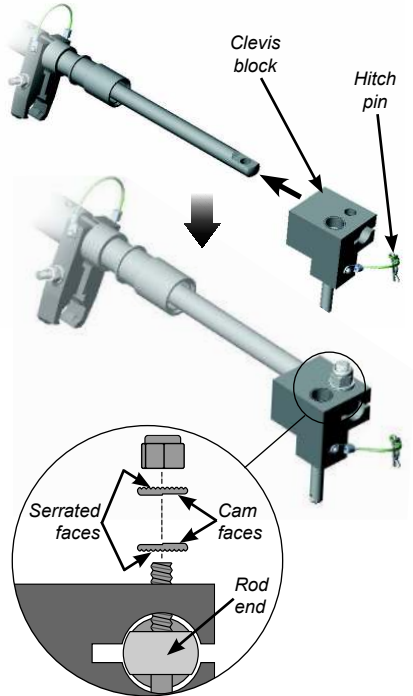

Fig B35 - Fitting the clevis block to the secondary cable rod end

- Mount the connection kit and secondary steering cable to the steering cylinder.

This stage of the assembly will be easier if the Type R drive unit is not connected to the secondary steering cable at this point, as fine adjustments to the drive collar positioning are necessary and the backdrive friction from the drive unit will make this more difficult. Connecting the drive unit should be the final stage of the mechanical assembly.

- Position the connection kit assembly above the steering cylinder as shown (Fig B36). Hold the two clamp assemblies open so they will fit over the manual steering cable guide tube, at the same time ensure that both clamps remain engaged in the YELLOW color coded slots of the secondary cable guide tube.
- Lower the connection kit assembly onto the cylinder and clevis bracket as shown. Ensure that the clevis pin is also locking the primary steering cable rod end into the clevis bracket*. Lock in place using the hitch pin.

** If the clevis pin does not engage due to misalignment, adjust the manual steering helm slightly until the hole in the primary steering cable rod end aligns with the holes in the clevis bracket.*

- Position the connection kit so that the primary and secondary steering cable nuts are aligned (Fig B38). Tighten the nuts on both clamp assemblies and torque to 100in-lb (11nm).

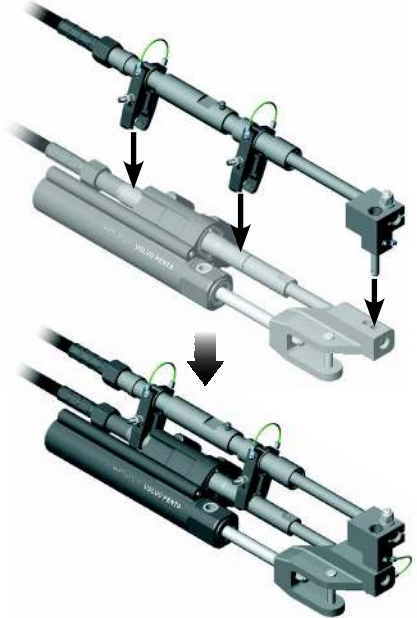

Fig B36 - Fitting connection kit to steering cylinder

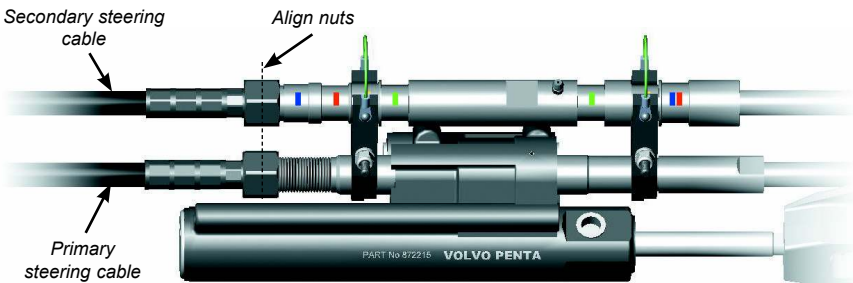

Fig B37 - Positioning the connection kit

- Refer to section B9 on connecting the secondary steering cable to the drive unit.

B7 Inboard Engine Boats & Sailboats

The Universal Inboard Installation Kit can be fitted to mechanically steered inboard engine boats with access to a quadrant or tiller or smaller sailboats. It is recommended for use on vessels with a maximum speed of 44 mph.

The installation kit allows the second steering cable for the Type R drive to be fitted to the boat's steering quadrant or tiller.

B7a Compatibility

The MDRESYS-E kit is suitable for use on most sailboats and power boats with mechanical steering less than 32ft (9.75m) in length and with a displacement of not more than 13,200lbs (6,000Kg).

In all cases, the primary steering system must be capable of being back-driven with a torque of less than 105in-lb (12Nm). If the amount of force required to maintain course is greater than this, then the Type R drive is not suitable.

B7b Supplied Parts

Type R	Remote Rotary Autopilot Drive Unit
OC15SUK19	Universal Inboard Installation Kit
OC15109-6	6ft (1.8m) Secondary Steering Cable
OC15109-9	9ft (2.75m) Secondary Steering Cable*

* Recommended for twin engine/rudder installations.

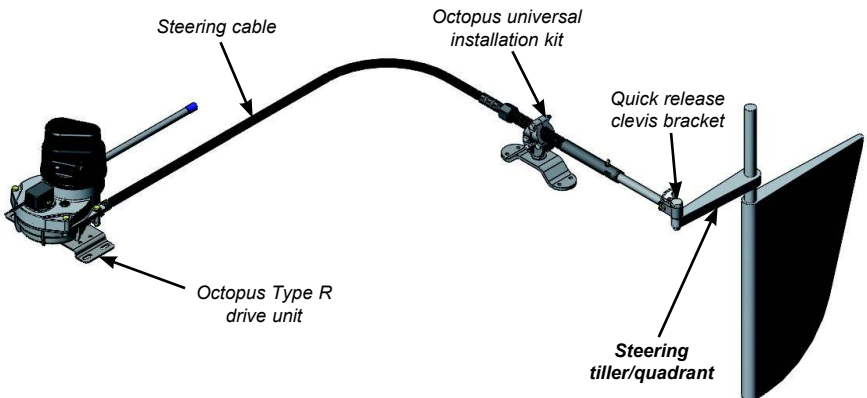

Fig B38 - Inboard installation configuration

B7c Installation

- Determine the mounting position of the installation kit (Fig B39)

This stage of the assembly will be easier if the Type R drive unit is not connected to the secondary steering cable at this point, as fine adjustments to the drive collar positioning are necessary and the backdrive friction from the drive unit will make this more difficult. Connecting the drive unit should be the final stage of the mechanical assembly.

- i) The kit must be mounted to a secure and stable surface that will be able to withstand the forces generated by the drive and the rudder.

- ii) The kit has an 8.5in (216mm) stroke and will need to be located so that the rudder is at a 35° angle when in the hard over position. This means the steering cable attachment point will typically be approx 7.4in (188mm) from the rudder stock. Any further from the rudder stock will reduce the amount of rudder angle which the drive can apply, which may adversely affect the responsiveness of the autopilot. Moving the mounting point closer to the rudder stock will increase the amount of force required to move the rudder which may slow the lock-to-lock time of the autopilot.

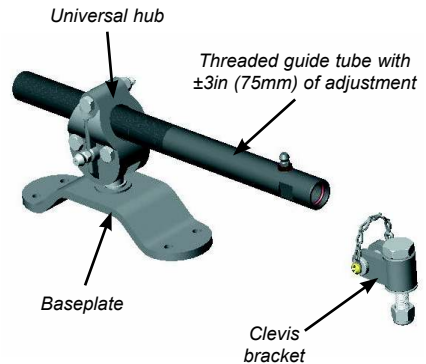
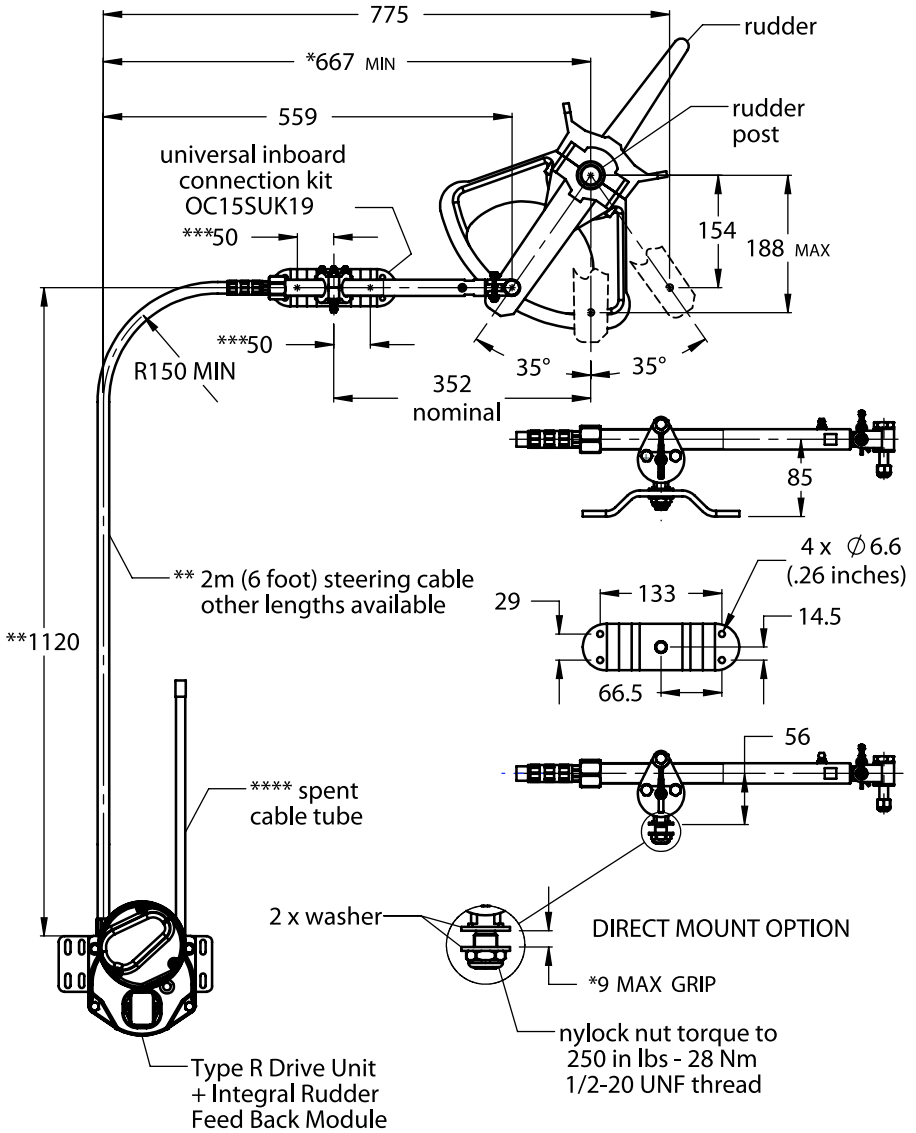

Fig B39 - Universal installation kit

- iii) The kit features a universal hub which offers 360° freedom of movement in the horizontal plane and ±40° in the vertical plane. It can be mounted in any orientation provided the kit is not forced beyond its rotational limits at any point across the full steering range of the boat.
- iv) The threaded guide tube offers up to ±3in (75mm) of lateral adjustment.
- v) Ideally, the kit should be located so that the thrust from the steering cable is perpendicular (ie at 90°) to the tiller at the mid-stroke position.
- vi) The kit can be mounted with or without the base plate supplied.
- vii) The clevis bracket can be mounted directly to the quadrant, or to a separate tiller arm. An 0.375in (9.5mm) diameter hole will need to be drilled through the tiller in order to attach the shoulder bolt supplied with the clevis bracket.
- viii) Refer to the installation envelope diagram (Fig B40 overleaf) to ascertain the best position for the kit.



- * Min Space Required
- ** Based on 2m Steering Cable
- *** Adjustment Range
- **** entry point of Steering Cable & Spent Cable Tube are Reversible

Fig B40 - Inboard kit installation envelope

- Fit the clevis bracket to the tiller/quadrant
 - i) Use manual helm to set the rudder to the centerline position.
 - ii) Using the information from the installation envelope diagram, drill an 0.375in (9.5mm) diameter hole through the tiller/quadrant at a distance of 6in (152mm) from the rudder stock*.
** The clevis bracket can be mounted to a separate tiller arm if a suitable location is not available on the tiller/quadrant*
 - ii) Fit the clevis bracket to the tiller as shown in Fig B41, ensuring that the plastic bushes, bracket, washer etc are fitted in the correct order.
 - iii) Tighten the locking nut and torque to 180-200in-lb (20-22.5Nm). The screw has a locking thread which increases the amount of torque required initially as the thread is cut.
 - iv) Remove the quick release locking pin from the bracket.

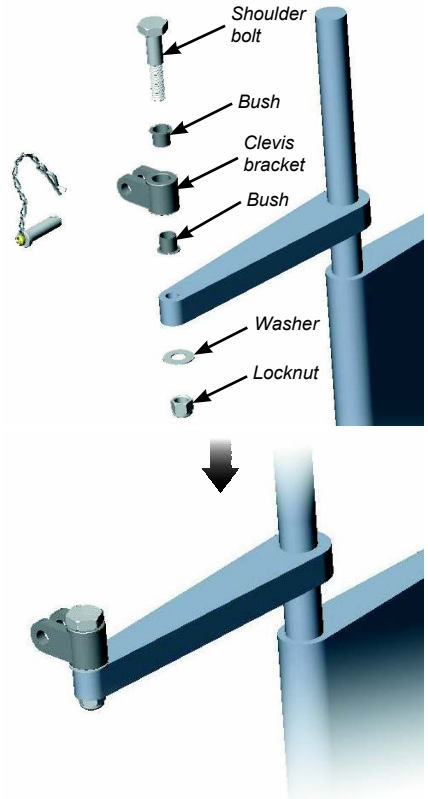

Fig B41 - Fitting the clevis bracket to the tiller

- Fit the steering cable to the guide tube
 - i) The cable nut, guide tube thread and inside of the guide tube should be liberally lubricated with marine quality grease before assembly.
 - ii) Insert the rod end of the steering cable into the threaded end of the guide tube (Fig B42).
 - iii) Hand tighten the cable nut and torque to 175in-lb (20Nm)*. Note that the nut has an internal locking thread which increases the amount of torque required initially as the thread is cut.
** There should be NO movement between the outer cable jacket and the guide tube when the nut is fully tightened.*

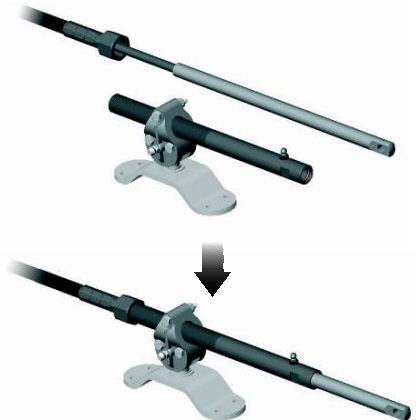

Fig B42 - Fitting the steering cable to the drive tube

- Attach the steering cable to the tiller
 - i) Rotate the steering cable rod end so that the hole is horizontally aligned.
 - ii) Position the steering cable rod end into the clevis bracket (Fig B43).
 - iii) Insert the quick release locking pin and lock in place using the hitch pin.

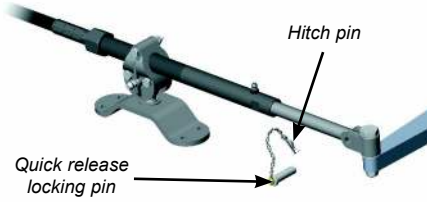

Fig B43 - Attaching the steering cable to the tiller

- Refer to section B9 on connecting the secondary steering cable to the drive unit.

B7d Quick Release

In an emergency situation the steering cable can be quickly disconnected from the tiller by pulling out the hitch pin and then removing the locking pin.

B7e Specification

Maximum stroke	8.5in (216mm)
Peak Thrust	330lbs / 136kg
Max Rudder Torque.....	185ft-lb (250Nm)
Hard Over Time	12-15 seconds
Peak Power	60 watts 5 amps
Average Power	1.25 amps
Tiller arm radius.....	7.5in /190mm
Max displacement.....	13,200lbs / 6,000kg
Max boat length.....	32ft / 10m
Voltage.....	12V DC
Clutch circuit power	850mA

B8 Routing Steering Cable

When deciding on the routing path for the Type R drive steering cable, consideration must be given to the following points:

- i) There must be sufficient slack in the cable to allow for any movements of the steering mechanism when steering from lock to lock - ensure that no part of the cable is under stress at any point of steering, otherwise damage to the cable may result over long term usage.
- ii) The chosen route should use the minimum possible number of bends.
- iii) If any bends are necessary, maximise the bend radius as much as possible. It is recommended that bends have a radius of no less than 6in (150mm) and that the combined total angle of all bends is no more than 270°.

B8a Cable Length Calculation

All Type R Drive System Packs are supplied as standard with a 6ft (1.8m) steering cable, which should be suitable for most installations. If a suitable location for mounting the drive unit is not available using this cable then other lengths are available as separate accessories.

Use a length of rope or electrical cable to plan out the steering cable route and then measure the total length required (Fig B44) :

$$\text{('A' Dimension + 'B' Dimension)} - 4\text{in for a } 90^\circ \text{ bend}$$

Round up the result to the nearest full foot size and then refer to section D1 for the appropriate custom cable order code.

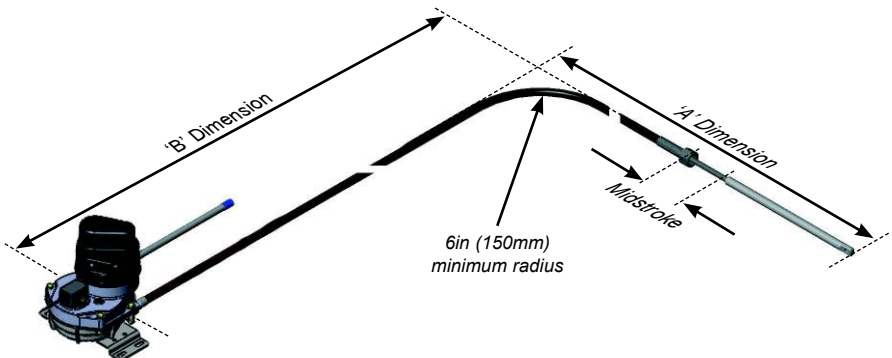

Fig B44 - Preferred cable routing

B9 Connecting Steering Cable To Drive

Either port can be used for the steering cable entry - select the most convenient for the installation.

- i) Remove the lock bolts, nuts and washers from both ports (Fig B45).
- ii) Insert the steering cable into the drive port. Using moderate force, guide the inner cable around the driving hub and out of the opposite port.
- iii) Push the steering cable jacket into the port until the retaining collar butts against the drive housing (Fig B46). If required, the cable can be "driven" into the drive by powering up the clutch and drive.

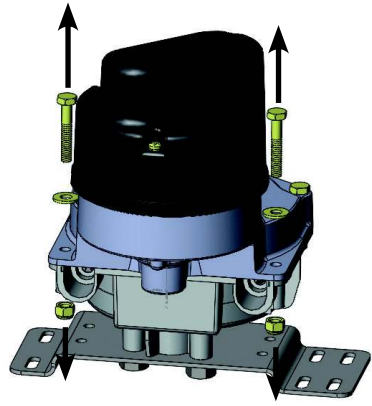

Fig B45 - Remove cable locking bolts

- iv) Insert the lock bolt to hold the cable in place.
- v) If undue force is required to insert the cable, this may be caused by the end of the inner cable fouling the outer face of the nylon guide. If this is the case, remove the cable and inspect for sharp edges. If possible, twist the cable so that the sharp edge is towards the inside of the radius, or use a file or burr type tool to remove the sharp edges.
- vi) Fit the spent cable tube to the opposite port and insert the lock bolt.
- vii) Fit washers & nuts to both lock bolts, tighten & torque to 40-45in-lbs (4Nm).

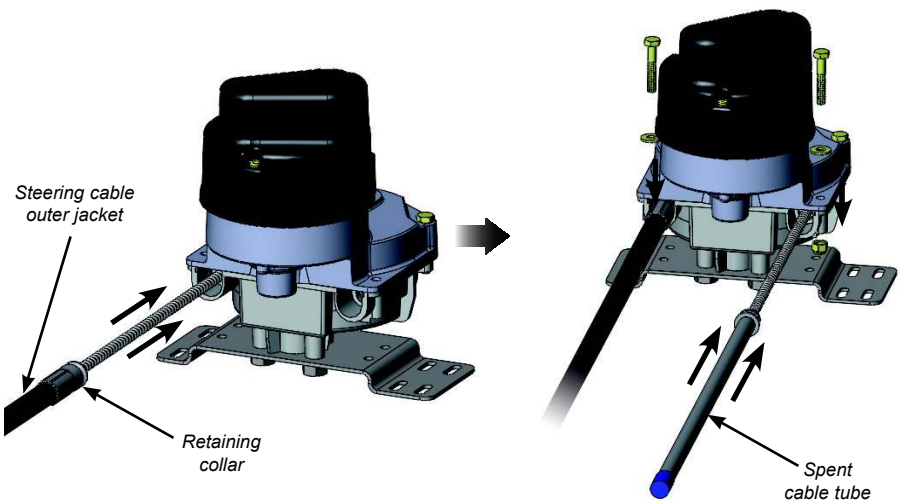

Fig B46 - Fitting steering cable and spent cable tube

B10 Rudder Feedback Unit (RFB) Installation & Calibration

Most autopilots require a rudder feedback device which is usually attached directly to the rudder - this complicates installation in certain applications, particularly with sterndrive and outboard engined boats. They are often exposed to the elements and prone to damage due to their location.

The optional Rudder Feedback Unit is a simple solution which attaches directly to the drive unit itself and is calibrated using a simple procedure.

A range of Rudder Feedback units are available which are compatible with most popular autopilot systems (Fig B47).

ORDER CODE	AUTOPILOT	RESISTOR
OC15SUK27A	COMNAV, SI-TEX	4k
OC15SUK27B	RAYMARINE	5k
OC15SUK27D	SIMRAD	3k
OC15SUK27E	FURUNO, TMQ, NAVMAN, GARMIN, COURSEMASTER, SI-TEX SP110	1k

Fig B47 - Rudder feedback compatibility

B10a Universal RFB Setup

If a dedicated RFB is not available for a brand of autopilot, the OC15SUK27 Universal RFB should be suitable. This module is configured to the particular autopilot using DIP switch settings:

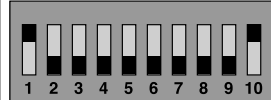
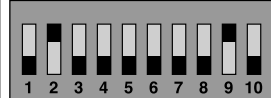
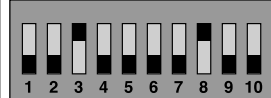
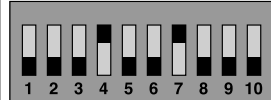
AUTOPILOT	DIPSWITCH	RESISTOR**
FURUNO, TMQ, NAVMAN, GARMIN, COURSEMASTER, SI-TEX SP110		1k
RAYMARINE		5k
SIMRAD*		3k
COMNAV, SI-TEX		4k

* Simrad autopilots also require Signal Conversion Module OC15SUK83

** Fixed resistance measured between black and white wire. Resistance between white and black wire is variable



DIP Switch

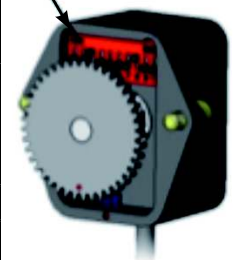

Fig B48 - Universal RFB DIP Switch Settings

B10b Calibration and Installation

The calibration routine should be performed after the drive unit has been fitted to the vessel and wired up to the autopilot. The RFB should also be electrically connected to the autopilot prior to calibration (refer to sections C1 and C2).

- i) Remove the RFB module from the drive housing (if already fitted) by removing the two fixing screws.
- ii) Center the rudder of the boat using the manual helm (you may need to run the engine to do this).
- iii) Calibrate the RFB by aligning the two red paint marks on the underside of the unit (Fig B49).
- iv) Remove the RFB blanking cap from the drive unit housing (Fig B50a).
- v) Fit the RFB to the drive housing and fix using the two screws provided (Fig B50b). Ensure that the RFB driven gear is correctly engaged with the drive gear before tightening the 2 screws.
- vi) Refer to the autopilot manufacturer's installation guide for instructions on any additional software controlled RFB fine calibration and hardover limitation.

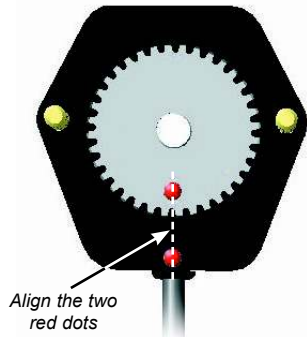

Fig B49 - Calibrating the rudder feedback unit

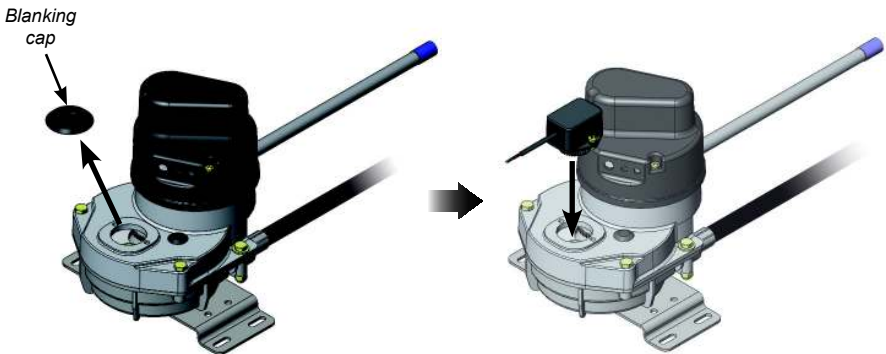

Fig B50 - Installing the rudder feedback unit

B11 Interference Evaluation (Outboard Engines Only)

It is vital that an operating clearance check is performed between the second steering cable, outboard fitting kit and the existing hardware including hoses, electrical cables and control cables before the system is connected to an autopilot system or the boat is taken to sea. Two people will be required to carry out this evaluation.

- i) While one person turns the steering wheel from full lock to full lock, the other person should observe the outboard engine movement and ensure that there is no physical interference between any parts across the full steering lock.
- ii) With the outboard set to full lock left, tilt the engine to the full up position and ensure that there is no physical interference between the parts at any stage. Repeat this procedure with the outboard set to full lock right.
- iii) It may be necessary to reroute hoses, electrical cables, control cables or other hardware to avoid interference during operation. All hardware must be well clear of the outboard fitting kit and second steering cable. Chafing may occur if parts are permitted to come into contact.

C ELECTRICAL INSTALLATION

C1 Connecting Drive to Autopilot

As the Type R Autopilot Drive is designed to work with most autopilot manufacturers' equipment, the wiring colors or connection references will differ slightly in each case. However, drive to autopilot connections are fundamentally the same for all makes of autopilot. The Type R drive has a simple four wire connection - two wires are for the drive motor power feed, the other two are for the clutch (Fig C1). Refer to the autopilot manufacturer's instructions for wiring information.

DRIVE CABLE	AUTOPILOT
RED	MOTOR +12V
BLACK	MOTOR -12V (0V)
GREEN	CLUTCH +12V
WHITE	CLUTCH -12V (0V)

Fig C1 - Motor and clutch cable connections

Note that the Type R drive requires a 12V input for both the motor drive and the clutch. Do not use with a 24V system.

C2 Rudder Feedback Unit

C2a Connection - non-Simrad Autopilots

- i) Connect the RFB Module wires to autopilot junction box - refer to Figs C2 and C3 for the correct wiring color connections for common autopilot brands.
- ii) Setup and calibrate the RFB as described in section B10.

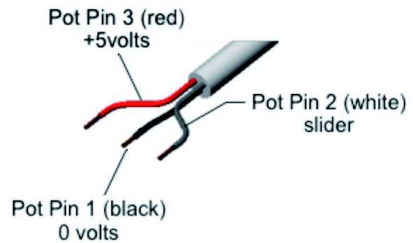

Fig C2 - RFB cable connections

RFB	RAYMARINE	NAVMAN	TMQ	COURSE-MASTER	COMNAV	GARMIN	SI-TEX	
							SP110	SP70/80
RED	RED	ORANGE	RED	ORANGE	POWER	RED	+VE	PIN 3
BLACK	GREEN	BLACK	BLUE	BLUE	COMMON	BLACK	-VE	PIN 1
WHITE	BLUE	BLUE	GREEN	BROWN	POSITION	YELLOW	WIP	PIN 2
SHIELD	SILVER	BLACK	BLACK	N/A	N/A	N/A	N/A	N/A

Fig C3 - Rudder Feedback connections by manufacturer

C2b Connection - Simrad Autopilots

The RFB Module OC15SUK27D **MUST** be used in conjunction with the Signal Conversion Module OC15SUK83 when integrating with Simrad Autopilots.

- i) **IMPORTANT** - all wiring connections must be made between the RFB Module, the Signal Conversion Module and the Autopilot Course Computer **BEFORE** powering up the Course Computer. Failing to follow this will result in the RFB signal not being recognized by the Course Computer. If this occurs perform the “Autopilot Reset” procedure (refer to Simrad autopilot manual).
- ii) Determine suitable site to mount the Signal Conversion Module. Shorten or insert suitable extension cable as required to suit the installation.
- iii) Connect the RFB Module, Signal Conversion Module and Autopilot Course Computer together as shown in Fig C4. Use a marine grade electrical connection strip and ensure the wires are properly insulated and protected.
- iv) Connect Octopus Signal Conversion Module output wires to Auto Pilot Junction Box following Auto Pilot installation and wiring diagram.
- v) Setup and calibrate the RFB as described in section B10.

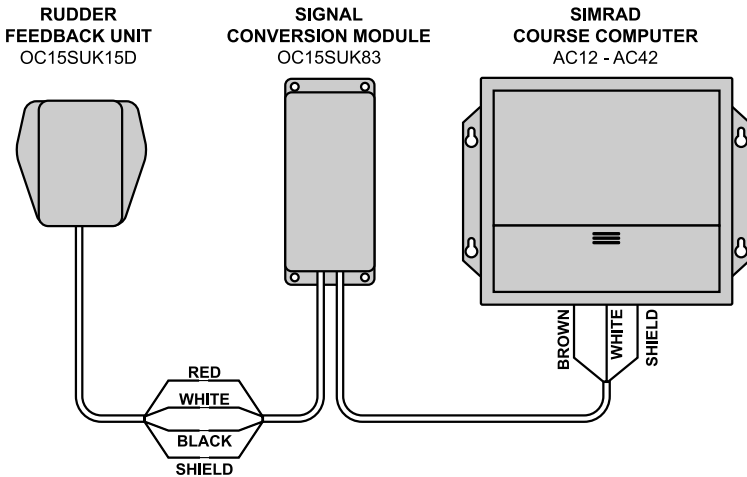

Fig C4 - RFB connections - Simrad Autopilots

D APPENDIX

D1 Accessories



OC15SUK12B Type B - Multi I/O Connection Kit – To Fit to Sterndrive Power Assist Steering Cylinders for Mercruiser engines (from 1994) and Volvo Gas engines & Volvo Diesel engines USA (from 1997)



OC15SUK12C Type C - Multi I/O Connection Kit – To fit to Sterndrive Power Assist Steering Cylinders for Mercruiser Saginaw (up to 1993) and Volvo Diesel drives Europe (from 1994)



OC15SUK15A Yamaha 115-220 O/B Installation Kit – for Second Steering Cable Connection to Outboard



OC15SUK15B Mercury-Mariner-Suzuki O/B Installation Kit – for Second Steering Cable Connection to Outboard



OC15109-6 Standard Steering Cable x 6 foot long
OC15109-9 Standard Steering Cable x 9 foot long
OC15109-12 Standard Steering Cable x 12 foot long



OC15SUK27 Rudder Feed Back Module – Universal Kit for all versions of Autopilots



OC15SUK27A Rudder Feed Back Module – For Comnav & Sitex
OC15SUK27B Rudder Feed Back Module – For Raymarine
OC15SUK27D Rudder Feed Back Module – For Simrad
OC15SUK27E Rudder Feed Back Module – For Coursemaster, Furuno, Garmin & TMQ



OC15SUK83 Simrad Signal Conversion Module – Required for Simrad Autopilots

D2 General Maintenance Guide

- Grease the installation kit by applying a grease gun to the grease nipple on the guide tube after installation and at regular intervals thereafter.
- Check the complete steering system and all fixings for security and integrity after a few hours of operation and at frequent intervals.
- Keep all moving parts free from build-up of salt and other foreign material - this will adversely affect their operation and create steering problems. Pay particular attention to the installation kit hardware.
- Inspect all parts periodically for corrosion. Any parts affected by corrosion must be replaced.
- Periodically remove the cable, clean the connector tube and thoroughly lubricate with a waterproof grease. Inspect the cable for cracks, splits or other damage. **DO NOT** cover cracks in the cable outer sheath with tape or other sealant; this will only delay a failure of the cable. Always replace the cable.
- When replacing fixings, self-locking nuts must always be used.
- The cable is a consumable item which should be replaced at regular intervals. It is recommended that the cable is replaced after 150 -200 hours of use or every two seasons. Note that incorrect installation, high torques or lack of maintenance will reduce the life of the cable. For extensive cruising and long passage making; it is recommended that a spare cable is kept onboard.



Octopus Products Inc.
Vancouver, Canada
Tel 604 940 2010
Fax 604 952 2650
www.octopusdrives.com
www.octopuseurope.com