

**GARMIN®**

# **FORCE® CURRENT TROLLING MOTOR**

---

**Owner's Manual**

© 2025 Garmin Ltd. or its subsidiaries

All rights reserved. Under the copyright laws, this manual may not be copied, in whole or in part, without the written consent of Garmin. Garmin reserves the right to change or improve its products and to make changes in the content of this manual without obligation to notify any person or organization of such changes or improvements. Go to [www.garmin.com](http://www.garmin.com) for current updates and supplemental information concerning the use of this product.

Garmin®, the Garmin logo, ActiveCaptain®, and Force® are trademarks of Garmin Ltd. or its subsidiaries, registered in the USA and other countries. These trademarks may not be used without the express permission of Garmin.

Wi-Fi® is a registered mark of Wi-Fi Alliance Corporation.

# Table of Contents

## Important Information..... 1

## Getting Started..... 2

Installing the Motor on the Mount.....	3
Adjusting the Depth of the Trolling Motor.....	4
Checking the Propeller Clearance.....	4
Connecting to Power.....	5
Stowing the Motor.....	6
Deploying the Motor.....	6
Removing the Motor from the Mount....	7
Status Indicator.....	8
Changing the Propeller.....	10

## Remote Control..... 11

Remote Control Screen.....	13
Navigating the Menu.....	14
Gesture Controls.....	14
Using Gesture Controls to Steer.....	14
Using Gesture Controls to Adjust the Heading Hold.....	14
Using Gesture Controls to Adjust Your Held Position.....	14
Installing Batteries in the Remote Control.....	14
Attaching a Lanyard.....	15
Calibrating the Remote Control.....	15
Pairing the Remote Control.....	15
Pairing an Additional Remote Control.....	16

## Operation..... 16

Turning the Propeller On and Off.....	16
Adjusting the Speed of the Motor....	16
Operating the Propeller When Partially Deployed.....	17
Steering the Trolling Motor Manually..	17
Reverse Thrust.....	17
Shifting Between Forward and Reverse Mode.....	18
Waypoints.....	18
Creating a Waypoint.....	18
Navigating to a Waypoint.....	18
Viewing Waypoint Details.....	18
Editing a Waypoint Name.....	18

Deleting a Waypoint.....	18
Routes.....	19
Navigating a Route.....	19
Viewing Route Details.....	19
Editing a Route Name.....	19
Deleting a Route.....	19
Tracks.....	19
Saving the Active Track.....	20
Clearing the Active Track.....	20
Navigating to the Start of the Active Track.....	20
Navigating a Saved Track.....	20
Viewing Saved Track Details.....	20
Editing a Saved Track Name.....	20
Deleting a Saved Track.....	20

## Autopilot..... 21

Calibrating the Trolling Motor	
Compass.....	21
Acquiring a GPS Signal.....	22
Adjusting the Autopilot Response.....	22
Maintaining Your Speed.....	22
Holding Your Position.....	22
Maintaining Your Heading.....	23
Changing the Heading Hold Behavior.....	23
Navigating.....	23
Pausing and Resuming Navigation..	23
Stopping Navigation.....	24

## Settings..... 24

Trolling Motor Settings.....	24
Wireless Network Settings.....	24
Battery Management Settings.....	25
Remote Control Settings.....	25
Backlight Settings.....	25

## MOB Tag..... 26

Attaching the Band or Carabiner Loop.....	27
Overriding the MOB Tag.....	27
Pairing an MOB Tag with the Force Current Trolling Motor.....	28
Replacing the MOB Tag Battery.....	29

## Power Steer Foot Pedals..... 29

Attaching the Pedals to the Rails.....	30
--	----

Steering with the Foot Pedals.....	31
Inverting the Steering Response.....	32
Using the Foot Pedal Levers.....	32
Changing the Function of the Foot Pedal Levers.....	32
Pairing the Foot Pedals.....	32
Installing Batteries in the Foot Pedals.....	33
Status LED.....	33

**Connecting to a Mobile Device with  
the ActiveCaptain App..... 33**

**Connecting to a Chartplotter..... 34**

**Connecting to a Garmin Watch..... 34**

**Software Updates..... 34**

**Maintenance Needs and Schedule.. 35**

Replacing the Pull Rope.....	36
Installing the Rope Handle.....	36
Checking the Sacrificial Anodes.....	37

**Specifications..... 38**

Trolling Motor.....	38
Dimensions.....	39
Power Steer Foot Pedals.....	40
Dimensions.....	41
Remote Control.....	42
MOB Tag.....	42

# Important Information

## WARNING

See the *Important Safety and Product Information* guide in the product box for product warnings and other important information.

You must remove the trolling motor from the kayak before transporting the kayak. Transporting the kayak with the trolling motor on the mount may lead to an accident causing serious personal injury and property damage.

Do not run the motor when the propeller is out of the water. Contact with the rotating propeller may result in severe injury.

Do not use the motor in areas where you or other people in the water may come into contact with the rotating propeller, which could result in severe injury.

Use caution when operating the trolling motor near hazards in the water, such as trees, shallow rocks, docks, pilings, and other boats.

Always disconnect the motor from the battery before handling or working with the propeller, propeller drive motor, electrical connections, or electronics enclosures to avoid serious injury or death.

Always carry a paddle on your kayak, to avoid the possibility of becoming stranded on the water in the event of an unexpected power failure or other issue preventing the use of the trolling motor.

When using the trolling motor to drive your kayak backward, the kayak may steer unexpectedly, due to the hull interfering with the motor thrust. You must stay alert and aware of your surroundings when using the motor to move your kayak backward, to avoid possible personal injury or product damage caused by an accidental collision.

## CAUTION

When transporting the trolling motor, always use the handle on the back of the steering system housing and be mindful of the propeller drive motor and the propeller, to prevent the possibility of personal injury or property damage.

You should make sure the motor is in the stowed position before entering or exiting the kayak. Accidentally driving the kayak while entering or exiting it may lead to personal injury or property damage.

## NOTICE

You should use the Force Current trolling motor with the high-efficiency propeller only in open-water conditions. When using the high-efficiency propeller in shallow water conditions, there is an increased risk of damaging the propeller if the motor collides with an underwater obstacle.

# Getting Started

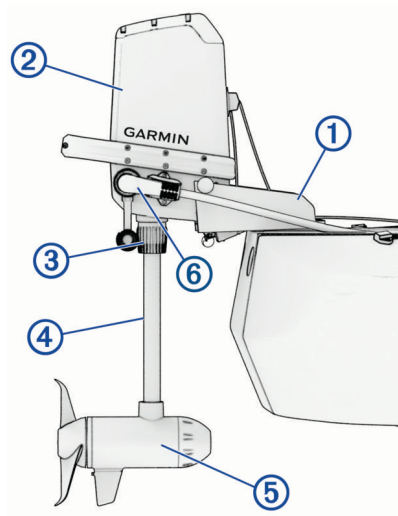

①	Mount
②	Steering system
③	Depth adjustment collar
④	Shaft
⑤	Propeller drive motor
⑥	Power cable connector

## Installing the Motor on the Mount

### ⚠ CAUTION

When transporting the trolling motor, always use the handle on the back of the steering system housing and be mindful of the propeller drive motor and the propeller, to prevent the possibility of personal injury or property damage.

- 1 If necessary, loosen the pivot knobs on both sides of the trolling motor.
- 2 Lower the motor onto the mount at an approximately 45-degree angle, matching the pivot knobs on the motor with the pivot brackets on the mount.

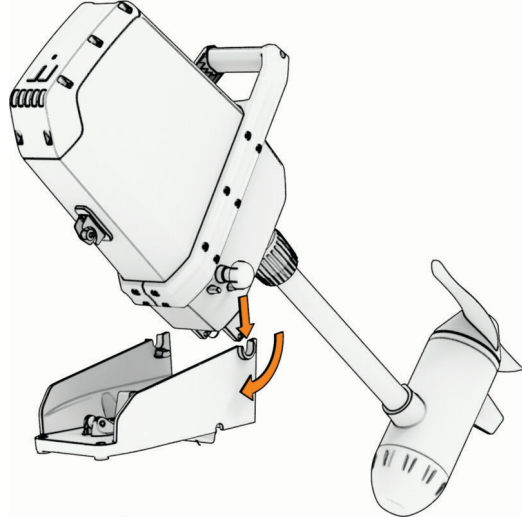

- 3 Allow the motor to pivot down to a vertical position.
- 4 Tighten the knobs on either side of the motor until they stop.
- 5 Start the pull rope partly into the eyelet on the front of the motor steering system, and pull the upper part of the rope up until it slips into the eyelet.

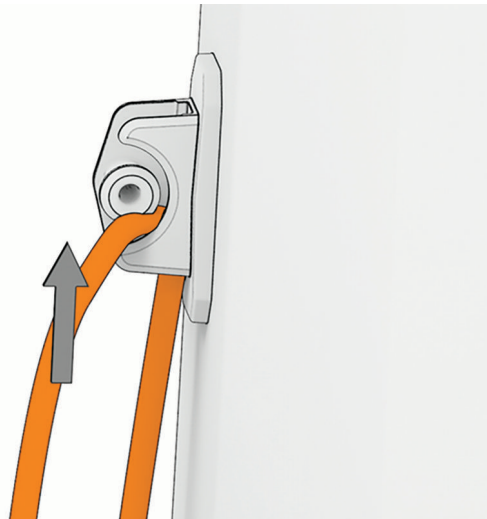

## Adjusting the Depth of the Trolling Motor

### ⚠ WARNING

Before you set the motor depth, you must make sure there is enough clearance for the propeller throughout the rotation of the motor shaft ([Checking the Propeller Clearance, page 4](#)).

- 1 Loosen the collar at the base of the steering system housing.



- 2 Raise or lower the depth of the trolling motor.
- 3 After you have set the motor to the desired depth, tighten the collar at the base of the steering system housing.

## Checking the Propeller Clearance

### ⚠ WARNING

Before turning on the trolling motor, you must make sure there is enough clearance between the propeller and the hull through the entire rotation of the motor shaft. Installing the motor with insufficient space between the propeller and the hull may result in personal injury and property damage if the propeller contacts the hull during use.

- 1 Rotate the propeller drive motor manually to check the clearance through a complete 360-degree rotation of the shaft.

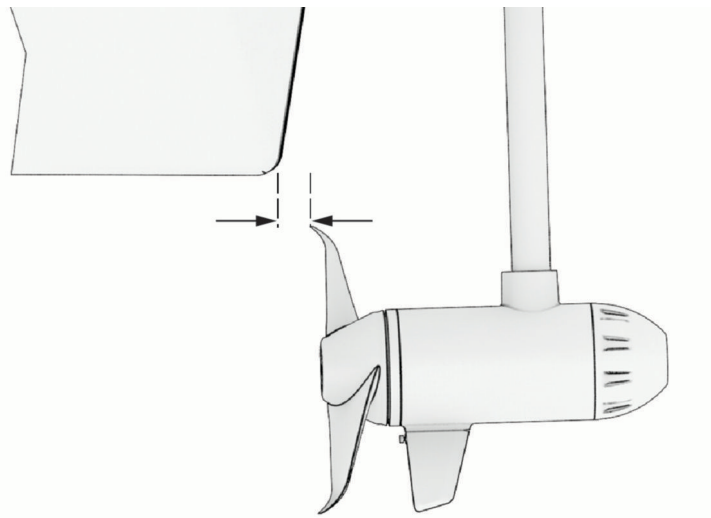

- 2 If necessary, adjust the motor depth to ensure sufficient space between the propeller and the hull ([Adjusting the Depth of the Trolling Motor, page 4](#)).

## Connecting to Power

### WARNING

To avoid possible serious personal injury or property damage, the circuit breaker must be in the off position before you connect the trolling motor power cable to it.

You must connect the positive (+) wire on the power cable through a circuit breaker or a fuse rated for 40 A (continuous). Connecting this wire to power without a circuit breaker or fuse could result in a short on the wire, which may lead to overheating and a possible fire.

### NOTICE

You must connect the Force Current trolling motor to a 12 or 24 Vdc battery. Connecting the motor to other voltages may cause poor performance or product damage.

- 1 Connect the trolling motor power cable to the battery, routing the red (+) wire through a circuit breaker rated for 40 A (continuous).
- 2 Turn the weather cap on the trolling motor power connector a quarter-turn counterclockwise to expose the power connector.
- 3 Insert the power cable connector, with the cable approximately parallel to the kayak, and push until it is fully inserted.

**NOTE:** Make sure the locking collar on the power cable connector is in the unlock position, before connecting it to the motor.

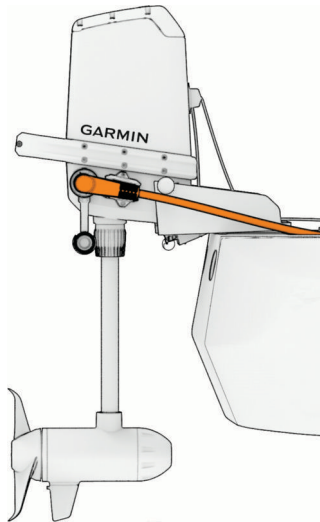

The power cable strain relief rests against the cradle on the motor housing.

- 4 Turn the locking ring on the power cable connector a quarter-turn clockwise to lock it in place.

## Stowing the Motor

- 1 Pull the rope handle toward the motor, lifting the propeller drive motor out of the water.
- 2 Lower the rope so that it catches in the cleat, and gently release the tension.

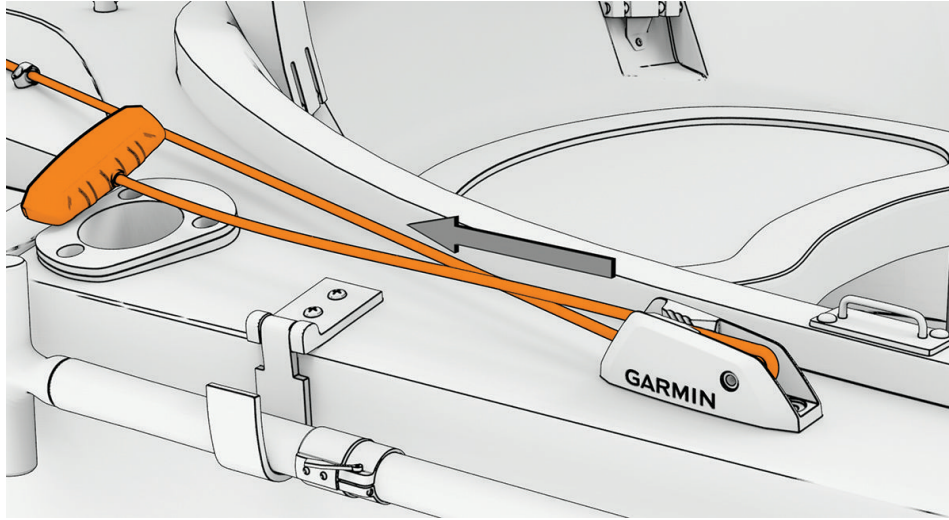

The rope is secure under tension in the cleat, holding the motor in the stowed position.

## Deploying the Motor

- 1 Pull the handle up and back to release the rope from the cleat.

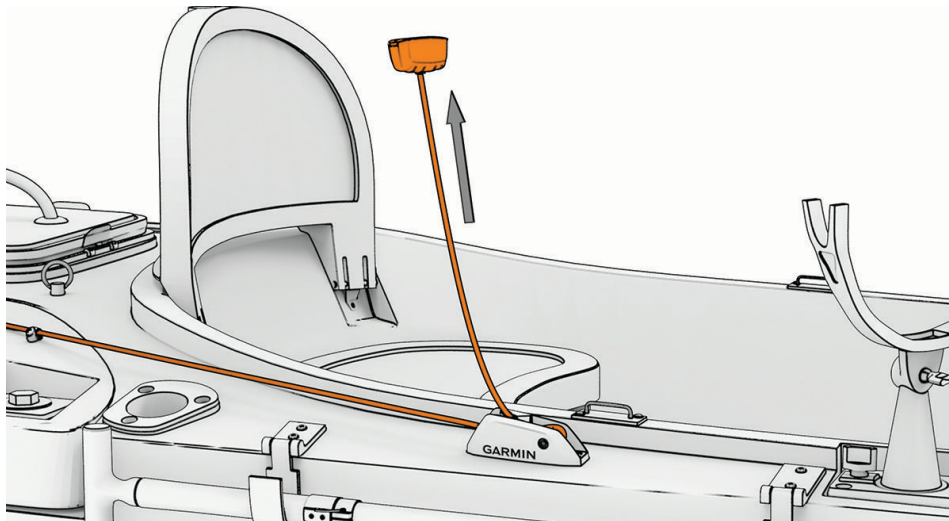

- 2 Gently release the tension on the rope to lower the propeller drive motor into the water until it stops. The mount latch engages the locking pin, holding the motor in the deployed position.

## Removing the Motor from the Mount

You must switch off the circuit breaker and disconnect the power cable from the motor before removing the motor from the mount.

You must transition the motor to the deployed position (*Deploying the Motor, page 6*), or release the rope from the cleat and support the motor using the handle on the back of the steering system housing, before removing the motor from the mount.

### **⚠ WARNING**

You must remove the trolling motor from the kayak before transporting the kayak. Transporting the kayak with the trolling motor on the mount may lead to an accident causing serious personal injury and property damage.

### **⚠ CAUTION**

When transporting the trolling motor, always use the handle on the back of the steering system housing and be mindful of the propeller drive motor and the propeller, to prevent the possibility of personal injury or property damage.

- 1 Pull the top of the rope partly out of the open side of the eyelet on the front of the motor steering system, and pull the lower part of the rope down until it slips out of the eyelet.

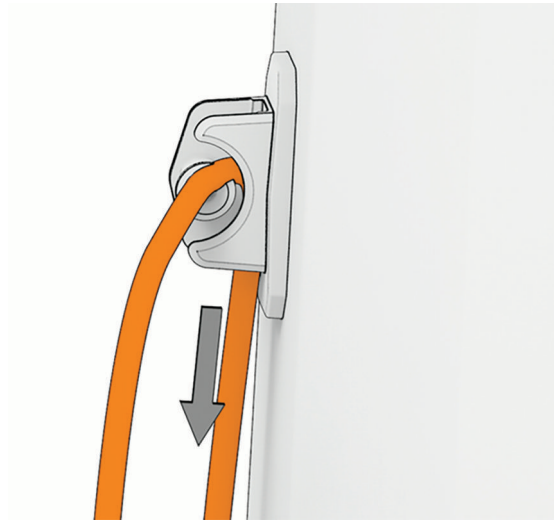

- 2 Unscrew the knobs on both sides of the motor until they stop.

- 3 Tilt the motor up to an approximately 45-degree angle using the handle on the back of the motor.  
If the motor is in the deployed position, you must pull the rope up to release the mount latch before you can tilt the motor.

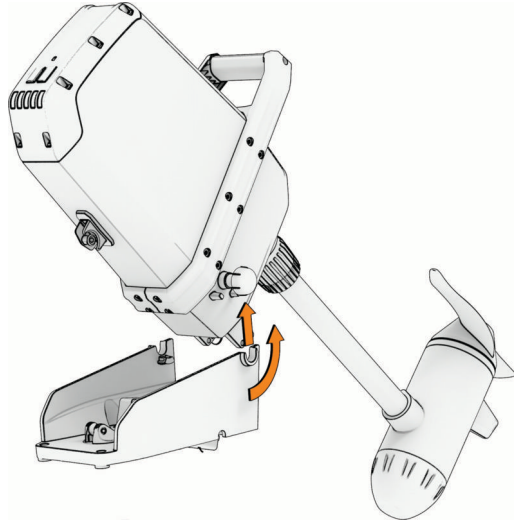





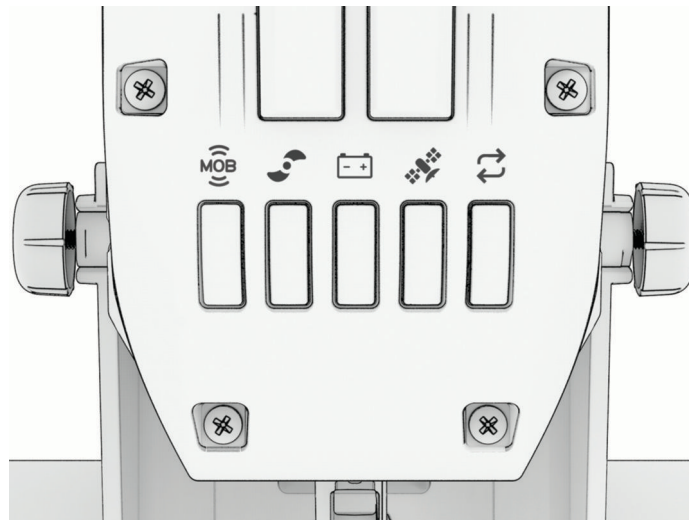

- 4 Lift the motor off of the mount using both hands.

## Status Indicator

The status LEDs on the top panel of the trolling motor indicate the status of the motor.



	<p>Man Overboard (MOB) tag (<a href="#">MOB Tag, page 26</a>):</p> <ul style="list-style-type: none"> <li>• Solid green: MOB tag is connected.</li> <li>• Flashing red: MOB tag connection has been lost. The propeller is disabled.</li> </ul> <p><b>NOTE:</b> After the MOB tag connection is restored, you must press the  button on the MOB tag, or dismiss the notification on the remote control or on a connected chartplotter, before you can turn on the propeller.</p> <ul style="list-style-type: none"> <li>• Solid red: MOB tag is not connected. The propeller is disabled.</li> <li>• Flashing yellow: MOB tag is not connected, and MOB Tag Override Mode is on. The propeller is not disabled (<a href="#">Overriding the MOB Tag, page 27</a>).</li> </ul>
	<p>Propeller and autopilot status:</p> <ul style="list-style-type: none"> <li>• Solid green: The propeller is on.</li> <li>• Flashing green: Autopilot mode is enabled.</li> <li>• Off: The propeller is off.</li> </ul>
	<p>Battery status:</p> <ul style="list-style-type: none"> <li>• Solid green: The battery level is good.</li> <li>• Solid yellow: The battery level is medium.</li> <li>• Solid red: The battery level is low.</li> <li>• Flashing red: The battery level is critically low.</li> </ul> <p><b>NOTE:</b> By default, the battery level indicator is optimized for lithium iron phosphate batteries (<a href="#">Battery Management Settings, page 25</a>).</p>
	<p>GPS status:</p> <ul style="list-style-type: none"> <li>• Solid green: The motor has a good GPS signal.</li> <li>• Solid yellow: The motor has a poor GPS signal.</li> <li>• Solid red: The motor does not have GPS signal.</li> </ul>
	<p>Status:</p> <ul style="list-style-type: none"> <li>• Solid green: There are no errors.</li> <li>• Solid blue: The motor is in pairing mode.</li> <li>• Solid red: An error has occurred<sup>1</sup>.</li> <li>• Flashing red: A critical error has occurred.</li> </ul>
<p>All</p>	<p>Alternating flashing green: The motor, remote control, or foot pedals are installing a software update.</p>

<sup>1</sup> After resolving the error, you may need to turn the motor off and back on again to clear the red error LED.

## Changing the Propeller

### WARNING

Always disconnect the motor from the battery before handling or working with the propeller to avoid serious injury or death.

### NOTICE

You should use the Force Current trolling motor with the high-efficiency propeller only in open-water conditions. When using the high-efficiency propeller in shallow water conditions, there is an increased risk of damaging the propeller if the motor collides with an underwater obstacle.

The Force Current trolling motor includes a high efficiency propeller and a weedless propeller. Follow these steps when changing propellers.



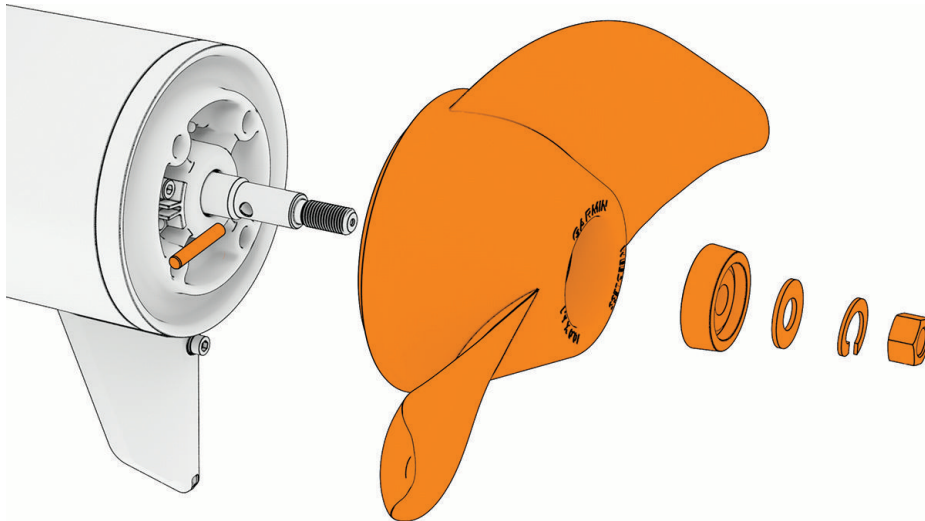



- 1 Using a  $\frac{9}{16}$  in (15 mm) socket, remove the nut that secures the propeller.



- 2 Remove the propeller and set aside the lock washer, flat washer and sacrificial anode.
- 3 Make sure the pin in the propeller motor shaft is in place, and replace it if necessary.
- 4 Install the new propeller.
- 5 Place the anode, flat washer, lock washer, and nut back on the propeller drive shaft.
- 6 Using a  $\frac{9}{16}$  in (15 mm) socket, tighten the nut to 16.27 N-m (12 lbf-ft) to secure the propeller.

# Remote Control





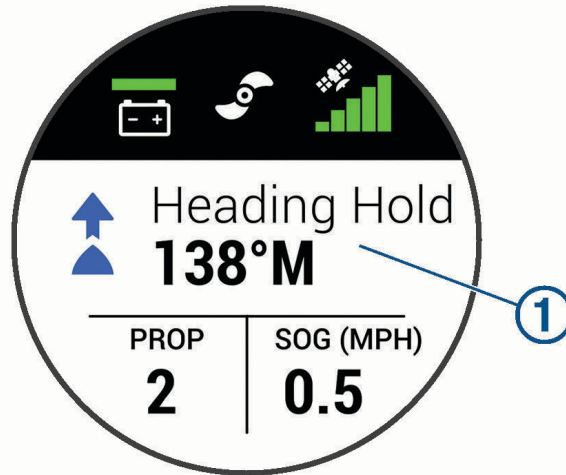

Button	Description
	Hold to turn the remote control on and off.
	Press to turn on and set cruise control at the current speed over ground (SOG) ( <a href="#">Maintaining Your Speed, page 22</a> ). Press again to disable cruise control and return to manual speed control.
	Press twice to turn on the propeller and set it to full speed. Press again to return to the previous speed and propeller state.
	Press for manual control ( <a href="#">Steering the Trolling Motor Manually, page 17</a> ). Hold to steer using gestures ( <a href="#">Using Gesture Controls to Steer, page 14</a> ).
	Press once to turn the propeller on or off ( <a href="#">Turning the Propeller On and Off, page 16</a> ). Press twice to turn off any autopilot function (if enabled), stop the propeller, and shift between forward and reverse thrust ( <a href="#">Reverse Thrust, page 17</a> ).
	Press to navigate the menu ( <a href="#">Navigating the Menu, page 14</a> ).  When in the menu, press  to select a menu item, and press  to go back without saving. When in anchor lock, press to jog the anchor lock position forward, backward, left, or right in 1.5 m (5 ft.) increments.  When in heading hold or manual control, press  and  for single-degree step turns, or hold for steering in five-degree increments.  Press  and  for incremental speed changes, or hold for continuous speed changes.  When your speed is set to zero, press  to shift into reverse ( <a href="#">Reverse Thrust, page 17</a> ).
	Press to turn on heading hold. Heading hold uses the trolling motor to maintain your current heading ( <a href="#">Maintaining Your Heading, page 23</a> ). Press again to turn off heading hold, stop the propeller, and resume manual control. Hold to set the heading hold by pointing the remote ( <a href="#">Gesture Controls, page 14</a> ).
	Press to turn on anchor lock. Anchor lock uses the trolling motor to hold your position ( <a href="#">Holding Your Position, page 22</a> ). Press again to turn off anchor lock and return to the previous steering mode. Hold to jog the anchor lock position by pointing the remote ( <a href="#">Using Gesture Controls to Adjust Your Held Position, page 14</a> ).
	Press to open the menu. Press to exit the menu.
	Press to mark a waypoint.
1 through 4	Press to open the shortcut for the Garmin® chartplotter assigned to the button. <sup>2</sup>

<sup>2</sup> Requires a connection to a compatible Garmin chartplotter. See your chartplotter owner's manual for instructions.

## Remote Control Screen









	<p>Shows the operational status of the trolling motor. For example, when in manual control, Manual is shown, and when the heading hold is on, Heading Hold is shown, along with the heading-hold set point in degrees.</p>
	<p>Shows the trolling motor battery status. Green: the motor battery voltage level is good. Yellow: the motor battery voltage level is medium. Red: the motor battery voltage level is low. Flashing red: the motor battery voltage level is critically low.</p> <p><b>NOTE:</b> By default, the battery level indicator is optimized for lithium iron phosphate batteries (<a href="#">Battery Management Settings, page 25</a>).</p> <p><b>TIP:</b> You can change the appearance of the trolling motor battery status so that it shows a numeric voltage instead of an icon (<a href="#">Trolling Motor Settings, page 24</a>).</p> <p>You can view the remote control battery level by pressing .</p>
	<p>Shows the status of the propeller. White and rotating: the propeller is providing a forward thrust. Red and rotating: the propeller is providing a reverse thrust.<sup>3</sup> Not rotating: the propeller is on with the speed set to zero. Not shown: the propeller is off.</p>
	<p>Shows the GPS signal strength of the trolling motor.</p>
<p>PROP</p>	<p>Shows the speed level of the propeller (<a href="#">Adjusting the Speed of the Motor, page 16</a>). When the propeller is actively providing a reverse thrust, the speed level is shown in red.<sup>4</sup> <b>NOTE:</b> The propeller speed is not shown when the motor is using cruise control.</p>
<p>SOG</p>	<p>Shows the measured speed over ground (SOG).</p>

<sup>3</sup> The motor may run louder in reverse thrust than in forward thrust.

<sup>4</sup> In reverse thrust, the motor runs louder, produces less thrust, and is less efficient than in forward thrust.

## Navigating the Menu

You can use the menu and arrow keys to navigate the menu on the remote control.



- To open the menu, press .
- To move between different menu items, press  and .
- To select a menu item, press .
- To move back to a previous menu item, press .
- To exit the menu, press  or press  repeatedly until you reach the main screen.

## Gesture Controls

You can point or move the remote control to interact with the trolling motor. You must calibrate the compass in the trolling motor ([Calibrating the Trolling Motor Compass, page 21](#)), and the compass in the remote control ([Calibrating the Remote Control, page 15](#)) before you can use gesture controls.



### Using Gesture Controls to Steer

You can steer the motor by pointing the remote control.

- 1 If necessary, turn on the propeller ([Turning the Propeller On and Off, page 16](#)).
- 2 Hold .
- 3 While holding , point the remote control to the left or right to steer port or starboard.
- 4 Release  to stop steering.



### Using Gesture Controls to Adjust the Heading Hold

You can move the remote control to adjust your heading hold ([Maintaining Your Heading, page 23](#)).

- 1 If necessary, turn on the propeller ([Turning the Propeller On and Off, page 16](#)).
- 2 Hold .
- 3 Point the remote control toward where you want to adjust the heading.
- 4 Release  to set the heading direction.

### Using Gesture Controls to Adjust Your Held Position

You can move the remote control to adjust your position when using the anchor lock feature ([Holding Your Position, page 22](#)).

- 1 Hold .
- 2 Point the remote control in the direction you want to move your position.  
Your position jogs 1.5 m (5 ft.) in the direction you point.
- 3 Release .
- 4 Repeat this procedure until the you are in the position you want.

## Installing Batteries in the Remote Control

The remote control operates using two AA batteries (not included). Use lithium batteries for best results.

- 1 Turn the D-ring counter-clockwise, and pull up to remove the cover.
- 2 Insert two AA batteries, observing polarity.
- 3 Replace the battery cover, and turn the D-ring clockwise.

## Attaching a Lanyard

- 1 Starting from the back of the remote control, insert the loop of the lanyard ① through the slot.

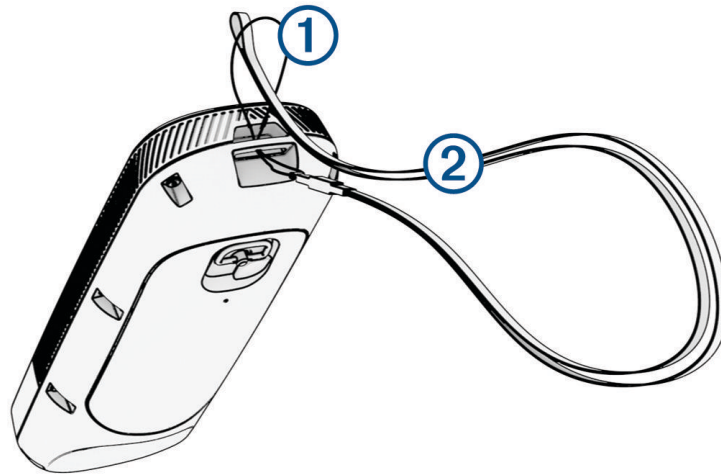

- 2 Thread the other end of the lanyard ② through the loop, and pull it tight.
- 3 If necessary, place the lanyard around your neck or wrist to tether it during use.

## Calibrating the Remote Control

### NOTICE



Calibrate the electronic compass outdoors. To improve heading accuracy, do not stand near objects that influence magnetic fields, such as vehicles, buildings, and overhead power lines.

You must calibrate the compass in the remote control before you can control the motor using gestures. If the gesture controls are not working properly after calibration, you can repeat this process as often as needed.

- 1 Select  > **Settings** > **Remote Control** > **Calibrate**.
- 2 Select **Start**, and follow the on-screen instructions.

## Pairing the Remote Control



The remote control is paired with the trolling motor at the factory. Follow these steps if you need to pair it again.

- 1 Turn on the trolling motor.
- 2 Press  on the trolling motor three times to enter pairing mode.  
The  status LED on the trolling motor illuminates blue as it searches for a connection.
- 3 Bring the remote control within 1 m (3 ft.) of the trolling motor.
- 4 Turn on the remote control.
- 5 On the remote control, select  > **Settings** > **Remote Control** > **Pairing** > **Pair** > **Start**.  
After a few seconds, Pairing Complete is shown on the remote control.

## Pairing an Additional Remote Control

You can have up to two remote controls connected to your trolling motor at the same time.

To pair a second remote control, you must follow these steps using the first connected remote control.

- 1 Turn on the trolling motor.
- 2 On a remote control already paired to the motor, select  > **Settings** > **Remote Control** > **Pairing** > **Add Additional Remote**.
- 3 Bring the additional remote control within 1 m (3 ft.) of the display panel on the trolling motor.
- 4 Turn on the additional remote control.
- 5 On the additional remote control, select  > **Settings** > **Remote Control** > **Pairing** > **Pair** > **Start**.  
Device Found appears on the first remote control. After a few seconds, Pairing Complete appears on the second remote control.

## Operation

You can operate every feature of the trolling motor using the included remote control (*Remote Control*, page 11).

In addition to the remote control, you can control certain features of the Force Current trolling motor using any of the following devices:

- the Power Steer foot pedals, included with some models (*Power Steer Foot Pedals*, page 29).
- a mobile device with the ActiveCaptain® app (*Connecting to a Mobile Device with the ActiveCaptain App*, page 33).
- a compatible Garmin chartplotter (*Connecting to a Chartplotter*, page 34).<sup>5</sup>
- a compatible Garmin watch (*Connecting to a Garmin Watch*, page 34).



For details on controlling the trolling motor using a watch or a chartplotter, see the *Owner's Manual* for the specific device.

## Turning the Propeller On and Off

### **WARNING**

Do not use the motor in areas where you or other people in the water may come into contact with the rotating propeller, which could result in severe injury.

Do not run the motor when the propeller is out of the water. Contact with the rotating propeller may result in severe injury.

- 1 If necessary, deploy the trolling motor (*Deploying the Motor*, page 6).  
**NOTE:** The propeller cannot turn on when the trolling motor is in the stowed position.
- 2 On the remote control, press  to turn on the propeller.
- 3 Press  again to turn off the propeller.

## Adjusting the Speed of the Motor

On the remote control, press  or  to increase or decrease your speed.

In manual mode, the propeller speed, shown in the PROP field on the remote control screen, increases or decreases accordingly.

In cruise control mode, the current target speed is displayed on the trolling motor remote screen, and it increases or decreases accordingly.

**NOTE:** In manual mode, increasing or decreasing the speed using the remote control does not automatically turn the propeller on. You must press the  button on the remote control to turn on the propeller.

<sup>5</sup> Some ECHOMAP™ Ultra and ECHOMAP UHD chartplotters that no longer receive software updates do not support some features of the Force Current trolling motor. You must use the trolling motor remote for initial set-up.

## Toggling Full Speed

1 On the remote control, press  twice.

The trolling motor propeller speed quickly increases to full speed.

2 Press  to return to the previous propeller speed.

**TIP:** When at full speed, you can press  on the remote control to slowly decrease the propeller speed.

## Operating the Propeller When Partially Deployed

### WARNING

Do not run the motor when the propeller is out of the water. Contact with the rotating propeller may result in severe injury.

You should only operate the trolling motor propeller with the motor partially deployed in limited circumstances, such as passing over weeds or submerged obstacles. Otherwise, you or someone else could come into contact with the rotating propeller, which could cause severe injury.

### CAUTION

Before lifting the motor partly out of the water, you must press  on the remote control to make sure the motor is in manual mode. Lifting the motor out of the water while it is running in an autopilot mode may cause unexpected movement of the motor or kayak, possibly causing personal injury or property damage.

### NOTICE

You should use the Force Current trolling motor with the high-efficiency propeller only in open-water conditions. When using the high-efficiency propeller in shallow water conditions, there is an increased risk of damaging the propeller if the motor collides with an underwater obstacle.

1 With the trolling motor in the deployed position, pull the rope handle slowly to lift the motor until it is in position to pass over the weeds or obstacle.

If you lift the motor too far out of the water, the propeller turns off automatically.

2 Turn the propeller on and set the propeller speed as needed to move the boat past the obstruction.

3 When you are past the obstacle, slowly lower the motor back to the deployed position.

## Steering the Trolling Motor Manually

Manual mode is the default operational mode of the trolling motor. In manual mode, you can adjust the direction and speed of the trolling motor as needed.

**NOTE:** The trolling motor is in manual mode by default when you turn it on.

1 If necessary, on the remote control, select .

2 Select an action:

- Using the remote control, press  and  to steer.

**NOTE:** You can also use gesture controls to steer the boat manually using the remote control ([Using Gesture Controls to Steer, page 14](#)).

- Using the foot pedal, push the pedal with your toes and heel to steer.

## Reverse Thrust

In manual mode, you can run the propeller in reverse. Running the propeller in reverse for short periods of time can be useful in some situations, such as backing out of a tight space with less steering of the motor.

Because the propeller on the trolling motor is designed primarily for forward thrust, it is less efficient at creating reverse thrust, resulting in more noise from the motor, especially at higher propeller speeds, and more turbulence underwater.

### NOTICE

You should use reverse thrust sparingly to minimize cavitation and excessive wear on the propeller and the propeller drive motor.

## Shifting Between Forward and Reverse Mode

- 1 Press  twice.

The  icon on the remote control screen turns red when the propeller is set to reverse. If the motor is running in an autopilot mode, it automatically switches to manual mode. If the propeller is running, it automatically stops.

- 2 Press  again to turn the propeller on.

**NOTE:** When shifting between forward and reverse mode, the propeller speed is automatically set to the last speed you used in the same thrust mode.

## Waypoints

Waypoints are used to mark locations so you can return to them later. The trolling motor can store up to 5000 waypoints.

When the trolling motor is connected to a chartplotter, the waypoints stored on the trolling motor and on the chartplotter are automatically synchronized.

**NOTE:** Because the systems are synchronized, when you delete waypoints, restore default settings, or clear user data using the trolling motor remote, the waypoints on the chartplotter are also deleted. Likewise, if you delete a waypoint from the chartplotter, it is automatically deleted from the trolling motor.

## Creating a Waypoint

You can save your current location as a waypoint.

- 1 If necessary, drive to a location you want to save as a waypoint.
- 2 On the remote control, press .

## Navigating to a Waypoint

- 1 On the remote control, select  > **Waypoints**.  
A list of the ten closest waypoints is shown.
- 2 Select a waypoint.
- 3 Select **Navigate To**.
- 4 Turn on the propeller (*Turning the Propeller On and Off*, page 16).  
The trolling motor drives to the waypoint location (*Navigating*, page 23).

## Viewing Waypoint Details

- 1 On the remote control, select  > **Waypoints**.  
A list of the ten closest waypoints is shown.
- 2 Select a waypoint.
- 3 Select **Review**.

## Editing a Waypoint Name

- 1 On the remote control, select  > **Waypoints**.  
A list of the ten closest waypoints is shown.
- 2 Select a waypoint.
- 3 Select **Edit**.
- 4 Enter a new name for the waypoint.

## Deleting a Waypoint

- 1 On the remote control, select  > **Waypoints**.  
A list of the ten closest waypoints is shown.
- 2 Select a waypoint.
- 3 Select **Delete**.

## Routes

A route is a sequence of locations that leads you to your final destination.

When you connect the trolling motor to a chartplotter, the routes stored on the chartplotter are synchronized with the routes stored on the trolling motor. Deleting or editing routes on one device automatically changes the routes stored on the other device. You can create routes on the chartplotter only.

You can save up to 100 routes.

### Navigating a Route

- 1 On the remote control, select  > **Routes**.

A list of the ten closest routes is shown.

- 2 Select a route.

- 3 Select **Navigate To**.

- 4 Select an option:

- To navigate the route from the starting point used when the route was created, select **Forward**.
- To navigate the route from the destination point used when the route was created, select **Backward**.
- To navigate from your current location to the beginning of the route, then navigate the route, select **From Start**.

- 5 Turn on the propeller (*Turning the Propeller On and Off*, page 16).

The trolling motor drives along the route in the chosen direction (*Navigating*, page 23).

As you approach the end of the route, by default, the trolling motor switches to the anchor lock feature and holds position at the end of the route. You can change this behavior in the settings (*Trolling Motor Settings*, page 24).

### Viewing Route Details

- 1 On the remote control, select  > **Routes**.

A list of the ten closest routes is shown.

- 2 Select a route.

- 3 Select **Review**.

### Editing a Route Name

- 1 On the remote control, select  > **Routes**.

A list of the ten closest routes is shown.

- 2 Select a route.

- 3 Select **Edit**.

- 4 Enter a new name for the route.

### Deleting a Route

- 1 On the remote control, select  > **Routes**.

A list of the ten closest routes is shown.

- 2 Select a route.

- 3 Select **Delete**.

## Tracks

A track is a recording of the path of your boat. The track currently being recorded is called the active track, and it can be saved. You can save up to 50 tracks.

When you connect the trolling motor to a chartplotter, the active track and saved tracks stored on the chartplotter are synchronized with the active track and saved tracks stored on the trolling motor. Adding, deleting, or editing active and saved tracks on one device automatically changes the active and saved tracks stored on the other device.

## Saving the Active Track

The track currently being recorded is called the active track. You can save the active track and navigate it later. You can save up to 50 tracks on the trolling motor.

- 1 On the remote control, select  > **Tracks** > **Save Active Track**.

The active track is saved with the current date as the track name.

- 2 Change the name for the saved track (optional).

## Clearing the Active Track

Select  > **Tracks** > **Clear Active Track**.

The track memory is cleared, and the active track continues to be recorded.

## Navigating to the Start of the Active Track

The track currently being recorded is called the active track. You can navigate from your current position back to the starting point of the active track along the path you traveled.

- 1 Select  > **Tracks** > **Backtrack**.

- 2 Turn on the propeller (*Turning the Propeller On and Off, page 16*).

The trolling motor navigates back to the starting point of the active track along the path you traveled (*Navigating, page 23*).

## Navigating a Saved Track

- 1 Select  > **Tracks** > **Saved Tracks**.

A list of the ten closest saved tracks is shown.

- 2 Select a saved track.

- 3 Select **Navigate To**.

- 4 Select an option:

- To navigate the saved track from the beginning of the track to the end, select **Forward**.
- To navigate the saved track from the end of the track back to the beginning, select **Backward**.

- 5 Turn on the propeller (*Turning the Propeller On and Off, page 16*).

The trolling motor drives along the saved track in the chosen direction (*Navigating, page 23*).

## Viewing Saved Track Details

- 1 On the remote control, select  > **Tracks** > **Saved Tracks**.

A list of the ten closest saved tracks is shown.

- 2 Select a saved track.

- 3 Select **Review**.

## Editing a Saved Track Name

- 1 On the remote control, select  > **Tracks** > **Saved Tracks**.

A list of the ten closest saved tracks is shown.

- 2 Select a saved track.

- 3 Select **Edit**.

- 4 Enter a new name for the saved track.

## Deleting a Saved Track

- 1 On the remote control, select  > **Tracks** > **Saved Tracks**.

A list of the ten closest saved tracks is shown.

- 2 Select a saved track.

- 3 Select **Delete**.

# Autopilot

## ⚠ WARNING

You are responsible for the safe and prudent operation of your vessel. The autopilot features on the trolling motor are tools that enhance your capability to operate your boat. They do not relieve you of the responsibility of safely operating your boat. Avoid navigational hazards and never leave the motor controls unattended.

Before activating any autopilot function, make sure the motor is fully in the deployed position, and the mount latch is engaged. Activating an autopilot function before the motor is latched in the deployed may lead to unexpected kayak movement, resulting in possible serious personal injury or property damage.

Learn to operate the autopilot features on calm and hazard-free open water.

## ⚠ CAUTION

When using the autopilot features, be prepared for sudden stops, acceleration, and turns.

The Force Current trolling motor supports autopilot features such as following a pre-planned route, maintaining your kayak's heading, and holding your position.

You must calibrate the trolling motor compass before you can use the autopilot features (*Calibrating the Trolling Motor Compass*, page 21). You must have a GPS signal to activate an autopilot mode (*Acquiring a GPS Signal*, page 22).

You can activate and control autopilot modes using the remote control (*Remote Control*, page 11), the Power Steer foot pedals (*Using the Foot Pedal Levers*, page 32), a chartplotter, a mobile device with the ActiveCaptain app, or a compatible Garmin watch. See the *Owner's Manual* at [garmin.com/manuals/force\\_current\\_trolling\\_motor](http://garmin.com/manuals/force_current_trolling_motor) for more information on autopilot features.

**TIP:** In some situations, the autopilot modes can create more turbulence than expected. You can adjust the autopilot gain settings to tailor the autopilot sensitivity to different conditions (*Adjusting the Autopilot Response*, page 22).

The Force Current supports the following autopilot features:

**Cruise Control:** The motor automatically controls the propeller speed to maintain a target speed (*Maintaining Your Speed*, page 22).

**Anchor Lock:** The motor automatically steers and runs the propeller to maintain your position (*Holding Your Position*, page 22).

**Heading Hold:** The motor steers automatically to keep your boat in the same heading (*Maintaining Your Heading*, page 23).

**Route Following:** The motor can steer and run the propeller automatically to navigate to a waypoint or along a course or a track (*Navigating*, page 23).

## Calibrating the Trolling Motor Compass

Before calibrating the trolling motor compass, you must move to an open area of calm water, with enough space to maneuver the kayak in a circle.

## NOTICE

Calibrating the trolling motor compass in rough water and wind conditions may negatively affect autopilot performance.

- 1 Make sure the trolling motor is in the deployed position (*Deploying the Motor*, page 6).
- 2 On the remote control, select  > **Settings** > **Trolling Motor** > **Calibrate** > **Compass**.
- 3 When prompted, follow the on-screen instructions to calibrate the compass.

## NOTICE

While calibrating the compass, you should use the trolling motor to steer the kayak at low speed. Using a paddle to steer the kayak to calibrate the compass may cause excessive movement, leading to poor autopilot performance.



If the autopilot features do not perform as expected, you should repeat the calibration process.

## Acquiring a GPS Signal

- 1 Move the kayak to an area with an unobstructed view of the sky.
- 2 Wait 30 to 60 seconds while the trolling motor locates satellites.  
When the motor has acquired a position using GPS, the  LED indicator light is solid green.

## Adjusting the Autopilot Response

You can adjust the autopilot gain setting to tailor the autopilot sensitivity to different conditions.

- 1 On the remote control, select  > **Settings** > **Trolling Motor**.
- 2 Select an option:
  - To adjust the gain for Anchor Lock mode, select **Anchor Gain**.
  - To adjust the autopilot gain for navigation modes, including Heading Hold and Cruise Control, select **Navigation Gain**.
- 3 Select  or  to increase or decrease the gain value:
  - Increase the gain setting to make the autopilot more responsive. The motor will be more accurate in controlling your kayak, but it may create more turbulence. Higher gain values are typically needed for larger or heavier boats.
  - Decrease the gain setting to make the autopilot less responsive. The motor will create less turbulence, but it may be less accurate in controlling your kayak.

## Maintaining Your Speed

Before you can use autopilot features, you must calibrate the trolling motor ([Calibrating the Trolling Motor Compass, page 21](#)).

The cruise control feature is an autopilot function that sets and maintains a specific speed over ground, adjusting for changes in current and wind automatically.

**TIP:** You can use cruise control alongside other autopilot modes ([Autopilot, page 21](#)).

On the remote control, press .

Cruise control is enabled at the present speed.

To turn off cruise control and turn off the propeller, you must press .

## Holding Your Position

Before you can use autopilot features, you must calibrate the trolling motor ([Calibrating the Trolling Motor Compass, page 21](#)).

The anchor lock feature uses GPS to maintain your position using the trolling motor.

Press .

**NOTE:** You can adjust the anchor lock position by pressing an arrow key on the remote control, or by using gesture controls ([Using Gesture Controls to Adjust Your Held Position, page 14](#)).

To disable anchor lock, press  again.



## Maintaining Your Heading

Before you can use autopilot features, you must calibrate the trolling motor ([Calibrating the Trolling Motor Compass, page 21](#)).



You can activate Heading Hold to keep your boat moving in the same compass direction. The motor may adjust your heading automatically to compensate for drift caused by factors such as wind and currents.

1 Steer the boat in the direction you want to go.

2 Press .

**NOTE:** You can adjust the direction by pressing  and , or by using gesture controls ([Gesture Controls, page 14](#)).

**TIP:** While using this autopilot mode, you can also maintain your speed using cruise control ([Maintaining Your Speed, page 22](#)).

To disable Heading Hold and return to manual mode, you must select  or .

## Changing the Heading Hold Behavior

By default, the Heading Hold feature is set to Go To mode, which may adjust your heading to compensate for drift and keep your boat moving in the same direction. If preferred, you can configure the Heading Hold feature to use Vessel Align mode, which ignores drift and simply keeps the bow of your boat pointing in the same direction.

1 On the remote control, select  > **Settings** > **Trolling Motor** > **Heading Hold**.

2 Select **Vessel Align**.

You can select Go To to revert back to the default Heading Hold behavior.

## Navigating

Before you can use autopilot features, you must calibrate the trolling motor ([Calibrating the Trolling Motor Compass, page 21](#)).

The trolling motor uses GPS to steer the boat to a waypoint location or to follow a route or a track.

1 On the remote control, select an option:

- Begin navigating to a saved waypoint ([Navigating to a Waypoint, page 18](#)).
- Begin navigating a saved route ([Navigating a Route, page 19](#)).
- Begin retracing the active track ([Navigating to the Start of the Active Track, page 20](#)).
- Begin navigating a saved track ([Navigating a Saved Track, page 20](#)).

**NOTE:** You can also use the trolling motor to follow autoguidance paths when navigation is started from a connected chartplotter. See your chartplotter owner's manual for more information.



Navigating is shown on the remote control screen, and the trolling motor automatically steers the boat to the destination.

2 Adjust the speed as needed.

**TIP:** While using this autopilot mode, you can also maintain your speed using cruise control ([Maintaining Your Speed, page 22](#)).

## Pausing and Resuming Navigation

1 While navigating, on the remote control, select an option:

- To pause navigation while continuing in the same direction at the same speed, select  > **Standby**.
- To pause navigation and set anchor lock, select 

Navigation stops, and the trolling motor returns to manual mode or maintains your position in anchor lock.

2 Select  > **Follow Route** or press  to resume navigation.

3 If necessary, start the propeller.

## Stopping Navigation

Select  > **Stop Nav.**

Navigation stops, and the trolling motor returns to manual mode.

# Settings

## Trolling Motor Settings

On the remote control, select  > **Settings** > **Trolling Motor**.

**Wi-Fi:** Sets the wireless network preferences for the trolling motor ([Wireless Network Settings, page 24](#)).

**Calibrate:** Calibrates the trolling motor compass ([Calibrating the Trolling Motor Compass, page 21](#)) and sets the trolling motor bow offset.

**Steering Mode:** Defines how the Power Steer foot pedals steer the boat ([Inverting the Steering Response, page 32](#)).

**MOB Tag Override Mode:** Turn on to allow the propeller to run even when the motor has lost connection with the MOB tag ([Overriding the MOB Tag, page 27](#)).

**Programmable Keys:** Redefines the function of the levers on the Power Steer foot pedals ([Changing the Function of the Foot Pedal Levers, page 32](#)).

**Units:** Sets the units of measure.

**Battery Management:** Defines settings related to the trolling motor battery ([Battery Management Settings, page 25](#)).

**Beeper:** Disables or enables the autopilot notification beeps.

**Auto Power On:** Turns on the trolling motor when you apply power to the system.

**Heading Hold:** Sets the behavior of the heading hold feature ([Changing the Heading Hold Behavior, page 23](#)).

**Nav. Arrival:** Sets the behavior of the trolling motor when you reach the end of a route. With the Anchor Lock setting, the trolling motor holds the position using the anchor lock feature when the boat reaches the end of the route. With the Manual setting, the propeller turns off when the boat reaches the end of the route.

### CAUTION

When using Manual for the Nav. Arrival setting, you must be ready to take control of the boat.

**Anchor Gain:** Sets the level of autopilot response when in anchor lock mode ([Adjusting the Autopilot Response, page 22](#)).

**Navigation Gain:** Sets the level of autopilot response when in other autopilot modes ([Adjusting the Autopilot Response, page 22](#)).

**Clear User Data:** Deletes all saved waypoints, routes, tracks, and your active track.

**NOTE:** If you are connected to a chartplotter, selecting this clears user data from both the trolling motor and the connected chartplotter.

**Restore Defaults:** Resets the trolling motor settings to the factory default values.

**NOTE:** Restoring default settings does not clear user data on the trolling motor or on a connected chartplotter.

## Wireless Network Settings

On the remote control, select  > **Settings** > **Trolling Motor** > **Wi-Fi**.

**NOTE:** The active Wi-Fi<sup>®</sup> mode is shown at the top of the screen.

**Mode:** Sets the Wi-Fi mode. You can turn off Wi-Fi technology, join the network of a chartplotter, or create a wireless access point to use the ActiveCaptain app ([Connecting to a Mobile Device with the ActiveCaptain App, page 33](#)).

**Setup > Name:** Sets the name of the wireless access point on the trolling motor (ActiveCaptain mode only).

**Setup > Password:** Sets the password for the wireless access point on the trolling motor (ActiveCaptain mode only).

## Battery Management Settings

On the remote control, select  > **Settings** > **Trolling Motor** > **Battery Management**.

**Indicator:** Sets the appearance of the trolling motor battery indicator to either an icon or a numeric voltage value.

**Battery Setup:** Sets the type of battery connected to the trolling motor, which helps calculate the reported battery status.

## Remote Control Settings

On the remote control, select  > **Settings** > **Remote Control**.

**Backlight:** Adjusts the backlight settings. ([Backlight Settings, page 25](#))

**Beeper:** Sets the beeper to sound for key presses and alarms.

**Auto Power Off:** Sets the length of time before the remote control turns off automatically.

**Calibrate:** Calibrates the remote control for the gesture-control features ([Calibrating the Remote Control, page 15](#)).

**Pairing:** Pairs the remote control with the trolling motor ([Pairing the Remote Control, page 15](#)).

**Language:** Sets the on-screen text language.

**Restore Defaults:** Resets the remote control to factory default settings. This restores the default configuration settings on the remote control, but does not remove saved user data.

## Backlight Settings

On the remote control, select  > **Settings** > **Remote Control** > **Backlight**.

**Keys:** Sets the backlight to turn on when a key is pressed.

**Alarms:** Sets the backlight to turn on when an alarm sounds on the remote control.

**Timeout:** Sets the length of time before the backlight turns off.

**Brightness:** Sets the brightness level of the backlight.



# MOB Tag

The Man Overboard (MOB) tag is an included accessory intended to help ensure your safety when you leave the kayak. When the MOB tag is turned on and paired to the trolling motor, the propeller automatically stops when the MOB tag is submerged.

## ⚠ WARNING

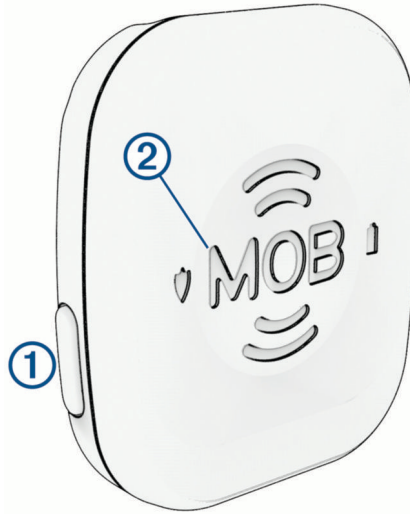
You must wear the MOB tag on your body and make sure it is turned on and paired with the trolling motor for the MOB automatic motor cut-off feature to work as expected. If the MOB tag is not powered on, paired and attached to your body, or if the MOB tag is not submerged, the trolling motor does not automatically stop the propeller. Leaving the kayak while the propeller is running may lead to serious personal injury or death.



<b>1</b>	<p>Power and interface button:</p> <ul style="list-style-type: none"><li>• Press to check the status and battery level of the tag.</li><li>• Hold to turn the tag on or off.</li></ul>
	<p>MOB button:</p> <ul style="list-style-type: none"><li>• Hold to stop the propeller.</li><li>• After returning to the kayak, press to clear the MOB status and resume normal operation of the motor.</li></ul>
<b>2</b>	<p><b>⚠ WARNING</b></p> <p>You must make sure the area around the trolling motor is clear before resuming normal operation of the motor. Resuming normal operation while others are near the trolling motor could result in serious personal injury or death.</p> <p><b>TIP:</b> You can also clear the MOB status by pressing the MOB OVERRIDE on the trolling motor or by dismissing the status message on the remote control or on a connected chartplotter.</p>
	<p>When you press the power button, the LED color indicates the connection status of the tag:</p> <ul style="list-style-type: none"><li>• Green: connected.</li><li>• Red: not connected.</li></ul>
	<p>When you press the power button, the LED color indicates the battery status of the tag:</p> <ul style="list-style-type: none"><li>• Green: the battery level is high.</li><li>• Orange: the battery level is medium.</li><li>• Red: the battery level is low.</li></ul>

## Attaching the Band or Carabiner Loop

The MOB tag is packaged with a carabiner loop, a wristband, and a floating keytag. You can use the carabiner loop to attach the MOB tag to your clothing, or you can attach the MOB tag to the wristband to wear it on your wrist. You can also attach the floating keytag to the carabiner or to the wristband to prevent the MOB tag from sinking if it is accidentally lost in the water. Follow these steps to attach the wristband or the carabiner loop to the MOB tag.

- 1 Insert one end of the spring bar on the band or carabiner loop into one of the holes on the MOB tag.
- 2 Slide the quick-release pin to retract the other end of the spring pin.

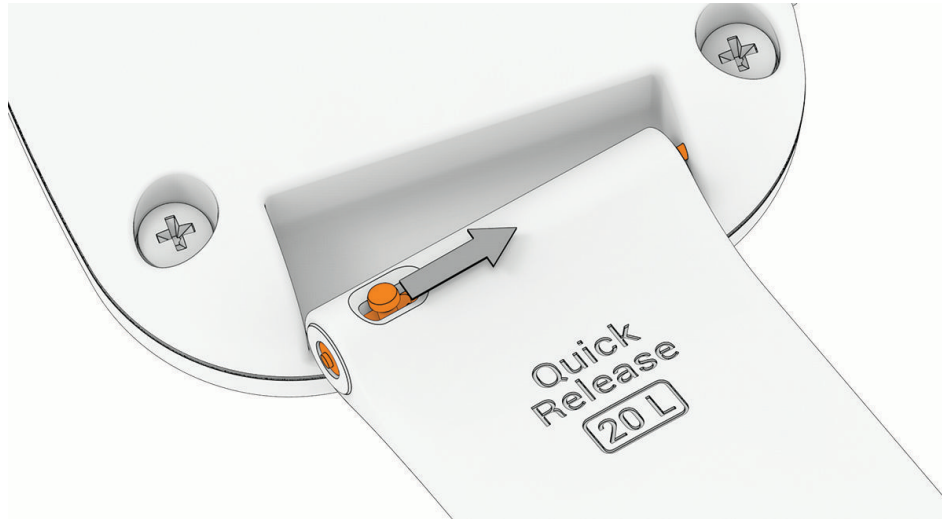

- 3 Align the spring bar with the other hole in the MOB tag, and release the pin.

## Overriding the MOB Tag

If the trolling motor loses its connection to the MOB tag, but you have not left the kayak, you can override the MOB function to temporarily resume normal operation.

### WARNING

You must make sure the area around the trolling motor is clear before resuming normal operation of the motor. Resuming normal operation while others are near the trolling motor could result in serious personal injury or death.

After the motor has lost its connection with the MOB tag, and the propeller has stopped, select an option:





- On the trolling motor remote, select  > **Settings > Trolling Motor > MOB Tag Override Mode.**
- Hold the MOB OVERRIDE button on the top of the trolling motor housing for five seconds.

The trolling motor emits a long beep when you turn MOB Tag Override Mode on or off. The trolling motor beeps periodically, and the  status LED flashes yellow when MOB Tag Override Mode is on.

If you recover the MOB tag and its connection to the trolling motor is restored, the trolling motor automatically turns off MOB Tag Override Mode. To resume normal operation, you must press the MOB button on the MOB tag, or dismiss the MOB message on the remote control or a connected chartplotter.

## Pairing an MOB Tag with the Force Current Trolling Motor

The MOB tag included with the Force Current trolling motor is paired with the trolling motor at the factory. Follow the steps to pair a new MOB tag with the trolling motor.

- 1 Make sure the trolling motor is turned on.
- 2 Hold the power button on the side of the MOB tag to turn it on.  
The  icon on the MOB tag flashes red.
- 3 On the trolling motor, press  three times.  
The  LED indicator flashes blue as the motor searches for a connection.
- 4 Make sure the MOB tag is within 1 m (3 ft.) of the trolling motor.
- 5 Press the power button on the MOB tag three times quickly.  
The  icon on the MOB tag flashes blue as it searches for a connection.

When the connection is successful, the  status LED on the trolling motor turns solid green.

## Replacing the MOB Tag Battery

### ⚠ WARNING

See the *Important Safety and Product Information* guide in the product box for product warnings and other important information.

- 1 Using a #1 Phillips screwdriver, loosen the four captive screws to remove the back cover.



- 2 Gently lift the white tab to release the battery from the back cover.
- 3 Place the new battery in the back cover, with the positive (+) side down.
- 4 Make sure the rubber gasket in the front cover of the MOB tag is not broken and is fully seated in its groove. The gasket fits in the groove in a specific orientation.

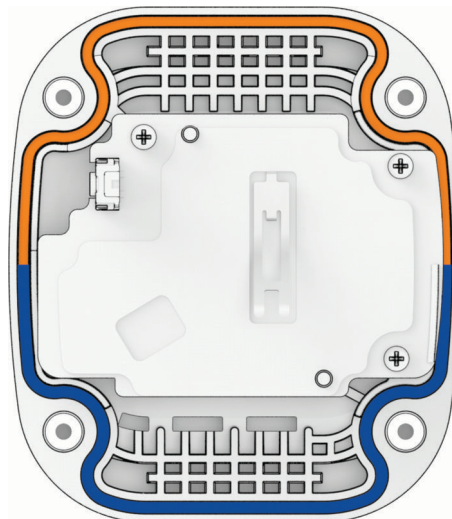

### NOTICE

If the gasket is not properly and fully seated in the groove, it does not create a seal, which leads to the failure of the MOB tag when it is exposed to water. See the *Field Service Manual* at [garmin.com/manuals/force\\_current\\_trolling\\_motor](http://garmin.com/manuals/force_current_trolling_motor) for information on purchasing a replacement gasket.

After you replace the battery, you may need to pair the MOB tag again (*Pairing an MOB Tag with the Force Current Trolling Motor*, page 28).

## Power Steer Foot Pedals

The Power Steer Foot Pedals are an optional accessory included with some models.

## Attaching the Pedals to the Rails

- 1 Align the screw on the outside of the pedal with the threaded socket in the pedal carriage on the rail, and turn the knob on the other side of the pedal, clockwise, to attach the pedal to the pedal carriage.

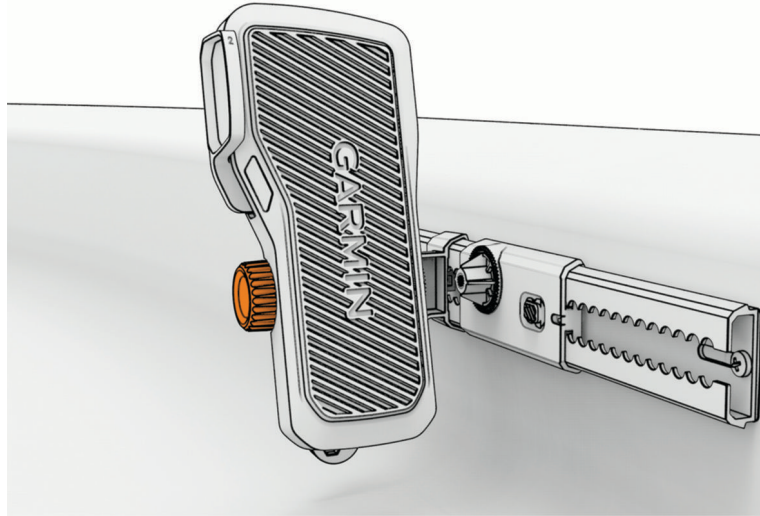

- 2 Tilt the pedal back and forth to check its range of motion, and adjust the angle of the pedal if necessary.
- 3 If necessary, push the button on the pedal carriage and slide it along the rail to position the pedal at a comfortable distance.

### NOTICE

Do not move the pedal carriages all the way to either end of the pedal rail. If the pedal carriage overlaps one of the pedal rail mounting screws, it may become difficult to move it.

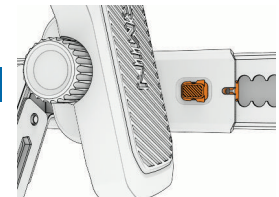

- 4 Repeat the steps for the other pedal.

**TIP:** You can check the marks where the pedals connect to the pedal carriages to make sure both pedals are installed at the same angle.

### NOTICE

You must remove the pedals from the pedal carriages before transporting the kayak. The pedals may become loose during transport, which could cause property damage.

## Steering with the Foot Pedals

### ⚠ WARNING

Learn to operate the foot pedals on calm and hazard-free open water. Start with small movements until you get comfortable with the pedal response.

You can tilt each pedal forward or back from a neutral position. As you tilt the pedals further in either direction, the propeller spins faster. The combined position of both pedals determines the angle of the propeller drive motor.

- To move forward, tilt both pedals forward.
- To move backward, tilt both pedals back.

### ⚠ WARNING

When using the trolling motor to drive your kayak backward, the kayak may steer unexpectedly, due to the hull interfering with the motor thrust. You must stay alert and aware of your surroundings when using the motor to move your kayak backward, to avoid possible personal injury or product damage caused by an accidental collision.

- To turn left, tilt the right-side pedal forward while keeping the left-side pedal in the neutral position.

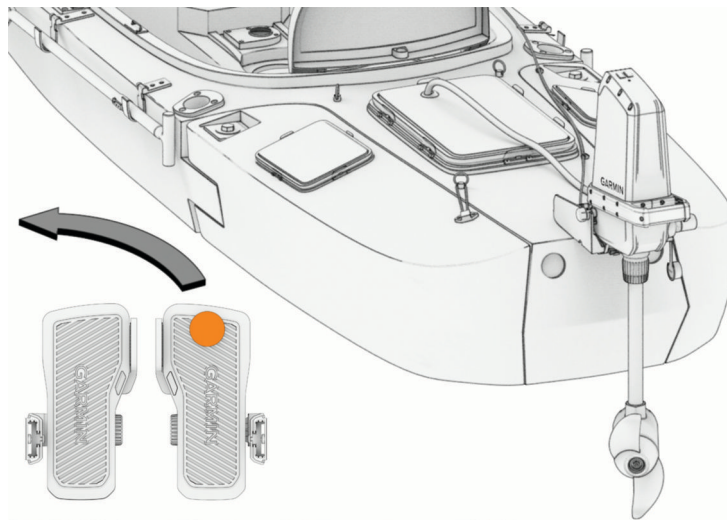

The nose of the propeller drive motor turns to the right, turning the kayak to the left.

- To turn right, tilt the left-side pedal forward while keeping the right-side pedal in the neutral position.

The nose of the propeller drive motor turns to the left, turning the kayak to the right.

- To turn your kayak at a sharper angle, tilt one pedal forward while you tilt the other pedal back.

The nose of the propeller drive motor turns to up to 90 degrees, depending on the relative angle of each pedal.

**NOTE:** At steering angles greater than 45 degrees, the propeller drive speed is automatically limited to reduce turbulence.

You can invert the right and left pedal response to emulate steering with a cable-controlled rudder instead ([Inverting the Steering Response, page 32](#)).

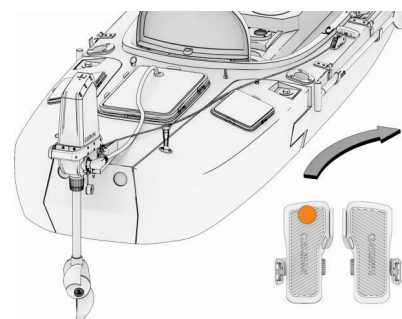

## Inverting the Steering Response

By default, the Power Steer foot pedals emulate differential steering, such as that of a zero-turn lawn mower. You can invert the right and left pedal response to emulate steering with a cable-controlled rudder instead.

- 1 On the remote control, select  > **Settings** > **Trolling Motor** > **Steering Mode**.
- 2 Select **Rudder**.

You can select Zero-Turn to revert to the default steering mode.

## Using the Foot Pedal Levers

You can use the levers on each of the foot pedals to activate autopilot modes.

- To turn **Heading Hold** on or off, push the lever on the left pedal.
- To turn **Anchor Lock** on or off, push the lever on the right pedal.

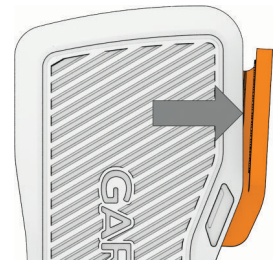



## Changing the Function of the Foot Pedal Levers

- 1 On the remote control, select  > **Settings** > **Trolling Motor** > **Programmable Keys**.
- 2 Select an option:
  - To configure the lever on the right pedal, select **Right Pedal**.
  - To configure the lever on the left pedal, select **Left Pedal**.
- 3 Select an option:
  - To disable the foot pedal lever, select **None**.
  - To turn Anchor Lock on or off when you push the pedal lever, select **Anchor Lock**.
  - To turn Heading Hold on or off when you push the pedal lever, select **Heading Hold**.
  - To mark a waypoint at your present location when you push the pedal lever, select **Mark Waypoint**.

## Pairing the Foot Pedals

If the foot pedals were included with the trolling motor, they are paired with the trolling motor at the factory. Follow these steps to pair a new set of foot pedals.

You must pair each pedal separately.

- 1 Make sure the trolling motor is turned on.
- 2 On the trolling motor, press  three times to enter pairing mode.  
The  LED indicator flashes blue as it searches for a connection.
- 3 Bring a foot pedal within 1 m (3 ft.) of the trolling motor.
- 4 Push the lever on the foot pedal three times.

The LED indicator light on the foot pedal flashes blue as it searches for a connection, and turns solid green when the connection is successful.

- 5 Repeat steps 2 through 4 to pair the other foot pedal.

**TIP:** As a test, when pressing on the pedal lever, the LED indicator light flashes green to indicate that the pedal is paired to the motor, or it flashes red to indicate that it is not paired.

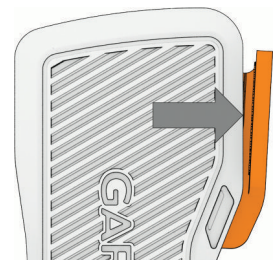

## Installing Batteries in the Foot Pedals

Each foot pedal operates using two AA batteries (not included). Use lithium batteries for the best results.

**TIP:** You can press the pedal lever two times to test the level. The LED indicator light on the pedal turns solid green, yellow, or red to indicate the general battery level.

- 1 On a foot pedal, turn the D-ring counter-clockwise, and pull up to remove the cover.
- 2 Insert two AA batteries, observing polarity.
- 3 Replace the battery cover, and turn the D-ring clockwise.
- 4 Repeat these steps for the other pedal.

## Status LED

The LED on each Power Steer foot pedal illuminates to indicate the status of the pedal.

Green	The foot pedal is connected to the trolling motor, and a lever command was activated.
Blue	The foot pedal is in pairing mode.
White	The foot pedal is connected and was moved to the neutral position.
Purple	The foot pedal is installing a software update. <b>NOTICE</b> You must not remove power to the foot pedal when the software is updating, or it may damage the pedal.
Red	The foot pedal lever was activated, but the pedal is not connected to the trolling motor.

## Connecting to a Mobile Device with the ActiveCaptain App



You can connect a mobile device to the trolling motor using the ActiveCaptain app. The app provides a quick and easy way for you to interact with your trolling motor and update the device software.

- 1 On the remote control, select  > **Settings** > **Trolling Motor** > **Wi-Fi** > **Mode** > **ActiveCaptain** > **Setup**.
- 2 Enter a name and password for this network.
- 3 From the application store on your mobile device, install and open the ActiveCaptain app.
- 4 Bring the mobile device near the trolling motor.
- 5 From your mobile device settings, open the Wi-Fi connections page and connect to the trolling motor, using the name and password you entered in the previous step.

## Connecting to a Chartplotter

Your compatible Garmin chartplotter must have the latest software version installed before you can connect the trolling motor.



You can connect the trolling motor wirelessly to a compatible Garmin chartplotter. After you connect to a compatible chartplotter, you can control the trolling motor from the chartplotter.

- 1 Turn on the chartplotter and the trolling motor.
- 2 Make sure that the chartplotter is hosting a wireless network.  
**NOTE:** If you have multiple chartplotters installed, only one is the wireless network host. Consult your chartplotter's owner's manual for more information.
- 3 On the chartplotter, select **Settings > Communications > Wireless Devices > Garmin Trolling Motor > Start**.
- 4 On the trolling motor display panel, press  three times to enter pairing mode.  
The  LED indicator light on the trolling motor illuminates blue as it searches for a connection to the chartplotter, and changes to green when the connection is successful.  
A confirmation message appears on the chartplotter when the connection is successful.
- 5 After the chartplotter and trolling motor connect successfully, enable the trolling motor bar on the chartplotter to control the motor.  
See the latest version of your chartplotter's owner's manual for complete operation instructions.

## Connecting to a Garmin Watch

You can connect the trolling motor wirelessly to a compatible Garmin watch, and control the trolling motor using the Trolling Motor app on the watch.

The first time you connect the trolling motor to your watch, you must pair the watch and the motor. After they are paired, the watch connects to the motor automatically when the motor is powered on and within range.

- 1 Make sure the trolling motor is powered on and a remote control is connected to it.
- 2 Bring your compatible Garmin watch within 3 m (10 ft.) of the trolling motor.
- 3 On the watch, hold **MENU**.
- 4 Select **Sensors & Accessories > Add New > Trolling Motor**.
- 5 On the trolling motor display panel, press  three times to enter pairing mode.  
 on the trolling motor display panel is solid blue as it searches for a connection, and changes to solid green when the connection is successful.
- 6 Confirm the pairing code shown on the watch and on the connected remote control.

You can press **START** and select Trolling Motor from the list of activities and apps to open the trolling motor controls.

## Software Updates

You can go to [garmin.com/support/software/marine/](https://garmin.com/support/software/marine/) to find information on the latest software updates for your Garmin marine devices.

# Maintenance Needs and Schedule

## NOTICE

After using the motor in salt water or brackish water, you should rinse off the entire motor with fresh water, and apply a water-based silicone spray using a soft cloth. You must avoid spraying jets of water at the motor, to prevent water ingress that could lead to product damage.

To maintain your warranty, you must perform routine maintenance tasks to prepare your motor for the season.

For the Force Current trolling motor:

- Check the end of the pull rope under the mount latch, and tie a new stopper knot if necessary.
- Check the movement of the mount latch. If it does not spring back smoothly, clean and lubricate the mount latch.
- Check the end of the pull rope in the pull handle, and tie a new stopper knot if necessary.
- Check the rope pulleys in the motor mount and in the cleat and make sure they rotate freely. Clean or replace any damaged part if necessary.
- Check the pull handle, and replace it if there are cracks or other signs of wear.
- Check the entire length of the pull rope for fraying or other signs of wear. Replace it if necessary.
- Check the pad eyes and the cleat. Tighten the mounting screws if necessary. Replace the pad eyes and the cleat if there are cracks or other signs of wear on them.
- Check the screws securing the mount to the kayak. Tighten or replace them if necessary.
- Check the mounting surface around the mount. If there are signs of wear, consider reinforcing the mounting surface and reinstalling the mount.
- Check the motor mount, and replace it if there are cracks or other signs of damage.
- Check the motor pivot knobs, and replace them if there are cracks or other signs of damage.
- Check the entire length of the power cable for wear, and replace it if necessary.
- Check the power cable connector for corrosion or bent sockets. Clean or replace the cable if necessary.
- Check the power connector cover on the motor to make sure it fits correctly to protect the power connector. Replace the connector cover if necessary.
- Check the anodes on the propeller drive motor, and replace them if necessary (*Checking the Sacrificial Anodes, page 37*).
- Check the propeller to make sure the propeller nut is tightened to 16.27 N-m (12 lbf-ft.).
- Check the propeller for wear. Replace it if necessary (*Changing the Propeller, page 10*).

For the Power Steer foot pedals:

- Check the screws securing the pedal rails to the kayak. Tighten if necessary.
- Check the battery compartment in the foot pedals to make sure the batteries have not ruptured. Clean the battery contacts if necessary.

You can order the most common replacement parts and accessories at [garmin.com/accessories/force\\_current\\_trolling\\_motor](https://garmin.com/accessories/force_current_trolling_motor). For service instructions and information on other replacement parts, see the *Field Service Manual* on [garmin.com/manuals/force\\_current\\_trolling\\_motor](https://garmin.com/manuals/force_current_trolling_motor).

## Replacing the Pull Rope

- 1 Cut the worn or damaged rope and remove it from the motor and from the rope handle.
- 2 Feed one end of the new rope through the metallic release latch in the mount ①.

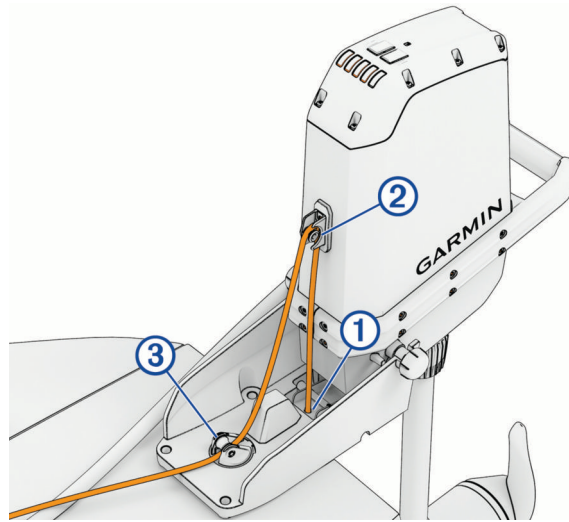

- 3 Tie the end of the new rope under the mount into a stopper knot to prevent the rope from pulling out through the release latch.
- 4 Feed the rope up through the eyelet on the front of the motor ②.
- 5 Guide the rope down and feed it through the swivel pulley on the mount ③.
- 6 Route the rope through the pad eyes and the cleat.
- 7 Install the rope handle on the new rope ([Installing the Rope Handle, page 36](#)).



## Installing the Rope Handle

- 1 Feed the end of the rope through the two pieces of the pull handle.
- 2 Trim the rope, allowing enough slack to make sure you can comfortably reach it from your position seated in your kayak.  
**TIP:** We recommend trimming the rope to about 20 cm (8 in.) from the cleat, so the pull handle will stay close to the cleat when the motor is in the deployed position.
- 3 Tie a stopper knot to bind the rope inside the pull handle.
- 4 If necessary, trim and melt the end of the rope to prevent fraying.
- 5 Snap the two pieces of the pull handle together.

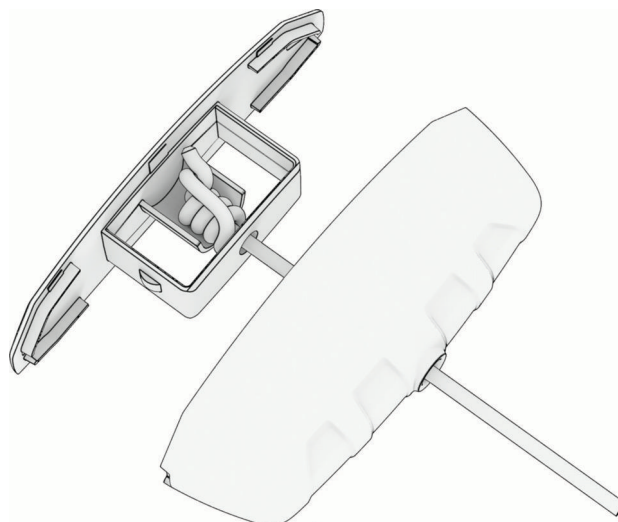

## Checking the Sacrificial Anodes

- 1 Using a  $\frac{9}{16}$  in. (15 mm) socket, loosen the nut on the end of the propeller.
- 2 Remove the propeller and set aside the nut, the lock washer, and the flat washer.
- 3 Remove and examine the propeller anode ①.

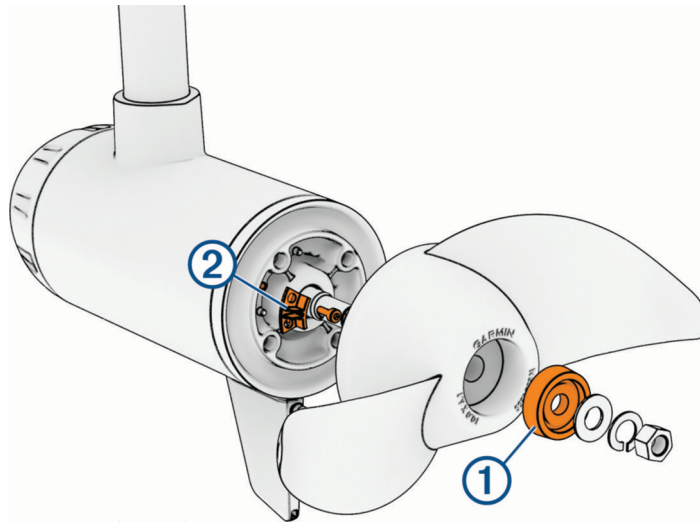

- 4 Using a 3 mm hex key, remove and examine the propeller drive anode ②.
- 5 Select an option:
  - If either anode is half of its original size or larger, clean it using a wire brush or sandpaper.

### NOTICE

You should remove the anode from the motor before cleaning it with a wire brush or sandpaper. Cleaning the anode while it is installed on the motor could damage the motor, accelerate corrosion, and shorten the life of the motor.

- If the anode is smaller than half of its original size, discard the anode and purchase a replacement.

You can purchase a set of replacement anodes at [garmin.com/accessories/force\\_current\\_trolling\\_motor](https://garmin.com/accessories/force_current_trolling_motor).

### NOTICE

When reinstalling the propeller on the propeller drive motor, you must tighten the propeller nut to 16.27 N-m (12 lbf-ft.) to secure it properly.

# Specifications

## Trolling Motor

Weight	Motor only: 10.1 kg (22.2 lbs) With mount and cable: 12.6 kg (27.8 lbs)
Operating temperature	From -5° to 40°C (from 32° to 104°F)
Storage temperature	From -40° to 85°C (-40° to 185°F)
Water rating	Steering system housing: IEC 60529 IPX7 <sup>6</sup> Propeller drive motor housing: IEC 60529 IPX8 <sup>7</sup>
Compass safe distance	91 cm (3 ft.)
Power cable length	165 cm (5 ft. 5 in.)
Input voltage	From 12 to 24 Vdc
Input amperage	40 A continuous
Breaker (not included)	32 VDC or greater, suitable for 40 A continuous <b>NOTE:</b> You can protect the system by using a larger circuit breaker, not to exceed 60 A, if you are operating under high temperatures or if you are sharing the circuit with other devices. You should verify that your boat wiring meets marine wiring standards using a larger breaker before changing it.
Maximum power consumption	420 W @ 12 Vdc 768 W @ 24 Vdc
Wireless frequency and transmit power	2.4 GHz @ 19.0 dBm maximum

<sup>6</sup> Withstands incidental exposure to water of up to 1 meter for up to 30 minutes.

<sup>7</sup> Withstands continuous immersion in water up to 3 meters deep.

## Dimensions

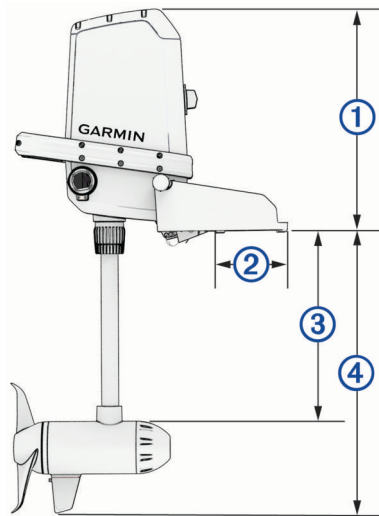

①	431 mm (17 in.)
②	29 mm (1 1/8 in.)
③	290 mm (11 3/8 in.) min. 422 mm (16 5/8 in.) max.
④	470 mm (18 1/2 in.) min. 602 mm (23 3/4 in.) max.

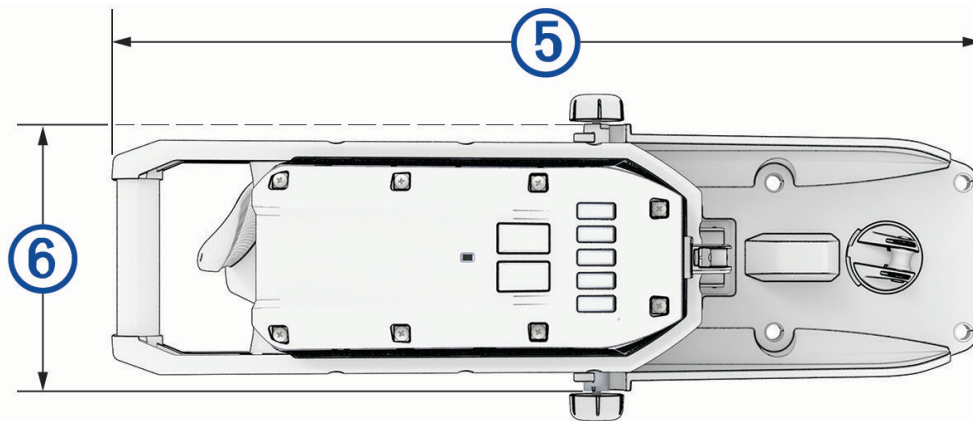

⑤	527 mm (20 3/4 in.)
⑥	185 mm (7 5/16 in.)

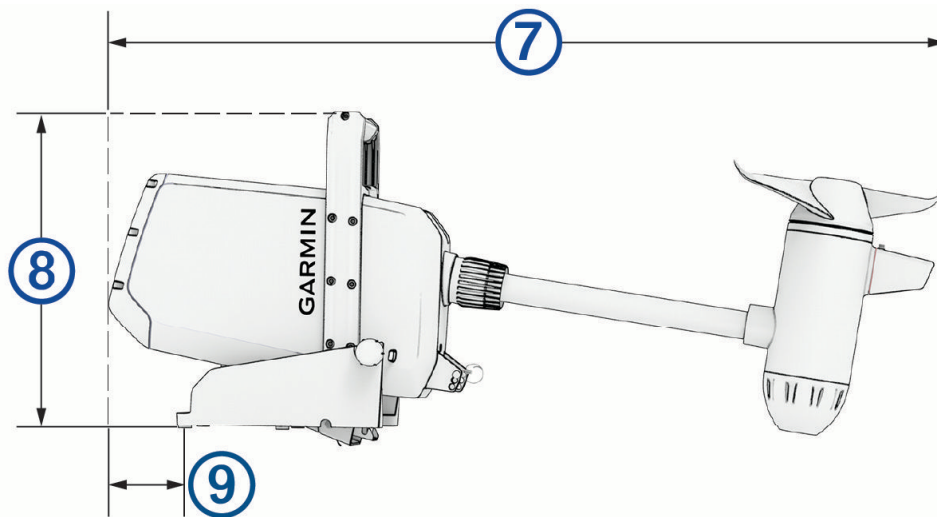

⑦	1005 mm (39 <sup>5</sup> / <sub>8</sub> in.)
⑧	385 mm (15 <sup>3</sup> / <sub>16</sub> in.)
⑨	112 mm (4 <sup>3</sup> / <sub>8</sub> in.)

## Power Steer Foot Pedals

The Power Steer foot pedals are only included with some models.

Weight (complete system, including rails)	3.08 kg (6.8 lb.)
Operating temperature	From -5° to 40°C (from 32° to 104°F)
Storage temperature	From -40° to 85°C (-40° to 185°F)
Water rating	IEC 60529 IPX7 <sup>8</sup>
Compass safe distance	61 cm (24 in.)
Power Supply	2 AA batteries per pedal
Wireless frequency and transmit power	2.4 GHz @ 9.1 dBm maximum

<sup>8</sup> Withstands incidental exposure to water of up to 1 meter for up to 30 minutes.

## Dimensions

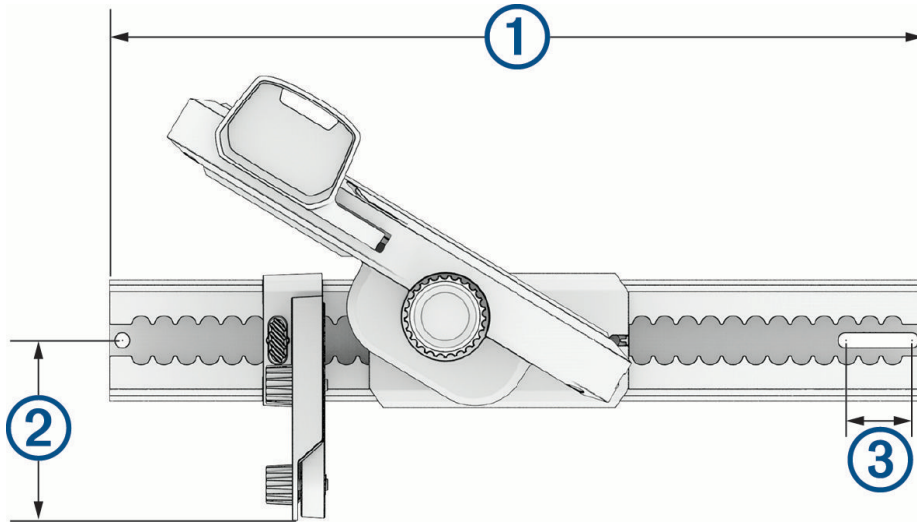

①	394 mm (15 1/2 in.)
②	87 mm (3 7/16 in.) minimum (short stabilizer arm) 196 mm (7 11/16 in.) maximum (long stabilizer arm)
③	32 mm (1 1/4 in.)

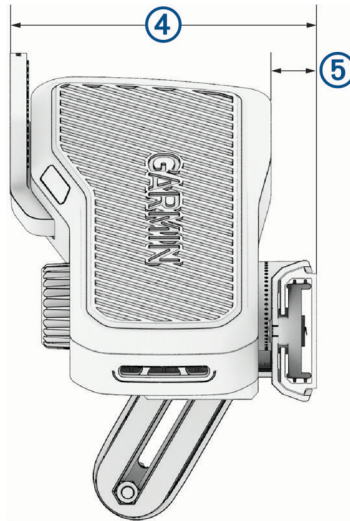

④	141 mm (5 9/16 in.)
⑤	21 mm (13/16 in.)

## Remote Control

Dimensions (W×H×D)	152 x 52 x 32 mm (6 x 2 x 1 <sup>1</sup> / <sub>4</sub> in.)
Weight	109 g (3.8 oz.) without batteries
Material	Glass-filled nylon
Display type	Sunlight-visible, transfective memory-in-pixel (MIP)
Display resolution	R240 x 240 pixels
Display size (diameter)	30.2 mm (1 <sup>3</sup> / <sub>16</sub> in.)
Operating temperature	From -15° to 55°C (5° to 131°F)
Storage temperature	From -40° to 85°C (-40° to 185°F)
Battery type	2 AA (not included)
Battery life	240 hr., typical use
Radio frequency	2.4 GHz @ 10.0 dBm nominal
Water rating	IEC 60529 IPX7 <sup>9</sup>
Compass-safe distance	15 cm (6 in.)

## MOB Tag

Weight	21.635g (black model) 21.222g (white model)
Battery type	CR2032 lithium coin cell
Operating temperature	From -15° to 60°C (from 5° to 140°F)
Compass-safe distance	5 cm (1.97 in.)
Water rating	IEC 60529 IPX8 (5 ATM) <sup>10</sup>
Wireless frequency and transmit power	2.4 GHz @ +8 dBm nominal

<sup>9</sup> Withstands incidental exposure of water up to 1 m for up to 30 min.

<sup>10</sup> Withstands incidental exposure to water up to 50 m for up to 30 min. For more information, go to [garmin.com/waterrating](https://www.garmin.com/waterrating)



