

# GARMIN®

## FORCE® AND FORCE PRO TROLLING MOTOR PULL HANDLE AND CABLE INSTRUCTIONS

### Important Information

#### ⚠ WARNING

See the *Important Safety and Product Information* guide in the product box for product warnings and other important information.

You can replace the pull cable without disassembling any part of the motor.

### Tools Needed

- #1 Phillips screwdriver
- Needle-nose pliers

### Removing the Pull Cable Handle

1 Transition the motor to the stowed position, and secure the safety strap.

#### ⚠ CAUTION

You must keep the motor in the stowed position with the safety strap secured until you have finished servicing your motor. If the mount is not securely locked in the stowed position while you work, it may shift and crush your hands or fingers.

2 Using a #1 Phillips screwdriver, loosen the two screws ① that secure the top of the handle.

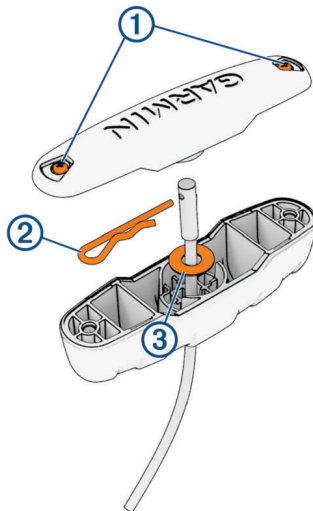

3 Push the pull cable up from the bottom of the handle, and remove the R-pin ②.

4 Pull the cable out through the washer ③ and the bottom of the handle.

## Removing the Pull Cable

- 1 Locate the access hole on the lower link, near the depth adjustment collar.
- 2 Using needle-nose pliers, remove the R-pin that secures the pull cable to the locking mechanism.

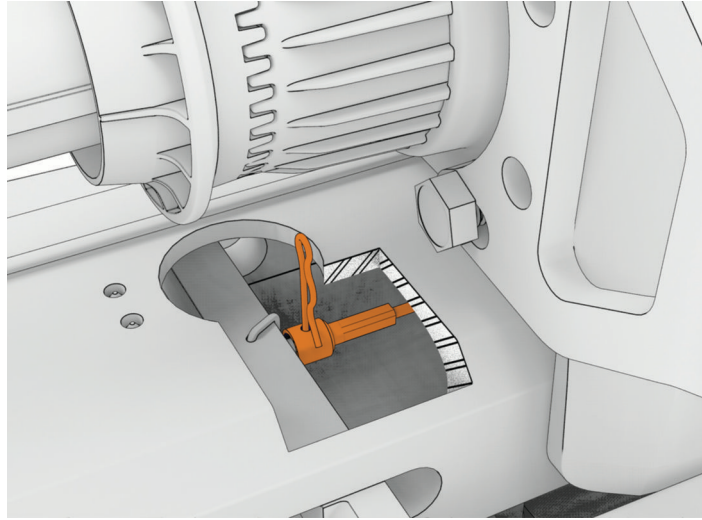

- 3 Remove the end of the pull cable through the access hole, and pull to remove the rest of the cable from the steering servo housing.

## Installing a New Pull Cable

### ⚠ CAUTION

You must keep the motor in the stowed position with the safety strap secured until you have finished servicing your motor. If the mount is not securely locked in the stowed position while you work, it may shift and crush your hands or fingers.

- 1 Feed the smaller end of the new pull cable into the access hole on the mount base and up through the steering servo.
- 2 Using your hand through the underside of the motor, guide the small end of the pull cable under the pivot pin and out through the hole on the top of the steering servo ①.

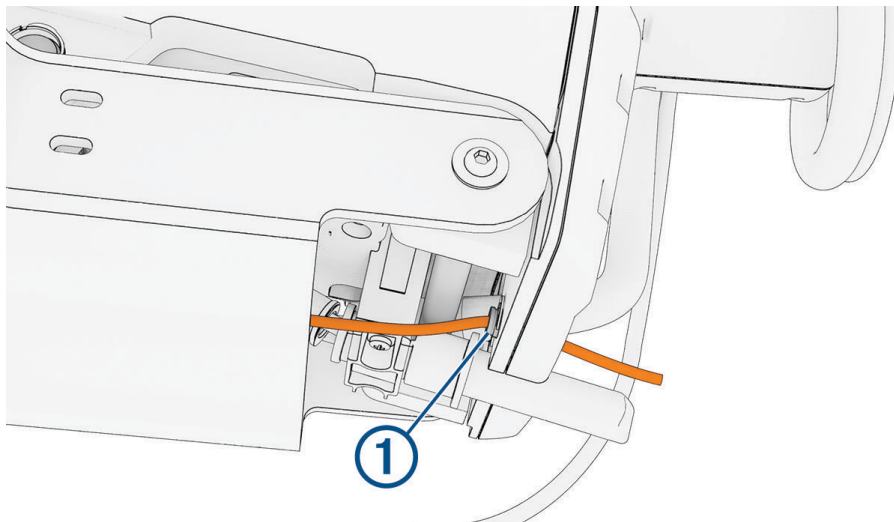

- 3 Pull the cable through until the larger end passes through the access hole.

- 4 Place the larger end of the cable over the stud in the access hole.
- 5 If necessary, rotate the cable to align the hole on the end of the cable with the hole on the stud, and push the R-pin through.  
**TIP:** You can use needle-nose pliers to push the R-pin, if necessary.

## Installing the Handle on the Pull Cable

### ⚠ CAUTION

You must install the included R-pin in the handle. Using an inadequate R-pin in the handle may cause a failure of the handle potentially leading to personal injury.

- 1 Insert the pull cable through the handle.

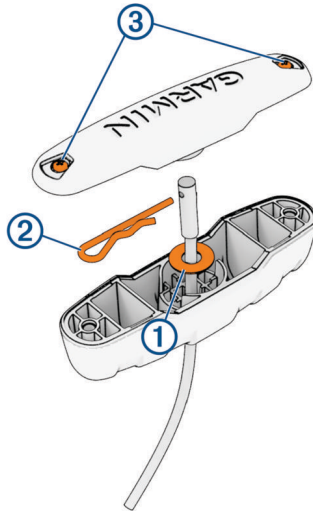

- 2 Insert the pull cable through the washer ①.
- 3 Push the R-pin ② through the hole on the end of the pull cable.
- 4 Pull the cable down so that the washer and R-pin rest fully in the handle.  
**NOTE:** If the washer and the R-pin are not fully seated in the handle, you will not be able to install the handle cover.
- 5 Place the handle cover on the handle and, using a #1 Phillips screwdriver, tighten the screws ③.

© 2019 Garmin Ltd. or its subsidiaries

