



TracPhone® V30 Installation Guide



TracPhone® V30 Installation Guide



This guide explains how to install the TracPhone V30 mini-VSAT Broadband satellite communications system. Operation instructions are provided in the Quick Start Guide.

Table of Contents

Important Safety Information.....	2	Set Up No-Transmit Zones (Optional).....	23
Inspect Parts and Get Tools.....	3	Test the System	24
Plan the Antenna Installation.....	4	Configure the Network.....	25
Plan the VSAT-Hub Installation.....	7	Connect the Vessel Phone.....	26
Prepare the Antenna Site	8	Educate the Customer	27
Prepare the Antenna Cable	9		
Wire the Antenna	10	Appendices	
Mount the Antenna.....	11	Terminating RG-58 Cable	28
Mount the VSAT-Hub	13	Wiring the Antenna Using a Preinstalled Cable	31
Wire the VSAT-Hub	14	Connecting Pigtail Cables to the Antenna Cable.....	32
Connect an NMEA Talker.....	15	Verifying the NMEA 0183 Message	33
Connect Power.....	16	Wiring Diagram	34
Turn On the System.....	18		
Set Up the System	19		

CAUTION - RF Radiation Hazard



The antenna transmits radio frequency (RF) energy that is potentially harmful. Whenever the system is powered on, make sure everyone stays more than 32 ft (10 m) away from the antenna within its 7.7-75° elevation range. No hazard exists directly above the antenna and anywhere below the antenna's mounting plane.

Who Should Install the System?

To ensure a safe and effective installation, KVH recommends that a KVH-authorized marine technician install the TracPhone V30 system. To find a technician near you, visit www.kvh.com/wheretogetservice.

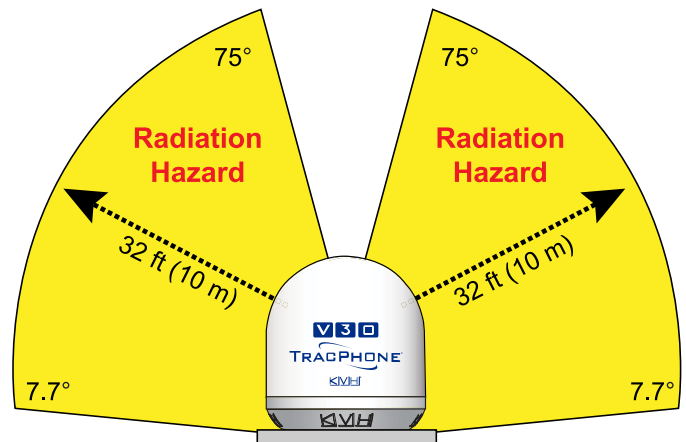

Technical Support

Within Continental U.S.A.: 1 866 701-7103
Worldwide: +1 401 851-3806
Email: mvbsupport@kvh.com

Trademark Information

KVH, TracPhone, and the unique light-colored dome with dark contrasting baseplate (Reg. No. 2,864,752) are registered trademarks, and mini-VSAT Broadband is a service mark, of KVH Industries, Inc.

All other trademarks are the property of their respective companies.

Disclaimer

Every effort has been made to ensure the correctness and completeness of the material in this document. No company shall be liable for errors contained herein. The information in this document is subject to change without notice. No warranty of any kind is made with regard to this material, including, but not limited to, the implied warranties of merchantability and fitness for a particular purpose.

Feedback

If you have any comments regarding this manual, please email them to manuals@kvh.com. Your input is greatly appreciated!

Important Safety Information



This icon indicates a danger, warning, or caution notice. Be sure to read these carefully to avoid injury.



WARNING Risk of Electric Shock

If any component of the TracPhone V30 system becomes damaged and/or no longer functions normally, disconnect it from vessel power, secure it from unintended operation, and contact KVH Technical Support (see “[Technical Support](#)” on page 1). All repairs or modifications must be performed by a trained, KVH-certified technician. If you are a KVH-certified technician, you still must contact KVH Technical Support prior to conducting any repairs or modifications to the equipment.



WARNING Risk of Explosion

Do not operate the VSAT-Hub (or any other electrical device) in an environment where flammable gases, vapors, or dusts are present. In addition, do not operate the VSAT-Hub in an environment with a temperature outside its 5° F to 131° F (-15° C to 55° C) temperature range.



CAUTION Risk of Electric Shock

Failure to ground the TracPhone V30 system properly to ship’s ground will cause an unsafe floating ground condition, risking potentially lethal electric shock. See “[Connect Power](#)” on page 16 for details on the proper grounding of the equipment.



CAUTION RF Radiation Hazard

The antenna transmits up to 3 watts of radio frequency (RF) energy that is potentially harmful. Whenever the system is powered on, make sure everyone stays more than 32 feet (10 m) away from the antenna. No hazard exists directly below the antenna.

Inspect Parts and Get Tools

Before you begin, follow these steps to ensure you have everything needed to complete the installation.

1. Unpack the box and ensure it contains everything shown in Figure 1 and on the Kitpack Contents List. Save the packaging for future use.

IMPORTANT!

Always lift the antenna by the baseplate and never by the radome or any portion of the internal antenna assembly.

2. Carefully examine all of the supplied parts to ensure nothing was damaged in shipment.
3. Gather the following tools and materials:
 - Flat-head and Phillips-head screwdrivers
 - Electric drill and 5/16" (8 mm) bit
 - 1.5" (38 mm) hole saw
 - 1/2" socket and 7/16" socket
 - Light hammer and center punch
 - Adhesive tape
 - Self-vulcanizing tape or equivalent
 - Heat gun (for heat shrink)
 - Eye protection
 - Shop towels
 - Voltmeter
 - Utility knife
 - Flush cutters
 - Wire stripper/terminal crimper
 - File
 - Wi-Fi-enabled laptop PC, or Apple® or Android™ smartphone/tablet with the latest software downloaded from the KVH Partner Portal (www.kvh.com/partners), or a smartphone/tablet with the KVH V30 app installed and loaded with the latest antenna software
 - Cable termination tools, if necessary (see [“Prepare the Antenna Cable”](#) on page 9)
 - NMEA 0183 or NMEA 2000 talker and interface cable (see [“Connect an NMEA Talker”](#) on page 15)

Figure 1: TracPhone V30 System Components

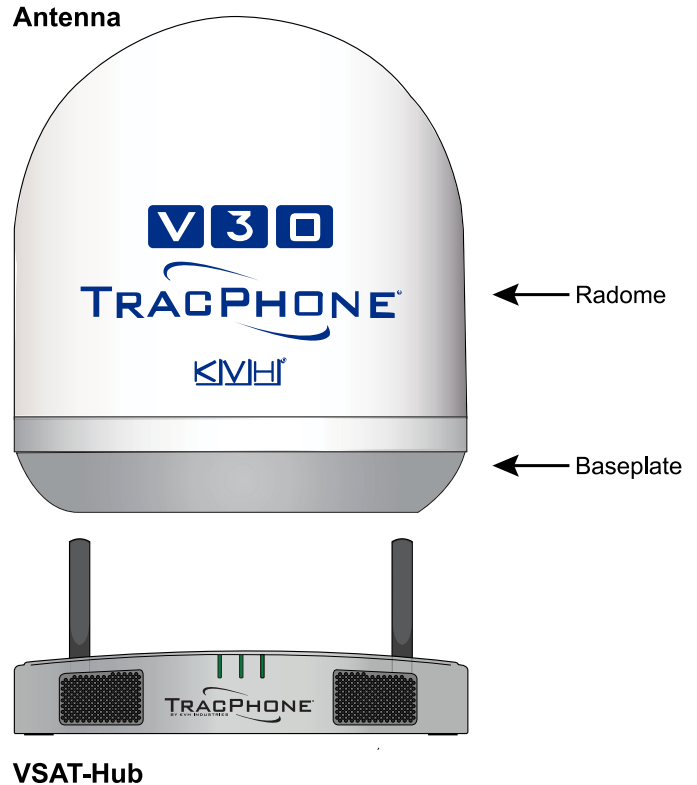

Plan the Antenna Installation

Before you begin, be sure the designated install location meets the following guidelines.

IMPORTANT!

Damage caused by an improper installation is not covered under KVH warranty.

Choose a Suitable Location

- Select a location that is as close as possible to the intersection of the vessel's centerline and midships.
- Temperature must be within the operating range (-30°C to 55°C (-22°F to 131°F)).
- Avoid placing the antenna near any magnetic compasses or other onboard antennas to prevent potential interference.
- Be sure to mount the antenna near enough to the VSAT-Hub to allow you to connect the 50 ft (15 m) antenna cable (*supplied in kit*) between them, while still maintaining sufficient slack in the cable.

Note: If you need to use a longer cable, refer to [“Prepare the Antenna Cable” on page 9](#).

Mounting Structure Requirements

Make sure the mounting surface is flat, level (within $\pm 2^\circ$), and wide enough to accommodate the antenna's base. Also make sure that the structure is strong enough to withstand the weight of the antenna (23.4 lbs, 10.6 kg), as well as other cumulative forces related to expected operating conditions, such as ice, snow, wash down, and maximum expected values of pitch, roll, and wind pressure (including gusts).

Vibration of the mounting surface should measure less than 0.51 gRMS total, and also less than 0.11 gRMS at the following resonant frequencies and axes:

- 23.0 Hz and 43.0 Hz in Horizontal Forward X-Direction
- 26.0 Hz and 66.0 Hz in Horizontal Side Y-Direction
- 50.0 Hz and 76.0 Hz in Vertical Z-Direction

Note: Ship's crew should consult with the shipyard to ensure that the antenna mounting surface vibration never exceeds the above stated conditions at any time during its life.

Figure 2: Antenna Dimensions

Front View

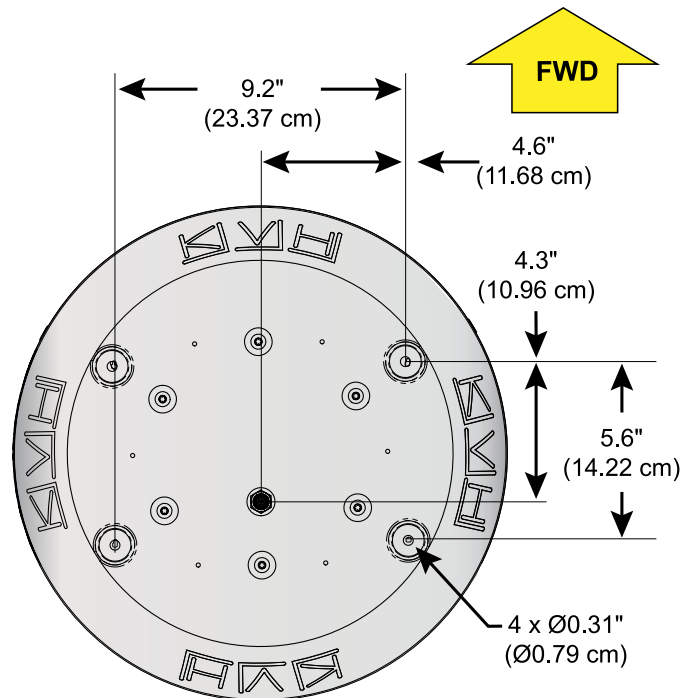
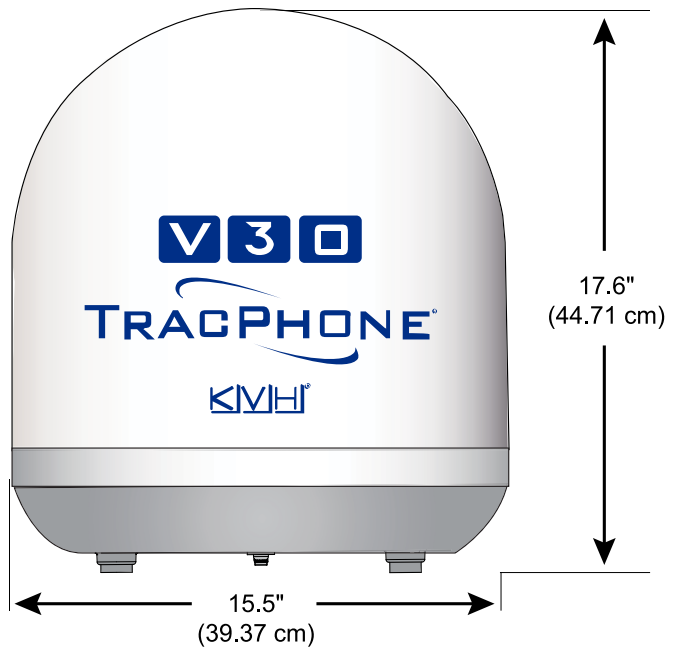

Bottom View

Pedestal Structure Requirements

If a pedestal is going to be used, it must meet the following minimum requirements.

Pedestal Height (A)	3.28 ft (1 m)	6.56 ft (2 m)	9.84 ft (3 m)	13.12 ft (4 m)
Tube OD (B)	5.0" (127 mm)	5.0" (127 mm)	5.0" (127 mm)	8.0" (203.2 mm)
Tube Wall Thickness (C)	0.25" (6.35 mm)	0.25" (6.35 mm)	0.25" (6.35 mm)	0.5" (12.7 mm)
Brace Height (D)	N/A	5.25 ft (1.6 m)	7.35 ft (2.24 m)	9.12 ft (2.78 m)
Brace OD (E)	N/A	2.25" (57.15 mm)	4.5" (114.3 mm)	7.0" (177.8 mm)
Brace Thickness (F)	N/A	0.25" (6.35 mm)	0.25" (6.35 mm)	0.25" (6.35 mm)
Brace Angle (G)	N/A	25°	25°	25°

Note: If the pedestal exceeds 3.28 ft (1 m), braces must be placed at 120° intervals. Sizing is based on Structural Steel Tubing 60,000 psi (415 MPa) minimum yield. For more details, refer to the Pedestal Specs Wizard (www.kvh.com/pedestalspecs).

Note: The ship's crew is responsible for fabricating and installing the pedestal.

Figure 3: Pedestal and Brace Dimensions

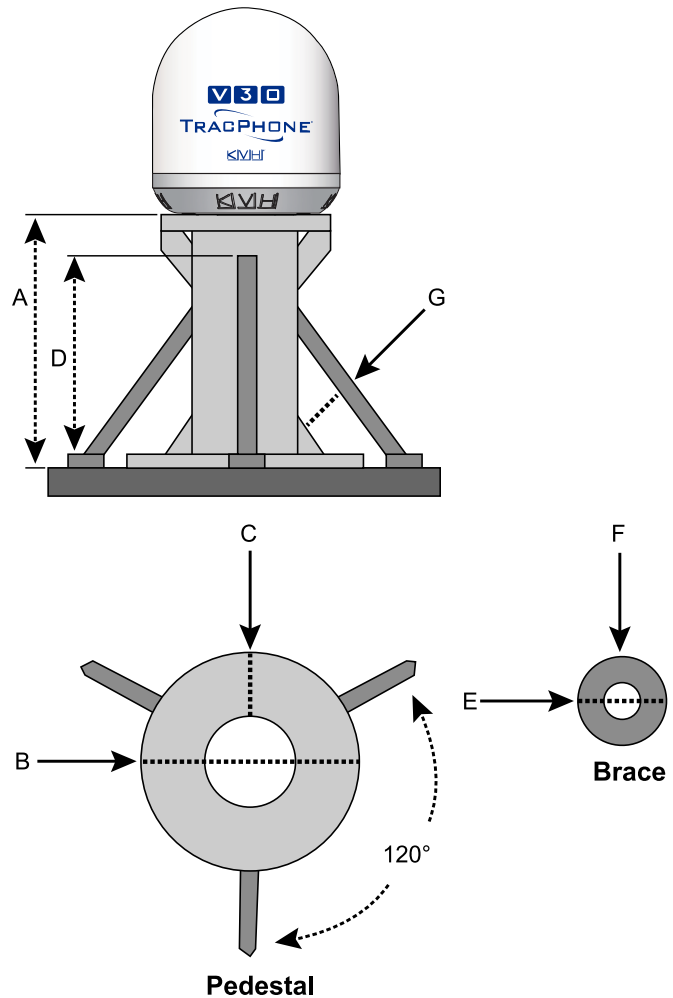

Prevent RF Radiation Exposure

Select a location that is well above any areas accessible to passengers and crew to reduce the risk of RF radiation exposure. (See [page 1](#) for an illustration of the hazard area.)

If mounting the antenna near an accessible area is unavoidable, you may configure one or two no-transmit zones to prevent transmissions in hazardous directions. (See “[Set Up No-Transmit Zones \(Optional\)](#)” on [page 23](#) for details.)

Minimize Satellite Blockage

The antenna requires a clear view of the sky to transmit and receive satellite signals. The fewer obstructions, the better the system will perform.

Figure 4: Blockage from Obstruction

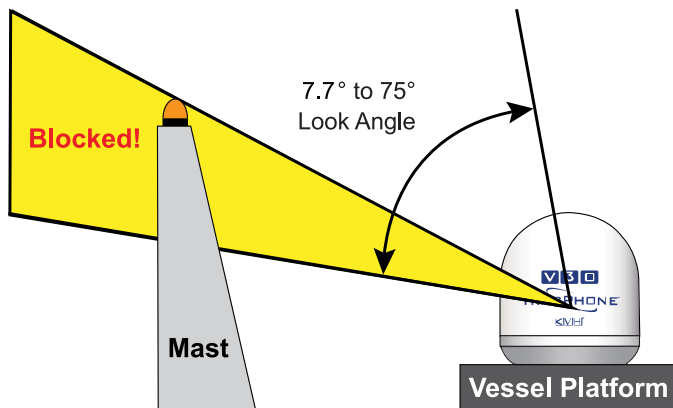

Prevent Electromagnetic Interference

To prevent the antenna from interfering with any electromagnetic-sensitive compasses or equipment, maintain a minimum distance of at least 5 ft (1.5 m) between the antenna and any compasses.

Avoid RF Interference

Although many variables determine the exact distance required between the antenna and radar/high-power radio transmitters, including transmitter beam properties and the reflective properties of nearby surfaces, consider the following general guidelines:

IMPORTANT!

RF emissions from radars and high-power radio transmitters may damage the antenna or impair its performance if it's improperly positioned within the beam path.

- Mount the antenna as far away as possible from the radar and high-power radio transmitters.
- Do not mount the antenna at the same level as the radar. Most radar transmitters emit RF energy within an elevation range of -15° to $+15^\circ$. Therefore, mount the antenna outside this elevation range and at least 10 ft (3 m) away from the transmitter.

IMPORTANT!

Never place the antenna in the beam path of the radar regardless of distance. Radar energy may damage the antenna or impair its performance.

Figure 5: Avoiding RF Interference

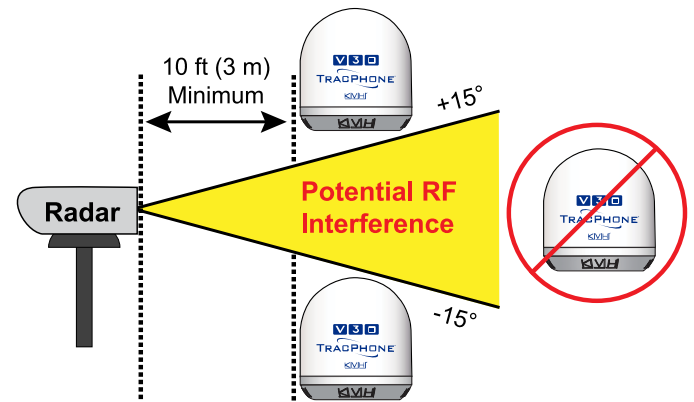

Plan the VSAT-Hub Installation

Before you install the VSAT-Hub, be sure the designated install location meets the following guidelines:

- Select a mounting location in a dry, well-ventilated area belowdecks away from any heat sources or salt spray.
- Be sure the location provides adequate Wi-Fi reception. Do not install it in an area surrounded by metal or near any electrical devices that emit RF noise.
- The VSAT-Hub can be mounted horizontally or vertically on a flat surface.
- Be sure the front panel LEDs will be visible to the user.
- Select a location that will provide adequate clearance for the VSAT-Hub dimensions.
- Leave enough room behind the rear panel (horizontal mount) or below the rear panel (vertical mount) to accommodate connecting cables and making service loops, 14" (36 cm) in diameter, within the proper bend radius. Also consider proper strain-relief of the connecting cables.
- If you plan to connect the VSAT-Hub to the vessel's onboard local area network (LAN), choose a location near an available Ethernet port.
- To use the supplied antenna cable, the VSAT-Hub must be located within 50 ft (15 m) of the antenna. However, you can order a longer cable if necessary.

Note: A template showing the exact locations of the VSAT-Hub mounting holes and the dimensions between them is provided in the Welcome Kit. Installation details are provided in ["Mount the VSAT-Hub"](#) on page 13.

Figure 6: VSAT-Hub Dimensions

Horizontal Orientation

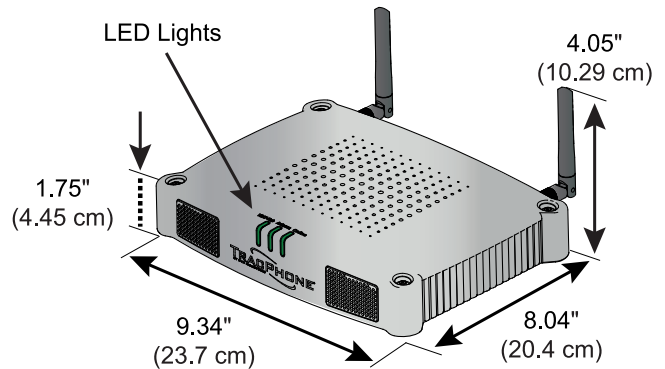

Vertical Orientation

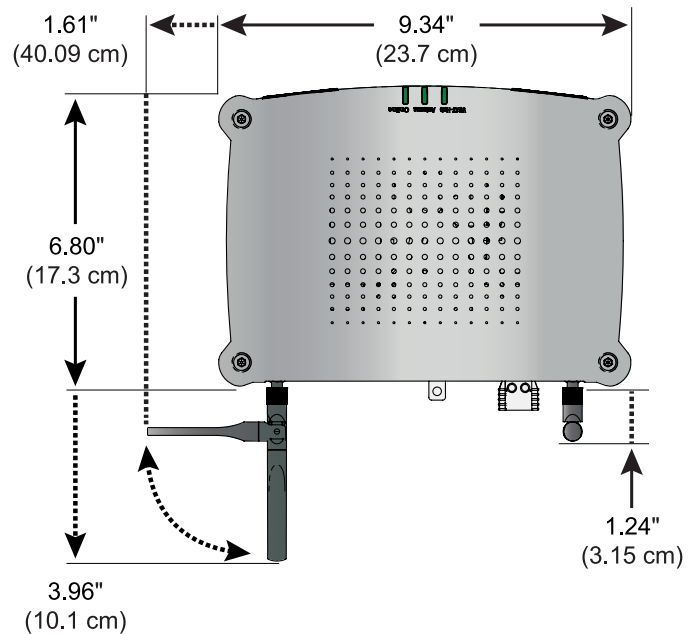

Prepare the Antenna Site

Once you have identified a suitable antenna mounting site, according to the guidelines provided in “[Plan the Antenna Installation](#)” on page 4, follow these steps to prepare the site for installation.

1. Unfold the antenna mounting template (supplied in the Customer Welcome Kit) and place it onto the mounting surface. Make sure the “FWD” (forward) arrow points toward the bow and is parallel to the vessel’s centerline.

Note: You don’t need to mount the antenna exactly on the vessel’s centerline, but the antenna’s forward arrow must be parallel to it.

Figure 7: Mounting Bolt Hole Pattern Examples

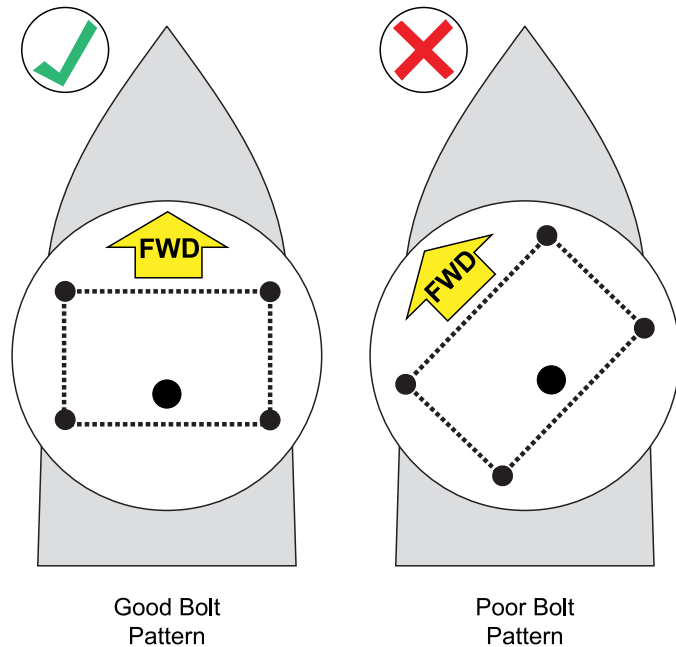

2. Using a light hammer and center punch, mark the locations for the four mounting holes and cable access hole on the mounting surface in the locations indicated on the template.
3. Drill a 5/16" (8 mm) hole at the four mounting hole locations you marked in step 2. Later, you will insert four 1/4"-20 bolts through these holes to secure the antenna to the mounting surface.
4. Cut out the 1.5" (38 mm) cable access hole in the location you marked in step 2. Smooth the edges of the hole to protect the antenna cable. (You may also apply anti-chafe material around the antenna cable to prevent abrasion.) Later, you will route the antenna cable through this hole and into the vessel.
5. Clean and dry the antenna mounting surface.

6. Peel off the paper backing from the supplied foam seal to expose the adhesive. Then press the foam seal down firmly onto the mounting surface, ensuring the hole in the foam seal aligns with the cable access hole in the mounting surface, as shown in Figure 8.

Note: Apply the foam seal to the vessel mounting surface, not to the antenna’s baseplate. You will have difficulty connecting the antenna cable to the antenna if the foam seal is attached to the baseplate.

Figure 8: Antenna Mounting Holes Layout

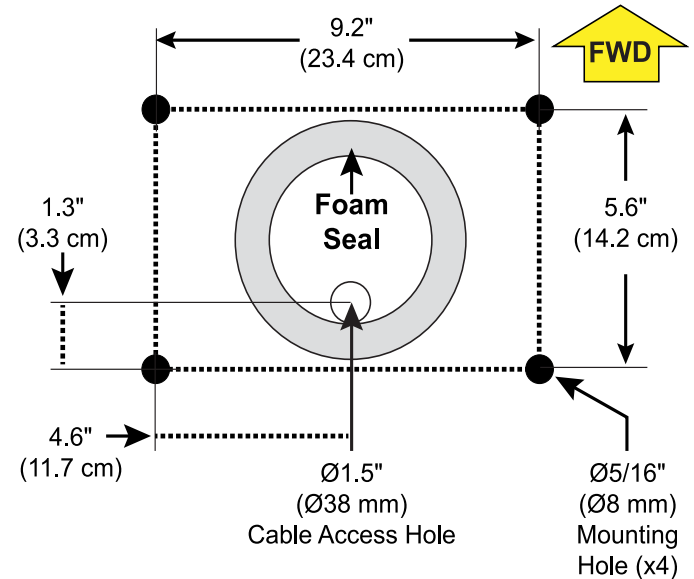

Prepare the Antenna Cable

You need to connect a single coax cable from the antenna to the belowdecks VSAT-Hub. KVH recommends using the supplied 50 ft (15 m) RG-58 cable. However, you may purchase a different cable for a longer run (see Figure 9 to determine type of cable and connector required), or you may reuse an existing cable from a previously installed antenna unit if it meets KVH requirements (refer to [“Wiring the Antenna Using a Preinstalled Cable” on page 31](#)).

IMPORTANT!

The integrity and reliability of the antenna cable is critically important. Make certain that the cable is properly terminated, sealed against seawater and corrosion, strain-relieved, protected from abrasion, and free of stress.

The cable run must meet the following requirements:

- A low-quality, poorly terminated, or improperly installed cable is the most common cause of system problems. If the cable is modified for any reason, it must be terminated again with new connectors, using the proper tools, exactly to the manufacturer’s specifications. See [“Terminating RG-58 Cable” on page 28](#) for instructions for the supplied cable. **Only KVH-authorized marine technicians should modify the antenna cable, if necessary.**
- A new antenna cable must be rated for 50Ω, not 75Ω.
- Use of any cable not specified in Figure 9 or pre-approved by KVH (refer to [“Wiring the Antenna Using a Preinstalled Cable” on page 31](#)) will void the warranty.
- Make sure the center conductor pin at each end of the finished cable is free of burrs, as well as the correct length and diameter specified in Figure 9, to ensure proper engagement.
- Make sure there is no gap between the end of the cable jacket and the start of the connector.
- When determining cable lengths, don’t forget to account for service loops, 14" (36 cm) in diameter, at each end, and ensure you can maintain the minimum bend radius (which differs per cable) throughout the cable run.
- If you use a new LMR-400 cable (or a preinstalled RG-11, LMR-400, or LMR-600 cable), you need to connect a pigtail cable between it and the VSAT-Hub. You may also use a pigtail cable at the antenna end to maintain proper bend radius. These pigtail cables are available from KVH. See [“Connecting Pigtail Cables to the Antenna Cable” on page 32](#).

Figure 9: New Cable Run Options

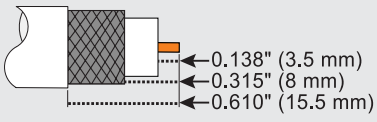
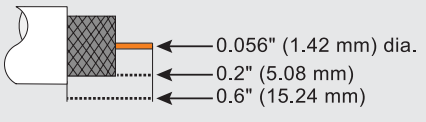
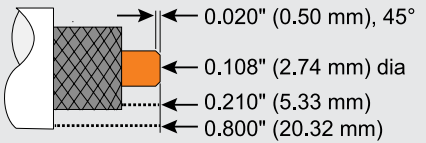
RG-58 (50Ω)	
Max. length	150 ft (45 m)
KVH part nos.	50 ft (15 m): 32-1439-0050 100 ft (30 m): 32-1439-0100 150 ft (45 m): 32-1439-0150
Connector	PE4156
Tools	Amphenol 47-10070 Crimp Tool, Steren 204-202 or Hanlong HT-312B Strip Tool (KVH part no. 72-0982)
Strip lengths	
LMR-240 (50Ω)	
Max. length	300 ft (100 m)
KVH part nos.	200 ft (60 m): 32-1453-0200 300 ft (90 m): 32-1453-0300
Connector	EZ-240-TM-X
Tools	Times Microwave CT-240 Crimp Tool, CST-240 Strip Tool, DBT-U Debur Tool (KVH part no. 72-0949)
Strip lengths	
LMR-400 (50Ω)	
Max. length	400 ft (120 m)
KVH part no.	400 ft (120 m): 32-1441-0400
Connector	EZ-400-TM-X
Tools	Times Microwave CT-400 Crimp Tool, CST-400 Strip Tool, DBT-U Debur Tool (KVH part no. 72-0950)
Strip lengths	

Note: Cables purchased from KVH include the proper connectors.

Wire the Antenna

Follow these steps to connect the antenna cable to the antenna's baseplate connector.

Route the Cable Belowdecks

1. Route the opposite end of the antenna cable belowdecks through the 1.5" (38 mm) cable access hole. Leave an adequate service loop, 14" (36 cm) in diameter, at the antenna location for serviceability.
2. Route the cable to the VSAT-Hub location. Always maintain the minimum bend radius in the cable. Later, you will connect the cable to the VSAT-Hub.

Figure 10: Minimum Bend Radius

Cable Type	Min. Bend Radius
RG-58	2" (5.1 cm)
LMR-240	2.5" (6.4 cm)
LMR-400	4.5" (11.5 cm)

Connect the Cable to the Antenna

1. Clean and dry the antenna cable's connector and the connector on the bottom of the baseplate.

Figure 11: Antenna Baseplate Connector

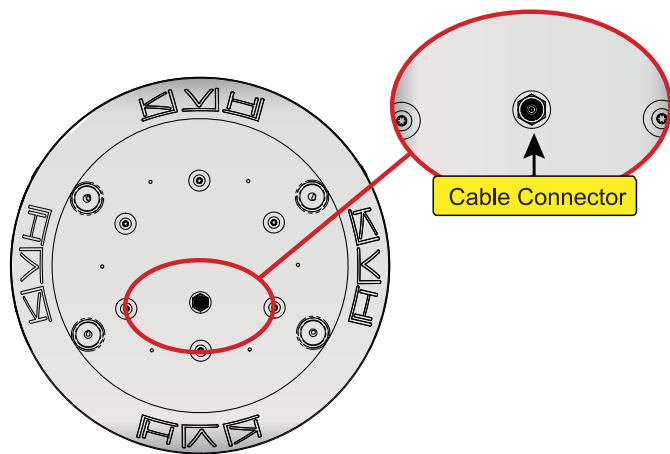

CAUTION

Be sure to observe the safe handling instructions in the Material Safety Data Sheet (MSDS) provided with the silicone grease.

2. Fill half of the inner body of the cable's male connector with the supplied silicone grease.
3. Connect and **SLOWLY** hand-tighten the cable to the antenna's connector, allowing the grease to diffuse and settle into the entire space within the connector.
4. Make sure the cable connector is hand-tightened all the way into the antenna's connector.
5. Seal the cable connection with self-vulcanizing tape or equivalent.

Figure 12: Connecting the Cable to the Antenna

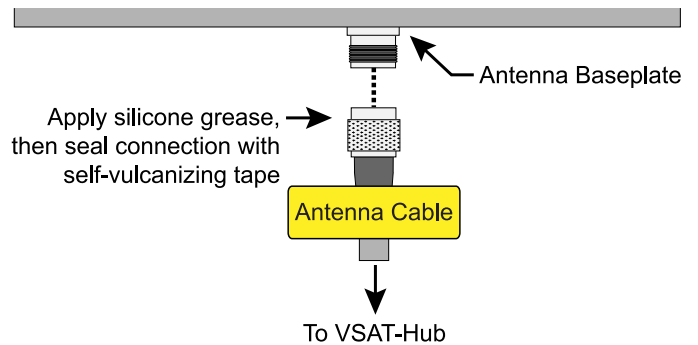

6. Secure the antenna cable near the antenna to relieve stress.
7. Weatherproof and seal the cable access hole.

Figure 13: Strain-relief (Finished Installation Example)

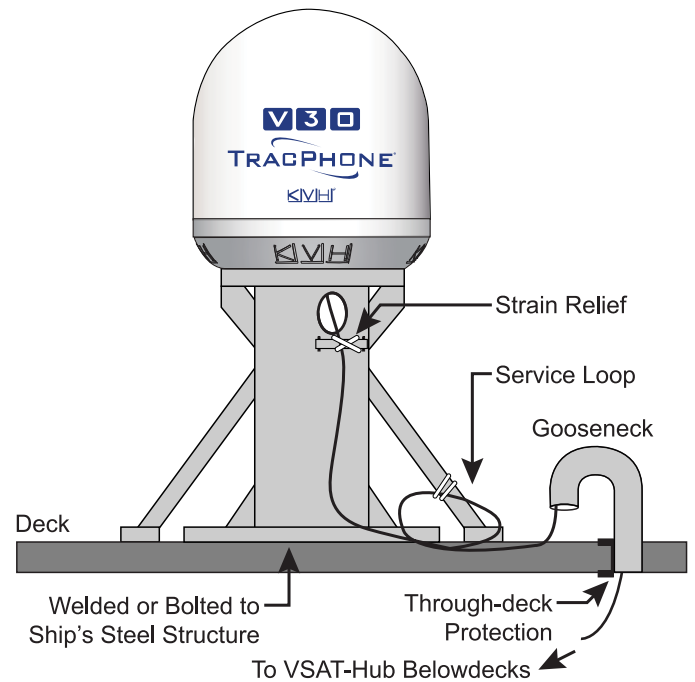

Mount the Antenna

Follow these steps to first remove the radome and foam shipping restraints, and then mount the antenna to the mounting surface.

1. Remove the three #10-32 screws securing the radome to the baseplate. Carefully lift the radome straight up until clear of the antenna assembly and set it aside in a safe place. If you keep the radome topside, secure it with a lanyard to prevent it from falling overboard.

Note: Due to the snug fit, some contact between the radome's sealing gasket and the antenna mechanism is normal during radome removal and installation.

Figure 14: Remove the Radome

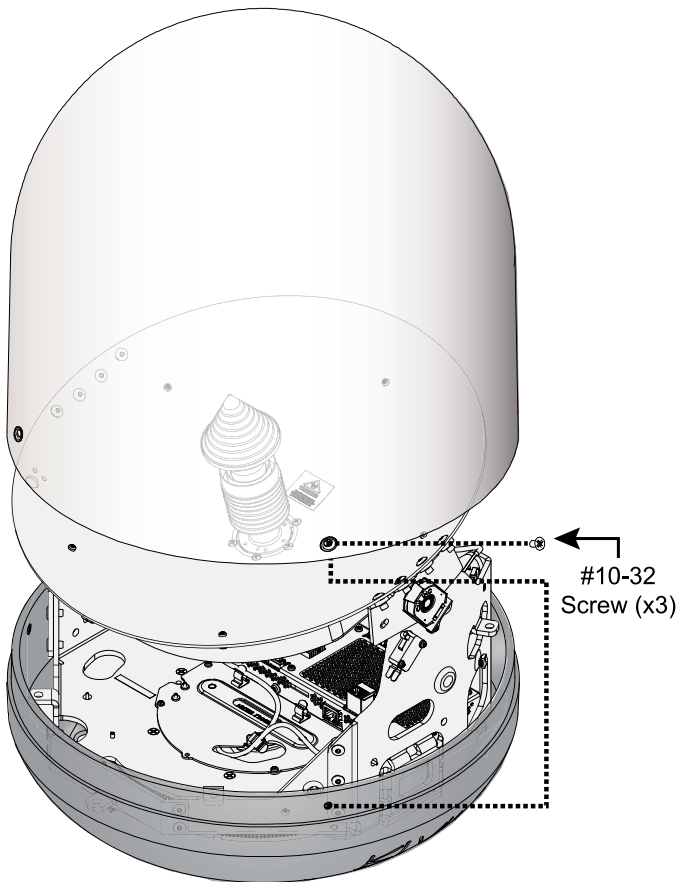

2. Remove the foam shipping restraints and save for future use.



CAUTION

Once you have removed the restraint(s), handle the antenna carefully, as its internal assembly will rotate freely. Whenever you need to tilt the antenna, be sure to guard against having the internal assembly swinging around and potentially crushing your fingers.

Figure 15: Remove the Restraints

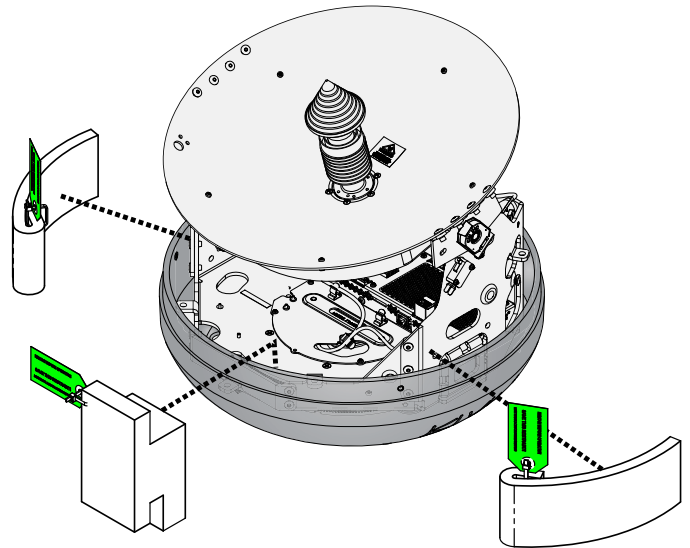

- Place the antenna baseplate over the holes drilled in the mounting surface and make sure the forward arrow inside the baseplate points toward the bow and is **parallel** to the vessel's centerline. The antenna's baseplate should rest squarely atop the foam seal.

Figure 16: Forward Arrow in Antenna Baseplate

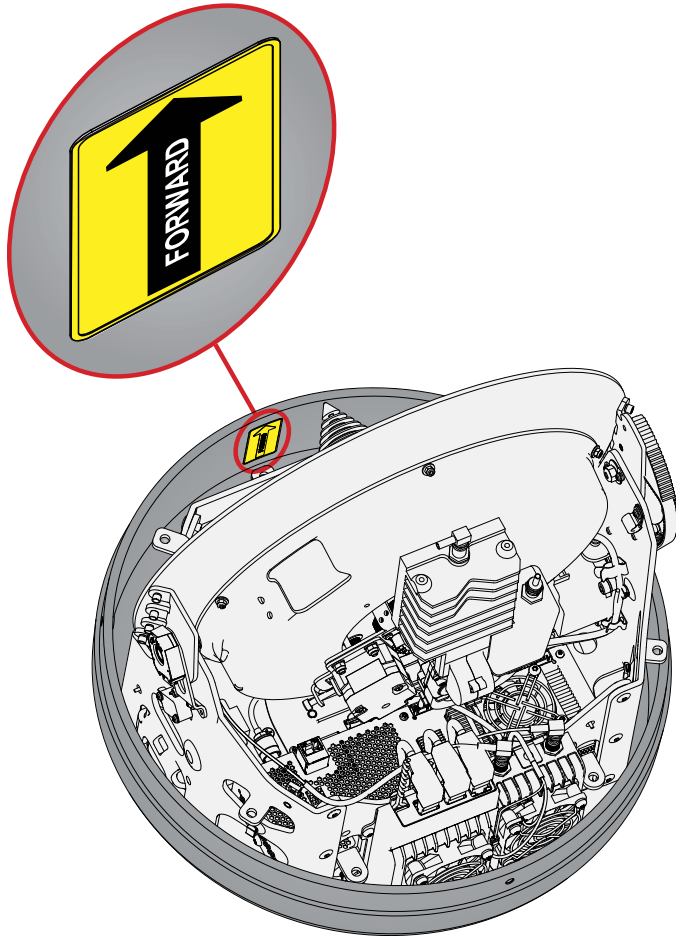

- Secure each mounting bolt to the mounting surface using a 1" diameter flat washer and a 1/4"-20 lock nut from below.
- Rotate the antenna assembly slowly by hand to reveal the other two mounting holes then repeat steps 5-6 at these two holes.
- Tighten all four bolts until the four rubber feet on the baseplate are bottomed against the mounting surface and the foam seal is fully compressed. KVH recommends that you tighten the nuts to between 25 and 30 ft-lbs (34 and 41 N-m) of torque.

Figure 17: Mounting the Antenna (Side View)

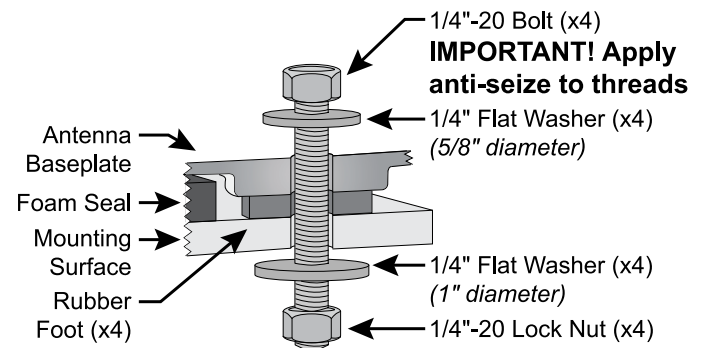

- Reinstall the radome onto the antenna. Secure in place with the three #10-32 screws you removed earlier (see [Figure 14 on page 11](#)).
- Install a protective plastic cap (*supplied in kit*) over each radome screw.

**CAUTION**

Be sure to observe the safe handling instructions in the Material Safety Data Sheet (MSDS) provided with the anti-seize lubricant.

- Apply a thin layer of the supplied anti-seize lubricant to the threads of the four 1/4"-20 bolts to prevent galling.
- At each of the two baseplate mounting holes that you can see without rotating the antenna assembly, place a 5/8" diameter flat washer on a 1/4"-20 bolt and insert the bolt into the hole from above.

IMPORTANT!

Use caution if you're using power tools. High installation speeds can damage the threads.

Mount the VSAT-Hub

Follow these steps to install the VSAT-Hub inside the vessel.

1. Before you begin, note the VSAT-Hub's serial number provided on a label on the bottom of the unit. You might need this number later, as it is the default password for the built-in Wi-Fi.
2. Tape the mounting template in the location selected for the VSAT-Hub. Punch holes at each of the two keyhole locations and at the mounting tab location.

Figure 18: VSAT-Hub Mounting Template

Mounting Template

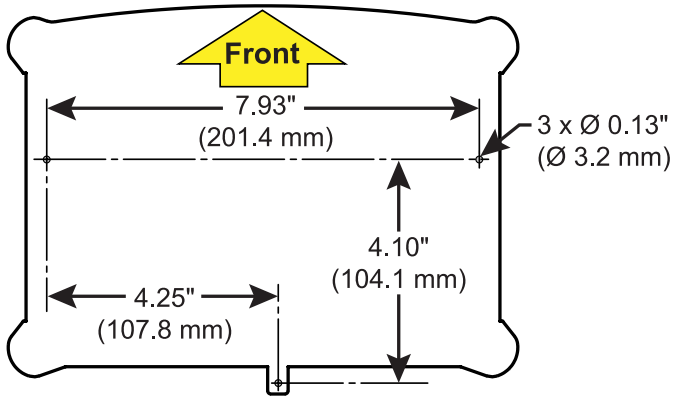

Bottom View of VSAT-Hub

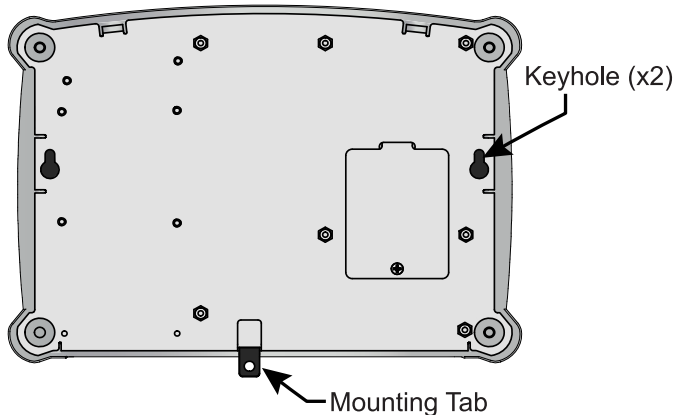

3. Remove the template.
4. Drill a 1/8" (3 mm) hole at the three hole locations you marked in step 2.
5. Install a #8 Phillips thread-forming screw partway into one of the keyhole holes leaving a small gap for hooking the VSAT-Hub onto it. Use the thickness (2.5 mm) of the M10 washer (*supplied in kit*) as a gauge for the size gap to leave.
6. Repeat step 5 for the other keyhole.

7. Peel off the backing on the adhesive-backed washer (*supplied in kit*) and place it over the mounting tab hole.
8. Align the wide part of the VSAT-Hub's keyholes, as shown in Figure 18, over the screws, then slide downwards to secure the screws into the narrow part of the keyholes.
9. Press the rear mounting tab of the VSAT-Hub onto the adhesive washer and install the third #8 Phillips thread-forming screw in the mounting tab hole.

IMPORTANT!

Make sure the VSAT-Hub is securely mounted. Any movement of the VSAT-Hub may put a strain on the antenna cable's connection.

Wire the VSAT-Hub

Follow these steps to wire the VSAT-Hub (see [page 34](#) for a complete wiring diagram).

IMPORTANT!

If you are using an RG-11, LMR-400, or LMR-600 cable, do not connect it directly to the VSAT-Hub. Connect a pigtail cable between it and the VSAT-Hub. See [“Connecting Pigtail Cables to the Antenna Cable”](#) on [page 32](#).

1. Clean and dry the VSAT-Hub’s “Antenna” connector.
2. Fill half of the inner body of the antenna cable’s male connector with the supplied silicone grease.
3. Connect and **SLOWLY** hand-tighten the cable to the VSAT-Hub connector, allowing the grease to diffuse and settle into the entire space within the connector. Do not use a tool or overtighten.

IMPORTANT!

Do not connect anything other than the antenna cable to the VSAT-Hub’s “Antenna” connector. The VSAT-Hub supplies voltage that will damage other devices.

4. Secure the antenna cable near the VSAT-Hub to relieve stress. Also make sure the cable will not get bent or twisted near the VSAT-Hub’s connection, which can put additional stress on the connector.

Figure 19: Antenna Wiring

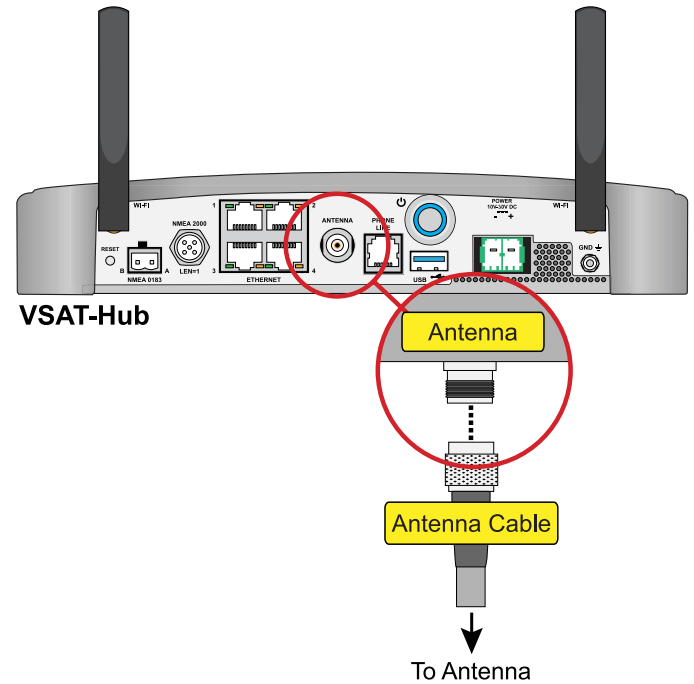

Connect an NMEA Talker

The antenna **requires** a vessel heading input from a customer-supplied NMEA 0183 or NMEA 2000 talker. Optionally, you can also provide a vessel position input to serve as a backup to the antenna's built-in GPS.

NMEA 0183

1. Connect the NMEA 0183 talker to the 2-position terminal strip connector (*supplied in kit*), as shown in Figure 22. Then plug the connector into the rear panel of the VSAT-Hub.
2. Configure the NMEA device to transmit one or more of the supported NMEA 0183 messages at 4800 baud.
3. Make sure the data message(s) includes the checksum, identifiable by a *xx field at the end of the data sentence (e.g., \$HEHDT,123.4, T*1F). See [“Verifying the NMEA 0183 Message” on page 33](#) for details. Do not exceed a 10 Hz input rate.

Note: To supply both the required heading and the optional position to the VSAT-Hub, you can either connect an NMEA 0183 talker that transmits both messages, or connect two devices using an NMEA data multiplexer, such as Actisense® model NDC-4.

Figure 20: Supported NMEA 0183 Messages

NMEA 0183 \$-XXX	Description
Heading Messages	
HDG	Heading, Deviation & Variation
HDM	Heading, Magnetic
HDT	Heading, True
OSD	Own Ship Data
THS	True Heading & Status
VHW	Water Speed and Heading
Position Message (Optional)	
RMC	Position (Optional)

NMEA 2000

1. Connect the VSAT-Hub to the vessel's NMEA 2000 CAN network backbone via a “T” connector. Be sure to use a standard drop cable: 5-wire (4 conductors + shield) twisted pair with micro-C connectors.
2. Configure the NMEA device to transmit one or more of the supported NMEA 2000 messages.

Figure 21: Supported NMEA 2000 Messages

PGN	Description
Heading Messages	
127250	Vessel Heading
Position Message (Optional)	
129029	GNSS Position Data (Optional)

Figure 22: NMEA Talker Wiring

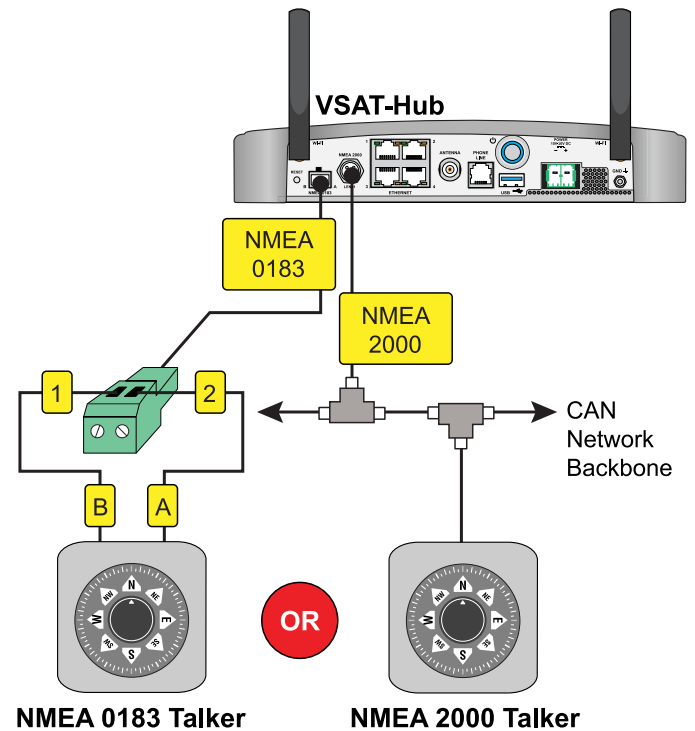

Connect Power

Follow the steps in this section to properly ground the TracPhone V30 system and connect power.

Grounding Requirements

Proper grounding of the TracPhone system to ship's ground is mandatory for electromagnetic compatibility (EMC) and safety regulatory compliance. It protects the equipment from electrostatic discharges (ESD) and prevents interference with other electronic equipment. Follow these steps to ground the system.

1. Connect the hoop of the grounding wire (*supplied in kit*) to the "GND" screw on the rear panel of the VSAT-Hub.
2. Connect the other end of the grounding wire to ship's common ground.



WARNING

Failure to ground the TracPhone system properly to the vessel's ground will cause an unsafe floating ground condition, risking damage to the antenna and electric shock, potentially resulting in DEATH. In a floating ground condition, the difference between the equipment's chassis ground and the vessel's ground can measure well over 100 volts, when it normally should not exceed 2 volts. Therefore, always measure the difference in potential between chassis ground and the vessel's ground to make certain that there is no dangerous floating ground condition.

Figure 23: Grounding the VSAT-Hub

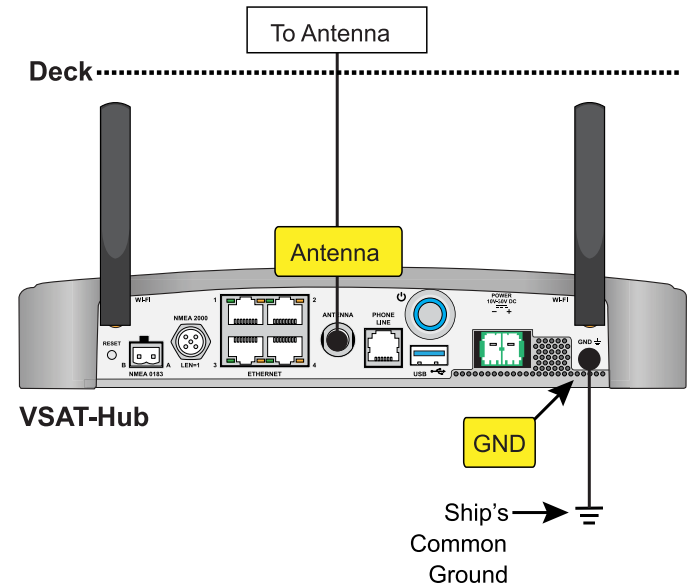

Connect Power to the VSAT-Hub

Follow these steps to connect power to the TracPhone V30 system.

IMPORTANT!

All power connections must be hard wired.

1. Before you begin, disconnect vessel power and be sure the vessel is properly grounded in accordance with marine standards.
2. Connect the supplied power cable wires to the supplied 2-position terminal strip connector:
 - Connect the black wire from “Vin-” on the terminal strip connector to DC Return.
 - Connect the red wire from “Vin+” on the terminal strip connector to the vessel’s 12 or 24 VDC (160 W max.) power source.

Note: To connect to AC vessel power, an optional 24 VDC AC-DC power supply (5A, 160 W) is available from KVH (part no. 72-0953). Consider installing an uninterruptible power supply (UPS) between the AC-DC power supply and vessel power to avoid service interruptions during power outages and transitions to/from shore power.

3. Insert a fuse (supplied in kit) into the in-line fuse holder. If vessel power supplies 12 volts, use the blue 15A fuse. If vessel power supplies 24 volts, use the brown 5A fuse.
4. Connect the terminal strip connector to the VSAT-Hub’s Power connector.
5. Check for proper grounding by using a multimeter to measure the AC and DC voltages between the ground stud on the rear of the VSAT-Hub and ship’s ground. The measured voltage should be less than 2 VAC and 2 VDC. **A higher voltage indicates a dangerous floating ground condition.**
6. Repeat step 5 with the VSAT-Hub powered on, looking for the same measured result.



WARNING

If you measure 2 volts or greater between the ground stud on the rear of the VSAT-Hub and ship’s ground, notify the ship’s electrician or authorized vessel representative immediately. This is a dangerous condition. Do not touch the VSAT-Hub rear panel or connect anything to it until the problem is fixed.

Figure 24: Power Wiring

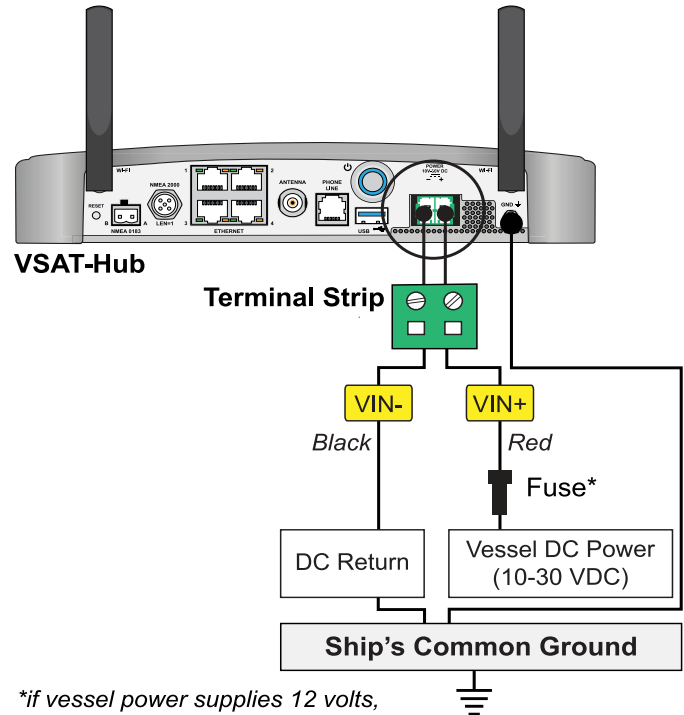

*if vessel power supplies 12 volts, use blue 15A fuse; if vessel power supplies 24 volts, use brown 5A fuse

Turn On the System

Follow these steps to turn on the system.

1. Ensure the antenna has a clear, unobstructed view of the sky.
2. Apply vessel power to the TracPhone V30 system.
3. Press the power button on the back of the VSAT-Hub. The button's light should illuminate blue.

Figure 25: Power Button

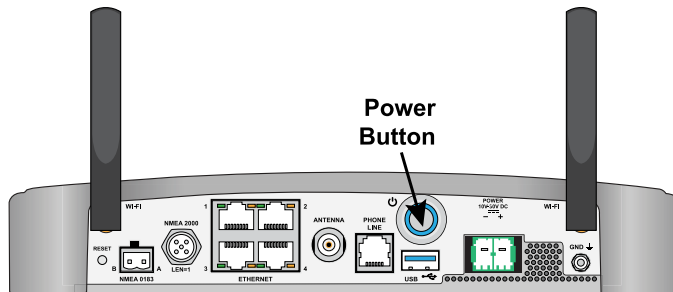

VSAT-Hub

IMPORTANT!

During startup, the VSAT-Hub checks the software version installed in the antenna and updates it if necessary to match its currently installed version. Do not turn off the system for at least 15 minutes to allow any updates to complete.

4. Within one minute, the “VSAT-Hub” light will glow green. Within a few minutes, the “Antenna” light will be flashing green, indicating the antenna is searching for the satellite.

Figure 26: Status Lights

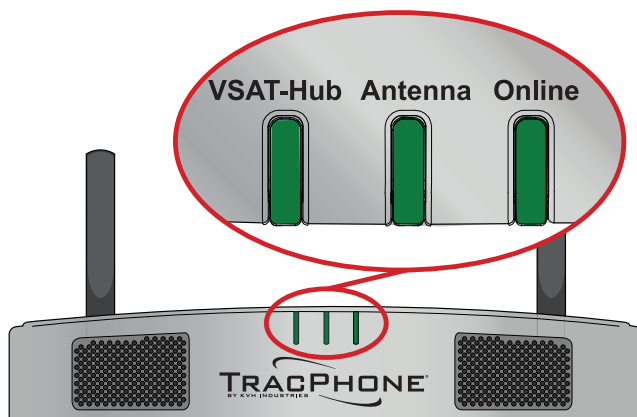

VSAT-Hub

Set Up the System

Follow the steps on the next few pages to access the setup wizard and configure system for use.

Access the Setup Wizard

Follow the steps for either option below to access the VSAT-Hub's setup wizard.

Option 1: Using the Wireless Connection

1. Select the **KVHVSAT-*<last 3 digits of VSAT-Hub serial no.>*** network from your mobile device's Wi-Fi settings to connect to the VSAT-Hub.
2. Enter the default password: ***<full 9-digit VSAT-Hub serial no.>***.
3. Start the web browser and enter **<https://kvhonboard.com>**.

Note: If the setup wizard is not displayed, try entering <http://192.168.5.1>, which is the default IP address of the VSAT-Hub.

Figure 27: Wi-Fi Connection

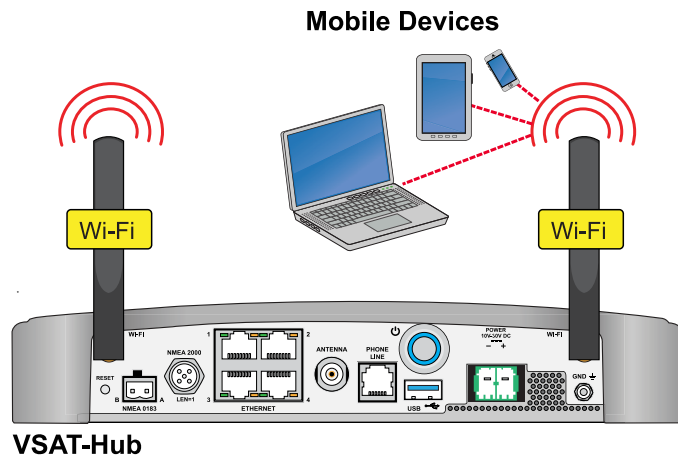

Option 2: Using the Ethernet Connection

1. Connect a laptop PC configured for DHCP directly to any "Ethernet" port on the VSAT-Hub.
2. Start the web browser and enter **<https://kvhonboard.com>**.

Note: If the setup wizard is not displayed, try entering <http://192.168.5.1>, which is the default IP address of the VSAT-Hub.

Figure 28: Wired Ethernet Connection

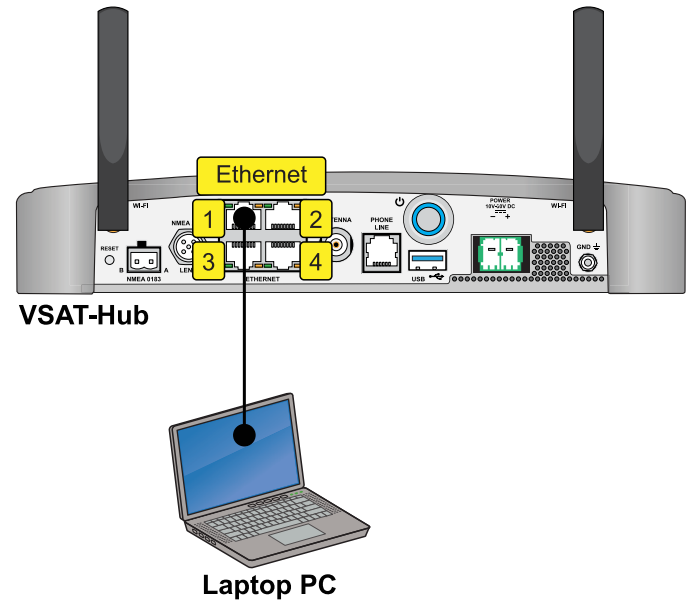

Run the Setup Wizard

The Setup Wizard appears upon initial startup to step you through system configuration. Through the setup wizard, you will:

- Enter an administrator account password
- Enter the vessel name
- Enter a phone line name
- Enter a guest account password (optional)
- Configure LAN settings (optional)
- Configure built-in Wi-Fi settings

Follow the steps in the following sections to set up the system.

Figure 29: Wizard Welcome Screen



Note: After setup is complete, you must log into the web interface as an administrator to make changes to the system settings.

Assign an Administrator Password

At the first page of the wizard, you must set the following:

- **PASSWORD:** Enter and then re-enter an administrator password of the customer's choice
- **VESSEL NAME:** Enter the vessel name
- **PHONE LINE NAME:** Enter a phone line name

Note: The case-sensitive password must be between 8 and 64 characters in length, with at least one letter, one number, and a special character.

Figure 30: Assigning the Administrator Password

When you are done, select **Next**.

Assign a Guest Account Password

At the second page of the wizard, you must set the following:

- **PASSWORD:** Enter and then re-enter a guest account password of the customer's choice

Note: *The case-sensitive password must be between 8 and 64 characters in length, with at least one letter, one number, and a special character.*

Figure 31: Assigning the Guest Password

When you are done, select **Next**.

Configure LAN Settings (Optional)

At the third page of the wizard, if desired, you can make changes to the following LAN settings:

IMPORTANT!

The default LAN settings work well for most installations. Do not change these settings unless absolutely necessary to avoid conflicts with an existing onboard network.

- **IP ADDRESS:** Change the default IP address
- **SUBNET MASK:** Change the default subnet mask
- **DHCP MODE:** Set to "ON" or "OFF" (If DHCP is on, select a **DHCP START** and **DHCP END** range)

Note: *By default, the LAN has a gateway of 192.168.5.1 and assigns IP addresses in the 192.168.5.50-150 range.*

Figure 32: Configuring LAN Settings

Configure the Built-In Wi-Fi Settings

With Wi-Fi enabled, vessel devices can connect to the VSAT-Hub via its built-in wireless access point (WAP) and receive IP addresses from the VSAT-Hub via DHCP. At the fourth page of the wizard, you can make changes to the following Wi-Fi settings:

IMPORTANT!

Establishing a wireless connection onboard a steel vessel might require a special external WAP and advanced networking expertise.

- **BUILT-IN WI-FI:** Set to “ON” or “OFF”

IMPORTANT!

For the customer’s protection, an open Wi-Fi connection without security protocols is not permitted. Setting Built-in Wi-Fi to “On” will simultaneously activate WPA-PSK security and require creating a Wi-Fi password.

- **SSID (WI-FI NETWORK NAME):** Enter a unique name for the Wi-Fi network
- **BAND:** Select either 2.4 GHz or 5 GHz
- **CHANNEL:** Select either Auto or 1-11 channels
- **PASSWORD:** Change the password (at least 8 characters)

Figure 33: Configuring the Built-in Wi-Fi Settings

TracPhone V30 Setup Wizard

1. Admin Account 2. Guest Account 3. LAN Settings **4. Wi-Fi Settings** Done!

Configure Built-in Wi-Fi Settings
Enable security on the belowdeck unit's built-in Wi-Fi, or turn it off.

BUILT-IN WI-FI *	<input checked="" type="checkbox"/> ON <input type="checkbox"/> OFF
SSID (WI-FI NETWORK NAME)*	ZoeBDUIO
SECURITY MODE*	WPA-PSK
BAND *	5 GHz
CHANNEL *	Auto
PASSWORD*	***** <input type="checkbox"/>

When you are done, select **Next**. At the final screen, select **Exit Wizard** to go to the login page, and enter the admin credentials to access the web interface.

Update the System Software

Follow these steps to check the currently installed software versions and install new software, if necessary.

Note: This procedure explains how to update the software using the web interface and your laptop computer. However, you can also update the software using the KVH V30 mobile app or, if the system is activated, via the antenna’s Internet connection (airtime charges may apply). Details are available in the Help.

1. At the web interface, go to the **Software Updates** page. Note the displayed software versions for antenna and belowdecks unit.

Figure 34: Software Updates Page

Software Updates
Last Update: 2021-08-19 05:48:38 UTC

Update Software from This Computer
To update the system's software using a file located on this computer, click Choose File.

Software Update Status	Software Versions
All Components Up-to-date	ANTENNA: 1.1.1-0-gb5aa491-build160-prod
LAST CHECK FOR UPDATES: 2021-08-19 05:48:38	VSAT MODEM: 2.0.1.2-3719
	MTA: 3.1.2 (Build: 5897P)
	BELOWDECK'S UNIT: 1.1.1-0-gf03d7b22-build331-prod

2. If the reported software versions are earlier than the latest version you downloaded from the KVH Partner Portal, select **CHOOSE FILE**.

Note: This single software update file applies to both the antenna and the belowdecks unit (i.e., VSAT-Hub).

3. Select the software update file you saved on your laptop.

IMPORTANT!

Once the file is uploaded, you will lose your connection to the web interface (and the built-in Wi-Fi) temporarily. If you would like to view the status of the update, you may log back into the web interface after a couple minutes, go to the Support page, and refresh your browser window to view the current state in the Software Update Status box.

4. Wait 15 minutes for the software update to complete.
5. Reconnect to the web interface and verify that the Software Updates page is now displaying the latest version.

Set Up No-Transmit Zones (Optional)

To prevent exposure to RF energy (see page 1 for an illustration of the hazard area), you can configure up to two no-transmit zones for areas where crew and/or passengers frequent. The system will disable the transmitter whenever the antenna is pointing within one of these zones.

Figure 35: Example of a No-Transmit Zone

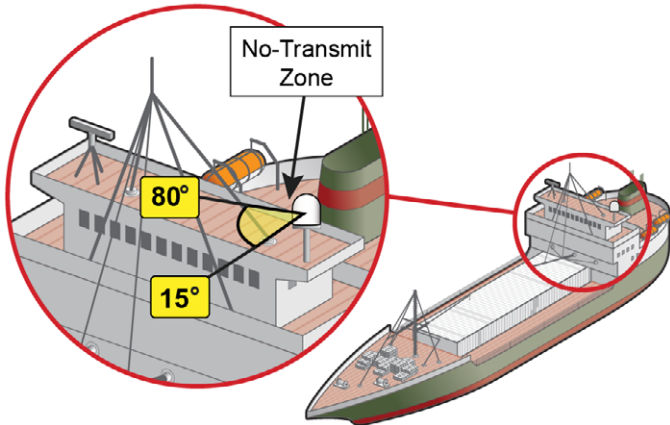

Follow these steps to set up a no-transmit zone.

1. Determine the necessary azimuth range for the no-transmit zone(s). You will need to enter, in clockwise order, beginning and ending azimuths that define the outer boundaries of the zone(s) **relative to the antenna's forward arrow**, which should be pointing toward the bow.

Figure 36: Azimuth Relative to Antenna's Forward Arrow

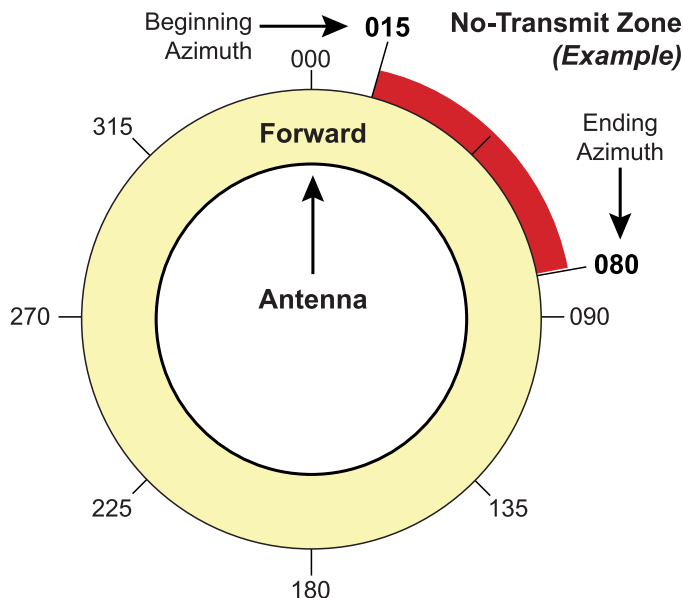

Note: Each no-transmit zone must span at least 5°. Therefore, be sure to set the beginning and ending azimuths at least 5° apart.

2. At the web interface, select the **No-Transmit Zones** page. Then select **Edit**.
3. Select **Enforce Zones**.

Figure 37: No-Transmit Zones Page of Web Interface

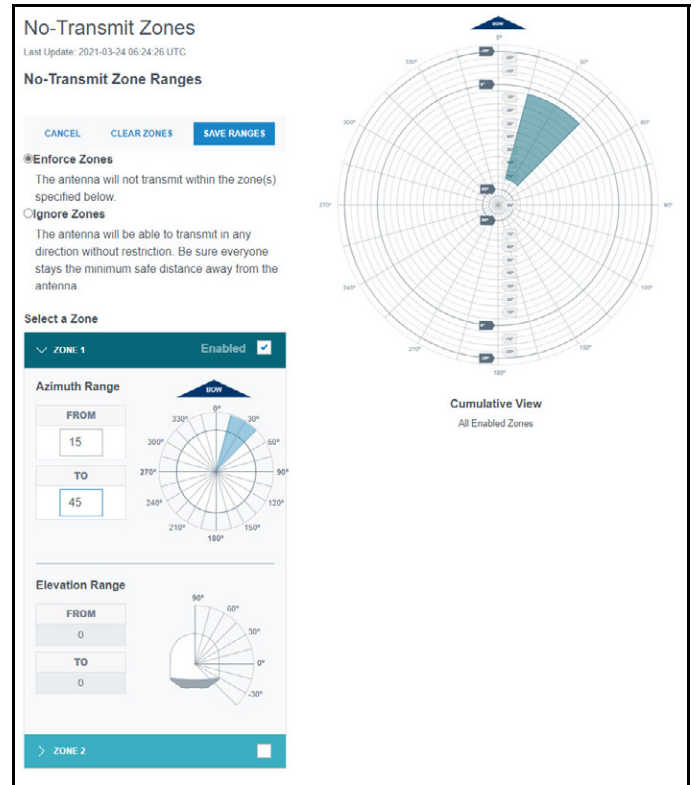

4. Enter the azimuth range for Zone 1.
5. Enter the azimuth range for Zone 2, if required.
6. Select **Save Ranges**.

Note: The elevation range is automatically set to the antenna's operating range.

Test the System

Follow these steps to test the system for proper operation.

1. Ensure the antenna has a clear, unobstructed view of the sky.
2. Verify that the antenna is tracking the service satellite and the system is online, as indicated by the Home page of the TracPhone V30 web interface.

Figure 38: Good Service Connection Indicated in Web Interface

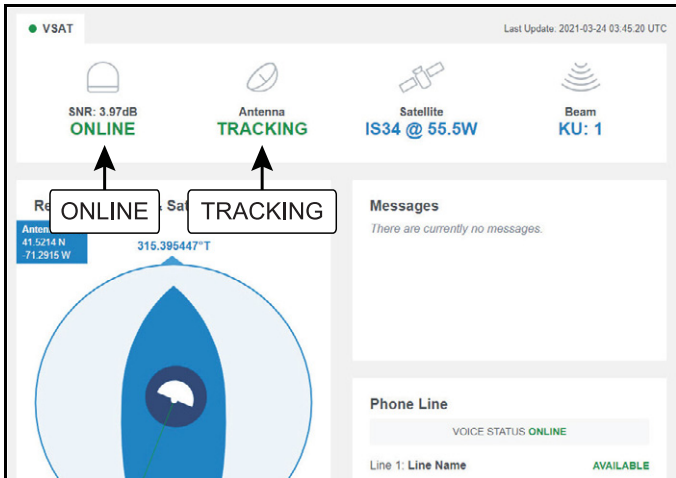

3. Make sure the vessel's heading is displayed in the Real-time Vessel & VSAT Satellite Display. If not, check the wiring to the NMEA talker.

Figure 39: Heading Displayed in Web Interface

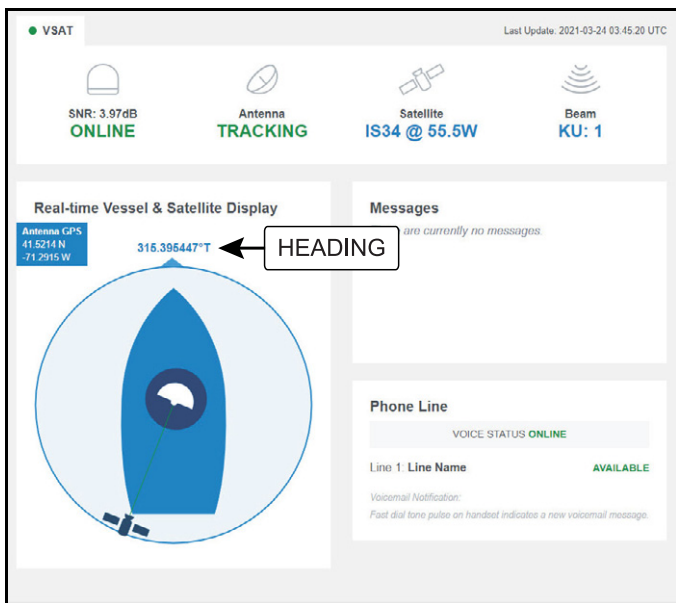

4. Enter the following address in the web browser:
http://test.minivsat.net.

5. Verify that the Welcome screen appears, indicating good communication between the TracPhone V30 system and the land-based hub.

Figure 40: Welcome Screen for Testing

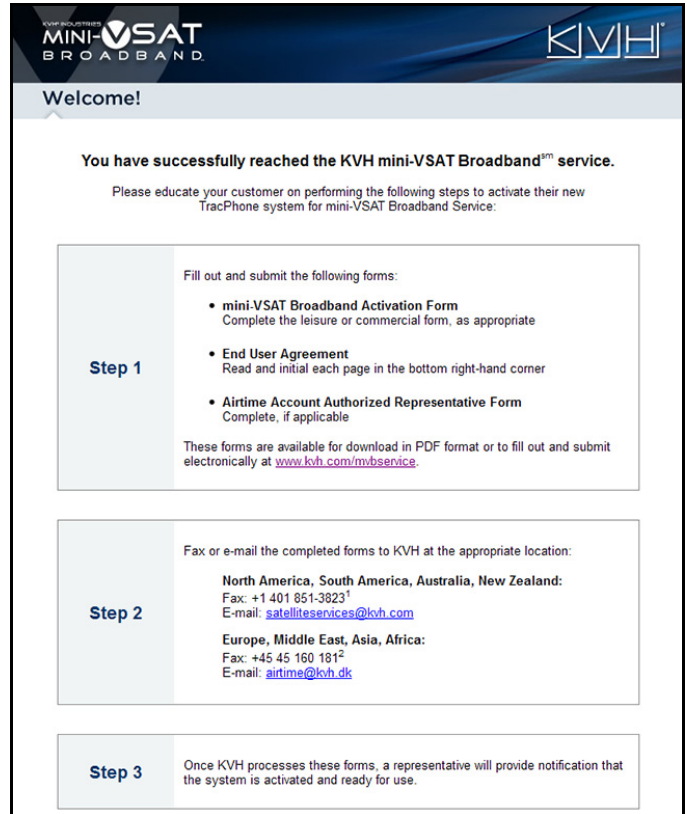

6. Turn on all other electronic equipment above deck within the proximity of the antenna. Verify that the system continues to operate without any degradation in performance.
7. Fill out the Installation Checklist (provided in the Customer Welcome Kit) and return it to KVVH. Refer to the instructions on the form.

IMPORTANT!

Submission of the Installation Checklist is required to certify the quality of the installation.

Configure the Network

The VSAT-Hub includes four Ethernet ports and a built-in wireless access point (WAP). Ethernet ports 1 through 4 and the built-in WAP provide high-speed Internet access. Follow these additional steps to set up the network.

1. Connect the computers and/or other network devices to the VSAT-Hub. You might wish to add an external WAP (or Wi-Fi router configured for bridge mode) to supplement Wi-Fi access.

Figure 41: Vessel Network Example

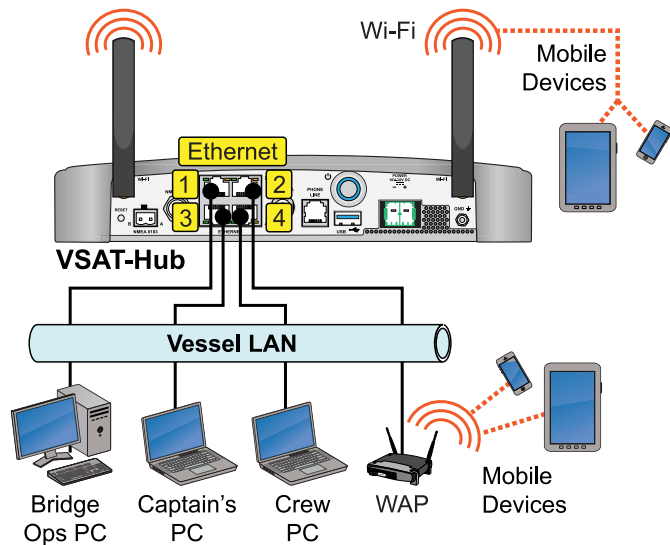

2. Devices connected to the VSAT-Hub (via Ethernet cables or Wi-Fi) will receive IP addresses from the VSAT-Hub via DHCP. The VSAT-Hub serves as a router.

Note: By default, the LAN has a gateway of 192.168.5.1 and assigns IP addresses in the 192.168.5.50-150 range. If this configuration conflicts with an existing onboard network, you may change the settings at the TracPhone V30 web interface (go to Settings > Network Settings).

Global Static IP

Global Static IP service allows you to set up a network device with an IP address that can be accessed directly from the Internet. It does not receive an IP address from the VSAT-Hub. If you require Global Static IP Service, follow these additional steps to configure the network.

IMPORTANT!

A static IP address should only be assigned to a secure device, such as a firewall router.

1. Fill out the request form at www.kvh.com/staticip. In addition, the system must be activated for mini-VSAT Broadband service, and it must remain online until KVH configures the system over the air.
2. Connect the static IP device(s) to the VSAT-Hub.
3. You will need to configure the devices' TCP/IP properties according to the instructions KVH will provide in an email upon fulfilling the static IP request.

Connect the Vessel Phone

Using the supplied RJ-11 cable, connect the analog (not digital) phone or PABX to the VSAT-Hub's "PHONE LINE" jack.

Figure 42: Connecting the Vessel Phone (Example)

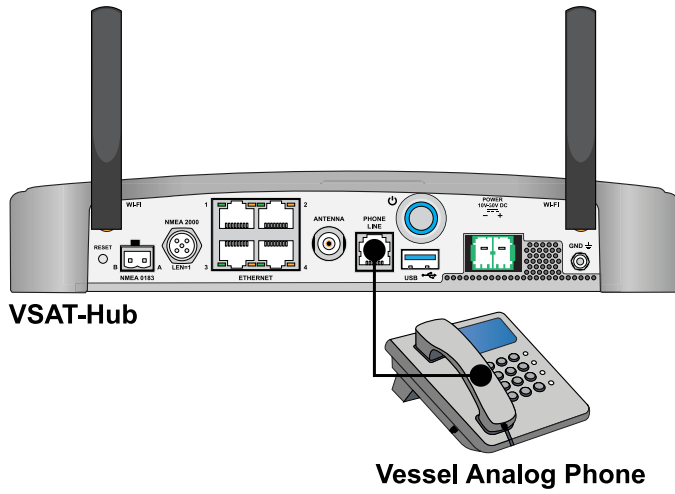

VSAT-Hub

Vessel Analog Phone

Educate the Customer

Give the Welcome Kit to the customer, make sure they know the administrator and Wi-Fi passwords, and show them how to use the system. Be sure they understand the following:

- The antenna transmits RF energy that is potentially harmful. Whenever the system is powered on, make sure everyone stays the minimum safe distance away from the antenna (see [page 1](#) for an illustration of the hazard area). If no-transmit zones were set up, make sure the customer understands where they are.
- Read the End User Agreement carefully (available at www.kvh.com/mvbcustomercenter).
- Keep the radome installed on the antenna at all times. The radome protects the antenna's moving parts from wind, rain, and debris.
- The antenna must have a clear view of the sky to communicate via satellite. Common causes of blockage include masts, trees, buildings, and bridges. Dirt buildup on the radome can also affect communications.

Figure 43: Example of Satellite Blockage

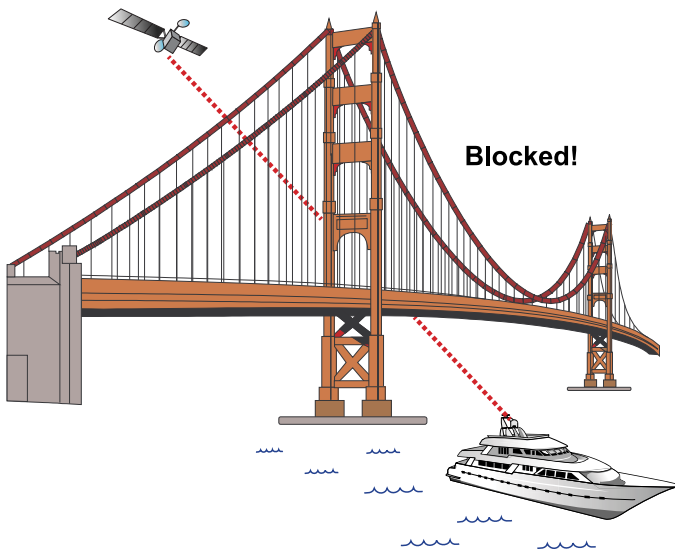

- The vessel must be located within the coverage area of the satellite (see www.kvh.com/minivsatmap).
- The system must be activated for mini-VSAT Broadband service (see www.kvh.com/mvbservice).

- Data usage and overage alerts via email and text message can be configured easily over the Internet at the KVH Manager (see www.mykvh.com).

IMPORTANT!

If you are not a KVH Airtime customer, contact your Service Provider for details on accessing KVH Manager.

- Category Controls in KVH Manager are essential to managing data usage and ensuring that data is utilized for activities that matter most.

For More Information

Refer to the Help provided on the web interface's Support page.

Figure 44: Help Button on Support Page

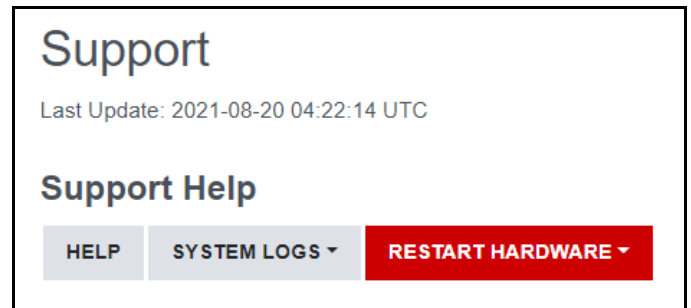

Appendix A: Terminating RG-58 Cable

These instructions explain how to terminate an RG-58 antenna cable with a PE4156 TNC connector using the tools from the RG-58 tool kit (KVH part no. 72-0982). A video of this procedure is available on YouTube, titled [Terminating an RG-58 Cable with a TNC Connector](#).

Note: For detailed instructions on terminating LMR-240 or LMR-400 cable, refer to the Times Microwave website: www.timesmicrowave.com.

1. Cut the cable evenly. Then gently round the end of the cable and make sure the center conductor is centered within the cable.

Figure 45: Cutting the Cable

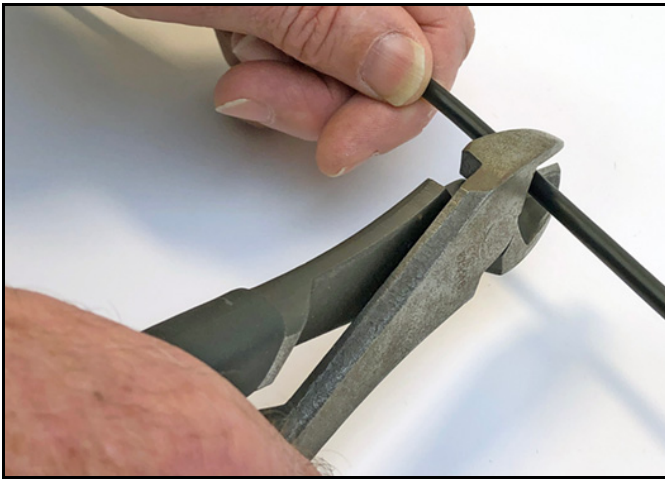

2. Push the rubber boot onto the end of the cable, narrow end first. *Applying a small amount of silicone grease to the cable jacket for lubrication will make it easier to slide the boot onto the end of the cable.*
3. Slide the metal ferrule onto the end of the cable.

Figure 46: Placing the Rubber Boot and Ferrule onto the Cable



4. Make sure the stripping tool is set up properly for RG-58 cable. Then depress the tab on the top of the tool and place the end of the cable into the cutting chamber. Be sure the end of the cable is flush with the edge of the tool that has the "58" label.

Figure 47: Inserting the Cable into the Stripping Tool

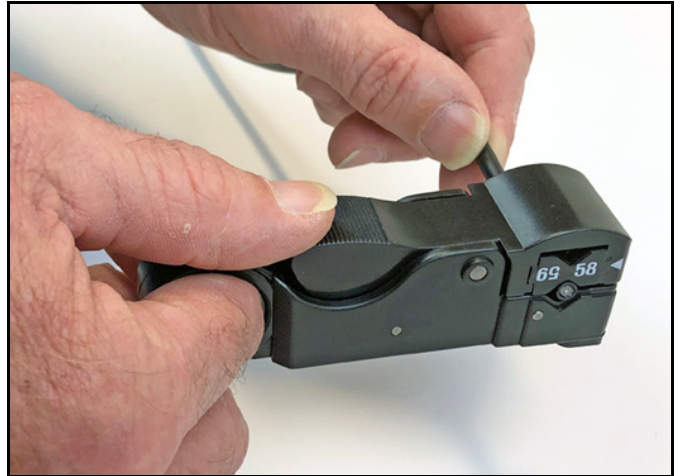

5. Once the cable is in position, release the tab. Then rotate the tool clockwise around the cable until the tool turns easily. Depress the tab and remove the cable from the tool.

Figure 48: Stripping the Cable

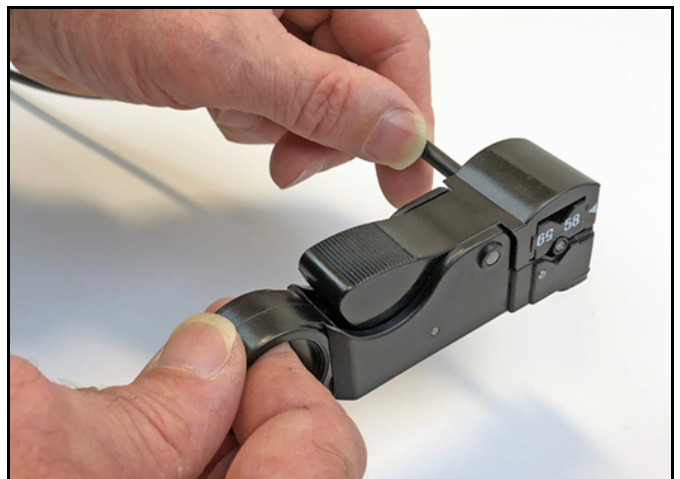

6. Remove the debris from the end of the cable to expose the braid, dielectric, and center conductor. Carefully trim back any stray strands of braid that extend into the area of the exposed dielectric.

Figure 49: Properly Stripped Cable

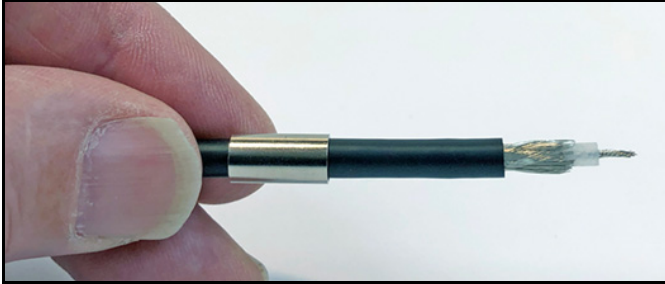

7. Place the center pin into the crimp tool in the chamber labeled “.068”. Then insert the cable’s center conductor fully into the center pin. Crimp the center pin onto the center conductor.

Figure 50: Crimping the Center Pin onto the Center Conductor

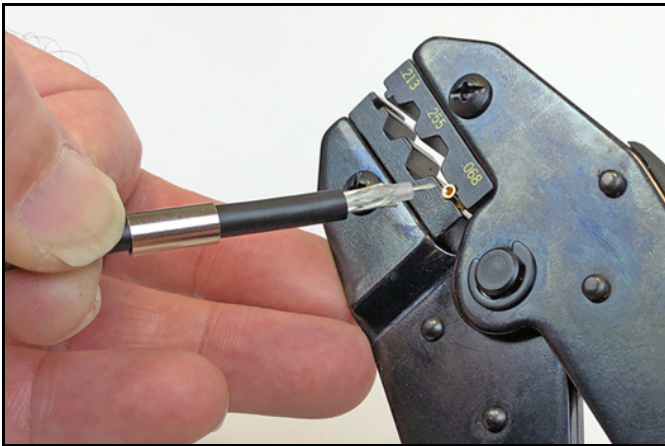
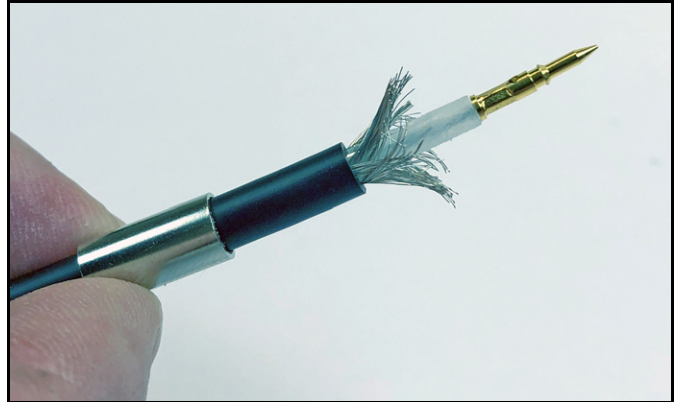

Figure 51: Center Pin Crimped in Place



8. Gently flare the braid.

Figure 52: Flared Braid



9. Insert the end of the cable into the neck of the connector until the center pin and dielectric are firmly seated inside. The connector should snap into place.

Figure 53: Pushing On the Connector

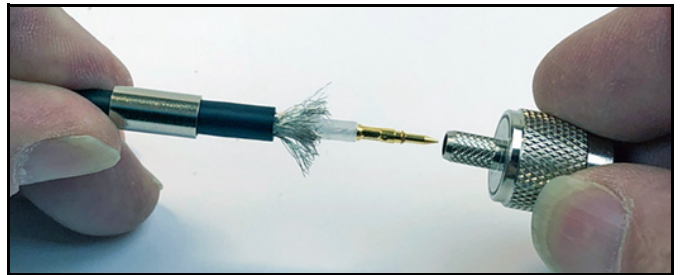
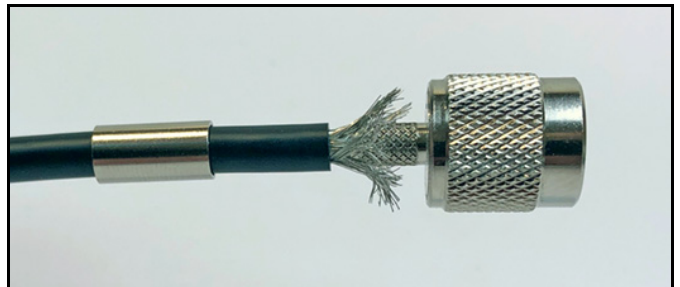
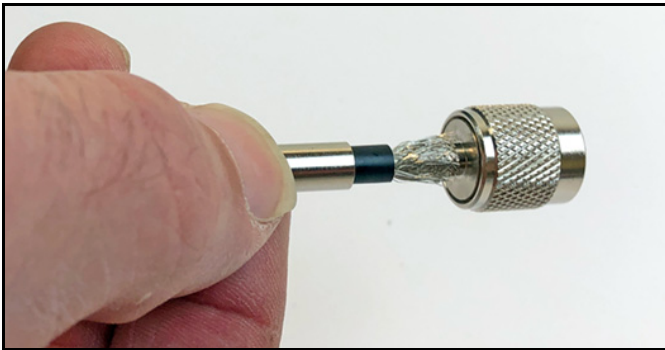

Figure 54: Connector Snapped into Place



10. Slide the ferrule up the cable and over the braid until it is flush against the connector shoulder.

Figure 55: Sliding the Ferrule over the Braid



11. Place the cable's connector into the crimp tool in the chamber labeled ".213". Be sure the tool abuts the connector shoulder so that the ferrule extends past the edge of the crimp tool.

Figure 56: Positioning the Connector in the Crimp Tool

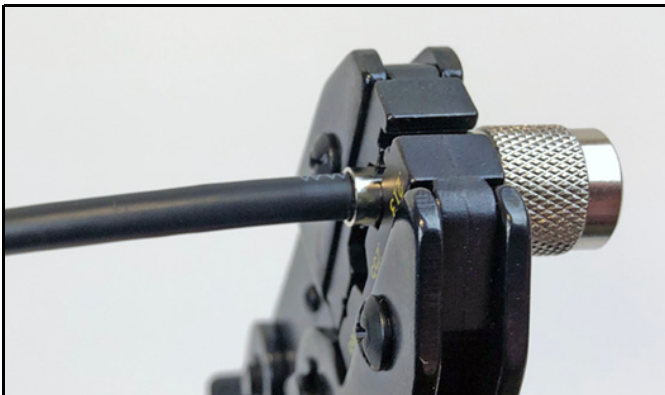

12. Crimp the ferrule in place. **Crimp only once.**

Figure 57: Crimping the Ferrule onto the Cable



Figure 58: Connector Properly Crimped in Place

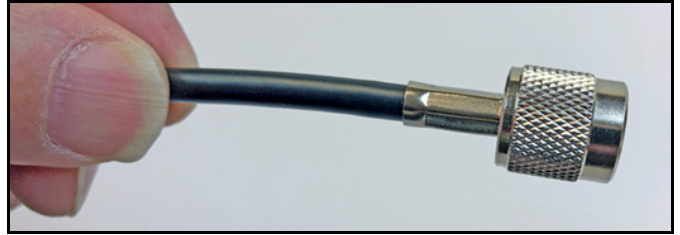

13. Push the rubber boot up the cable until it covers the entire ferrule.

Figure 59: Rubber Boot in Place Over Ferrule



14. Using a multimeter or similar device, check the continuity of the cable and make sure the center conductor is not shorted to the shield.

Appendix B:

Wiring the Antenna Using a Preinstalled Cable

You can connect the antenna to the VSAT-Hub using a preinstalled 75Ω RG-11, LMR-400, or LMR-600 RF cable, as long as the cable is clean, free of rust or corrosion, meets all of the criteria in [“Prepare the Antenna Cable” on page 9](#), is inspected and approved by a KVH-authorized technician, and does not exceed the maximum length below.

Note: If you would like to use a different preinstalled cable (e.g., RG-6 or RG-209), contact KVH Technical Support (see [“Technical Support” on page 1](#)).

Figure 60: Preinstalled RF Cable Options

Cable Type	Max. Length
RG-11	100 ft (30 m)
LMR-400-75	300 ft (90 m)
LMR-600-75	400 ft (120 m)

Although you may reuse the cable, you cannot connect it directly to the new antenna and VSAT-Hub; they have TNC connectors rather than F-type connectors. In addition, the stiffness of these cable types can overstress the connector on the VSAT-Hub. Therefore, you will need to use the pigtail cables as explained in [“Connecting Pigtail Cables to the Antenna Cable” on page 32](#).

Appendix C:

Connecting Pigtail Cables to the Antenna Cable

Pigtail cables are required in the following circumstances:

- If you are using RG-11, LMR-400, or LMR-600 cable, connect a pigtail cable between it and the VSAT-Hub's TNC connector. You cannot connect one of these stiff cables directly to the VSAT-Hub. *You might use a pigtail cable at the antenna end as well to make it easier to maintain proper bend radius.*
- If you are reusing a preinstalled cable that has F-type or N-type connectors, use pigtail cables to convert to TNC connectors.

Three types of pigtail cables are available from KVH to accommodate different connectors (see Figure 61). All pigtail cables are 3 ft (1 m) in length. Be sure to order two if you need to connect one at each end of the antenna cable.

Figure 61: Pigtail Cables

Pigtail Cable	KVH Part No.
F-type (female) to TNC (male)	32-1440-003F
N-type (female) to TNC (male)	32-1440-003N
TNC (female) to TNC (male)	32-1440-003T

Follow the steps below to connect a pigtail cable to the antenna cable.

1. Slide a heat shrink sleeve onto the end of each pigtail cable (opposite the antenna or VSAT-Hub end) for later use. *The heat shrink will protect the connection between the antenna cable connector and the pigtail cable connector.*
2. Fill half of the inner body of the antenna cable connector with the supplied silicone grease to prevent moisture and corrosion.
3. Connect and **SLOWLY** hand-tighten the male antenna cable connector to the female connector end of the pigtail cable, allowing the grease to diffuse and settle into the entire space within the connector.
4. Make sure the antenna cable connector is tightened all the way into the pigtail cable's connector. For N-type and TNC connectors, hand-tightening is sufficient. For F-type connectors, use as 7/16" torque wrench set to 20 in-lbs.
5. Seal the antenna cable-to-pigtail connection using self-vulcanizing tape or equivalent. Then protect the connection with the heat shrink.

6. Repeat these steps for each pigtail, then continue system installation by referring back to "Wire the Antenna" on page 10.

Figure 62: Connecting the Antenna Cable to the Pigtail Cable

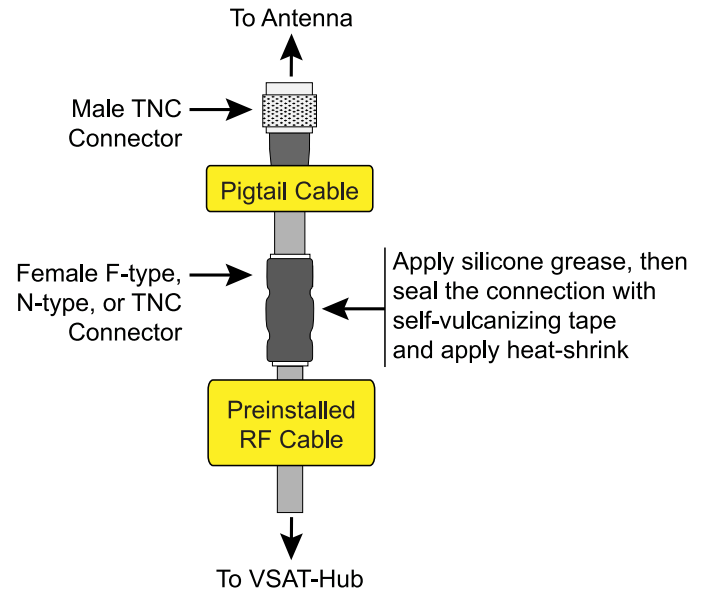

Appendix D: Verifying the NMEA 0183 Message

Verify the message supplied by the NMEA 0183 talker by connecting its output to a laptop using an RS422-to-USB adapter cable and viewing its data stream using PuTTY, HyperTerminal, or other terminal emulator.

IMPORTANT!

To verify NMEA 2000 messaging, refer to the instructions that came with your NMEA 2000 talker.

Follow these instructions to verify the message.

Note: These example instructions assume you will be using PuTTY.

1. Using an RS422-to-USB adapter, connect the NMEA 0183 talker to the adapter's RS422 input. Then connect the adapter to the laptop's USB port.

Figure 63: Connecting a NMEA 0183 Talker to a Laptop

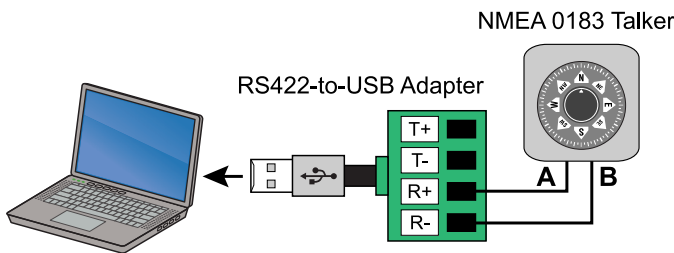

2. Start PuTTY and specify the laptop's port, connection type, and baud rate.

Figure 64: Starting PuTTY Options (Example)

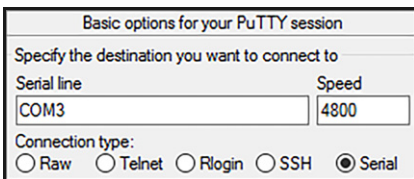

3. Configure options at the **Serial** configuration menu as follows:
 - 4800 baud
 - 8 data bits
 - 1 stop bit
 - no parity
 - no flow control

Figure 65: PuTTY Port Configuration Options (Example)

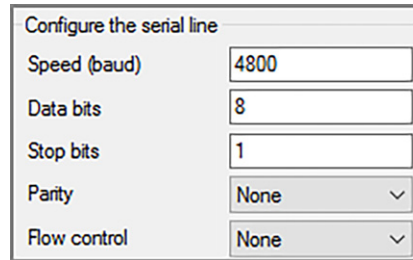

4. Select **Open** to view the message data in a command line window.

Figure 66: PuTTY Command Line Window (Example)

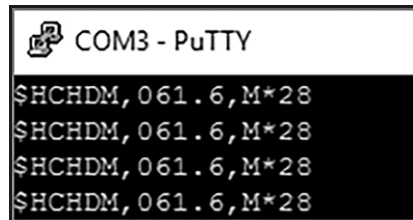

Appendix E: Wiring Diagram

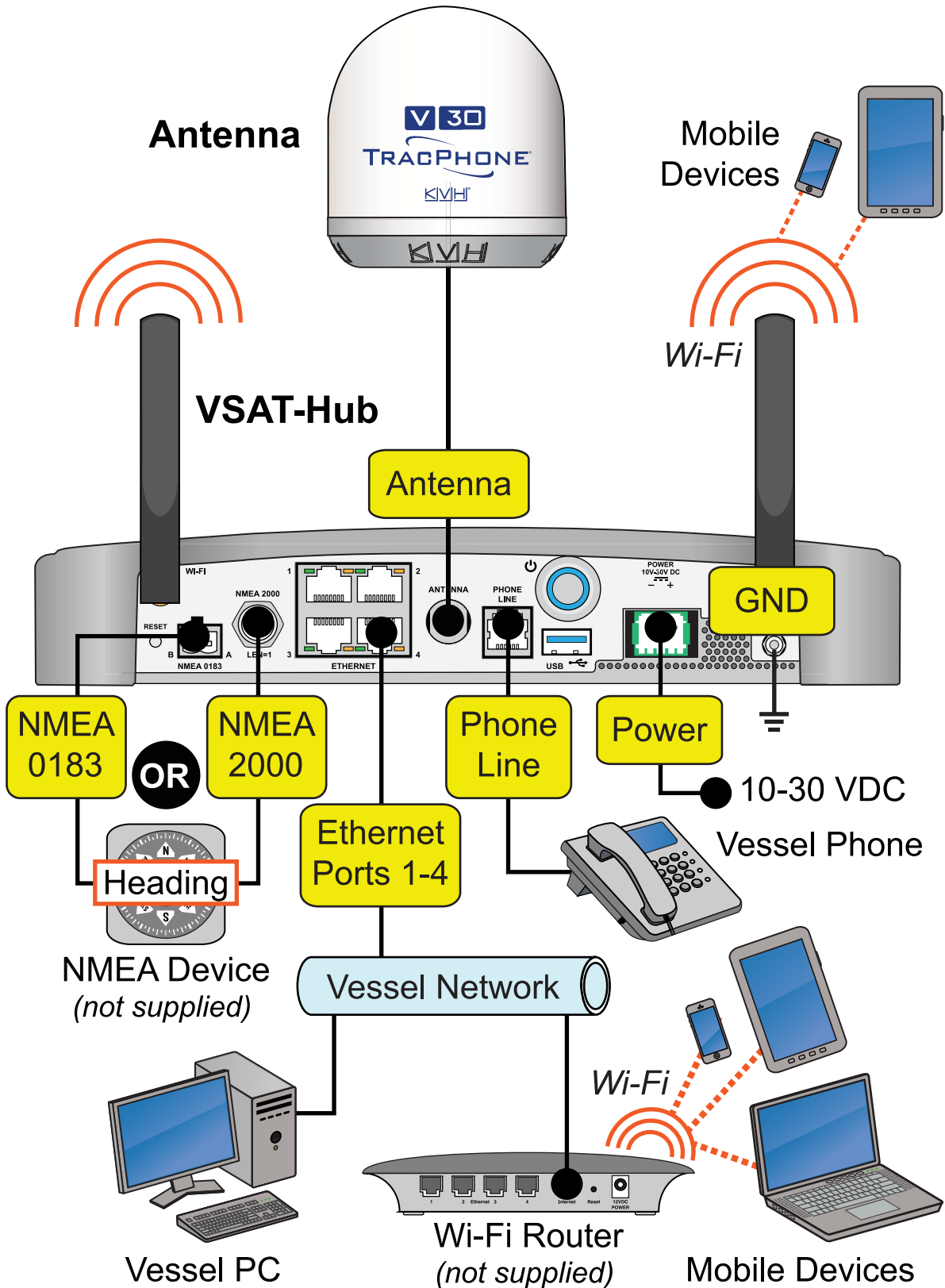



Regulatory Compliance

European Union Compliance

Hereby, KVH Industries, Inc. declares that the radio equipment type TracPhone V30 is in compliance with Directive 2014/53/EU. For the full text of the EU Declaration of Conformity, go to www.kvh.com/euconformity.

Federal Communications Commission Compliance



The TracPhone system complies with Class B of Part 15 of the FCC (Federal Communications Commission) rules for radiated and conducted emissions.

FCC Identifiers: RYK-WNFQ261ACNIBT (VSAT-Hub Wi-Fi)

Use Conditions:

This device complies with part 15 of the FCC Rules. Operation is subject to the following two conditions:

1. This device may not cause harmful interference.
2. This device must accept any interference received, including interference that may cause undesired operation.

Note:

This equipment has been tested and found to comply with the limits for a Class B digital device, pursuant to Part 15 of the FCC Rules. These limits are designed to provide reasonable protection against harmful interference in a residential installation. This equipment generates, uses, and can radiate radio frequency energy and, if not installed and used in accordance with the instructions, may cause harmful interference to radio communications. However, there is no guarantee that interference will not occur in a particular installation. To determine if the equipment is interfering with radio or television reception, remove or apply power to the equipment and observe if the interference goes away, or returns, when the unit is off or on. The user is encouraged to try to correct the interference by one of the following measures:

- Reorient or relocate the receiving antenna.
- Increase the separation between the equipment and receiver.
- Connect the equipment into an outlet on a circuit different from that to which the receiver is connected.
- Consult KVH for assistance.

IMPORTANT:

- To meet FCC requirements, shielded Ethernet cables are required to connect the VSAT-Hub to the ship's network.
- This equipment contains no user serviceable parts. Opening this unit will violate the warranty and may result in this equipment no longer complying with FCC requirements for Class B digital devices.



CE



www.kvh.com



KVH Industries A/S
EMEA Headquarters
Kokkedal, Denmark
Tel: +45 45 160 180 Fax: +45 45 160 181
E-mail: info@emea.kvh.com

KVH Industries, Inc.
World Headquarters
Middletown, RI U.S.A.
Tel: +1 401 847 3327 Fax: +1 401 849 0045
E-mail: info@kvh.com

KVH Industries Pte Ltd.
Asia-Pacific Headquarters
Singapore
Tel: +65 6513 0290 Fax: +65 6472 3469
E-mail: info@apac.kvh.com