

Smart choice for power™

**xantrex**<sup>™</sup>  
A MISSION CRITICAL ELECTRONICS BRAND

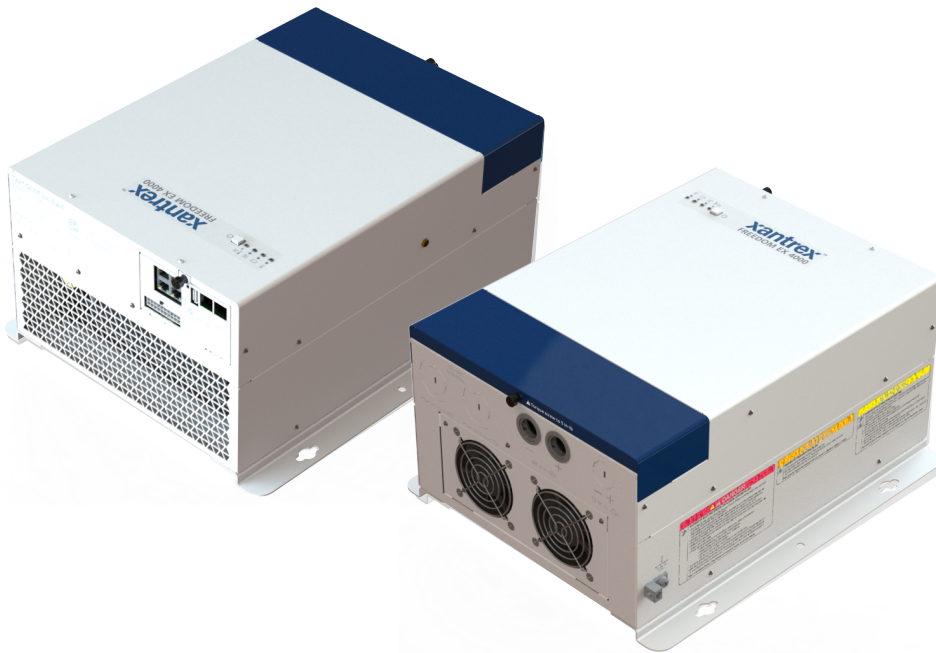

## Installation Guide

# Freedom EX 4000 Inverter/Charger with 48VDC-to- 12VDC Converter

Freedom EX 4000  
PN: 820-4080-41

---

Copyright © 2019-2021 Xantrex LLC. All Rights Reserved.  
All trademarks are owned by Xantrex LLC and its affiliates.

**Exclusion for Documentation**

UNLESS SPECIFICALLY AGREED TO IN WRITING, SELLER

(A) MAKES NO WARRANTY AS TO THE ACCURACY, SUFFICIENCY OR SUITABILITY OF ANY TECHNICAL OR OTHER INFORMATION PROVIDED IN ITS MANUALS OR OTHER DOCUMENTATION;

(B) ASSUMES NO RESPONSIBILITY OR LIABILITY FOR LOSSES, DAMAGES, COSTS OR EXPENSES, WHETHER SPECIAL, DIRECT, INDIRECT, CONSEQUENTIAL OR INCIDENTAL, WHICH MIGHT ARISE OUT OF THE USE OF SUCH INFORMATION. THE USE OF ANY SUCH INFORMATION WILL BE ENTIRELY AT THE USER'S RISK; AND

(C) REMINDS YOU THAT IF THIS MANUAL IS IN ANY LANGUAGE OTHER THAN ENGLISH, ALTHOUGH STEPS HAVE BEEN TAKEN TO MAINTAIN THE ACCURACY OF THE TRANSLATION, THE ACCURACY CANNOT BE GUARANTEED. APPROVED CONTENT IS CONTAINED WITH THE ENGLISH LANGUAGE VERSION WHICH IS POSTED AT <http://www.xantrex.com/>.

**NOTE:** Visit <http://www.xantrex.com/> , click Products, select a Product category, select a Product, and search the Product Documents panel for a translation of the English guide, if available.

**Document Number:** 975-0998-01-01      **Rev D**      **Date:** September 2021

**Product Name and Part Number**

Freedom EX 4000 (820-4080-41)

**Contact Information**

**Telephone:** (Toll Free USA/Canada) +1 800 670 0707 / (Outside USA/Canada) +1 408 987 6030

**Email:** [customerservice@xantrex.com](mailto:customerservice@xantrex.com),  
<http://www.xantrex.com/power-products-support/>

**Web:** <http://www.xantrex.com/>

**Information About Your System**

As soon as you open your product, record the following information and be sure to keep your proof of purchase.

Serial Number \_\_\_\_\_

Product Number \_\_\_\_\_

Purchased From \_\_\_\_\_

Purchase Date \_\_\_\_\_

To view, download, or print the latest revision, visit the website shown under **Contact Information**.

---

## Purpose

The purpose of this Installation Guide is to provide explanations and procedures for installing a Freedom EX 4000 Inverter/Charger with 48VDC-to-12VDC Converter for Recreational, Commercial and Fleet Vehicle, or Marine installations.

## Scope

The guide provides safety guidelines as well as information on installing the inverter/charger/converter. It does not provide details about particular brands of batteries. You need to consult individual battery manufacturers for this information.

## Audience

The guide is intended for qualified personnel.

Qualified personnel have training, knowledge, and experience in:

- Installing electrical equipment (up to 1000 V).
- Applying all applicable installation codes.
- Analyzing and reducing the hazards involved in performing electrical work.
- Installing and configuring batteries (especially lithium-ion batteries, as applicable)
- Selecting and using Personal Protective Equipment (PPE) and following safety work code practices. See NFPA 70E or CSA Z462.

## Abbreviations and Acronyms

A	Amperes
Ah	Amp-hours (a unit of battery capacity)
AC	Alternating Current [~]
AGM	Absorbed Glass Mat (a battery type)
BTS	Battery Temperature Sensor
CAN	Controller Area Network
CVCC	Constant Voltage Constant Current
DC	Direct Current [—]
GFCI	Ground Fault Circuit Interrupter
h	Hours (a unit of time)
Hz	Hertz (a unit of frequency)
in-lb	inch-pound force (a unit of torque)
kW	Kilowatts (1000 watts)
LBCO	Low Battery Cutout (or Cutoff)
LCD	Liquid Crystal Display
LED	Light Emitting Diode
LFP	LiFePO <sub>4</sub> (lithium iron phosphate – a battery type)
m	Minutes (a unit of time)
max	Maximum
min	Minimum
ms	Milliseconds (a unit of time)

N-m	Newton-meters (a unit of torque)
PN	Product Number
PPE	Personal Protective Equipment
RV-C	Recreational Vehicle CAN Bus Communications protocol
s	Seconds (a unit of time)
SPD	Surge Protection Device
TVSS	Transient Voltage Surge Suppressor
V, VAC, VDC	Voltage, Volts AC, Volts DC
W	Wattage, watt (a unit of power)
°	Degrees symbol commonly used for temperature
°C	Unit of degrees in Celsius scale
°F	Unit of degrees in Fahrenheit scale
%	Percent, percentage

## Related Information

You can find more information about Xantrex products and services at <http://www.xantrex.com/>.

# Important Safety Information

READ AND SAVE THIS INSTALLATION GUIDE FOR FUTURE REFERENCE.

This guide contains important safety instructions for the Freedom EX 4000 that must be followed during installation, maintenance, and troubleshooting.

Read these instructions carefully and look at the equipment to become familiar with the device before installing it. The following special messages may appear throughout this documentation or on the equipment to warn of potential hazards or to call attention to information that clarifies or simplifies a procedure.



The addition of either symbol to a "Danger" or "Warning" safety label indicates that an electrical hazard exists which will result in personal injury if the instructions are not followed.



This is the safety alert symbol. It is used to alert you to potential personal injury hazards. Obey all safety messages that follow this symbol to avoid possible injury or death.

## DANGER

**DANGER** indicates a hazardous situation which, if not avoided, **will result in** death or serious injury.

## WARNING

**WARNING** indicates a hazardous situation which, if not avoided, **could result in** death or serious injury.

## CAUTION

**CAUTION** indicates a hazardous situation which, if not avoided, **could result in** minor or moderate injury.

## NOTICE

**NOTICE** is used to address practices not related to physical injury.

### Please Note

No responsibility is assumed by Xantrex for any consequences arising out of the use of this material.

### Product Safety Information

1. Before using the inverter/charger/converter, read all instructions and cautionary markings on the unit, the batteries, and all appropriate sections of this guide.
2. Use of accessories not recommended or sold by the manufacturer may result in a risk of fire, electric shock, or injury to persons.

3. The inverter/charger/converter is designed to be connected to both DC and AC electrical systems. The manufacturer recommends that all wiring be done by a certified technician or electrician to ensure adherence to the local and national electrical codes applicable in your jurisdiction.
4. To avoid a risk of fire and electric shock, make sure that existing wiring is in good condition and that wire is not undersized. Do not operate the inverter/charger/converter with damaged or substandard wiring.
5. Do not operate the inverter/charger/converter if it has been damaged in any way.
6. This unit does not have any user-serviceable parts. Do not disassemble the inverter/charger/converter except where noted for connecting wiring and cabling. See your warranty for instructions on obtaining service. Attempting to service the unit yourself may result in a risk of electrical shock or fire. Internal capacitors remain charged after all power is disconnected.
7. To reduce the risk of electrical shock, disconnect both AC and DC power to or from the inverter/charger/converter before attempting any maintenance or cleaning or working on any components connected to the inverter/charger/converter. Do not disconnect under load. Turning the inverter/charger/converter to Standby using the Power button on the front panel will not reduce an electrical shock hazard.
8. The inverter/charger/converter must be provided with an equipment-grounding conductor connected to the AC input ground.
9. Do not expose this unit to rain, snow, or liquids of any type. This product is designed for dry-locations-use only. Damp environments will significantly shorten the life of this product and corrosion caused by dampness will not be covered by the product warranty.
10. To reduce the chance of short-circuits, always use insulated tools when installing or working with this equipment.
11. Remove personal metal items such as rings, bracelets, necklaces, and watches when working with electrical equipment.
12. For marine applications, this unit must be installed with a drip shield. Refer to *Drip Shield Installation* for details.

## DANGER

### ELECTRICAL SHOCK AND FIRE HAZARD

Installation must be done by qualified personnel to ensure compliance with all applicable installation and electrical codes and regulations. Instructions for installing the Freedom EX 4000 Inverter/Charger with 48VDC-to-12VDC Converter are provided here for use by qualified personnel only.

**Failure to follow these instructions will result in death or serious injury.**

## **⚠ DANGER**

### **HAZARD OF ELECTRIC SHOCK, EXPLOSION, BURN, OR ARC FLASH**

- Apply appropriate personal protective equipment (PPE) and follow safe electrical work practices. See NFPA 70E or CSA Z462.
- This equipment must only be installed and serviced by qualified electrical personnel.
- Turn off all power supplying this equipment before working on or inside equipment.
- Always use a properly rated voltage sensing device to confirm power is off.
- Replace all devices, doors, and covers before turning on power to this equipment.
- Batteries can present a risk of electrical shock, high short-circuit current, and exposure to gasses and chemicals.
- Observe the following precautions when working with batteries:
  - Remove watches, rings, or other metal objects;
  - Keep sparks and flames away from batteries;
  - Use tools with insulated handles;
  - Do not lay tools or other metal parts on top of batteries.
- Servicing of batteries must only be performed by qualified personnel knowledgeable of batteries and the required precautions. Keep unqualified personnel away from batteries.
- Disconnect the charging source prior to connecting or disconnecting battery terminals.
- Never attempt to charge a frozen battery.

**Failure to follow these instructions will result in death or serious injury.**

## **⚠ WARNING**

### **FIRE AND EXPLOSION HAZARD**

- Unit's components may produce arcs or sparks.
- Do not install near batteries, in machinery space, or in an area in which ignition-protected equipment is required.
- For indoor use only.

**Failure to follow these instructions can result in death, serious injury, or equipment damage.**

Areas include any space containing gasoline-powered machinery, fuel tanks, as well as joints, fittings, or other connections between components of the fuel system.

## **⚠ WARNING**

### **HEAVY EQUIPMENT**

Always use proper lifting techniques during handling and installation. A two-person lift is required to prevent personal injury.

**Failure to follow these instructions can result in death, serious injury, or equipment damage**

## **⚠ WARNING**

### **ELECTRICAL SHOCK HAZARD**

- Replace the wiring compartment cover before turning on power to this equipment.
- Use a torque screwdriver to tighten the captive nut panel screw to 5 in-lb (0.56 N-m) torque to ensure a proper ground connection and a required tool access to the wiring compartment.

**Failure to follow these instructions can result in death, serious injury, or equipment damage.**

## **⚠ CAUTION**

### **HAZARD OF ELECTRICAL SHOCK AND FIRE**

- Do not open. No serviceable parts inside. Provided with integral protection against overloads. Bonding between conduit connections is not automatic and must be provided as part of the installation.
- Read manual before installing or using.
- Do not cover or obstruct ventilation openings.
- Do not mount in zero-clearance compartment – overheating may result.
- Do not expose to rain or spray.
- Install GFCI protection of branch circuits connected to the AC output per electrical code requirements.
- Do not connect AC OUT to any other source of power. Damage to unit may occur.
- For AC IN and AC OUT, use wires suitable for at least 75°C.

**Failure to follow these instructions can result in minor or moderate injury.**

### **NOTES:**

1. Follow these instructions and those published by the battery manufacturer and the manufacturer of any equipment you intend to use in the vicinity of the battery. Review cautionary markings on these products and on the engine.
2. Freedom EX 4000 Inverter/Charger with 48VDC-to-12VDC Converter products are designed for deep cycle lead-acid batteries. See warning below when connecting to lithium ion batteries.
3. Do not use transformerless battery chargers in conjunction with the inverter/charger/converter due to overheating.

**⚠ CAUTION**

**LITHIUM ION BATTERY TYPE HAZARD**

Make sure to use a lithium ion battery pack that includes a certified Battery Management System (BMS) with built-in safety protocols including a pre-charge contactor (see NOTE below). Follow the instructions published by the battery manufacturer.

**Failure to follow these instructions can result in serious injury or equipment damage.**

**NOTE:** A pre-charge circuit is a featured built-in contactor by some battery manufacturers which regulates inrush current from the inverter's capacitors allowing a smooth transition into full power system operation.

**⚠ CAUTION**

**PHYSICAL INJURY HAZARD**

This Freedom EX 4000 Inverter/Charger with 48VDC-to-12VDC Converter is not intended for use by persons (including children) with reduced physical, sensory, or mental capabilities or lack of experience and knowledge, unless they have been given supervision or instruction concerning use of the appliance by a person responsible for their safety. Children should be supervised to ensure that they do not play with the appliance.

**Failure to follow these instructions can result in injury or equipment damage.**

**Precautions When Working With Batteries**

**IMPORTANT:** Battery work and maintenance must be done by qualified personnel knowledgeable about batteries to ensure compliance with battery handling and maintenance safety precautions.

**⚠ WARNING**

**BURN FROM HIGH SHORT-CIRCUIT CURRENT, FIRE AND EXPLOSION FROM VENTED GASES HAZARDS**

- Always wear proper, non-absorbent gloves, complete eye protection, and clothing protection. Avoid touching your eyes and wiping your forehead while working near batteries. See note #4.
- Remove all personal metal items, like rings, bracelets, and watches when working with batteries. See notes #5 and #6 below.
- Never smoke or allow a spark or flame near the engine or batteries.
- Never charge a frozen battery.
- Never charge a Lithium Ion type battery with an ambient of 0 °C (-32 °F) or colder.

**Failure to follow these instructions can result in death, serious injury, or equipment damage.**

**NOTES:**

1. Mount and place the Freedom EX 4000 Inverter/Charger with 48VDC-to-12VDC Converter unit away from batteries in a well ventilated compartment.
2. Always have someone within range of your voice or close enough to come to your aid when you work near a lead-acid battery.
3. Always have plenty of fresh water and soap nearby in case battery acid contacts skin, clothing, or eyes.
4. Keep battery terminals clean from corrosion. If battery acid or corrosion deposit contacts skin or clothing, wash immediately with soap and water. If battery acid or corrosion deposit enters your eye, immediately flood it with running cold water for at least twenty minutes and have someone within range of your voice or close enough to get medical attention immediately.
5. Use extra caution to reduce the risk of dropping a metal tool on the battery. It could spark or short circuit the battery or other electrical parts and could cause an explosion. Use tools with insulated handles only.
6. Batteries can produce a short circuit current high enough to weld a ring or metal bracelet or the like to the battery terminal, causing a severe burn.
7. When removing a battery, always remove the negative terminal from the battery first for systems with grounded negative. Only use this unit in a negative (-) grounded system. This unit is not designed for a positive (+) grounded system. Make sure all loads connected to the battery and all accessories are off so you don't cause an arc.

**Precautions When Placing the Unit**

**⚠ WARNING**

**FIRE HAZARD**

- Do not install the inverter/charger/converter or any part of its supplied wiring in engine compartments.
- For marine installation, always locate the inverter/charger/converter away from the battery and mounted separately in a well-ventilated compartment with adequate space.

**Failure to follow these instructions can result in death, serious injury, or equipment damage.**

**⚠ CAUTION**

**BURN HAZARD**

Avoid touching the external surfaces as they may be hot.

**Failure to follow these instructions can result in injury or equipment damage.**

## NOTICE

### RISK OF INVERTER/CHARGER/CONVERTER DAMAGE

- Never allow battery acid to drip on the inverter/charger/converter when reading specific gravity, or filling battery.
- Never place the Freedom EX 4000 unit directly above batteries; gases from a battery will corrode and damage the inverter/charger/converter.
- Do not place a battery on top of the inverter/charger/converter.

**Failure to follow these instructions can result in equipment damage.**

## Regulatory

The Freedom EX 4000 inverter/charger/converter is certified to appropriate US and Canadian standards. For more information see *Regulatory approvals on page 48*.

The Freedom EX 4000 inverter/charger/converter is intended to be used for recreational, commercial, or other mobile applications. This inverter/charger/converter is designed for marine applications only when additional drip protection is installed in certain orientations. See the section on Marine Installation for information.

## FCC (EMI) Information to the User

This equipment has been tested and found to comply with the limits for a Class B digital device, pursuant to part 15 of the FCC / CAN ICES-003 Rules. These limits are designed to provide reasonable protection against harmful interference in a residential environment. This equipment generates, uses, and can radiate radio frequency energy and, if not installed and used in accordance with the instructions, may cause harmful interference to radio communications.

However, there is no guarantee that interference will not occur in a particular installation. If this equipment does cause harmful interference to radio or television reception, which can be determined by turning the equipment off and on, the user is encouraged to try to correct the interference by one or more of the following measures:

- Reorient or relocate the receiving antenna.
- Increase the separation between the equipment and receiver.
- Connect the equipment into an outlet on a circuit different from that to which the receiver is connected.
- Consult the dealer or an experienced radio/TV technician for help.

## CAUTION

Unauthorized changes or modifications to the equipment could void the user's authority to operate the equipment.

## End of Life Disposal

The Freedom EX 4000 Inverter/Charger with 48VDC-to-12VDC Converter is designed with environmental awareness and sustainability in mind. At the end of its useful life, the Freedom EX 4000 can be decommissioned and disassembled.

Components which can be recycled must be recycled and those that cannot be recycled must be disposed of according to local, regional, or national environmental regulations.

Many of the electrical components used in the Freedom EX 4000 Inverter/Charger with 48VDC-to-12VDC Converter are made of recyclable material like steel, copper, aluminum, and other alloys. These materials can be auctioned off to traditional scrap metal recycling companies who resell reusable scraps.

Electronic equipment such as the circuit boards, connectors, and fuses can be broken down and recycled by specialized recycling companies whose goal is to avoid having these components end up in the landfill.

For more information on disposal, contact Xantrex.



This page is intentionally left blank. [2]

---

# Contents

Important Safety Information .....	2
Precautions When Working With Batteries .....	4
Precautions When Placing the Unit .....	4
Regulatory .....	5
FCC (EMI) Information to the User .....	5
End of Life Disposal .....	5
Materials List .....	9
Before You Begin the Installation .....	9
Installation Codes .....	9
Installation Tools and Materials .....	10
Basic Installation Procedures .....	10
Step 1: Designing the Installation .....	11
Step 2: Choosing a Location for the Unit .....	16
Step 3: Mounting the Unit .....	16
Step 4: Connecting the AC Input Wires .....	18
Step 5: Connecting AC Output to an Existing AC Circuit .....	21
Step 6: Connecting the DC Cables .....	31
Step 7: Connecting to Port(s) on the Freedom EX 4000 .....	37
Step 8: Battery Configuration .....	41
Step 9: Testing Your Installation .....	41
Marine Installation .....	43
Drip Shield Installation .....	44
Physical Specifications .....	45
Environmental Specifications .....	46
System Specifications .....	46
Regulatory Approvals .....	48



This page is intentionally left blank. [1]



## Materials List

The Freedom EX 4000 base package includes the following items.

1	Freedom EX 4000
2	Installation guide
3	pair of 1/2" bushings
4	pair of 3/4" bushings
5	one network terminator

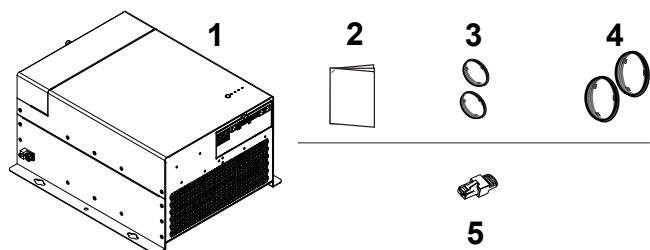

Figure 1 Materials List

**NOTE:** If any of the items are missing, contact Xantrex or any authorized Xantrex dealer for replacement. See *Accessories* on page 47.

**IMPORTANT:** Keep the carton and packing material in case you need to return the inverter/charger/converter for servicing.

## Before You Begin the Installation

Before beginning your installation:

- Read this entire Installation guide so you can plan the installation from beginning to end.
- Assemble all the tools and materials you require for the installation.
- Review the *Safety Information* on page 1.
- Be aware of all safety and electrical codes which must be met.

### **⚠ WARNING**

#### **ELECTRICAL SHOCK AND FIRE HAZARD**

- All wiring should be done by qualified personnel to ensure compliance with all applicable installation codes and regulations.
- Do not connect to AC and DC power sources during installation. Disconnect from all power sources when servicing.
- Disable and secure all AC and DC disconnect devices and automatic generator starting devices.

**Failure to follow these instructions can result in death, serious injury, or equipment damage**

## Installation Codes

Governing installation codes vary depending on the specific location and application of the installation. Some examples include the following:

- The U.S. National Electrical Code (NEC)
- The Canadian Electrical Code (CEC)
- The U.S. Code of Federal Regulations (CFRs)
- Canadian Standards Association/CSA Group (CSA) and the RV Industry Association (RVIA) standards and codes for installations in RVs
- The American Boat and Yacht Council (ABYC) standards and US Coast Guard Regulations (33CFR183, Sub Part I) for Marine installations in the U.S.

It is the installer's responsibility to ensure that all applicable installation requirements are met.

## Installation Tools and Materials

You will need the following to install the Freedom EX 4000:

- Wire/cable stripper
- 1/2" screws or bolts for mounting vertically
- #2 Phillips torque screwdriver
- Torque wrench for DC terminals (1/2" or 13mm socket wrench)
- AC cable (that is, three-conductor-plus-ground cable), sized appropriately for load and application
- 1/2" (or 3/4") trade-size bushings (supplied)
- ferrite cores (supplied)
- 1/2" (or 3/4") trade-size strain relief device (optional)
- Wire nuts or crimp connectors for AC wire and appropriate tools and also if installing the 20-pin harness (PN: 808-0820, sold separately)
- DC cable, sized appropriately for battery and load (more on page 1)
- Lugs for DC cables to fit 5/16" DC stud terminals as well as appropriate tools (like a crimping tool)
- AC and DC disconnects and over-current protective devices, as appropriate
- Drip shields (not supplied) for Marine installations. See *Drip Shield Installation on page 44*.

## Basic Installation Procedures

This section provides sample installation information as a guide for your installation. For your convenience, the overall procedure is divided into these main steps:

<b>Step 1: Designing the Installation</b> .....	<b>11</b>
<b>Step 2: Choosing a Location for the Unit</b> .....	<b>16</b>
<b>Step 3: Mounting the Unit</b> .....	<b>16</b>
<b>Step 4: Connecting the AC Input Wires</b> .....	<b>18</b>
<b>Step 5: Connecting AC Output to an Existing AC Circuit</b>	<b>21</b>
<b>Step 6: Connecting the DC Cables</b> .....	<b>31</b>
<b>Step 7: Connecting to Port(s) on the Freedom EX 4000</b> ..	<b>37</b>
<b>Step 8: Battery Configuration</b> .....	<b>41</b>
<b>Step 9: Testing Your Installation</b> .....	<b>41</b>

**NOTE:** For marine applications, see additional installation instructions on page 43.

## Step 1: Designing the Installation

Most Freedom EX 4000 installations share common components, and some of these are briefly described below.

Figure 2 shows some components and their relationship to each other in a typical recreational vehicle or fleet vehicle installation. Also, see *Marine Installation* on page 43.

Figure 2 Typical Recreational Vehicle and Fleet Vehicle Installation

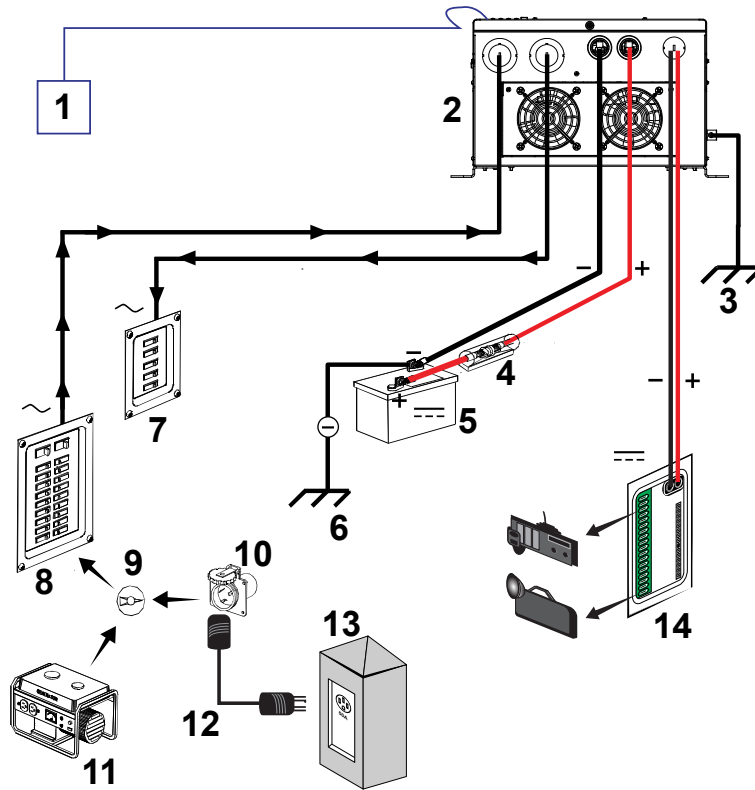

1	Communications and Control 20-pin Harness
2	Freedom EX 4000
3	Equipment ground
4	DC fuse/disconnect/DC circuit breaker
5	48V deep cycle battery (house)
6	Equipment ground (vehicle chassis)
7	AC inverter load panel
8	AC source shore panel
9	Selector switch
10	Shore power receptacle
11	Generator
12	RV dogbone adapter and/or power extension cord
13	Camp site power panel with electrical receptacles
14	12VDC load sub-panel

**⚠ DO NOT CONNECT DC LOAD SUB-PANEL NEG(-) TO VEHICLE CHASSIS.**  
**NOTE:** The NEG(-) 48V and 12V are bonded internally.

## AC Shore Power

A source of 120 volts AC 60Hz (single-phase) and 240 volts AC 60Hz (split-phase) sine wave alternating current provides energy to pass power through to AC loads. This source is usually the utility grid (power company) or an AC generator. An automatic or manual AC source selector switch can be used to switch between the multiple sources of shore power to the Freedom EX 4000 system.

The AC source feeding the Freedom EX 4000 must have the neutral conductor bonded to ground. When the inverter/charger/converter is in pass-through mode, it will lift its internal bonding relay on the output as it passes shore power through and will rely on the input neutral being bonded in order to ensure that the power delivered to a sub panel is properly bonded. See *AC Output Neutral Bonding on page 13* for more information on bonding relay operation.

**NOTE:** Throughout this guide, the term “shore power” refers to AC input power from a utility grid, generator, or other AC source.

## AC Disconnect and Over-Current Protection Device

Most safety requirements and electrical codes require the Freedom EX 4000’s AC and DC inputs and outputs to be provided with over-current protection (such as circuit breakers or fuses) and disconnect devices.

**AC Input** The circuit breaker or fuse (connected through hard wiring) that is used to supply the Freedom EX 4000 must be rated at no more than 50A and must be approved for use on 120 volts AC branch circuits. The wire used between the breaker and the Freedom EX 4000 input must be sized adequately to carry current up to the rating of the input breaker and in accordance with the electrical codes or regulations applicable to your installation.

**AC Output** The circuit breaker or fuse must be rated at no more than the rating of the input breaker in the installation and must be approved for use on 120 volts AC branch circuits. The wire used between the Freedom EX 4000 and the AC output breaker must be of adequate size to match the AC input circuit breaker’s rating. The wiring from each AC output breaker to each of the loads must be adequately sized to carry the current rating of the individual AC output breaker.

**Disconnect Devices** Each system requires a method of disconnecting the AC circuits. If the over-current protection devices are circuit breakers, they will also serve as the disconnects. If fuses are used, separate AC disconnect switches will be needed ahead of the fuses. These will have to be a branch circuit rated for 120 volts AC and have an appropriate current rating.

## Surge Arrester

In a marine installation, each system requires a separate method of protecting the AC circuits from a transient over-voltage, also called a spike or short duration electrical surge. This protection device is often referred to as a surge protection device (SPD) or transient voltage surge suppressor (TVSS). An SPD or TVSS must be mounted on the vessel’s AC circuit breaker panel according to marine electrical codes or regulations.

## AC Distribution Panels

Most systems incorporate distribution centers both ahead of the Freedom EX 4000 (the AC source panel) and between the Freedom EX 4000 and the loads (the AC load panel). An AC source panel includes a main circuit breaker, which serves as over-current protection and as a disconnect for the AC shore power supply line. Additional circuit breakers serve individual circuits, one of which serves the Freedom EX 4000. The AC load panel can incorporate an AC output circuit breaker and breakers for individual load circuits.

## AC Cabling

AC cabling includes all the wires and connectors between the AC source and the Freedom EX 4000, as well as all AC cabling between the Freedom EX 4000 and the AC output panels, circuit breakers, and loads. The type and size of the wiring varies with the installation and load. For example, in high vibration environments, such as marine or RV applications, wire nuts may not be acceptable, so crimp splices would be required. In other applications, flexible multiple-strand wire may be required. Installation codes usually specify solid or stranded, overall size of the conductors, and type and temperature rating of the insulation around the wire.

AC breakers and fuses must be sized to adequately protect the wiring that is installed on the input and output AC circuits of the Freedom EX 4000. All breakers and wiring must be sized and connected in accordance with the electrical codes or regulations applicable to your installation. *Table 1* gives some examples of wiring sizes based on the U.S. National Electrical Code and the Canadian Electrical Code. These examples are based on using a two-conductor-plus-ground copper cable rated at 60 °C, and assuming an ambient temperature of up to 30 °C. Ensure that your breakers and fuses have suitable temperature ratings for your wiring. Other codes and regulations may also be applicable to your installation.

*Table 1 Required AC Wire Size vs Breaker Rating*

Breaker Size (A)	10A	15A	20A	30A	40A	50A
Minimum Wire Size (AWG)	14AWG	14AWG	12AWG	10AWG	8AWG	6AWG

## AC Input

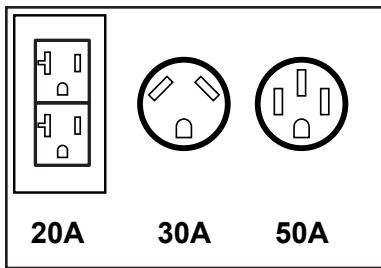

AC inputs to a dual AC line can be supplied from a split-phase or dual-input AC source such as the utility grid (power company), a generator, or the output of a transfer switch. The Freedom EX 4000 can be operated from the following types of 120 volt 60 Hz AC sources:

- **Split phase** which typically comes with a 50A outlet configuration
  - This source type has two lines (L1 and L2), one neutral (N), and one ground (G). The two 120 VAC lines (L1 and L2) are 180 degrees out of phase with each other, so that the two voltages total to 240 volts AC line to line. The voltage between each line and neutral is still 120 volts AC, and the voltage between the neutral and ground is approximately zero.
  - Because the two lines are out of phase, the currents from each line subtract in the neutral, and the neutral current will be approximately zero if the loads are equal. For example, if Line 1 is supplying 20 amps and Line 2 is supplying 15 amps, the current in the neutral will be 5 amps.
  - See *Figure 8 on page 23* for an illustration.
- **Dual input** which typically comes when a Dog Bone Adapter is used to plug to a 30A outlet configuration and then connected to a 50 A extension cord
  - This source type has two line inputs (L1 and L2), one neutral (N), and one ground (G). Unlike the split-phase type, the two lines are in phase (not out of phase), and must come from the same source. The voltage between the two lines is zero. The voltage between each line and the neutral is 120 volts AC, and the voltage between the neutral and ground is approximately zero.
  - Because the two lines are in phase, the currents from each line add together in the neutral. For example, if Line 1 is supplying 20 amps and Line 2 is supplying 15 amps, the current in the neutral will be 35 amps.
  - See *Figure 9 on page 23* for an illustration.
- **Single phase input** which is a typical outdoor 20A outlet configuration and also the 30A outlet configuration
  - This source type has one line input (AC qualification on L1 terminal only. Do not use L2 terminal), one neutral (N), and one ground (G).
  - See *Figure 10 on page 23* for an illustration.

## AC Output

The output voltage in Battery (Invert) mode on Freedom EX 4000 is 120 VAC, 60Hz.

- **Single AC Line** (L1) have a Single Input and Dual Output lines (L1 and L2) - (SI-DO) configuration. See *Figure 10 on page 23*.
- **Dual AC Line** (L1 and L2) support Dual Input and Dual Output lines (L1 and L2) - (DI-DO) configuration. See *Figure 8 and Figure 9 on page 23*.

### NOTE:

In Battery (Invert) mode, the unit provides Dual Output (DO). This means that the L1 and L2 output are in phase and only single line loads (120V loads) connected to either L1 or L2 output terminals get powered up. Split-phase (240V) loads are not powered up.

In Grid (pass through) mode, the AC output reflects whatever is at AC input. This means the following:

- if input is split-phase then the output is split-phase.
- if input is Dual Input (L1 and L2 in phase) then output is Dual Output (L1 and L2 in phase).
- if there is only single phase input at L1, then only L1 output is present.

## AC Output Neutral Bonding

The neutral conductor of the Freedom EX 4000's AC output circuit (that is, AC Output Neutral) is automatically connected to the safety ground during inverter operation. When AC utility power is present this connection is not present, so that the utility neutral (that is, AC Input Neutral) is only connected to utility ground at your source. This conforms to the National Electrical Code (NEC), which requires that separately derived AC sources (such as inverters and generators) have their neutral conductors tied to ground in the same way that the neutral conductor from the utility is tied to ground in only one place. Check the regulations for your specific application to ensure that the installation will comply with the necessary requirements. In other words, the AC Input Neutral ground bonding and Output Neutral ground bonding must be isolated from each other.

## AC Grounding

As per UL458 SA29.5 (d), for all permanently connected marine inverters: The Freedom EX 4000 should be connected to a grounded, metal, permanent wiring system. Also, make sure that an AC ground wire is connected to the AC ground terminal on the unit. Do not just connect the line and neutral wires. The AC ground conductor size must be equal to the AC supply conductor size for both the AC input and AC output connections.

All connections to the unit shall comply with all regulations, directives, local codes and ordinances.

## Ground Fault Circuit Interrupters (GFCIs)

A GFCI is a device that de-energizes a circuit when a current to ground exceeds a specified value that is less than that required to blow the circuit breaker. GFCIs are intended to protect people from electric shocks and are usually required in wet or damp locations.

Installations in marine and recreational vehicles require GFCI protection of branch circuits connected to the AC output of the Freedom EX 4000.

## DC Cabling (48VDC)

This includes all the cables and connectors between the batteries, the DC disconnect and over-current protection device, and the Freedom EX 4000. Most mobile installations require multi-strand insulated cables for flexibility and durability in high vibration environments and require disconnects and over-current devices. Electrical wiring sizes in North America are indicated by AWG notation. In other parts of the world, the metric system is used. Under the AWG standard, a larger gauge number indicates a smaller wire diameter. Wire size is usually marked on the larger sized cables. *Table 2* specifies the minimum recommended DC cable size and maximum fuse size for the Freedom EX 4000. **The DC cables must be stranded, copper, and must be rated 90 °C minimum.** The cables should be terminated with lugs that fit the DC stud terminals snugly (<sup>5</sup>/<sub>16</sub>" hole size) and properly torqued according to manufacturer-specified torque setting.

*Table 2 Required Cable (48VDC) Sizes*

Inverter/charger/converter	Cable Length: Battery to Inverter (one way)	Minimum Cable Size	Maximum battery Fuse Size
Freedom EX 4000	Less than 5 feet (1.5 meters)	No. 2 AWG	150 A DC, time delayed
<b>NOTE:</b> It is not recommended using a cable longer than 5 feet (1.5 meters) in each direction. North American cable sizes above are based on the US National Electrical Code Table 310.15 - 75 °C cables, assuming an ambient temperature of 30 °C cables.			

**IMPORTANT:** Using the correct cable size is critical to achieving the rated performance of the Freedom EX 4000 unit. When starting a heavy load the Freedom EX 4000 can draw current surges from the battery of up to 250A. If the DC wiring is too small the voltage drop from this surge will result in a voltage at the Freedom EX 4000 terminals that is too low for the Freedom EX 4000 to operate correctly. The Freedom EX 4000 may appear to operate correctly with smaller cables until a heavy load such as a microwave or refrigerator attempts to start - then the unit may work correctly sometimes and not work correctly other times.

## DC Disconnects and Over-Current Devices

The DC circuit from the battery to the Freedom EX 4000 must be equipped with a disconnect and over-current device. This usually consists of a circuit breaker, a "fused-disconnect", or a separate fuse and DC disconnect. **Do not confuse AC circuit breakers with DC circuit breakers.** They are not interchangeable. The rating of the fuse or breaker must be matched to the size of cables used in accordance with the applicable installation codes. The breaker or disconnect and fuse should be located as close as possible to the battery, in the positive cable. Applicable codes may limit how far the protection can be from the battery.

## Surge Arrester

In a marine installation, each system requires a separate method of protecting the DC circuits from a transient over-voltage, also called a spike or short duration electrical surge. This protection device is often referred to as a surge protection device (SPD) or transient voltage surge suppressor (TVSS). An SPD or TVSS must be mounted on the vessel's DC circuit breaker panel according to marine electrical codes or regulations.

## DC Cabling (12VDC)

The cable size is dependent on the maximum cable size the connector inside the unit is rated for, which is 6 AWG (16 mm<sup>2</sup>).

## 12VDC Load Panel

The DC load circuit from the Freedom EX 4000 must be equipped with a 12V DC fuse or circuit breaker through a 12VDC load distribution panel.

## Batteries

The Freedom EX 4000 uses 48-volt battery banks typically. Every Freedom EX 4000 system is recommended to have a lithium-ion (see Caution below) or deep-cycle lead-acid battery or group of batteries with a total capacity of 100 Ah or more which provides the DC current that the Freedom EX 4000 converts to AC.

### CAUTION

#### LITHIUM ION BATTERY TYPE HAZARD

Make sure to use a lithium ion battery pack that includes a certified Battery Management System (BMS) with built-in safety protocols including a pre-charge contactor (see NOTE below). Follow the instructions published by the battery manufacturer.

**Failure to follow these instructions can result in serious injury or equipment damage.**

**NOTE:** A pre-charge circuit is a featured built-in contactor by some battery manufacturers which regulates inrush current from the inverter's capacitors allowing a smooth transition into full power system operation.

### NOTICE

#### BATTERY DAMAGE

Do not mix battery types. The Freedom EX 4000 can only select one battery type setting for all batteries connected to its bank. All connected batteries should either be: *F<sub>LD</sub>* (Flooded or wet) or *GE<sub>L</sub>* (gel) or *AG<sub>M</sub>* (Absorbed glass mat) or *USE* (Custom) or *LFP* (lithium-ion).

**Failure to follow these instructions can result in equipment damage.**

## Step 2: Choosing a Location for the Unit

### ⚠ WARNING

#### FIRE AND EXPLOSION HAZARDS

- Do not install the Freedom EX 4000 in compartments containing batteries or flammable materials, or in locations that require ignition-protected equipment. This includes any space containing gasoline-powered machinery, fuel tanks, or joints, fittings, or other connections between components of the fuel system. This equipment contains components that tend to produce arcs or sparks.
- Do not install on or over combustible surfaces.
- Do not cover or obstruct the ventilation openings.
- Do not install the Freedom EX 4000 in a zero-clearance compartment. Overheating may result.

**Failure to follow these instructions can result in death, serious injury, or equipment damage.**

The Freedom EX 4000 should only be installed in locations that meet the following requirements:

- Dry.** Do not allow water or other fluids to drip or splash on the Freedom EX 4000. **Do not mount the Freedom EX 4000 in an area subject to splashing water or bilge water.**
- Cool.** Normal air temperature should be between  $-20^{\circ}\text{C}$  and  $40^{\circ}\text{C}$  ( $-4^{\circ}\text{F}$  and  $104^{\circ}\text{F}$ )—the cooler the better, for increased efficiency and product life extension.
- Ventilated.** Allow at least 12 cm (~5 inches) of clearance at the wiring access (AC and DC) end of the Freedom EX 4000 allowing air intake flow through the fans. Provide similar clearance at the opposite end where the air vent is located. The more clearance for ventilation around the unit, the better the performance. Do not allow the ventilation openings to become obstructed.
- Safe.** Do not install the Freedom EX 4000 in the same compartment as batteries or in any compartment capable of storing flammable liquids like gasoline.
- Close to the battery compartment and the AC source and load panels.** Avoid excessive cable lengths (which reduce input and output power due to wire resistance). Use the recommended cable lengths and sizes, especially between the battery banks and the Freedom EX 4000.
- Protected from battery acid and gases.** Never allow battery acid to drip on the Freedom EX 4000 or its wiring when reading specific gravity or filling the battery. Also do not mount the unit where it will be exposed to gases produced by the batteries. These gases are very corrosive, and prolonged exposure will damage the Freedom EX 4000.

## Step 3: Mounting the Unit

### ⚠ WARNING

#### HEAVY EQUIPMENT

Always use proper lifting techniques during handling and installation. A two-person lift is required to prevent personal injury.

**Failure to follow these instructions can result in death, serious injury, or equipment damage**

#### To mount the Freedom EX 4000:

- Remove the Freedom EX 4000 from its shipping container, verify that all components are present, and record relevant product information on "Information About Your System" in the Owner's Guide.
- Select an appropriate mounting location and orientation (see *Figure 3*). To meet regulatory requirements, for use in on-land applications, the Freedom EX 4000 must be mounted in one of the following orientations:
  - On a horizontal surface (ideal)
  - On a vertical surface such as a wall or rack

*Figure 3 Approved Mounting Orientations*

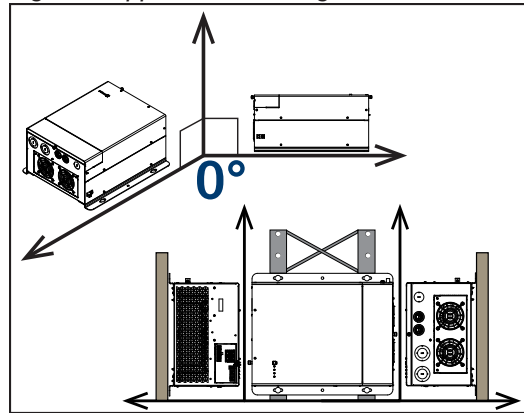

The following instructions are for mounting in on a vertical surface.

- Mark the desired number of mounting holes on the wall. Refer to the measurements of the mounting keyholes in *Product dimensions on page 45*
- Pilot-drill the mounting holes.
- Fasten the Freedom EX 4000 to the mounting surface. If you are mounting the unit on a wall or bulkhead, use #12 or #14 pan-head wood or sheet metal screws to secure it to the framing behind the wall or bulkhead. Alternatively, use nut inserts and  $\frac{1}{4}$ "-20 machine screws.

## Connecting the DC Equipment Ground

### **⚠ WARNING**

#### **ELECTRIC SHOCK HAZARD**

Never operate the Freedom EX 4000 without properly connecting the equipment ground. A shock and energy hazard could result from improper grounding.

**Failure to follow these instructions can result in death, serious injury, or equipment damage.**

The Freedom EX 4000 has a DC ground lug on the side of the unit as shown in *Connecting the DC Equipment Ground*. Follow the guidelines in *Connecting the DC Equipment Ground* to connect the inverter/charger/converter's chassis to the ground.

Figure 4 DC Panel Connections

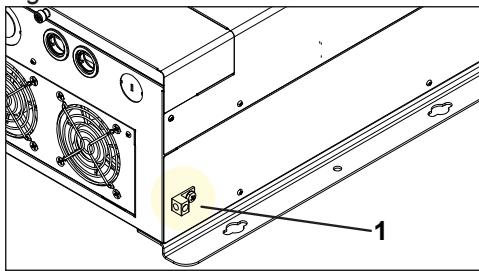

1	DC grounding lug
---	------------------

## Grounding Locations

You must connect the equipment DC ground lug to a grounding point—usually the vehicle's chassis or DC negative bus ground—using recommended copper wire size (if insulated then green insulation with or without one or more yellow stripes) or larger.

Make sure to tighten the bolt on the DC ground lug to a torque of 23 in-lb (2.6 N-m) of force. Apply an anti-corrosion compound to the copper wire prior to connecting to the DC ground lug.

For recommended equipment ground cable size, see below.

Table 3 Equipment DC ground cable size

Application	Minimum equipment ground cable size (Stranded copper cable is required)
Recreational Vehicle <sup>a</sup>	No. 8 AWG
Marine <sup>b</sup>	No. 3 AWG

**NOTE:** There are no restrictions on length for the equipment ground cable but try to make it as short as practical to a secure chassis connection. In general, the equipment ground cable size must not be smaller than one AWG size than the supply cable.

<sup>a</sup>Based on US National Electrical Code NFPA70, Article 551, par. 551-20c and ANSI/RVIA LV, § 2-5.1.

<sup>b</sup>Based on ABYC E-11 § 11.16 2

## Step 4: Connecting the AC Input Wires

### WARNING

#### ELECTRIC SHOCK AND FIRE HAZARDS

Make sure wiring is disconnected from all electrical sources before handling. All wiring must be done in accordance with local and national electrical wiring codes. Do not connect the output terminals of the Freedom EX 4000 to any incoming AC source.

**Failure to follow these instructions can result in death, serious injury, or equipment damage.**

### General AC Wiring Considerations

#### AC Wiring Connectors

Where applicable, connect AC wires with crimp-on splice connectors. The amount of insulation you strip off individual wires will be specified by the connector manufacturer and is different for different types of connectors.

#### AC and DC Wiring Separation

Do not mix AC and DC wiring in the same conduit or panel. Where DC and AC wires must cross, make sure they do so at 90° to one another. Consult applicable codes for details about DC and AC wiring in close proximity to each other.

#### AC Wiring and GFCIs

You can also connect the inverter to an existing AC installation and then plug loads into GFCI receptacles connected to that circuit.

AC wiring includes all the wires and connectors between the AC source and the Freedom EX 4000 and all wiring between the inverter/charger/converter, the AC panels, GFCI, and circuit breakers. The type and size of the wiring varies with the installation and load. For RV and marine applications, flexible multiple-strand copper wire is required.

AC wiring must be sized appropriately using conductors with insulation rated at least 75 °C to carry full load current on the input and output AC circuits in accordance with the electrical codes or regulations applicable to your installation. *Table 4* is based on the U.S. National Electrical Code and the Canadian Electrical Code, assuming two-conductor-plus-ground cable, using 75 °C wiring, at an ambient temperature of 30 °C. Other codes and regulations may be applicable to your installation.

*Table 4 Required AC wire size vs. required breaker rating*

	Required Breaker Size (amps)	Required Wire Size
Freedom EX 4000	50 A maximum per line	8 AWG <sup>3</sup> 10 AWG <sup>4</sup>

The AC input terminal is located inside the unit through the front panel's ½" trade-size hole (or ¾" trade-size knockout) and is labeled properly as **AC IN** or **AC INPUT**. Similarly, the AC output terminal is located inside the unit through the front panel's ½" trade-size hole (or ¾" trade-size knockout) and is labeled properly as **AC OUT** or **AC OUTPUT**. The unit comes with spring clamp-type terminals where individual wires can be attached securely.

#### Size of AC Output Wiring (35A single-phase)

Wire size must be coordinated with the current the wiring will carry. This current may be determined by the 33.3-amp maximum inverter current, or by the pass-through current, which is determined by the overcurrent protection provided ahead of the Freedom EX 4000.

Some conditions:

- If the input wiring is split-phase, the output wiring must be sized to coordinate with the breakers used on the input. Refer to your applicable installation codes.
- If the input wiring is dual-input and the output wiring is single-output, the following rules apply: If the input breaker on L1 is greater than 33.3 amps, the wire size must be coordinated for that amperage. If the input breaker on L1 is less than 33.3 amps, the wire size must be coordinated for 33.3 amps. The wire size must not be sized for anything lower than 33.3 amps.

<sup>3</sup> single-phase, 75 °C minimum rated

<sup>4</sup> split-phase, 75 °C minimum rated

- If both the input and the output wiring are dual-input, the output wiring for each line (L1 and L2) must be calculated separately, following these rules: If the input breaker on the specific line is greater than 33.3 amps, the wire size for that line and its neutral must be coordinated for that amperage. If the input breaker on the specific line is less than 33.3 amps, the wire size for that line and its neutral must be coordinated for 33.3 amps. The wire size must not be sized for anything lower than 33.3 amps.

**Size of Wiring Downstream of the AC Output Breaker (50A single-phase)**

The wire size must be coordinated with the current the wiring will carry. This current may be determined by the 33.3-amp maximum inverter current, or by the pass-through current, which is determined by the overcurrent protection provided ahead of the Freedom EX 4000.

<b>NOTICE</b>
<b>EQUIPMENT DAMAGE</b>
Make sure the wires are connected properly. The AC wiring terminal blocks are split into input and output sections.
<b>Failure to follow these instructions can result in equipment damage.</b>

When making the AC input and AC output connections, observe the correct color code for the appropriate AC wire, as described in *Table 5* below.

*Table 5 Color codes for typical AC wiring*

Color	AC Wire
Black/Red/Brown	Line
White/light blue	Neutral
Green, green/yellow, or bare copper	Ground (Earth)

<b>⚠ DANGER</b>
<b>REVERSE LINE/NEUTRAL DAMAGE</b>
Make sure the wires are connected properly. Improper connections (connecting a line conductor to a neutral conductor, for example) will cause a hazardous line to exist and may cause the Freedom EX 4000 to malfunction and may permanently damage the inverter/charger/converter. Damage caused by miswiring the line and neutral is not covered by your warranty.
<b>Failure to follow these instructions will result in death or serious injury.</b>

**Wiring Knockouts**

When installing wires to the AC terminals, the AC input and output holes are provided to accommodate 1/2" trade-size bushings (supplied) or optional strain relief devices. If larger cables and strain relief clamps are needed, remove the 3/4" trade-size knockout rings.

<b>NOTICE</b>
<b>EQUIPMENT DAMAGE</b>
Install optional AC knockout plugs over knockout holes when not used for wiring to prevent objects and other material from entering the unit.
<b>Failure to follow these instructions can result in equipment damage.</b>

## AC Input Connections

### To make a permanent connection to existing AC wiring:

1. Ensure AC and DC power sources are turned off.
2. Install the required circuit breaker in the AC distribution panel supplying AC power to the unit. In a marine installation, mount the required SPD or TVSS in the AC distribution panel as well, according to marine electrical codes or regulations.
3. Remove the wiring compartment cover by loosening the captive nut panel screw and lifting the cover up and out (Figure 5).

**NOTE:**

Use a screwdriver to loosen the captive nut panel screw.

Figure 5 Loosening the captive nut panel screw

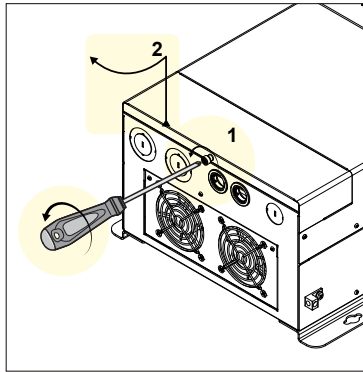

1	Captive nut panel screw
2	Wiring compartment cover

4. Strip 10 mm off the ends of each of the wires (tin the exposed copper wire with lead-free solder using a soldering iron) in the AC cable (3+1G cable).
5. Remove the knockout and install the supplied 3/4" bushing on the AC input hole. Alternatively, you can install a 3/4" strain-relief device instead of the bushing.
6. Route the wires through the bushing (or strain relief device).

Figure 6 Routing and connecting the AC input wires

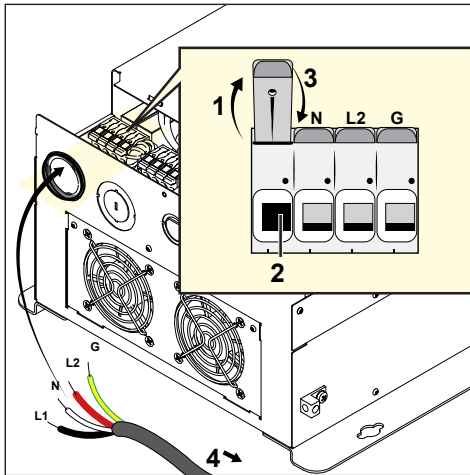

1	Lift the terminal lever (as shown in the previous figure).	4	Route to circuit breaker.
---	--	---	---------------------------

2	Insert the wire fully into the open slot.	<b>NOTE:</b> AC input hole - install a bushing (supplied) or a strain-relief device.
3	Lower the terminal lever to secure the wire in the slot.	

7. Locate the Neutral, Ground and Line terminals on the AC input terminal labeled as **L1**, **N**, **L2**, and **G** respectively.
8. Connect each AC wire into its corresponding terminal on the no-tool cage clamp terminal block.
9. Make sure that each AC wire is matched and connected to the Neutral (**N**), Ground (**G**), and Line (**L1** and **L2**) connections.
10. If a strain-relief device was installed, tighten the strain relief clamp to secure the wires.
11. Replace the wiring compartment cover onto the unit (using a #2 Phillips torque screwdriver - see WARNING), if you are not connecting other wires such as for the AC Output. Otherwise, keep the AC compartment open and proceed to the next step.

## **⚠ WARNING**

### ELECTRICAL SHOCK HAZARD

Use a torque screwdriver to tighten the captive nut panel screw to 5 in-lb (0.56 N-m) torque of force to ensure a proper ground connection and a required tool access to the wiring compartment.

**Failure to follow these instructions can result in death, serious injury, or equipment damage.**

12. Connect the other end of the wires to the circuit breaker in the AC distribution panel supplying AC power to the unit. For possible wiring configurations into the vehicle's (or vessel's) input AC distribution panel, see the *various figures starting on page 23*.

## Step 5: Connecting AC Output to an Existing AC Circuit

### ⚠ WARNING

#### ELECTRIC SHOCK AND FIRE HAZARDS

- Make sure wiring is disconnected from all electrical sources before handling. All wiring must be done in accordance with local and national electrical wiring codes.
- A manufacturer-tested and approved GFCI must be connected to the Freedom EX 4000 AC output, and GFCI protection must be provided on every branch circuit feeding a receptacle connected to the AC hard wired installation. Other types may fail to operate properly when connected to the Freedom EX 4000. See *Ground Fault Circuit Interrupters (GFCIs)* on page 14.

Failure to follow these instructions can result in death, serious injury, or equipment damage.

### NOTICE

#### EQUIPMENT DAMAGE

- Do not connect any AC source (such as a generator or utility power) to the **AC output wiring** of the Freedom EX 4000.
- The Freedom EX 4000 will not operate if its output is connected to AC voltage from a source, and potentially hazardous or damaging conditions may occur. These conditions can occur even if the inverter/charger/converter is off.

Failure to follow these instructions can result in equipment damage.

Do not connect the Freedom EX 4000 to an AC branch circuit that has high-power consumption loads that exceed its output wattage rating.

The Freedom EX 4000 will not operate electric heaters, air conditioners, stoves, and other electrical appliances that consume more than its rated output wattage.

## AC Output Connections

Figure 7 Routing and connecting the AC output wires

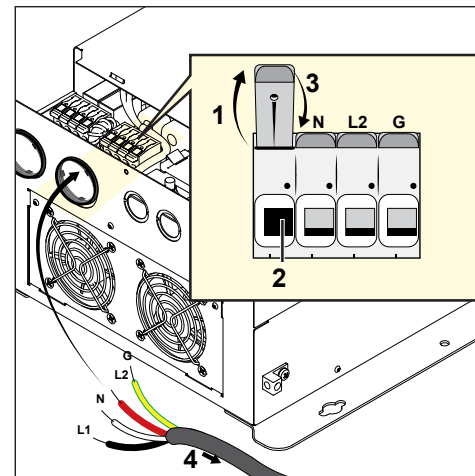

1	Lift the terminal lever.	4	Route to circuit breaker
2	Insert the wire fully into the open slot.	<b>NOTE:</b> AC Output hole - install a bushing (supplied) or a strain-relief device.	
3	Lower the terminal lever to secure the wire in the slot.		

#### To make a permanent connection to existing AC wiring:

- Ensure AC and DC power sources are turned off, if not already done from *AC Input Connections* on page 20.
- Install the required circuit breaker in the inverter/charger/converter distribution panel receiving AC power from the inverter/charger/converter.
- Remove the wiring compartment cover, if not already done from *AC Output Connections* on page 21.

#### NOTE:

Use a screwdriver to loosen the captive nut panel screw.

- Strip 10 mm off the ends of each of the wires (tin the exposed copper wire with lead-free solder using a soldering iron) in the AC cable (3+1G cable).
- Remove the knockout and install the supplied  $\frac{3}{4}$ " bushing on the AC input hole. Alternatively, you can install a  $\frac{3}{4}$ " strain-relief device instead of the bushing.
- Route the wires through the bushing (or strain relief device).
- Locate the Neutral, Ground and Line terminals on the AC input terminal labeled as **L1**, **N**, **L2**, and **G** respectively.
- Connect each AC wire into its corresponding terminal on the no-tool cage clamp terminal block.
- Make sure that each AC wire is matched and connected to the Neutral (**N**), Ground (**G**), and Line (**L1** and **L2**) connections.
- If a strain-relief device was installed, tighten the strain relief clamp to secure the wires.
- Replace the wiring compartment cover (using a #2 Phillips torque screwdriver - see WARNING), if you are finished with connecting all the AC wires in the unit.

**! WARNING**

**ELECTRICAL SHOCK HAZARD**

Use a torque screwdriver to tighten the captive nut panel screw to 5 in-lb (0.56 N-m) torque of force to ensure a proper ground connection and a required tool access to the wiring compartment.

**Failure to follow these instructions can result in death, serious injury, or equipment damage.**

12. Connect the other end of the wires to a circuit breaker in AC distribution panel providing AC power to the loads. For possible wiring configurations into the vehicle's (or vessel's) output AC distribution panel, see the *following figures starting on page 23*.

Figure 8 50 A Service to 50 A RV Electrical System

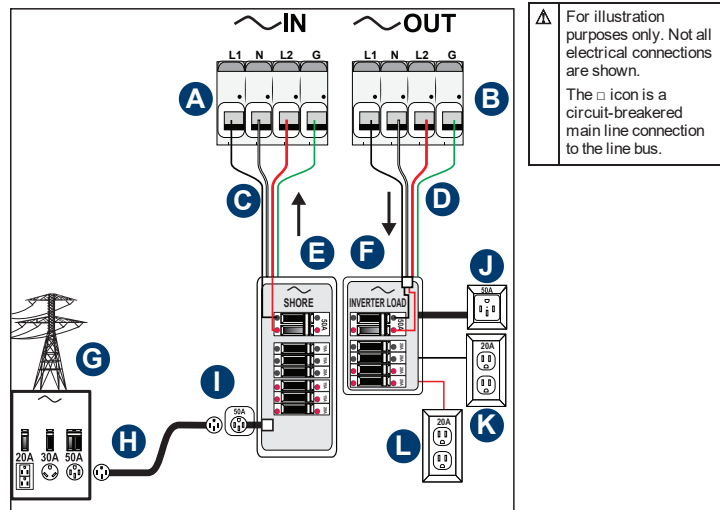

A	AC Input terminals	E	Vehicle's AC Shore Distribution Panel	I	50A RV/Vessel Inlet Receptacle
B	AC Output terminals	F	Vehicle's AC Inverter Distribution Panel	J	50A AC Load (split 120/240 VAC in, passthrough mode only). No power in inverter mode for 240 VAC
C	AC Input wires L1 N L2 G	G	Power Distribution Panel with 20A, 30A, and 50A standard outlets	K	20A AC Load (120 VAC) on L1 (inverter and passthrough modes)
D	AC Output wires L1 N L2 G	H	RV 50A Shore Power Extension Cord	L	20A AC Load (120 VAC) on L2 (inverter and passthrough modes)
⚠ Shore Power Distribution Panel outlets vary in different locations.					

Figure 9 30A Service to 50A RV Electrical System

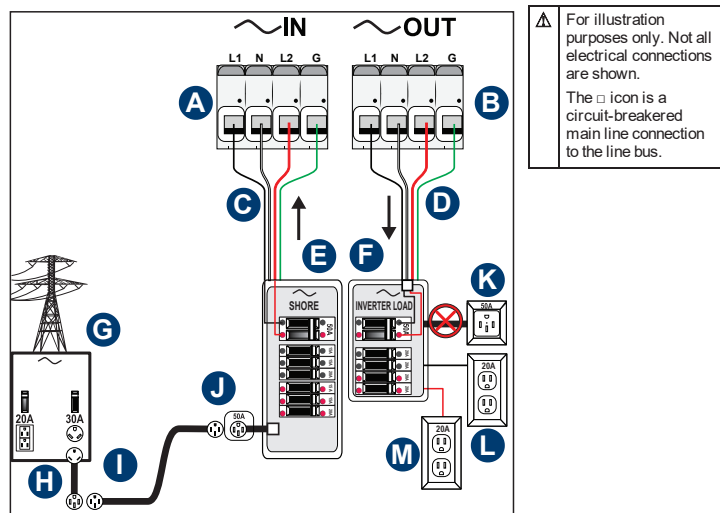

A	AC Input terminals	E	Vehicle's AC Shore Distribution Panel	I	RV 50A Shore Power Extension Cord
B	AC Output terminals	F	Vehicle's AC Inverter Distribution Panel	J	50A RV/Vessel Inlet Receptacle
C	AC Input wires L1 N L2 G	G	Shore Power Distribution Panel with 20A and 30A standard outlets	K	50A AC Load (single-phase 120 VAC). No power in inverter and passthrough modes for 240 VAC
D	AC Output wires L1 N L2 G	H	Dog Bone RV/Electrical Adapter 50A Female to 30A Male	L	20A AC Load (120 VAC) on L1 (inverter and passthrough modes)
⚠ Shore Power Distribution Panel outlets vary in different locations.					
				M	20A AC Load (120 VAC) on L2 (inverter and passthrough modes)

Figure 10 30A Service to 30A RV Electrical System

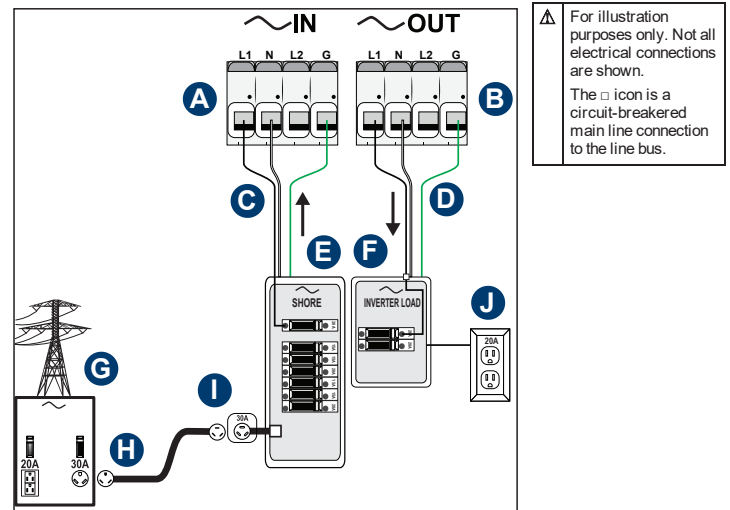

A	AC Input terminals	E	Vehicle's AC Shore Distribution Panel	I	30A RV/Vessel Inlet Receptacle
B	AC Output terminals	F	Vehicle's AC Inverter Distribution Panel	J	20A AC Load (120 VAC)
C	AC Input wires L1 N G	G	Shore Power Distribution Panel with 20A and 30A standard outlets	⚠ Shore Power Distribution Panel outlets vary in different locations.	
D	AC Output wires L1 N G	H	RV 30A Shore Power Extension Cord		

For information on stacking two Freedom EX 4000 units in series to form a split-phase 120/240 VAC inverter power system in Battery mode, see *Series Stacking on page 24*. For information on stacking two Freedom EX 4000 units in parallel to double inverting and charging capacity in Battery mode, see *Parallel Stacking on page 24*.

## Stacking Features

The Freedom EX 4000 supports series and parallel stacking configurations. This gives the system engineer and/or installer more options to work with when tailoring a system to meet load demands that require higher surge capacity and/or 8000W continuous power rating.

**IMPORTANT:**

Contact Xantrex prior to stacking two Freedom EX 4000 units together. Stacking configuration via USB is a required step to enable stacking.

### Series Stacking

The Freedom EX 4000 supports a series stacking configuration. In this configuration, two Freedom EX 4000 units may be stacked to form a split-phase during Battery mode 120/240VAC, 60 Hz, 33.3A, 8000W system required for high surge appliances such as ranges, dryers, and air conditioners. In Shore mode, charging capacity is doubled. See *Series Stacking on page 25*.

### Parallel Stacking

In parallel stacking mode, two Freedom EX 4000 inverterchargers can be stacked to provide a combined 120VAC, 60Hz, 66.6A, 8000W output rating during Battery mode. In Shore mode, charging capacity is doubled. See *Parallel Stacking on page 29*.

**IMPORTANT:** Parallel stacking configuration is available only via USB. Call a Xantrex authorized dealer for information.

### Series Stacking

A series stacking configuration allows two inverters to be configured to produce 120 and 240 VAC, also known as, a single-phase three-wire configuration. For example, a Freedom EX 4000 can be installed as **L1** while another Freedom EX 4000 operates as **L2**. However, it is important to remember that for series stacking configuration, only **AC IN L1 | AC OUT L1** terminals should be used and that the **AC IN L2 | AC OUT L2** terminals must have no connections at all. If **L2** is connected to any incoming or outgoing AC line, the inverter/charger may suffer internal damage not covered by warranty.

## NOTICE

### GENERAL PRECAUTIONS

- Contact Xantrex prior to stacking two Freedom EX 4000 units together. Stacking configuration via USB is a required step to enable stacking.
- Install stacked Freedom EX 4000s in close proximity to each other.
- Connect RJ45 CAT5e/6 straight-through network cables to each inverter's Sync port as well as the RV-C ports shown in *Figure 13* below.
- Do not connect any wires to the **AC IN L2 | AC OUT L2** terminals on both units at all when stacking.
- Each inverter must be enabled and turned on individually before AC power becomes available.

**Failure to follow these instructions can result in equipment damage and may void the warranty.**

Figure 11 Series Stacking Using Two Freedom EX 4000s

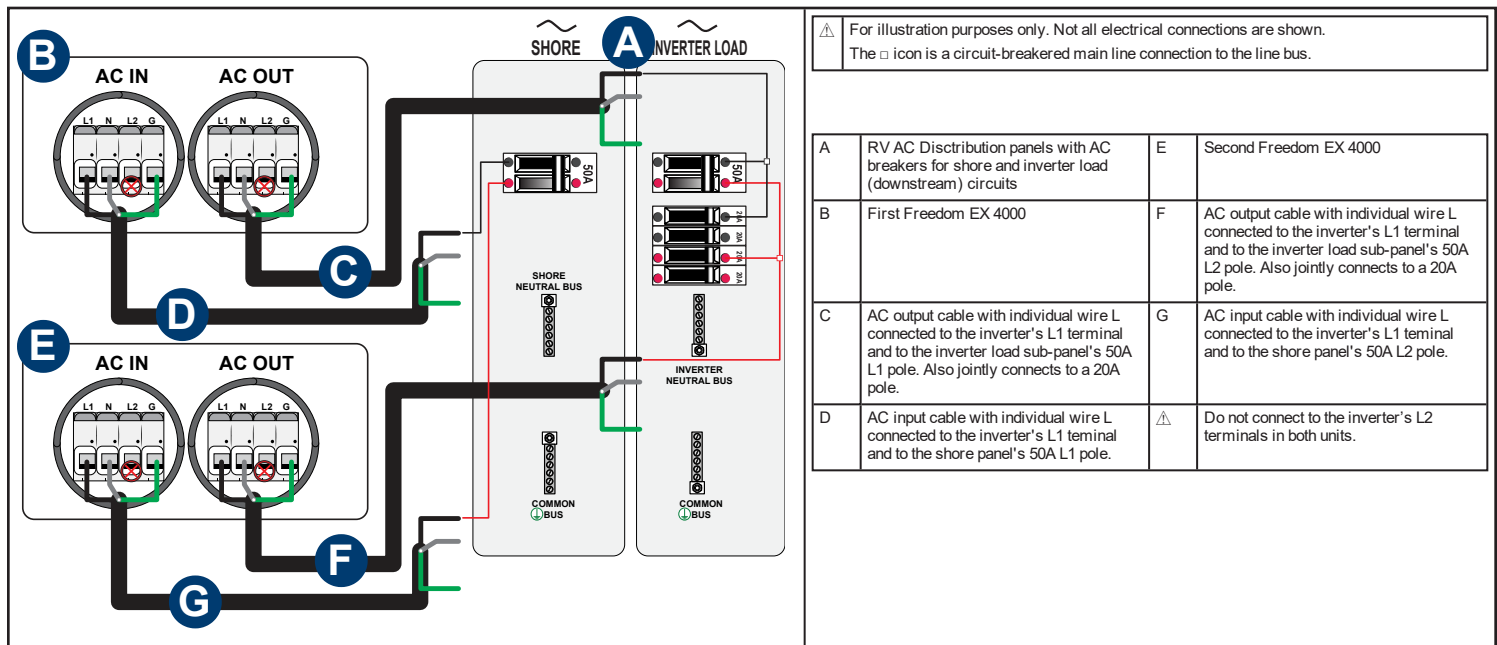

## NOTICE

### EQUIPMENT DAMAGE

Do not connect any wires to the **AC IN L2 | AC OUT L2** terminals on both units at all when series stacking.

**Failure to follow these instructions can result in equipment damage and may void the warranty.**

**Neutral-to-Ground Bonding**

Figure 12 N-G screw

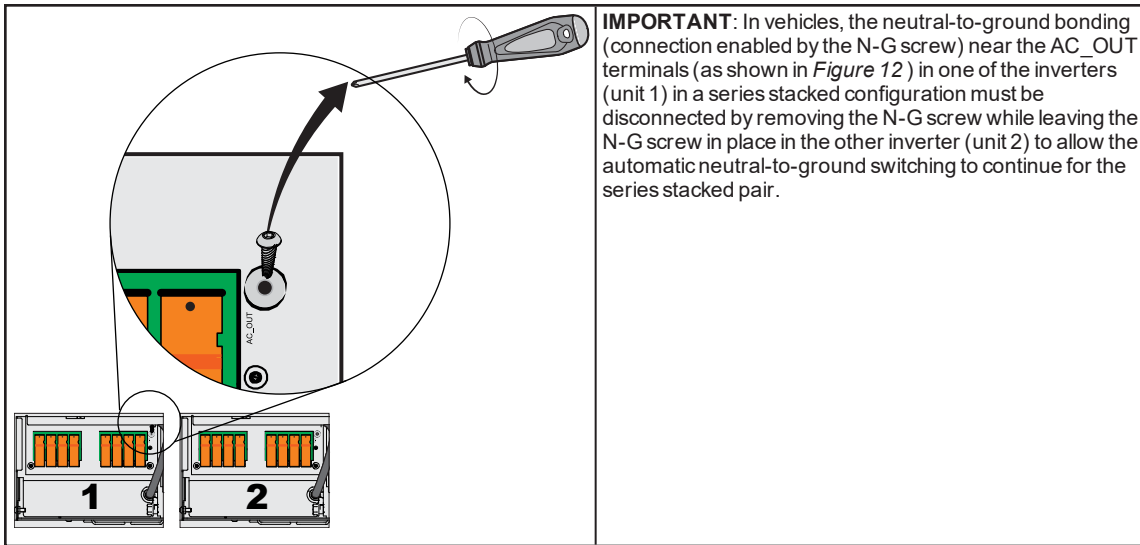

**RJ45 CAT5e/6 network cables**

For series stacking (120 and 240 volts), connect an RJ45 CAT5e/6 network cable between the two **Sync** ports as well as the two **RV-C** ports.

Figure 13 Series Stacking Using Two Freedom EX 4000s

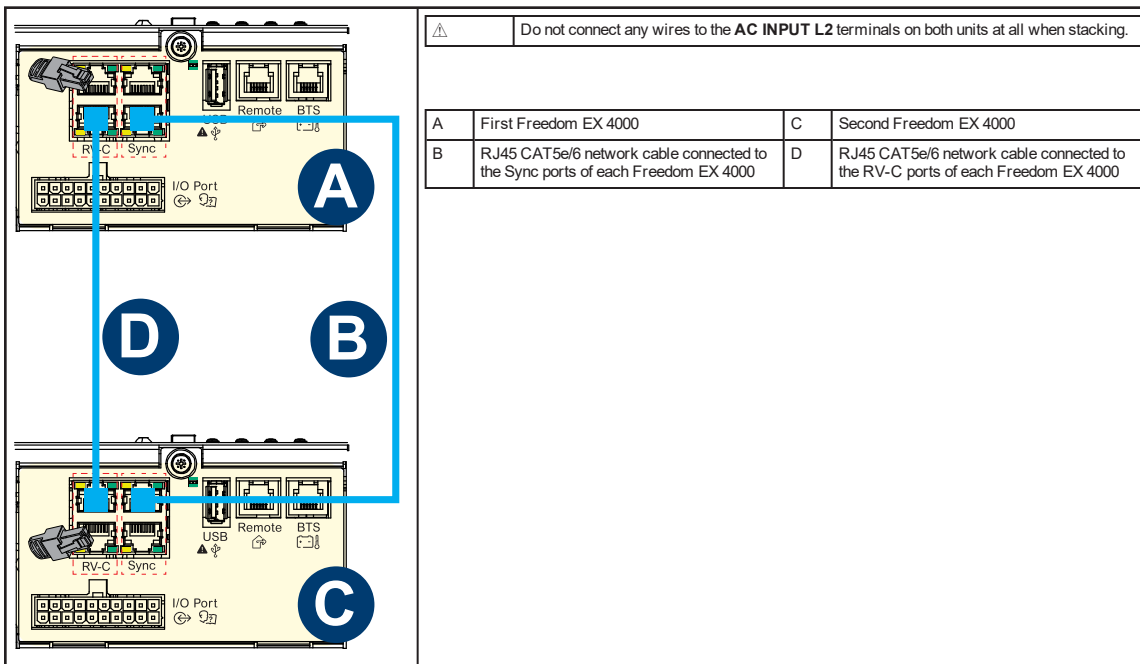

**Series Stacking Operation**

The pair of series stacked inverters is designed to accept input power from a single-phase, three-wire 120/240-VAC system with 120 volts to each inverter. The input line (**INPUT L1**) terminal of each inverter accepts one leg of 120 volts each and the input neutral (**INPUT N**) terminals of both inverters are tied together and connected to the power source neutral leg. The protective ground conductor of each cable is connected at both of the inverter input ground (**INPUT G**) AC terminal connectors.

Any AC load being powered while AC input is present to the inverters will be in addition to the power being drawn for charging the batteries. Each unit in the stack can provide a full pass-through current of 30 amps for 120-volt systems.

When AC input power is lost, both units in the stack switch from charger to inverter mode. Once this switch is made, 120 volts AC is available from each individual inverter or 240 volts AC is available across the output line (**OUTPUT L1**) terminals of the stacked pair. This kind of synchronization is possible when the Sync cable is attached to the Sync ports on the paired units.

Stacked Freedom EX 4000 inverters will typically support about twice the surge power of one standalone unit. For example, a Freedom EX 4000 stacked pair will support a surge of about 16 000 watts.

### Neutral Wiring for Series Stacked Inverters

In a stacked pair configuration, connect the two AC input neutrals together at the main distribution panel and the two AC output neutrals at an isolated neutral location in the inverter AC distribution panel.

## NOTICE

### GENERAL PRECAUTIONS

- Contact Xantrex prior to stacking two Freedom EX 4000 units together. Stacking configuration via USB is a required step to enable stacking.
- Install stacked Freedom EX 4000s in close proximity to each other.
- Connect an RJ45 CAT5e/6 network cable to each inverter's Sync port as well as the RV-C ports.
- Do not connect any wires to the **AC IN L2 | AC OUT L2** terminals on both units at all when stacking.
- Each inverter must be enabled and turned on individually before AC power becomes available.

**Failure to follow these instructions can result in equipment damage and may void the warranty.**

Figure 14 Neutral and Ground Wiring for Stacking

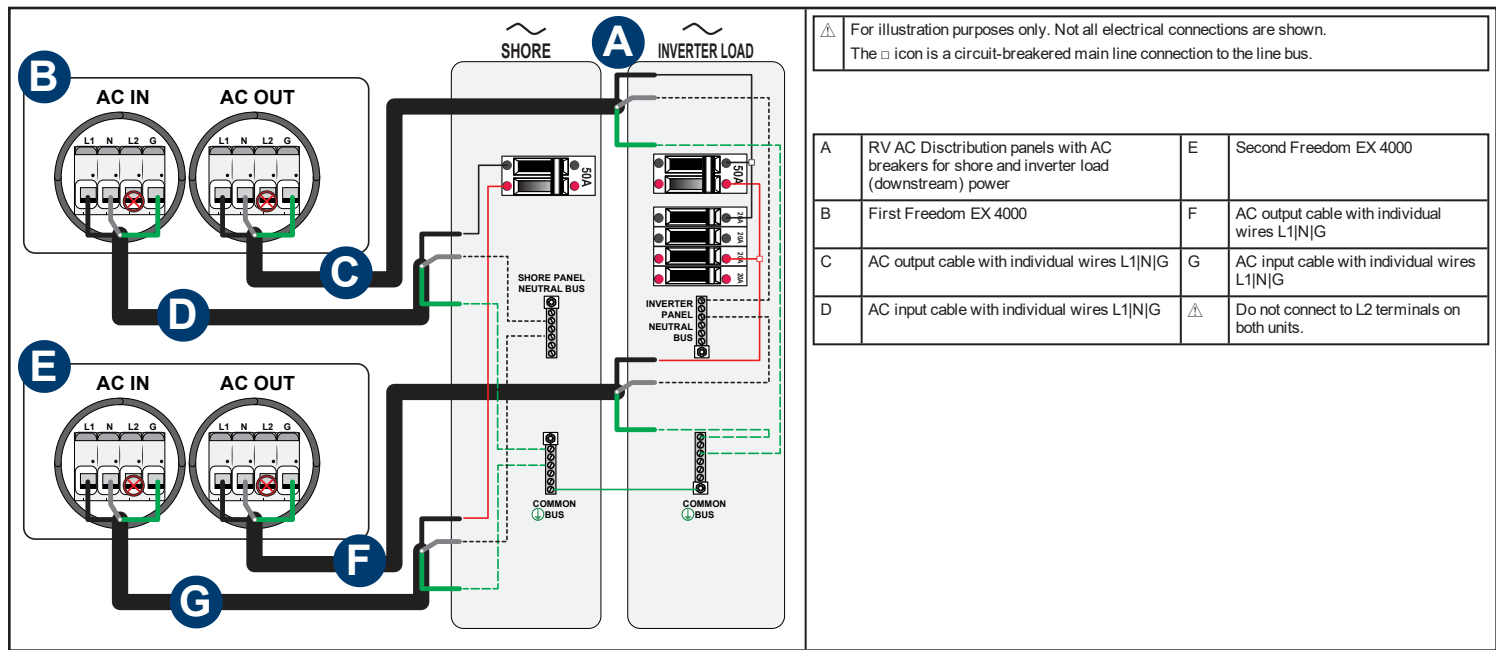

## Parallel Stacking

A parallel stacking configuration allows the inverter and charger capacity of a system to be doubled. Parallel-stacked inverter/chargers can operate from different battery banks, meaning each unit is connected to its own battery bank. However, it is highly recommended to only use a single battery bank similar to series stacking. See *on page 35*.

### NOTICE

#### GENERAL PRECAUTIONS

- Contact Xantrex prior to stacking two Freedom EX 4000 units together. Stacking configuration via USB is a required step to enable stacking.
- Install stacked Freedom EX 4000s in close proximity to each other.
- Connect RJ45 CAT5e/6 straight-through network cables to each inverter's Sync port as well as the RV-C ports shown in *Figure 15* below.
- Do not connect any wires to the **AC IN L2 | AC OUT L2** terminals on both units at all when stacking.
- Each inverter must be enabled and turned on individually before AC power becomes available.

**Failure to follow these instructions can result in equipment damage and may void the warranty.**

Figure 15 RJ45 CAT5e/6 network cable for parallel stacking

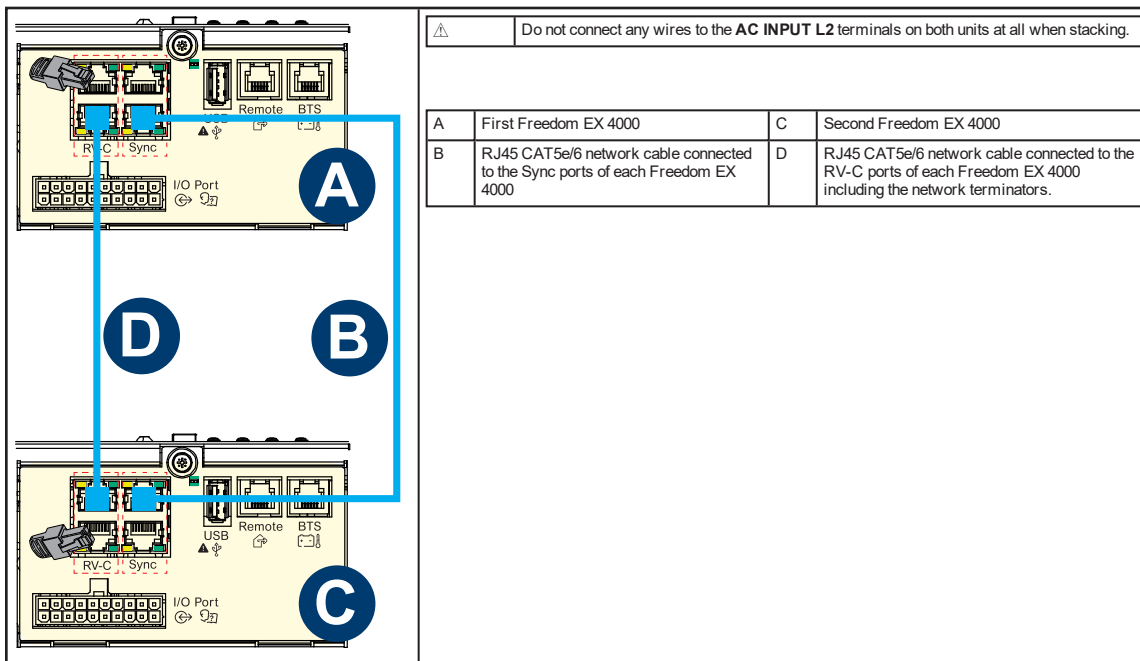

#### Line and Neutral Wiring for Parallel Stacked Inverters

**AC IN L2** terminals on both units must not be connected at all. Also for parallel stacking configuration, only **AC IN L1 | AC OUT L1** terminals should be used and that the **AC IN L2 | AC OUT L2** terminals must have no connections at all. If **L2** is connected to any incoming or outgoing AC line, the inverter/charger may suffer internal damage not covered by warranty.

In a stacked pair configuration, connect the two AC input neutrals together at the main distribution panel (SOURCE) and the two AC output neutrals at an isolated neutral location in the inverter AC distribution sub-panel (INVERTER LOAD).

Figure 16 Parallel Stacking Using Two Freedom EX 4000s

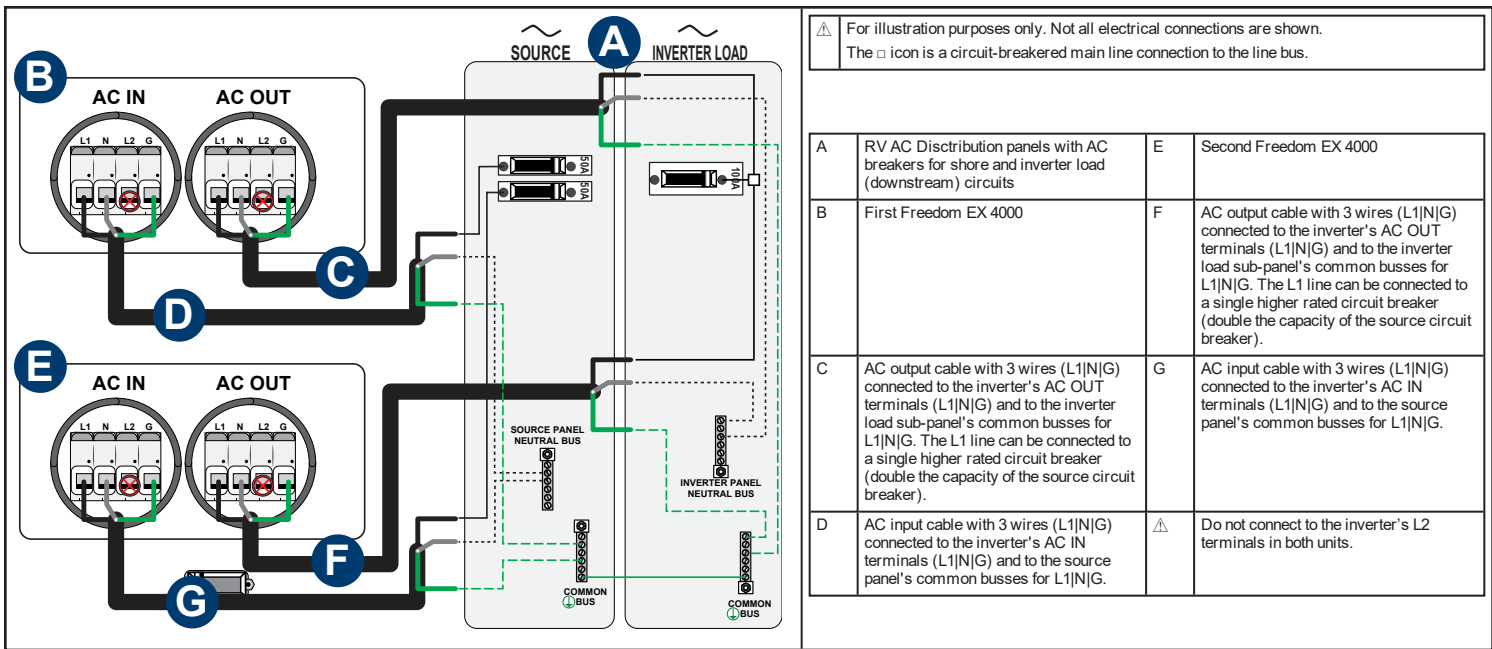

**Parallel Stacking Operation**

When two inverter/chargers are stacked for parallel operation, Search Mode must be enabled. For information on Search Mode setting, see the Freedom EX 4000 Owner's Guide (document number: 975-0999-01-01).

## Step 6: Connecting the DC Cables

### NOTICE

#### REVERSE POLARITY

- Check cable polarity at both the battery and the Freedom EX 4000 before making the final DC connection. Positive must be connected to positive; negative must be connected to negative.
- Reversing the positive and negative battery cables will blow a fuse in the Freedom EX 4000 and void your warranty.

**Failure to follow these instructions can result in equipment damage.**

### WARNING

#### FIRE HAZARD

Use only stranded, copper wire rated minimum 75 °C (105 °C for marine installations). Make sure all DC connections are tight to a torque of 71–80 in-lb (8–9 Nm) of force. Loose connections will overheat.

**Failure to follow these instructions can result in death, serious injury, or equipment damage.**

Follow the procedure given below to connect the battery leads to the terminals on the DC end. The cables should be as short as possible and large enough to handle the required current, in accordance with the electrical codes or regulations applicable to your installation. *Table 1* specifies the minimum DC cable size and maximum fuse size for the Freedom EX 4000.

If at all possible, minimize routing your DC cables through an electrical distribution panel, battery isolator, or other device that will cause additional voltage drops which can degrade the inverter/charger/converter's ability to operate the loads.

*Figure 17 48V DC connections*

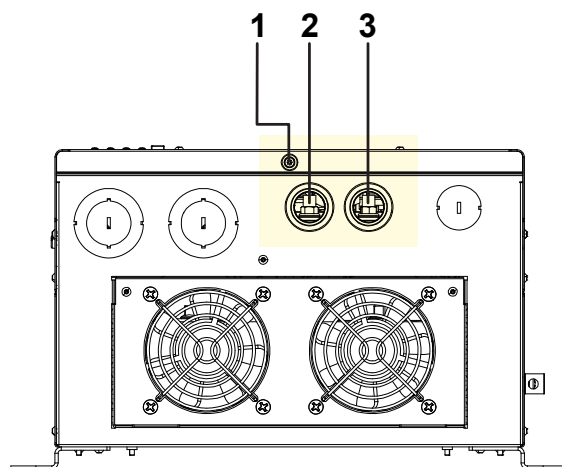

1	captive nut panel screw
2	negative (-)
3	positive (+)

#### To make the 48V DC connections:

1. Make sure the inverter/charger/converter is off and no AC or DC is connected to the unit.
2. Remove the wiring compartment cover by loosening the captive nut panel screw.

#### NOTE:

Use a screwdriver to loosen the captive nut panel screw.

3. Loosen the DC terminal nuts from the terminal bolts and set them aside for later.
4. Strip  $\frac{1}{2}$ " (13 mm) to  $\frac{3}{4}$ " (19 mm) insulation from one end of each cable. The amount stripped off will depend on the terminals chosen.
5. Attach the connectors that will secure the cables to the battery, to the disconnect/battery selector switch, and the fuse block. The connectors you use must create a permanent, low-resistance connection. It is recommended to use approved and certified cable ring lugs. Use the tool recommended by the terminal manufacturer. Make sure no stray wires protrude from the lug or terminal.
 

**NOTE:** You may find it more convenient to have the cable lugs attached by the company that sells you the cable and/or connectors.
6. Strip  $\frac{1}{2}$ " (13 mm) to  $\frac{3}{4}$ " (19 mm) of insulation from each cable end that will be connected to the inverter/charger/converter. The amount stripped off will depend on the terminals chosen.
7. Attach the cable ring lug that will join the cable to the inverter/charger/converter DC terminal. Cover the lug stem with heat shrink insulation (see *Step 6: Connecting the DC Cables*) to ensure that the lug does not touch the enclosure.
8. Install a fuse and fuse holder in the cable that will be used for the positive side of the DC circuit. The fuse must:
  - a. be as close to the battery positive terminal as possible
  - b. be rated for 48V DC circuits
  - c. have an Ampere Interrupting Capacity (AIC) that exceeds the short-circuit current available from the battery (that is, Class T fuse)
9. To prevent sparking when making the connection, ensure the disconnect/battery selector switch is off.
10. Route the positive cable through the right side strain relief clamp and attach the cable lug on the positive cable to the positive 48V DC terminal on the inverter/charger/converter.
11. Fasten the DC terminal nut (set aside earlier) to the terminal bolt. Tighten the nut to a torque of 8–9 N-m (71–80 in-lb) of force. Do not overtighten. Make the connection snug enough so the cable lug does not move around on the DC terminal. Center it through the DC knockout hole and do not let it touch the edge. See *Step 6: Connecting the DC Cables on page 31*.

**⚠ WARNING**

**ELECTRICAL SHOCK HAZARD**

- Tighten the nuts on the DC terminals properly. Loose connections cause excessive voltage drop and may cause overheated wires and melted insulation.
- Do not over-tighten the nut on the DC input terminals because damage to the DC input terminals may result. Use a torque screwdriver to tighten the nut to a maximum torque of 80 in-lb (9 N-m) of force.

**Failure to follow these instructions can result in death, serious injury, or equipment damage.**

**NOTICE**

**REVERSE POLARITY**

- Check cable polarity at both the battery and the Freedom EX 4000 before making the final DC connection. Positive must be connected to positive; negative must be connected to negative.
- Reversing the positive and negative battery cables will blow a fuse in the Freedom EX 4000 and void your warranty.

**Failure to follow these instructions can result in equipment damage.**

Figure 18 48V DC Cable Connections

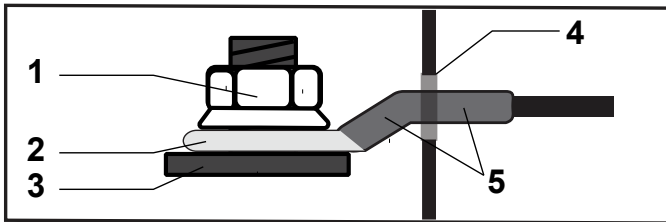

1	serrated 48V DC terminal bolt flange nut
2	cable ring lug
3	48V DC terminal
4	DC knockout hole
5	DC cable with heat shrink insulation covering the lug stem

**NOTE:** The DC cable lug stem must be fully insulated with the heat shrink.

12. Before proceeding, double check that the cable you have just installed connects the positive DC terminal of the inverter/charger/converter to the disconnect/battery selector switch, fuse holder, and that the other end of the fuse holder is connected to the positive terminal of the battery.

**⚠ WARNING**

**FIRE HAZARD**

Do not complete the next step if flammable fumes are present. Explosion or fire may result if the disconnect/battery selector switch is not in the off position. Thoroughly ventilate the battery compartment before making this connection.

**Failure to follow these instructions can result in death, serious injury, or equipment damage.**

13. Route the negative cable through the left side strain relief clamp and connect the cable from the negative post of the battery to the negative 48V DC terminal of the inverter/charger/converter.
14. Fasten the DC terminal nut (set aside earlier) to the terminal bolt. Tighten the nut to a torque of 8–9 N-m (71–80 in-lb ) of force. Do not overtighten. Make the connection snug enough so the cable lug does not move around on the DC terminal. Center it through the DC knockout hole and do not let it touch the edge.
15. If applicable, connect the DC output cables. See *12V DC Output Cables on page 33*.
16. Replace the wiring compartment cover by tightening the captive nut panel screw. See the following electrical shock hazard warning.

**⚠ WARNING**

**ELECTRICAL SHOCK HAZARD**

Use a torque screwdriver to tighten the captive nut panel screw to 5 in-lb (0.56 N-m) torque of force to ensure a proper ground connection and a required tool access to the wiring compartment.

**Failure to follow these instructions can result in death, serious injury, or equipment damage.**

## 12V DC Output Cables

### ⚠ WARNING

#### FIRE HAZARD

Use only stranded, solder-tinned, copper wire rated minimum 75 °C (105 °C for marine installations). Tighten the DC screw terminals to a torque of 27.5 in-lb (3.1 Nm) of force. Loose connections overheat.

**Failure to follow these instructions can result in death, serious injury, or equipment damage.**

### NOTICE

#### EQUIPMENT DAMAGE

- Do not connect another battery (for the purpose of charging it) including supercapacitors to the 12VDC output terminal.
- Do not stack or parallel with other 12VDC output terminals. Call Xantrex customer support for options.
- When connecting to a DC load panel or DC bus, install a DC fuse rated at 80A fast blow ahead of the DC load panel or DC bus.
- In a marine installation, mount the required SPD or TVSS in the DC load panel of the vessel in lieu of the DC fuse, according to marine electrical codes or regulations..

**Failure to follow these instructions can result in equipment damage.**

Figure 19 12V DC Output

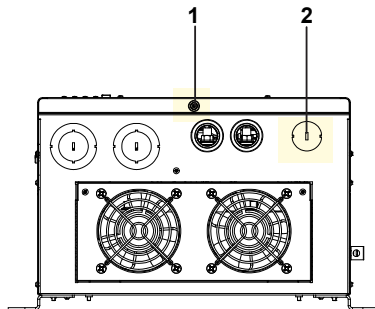

1	captive nut panel screw
2	single opening to <b>two DC output terminals</b> to be used for routing (-) negative and (+) positive DC cables

Figure 20 12V DC Output Terminal Block Connections

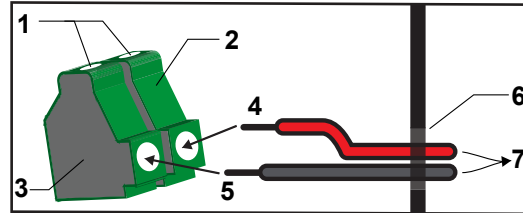

1	DC terminal screws (M6)
2	12V DC terminal block pos(+) pole
3	12V DC terminal block neg(-) pole
4	pos(+) DC cable, 6 AWG (16 mm <sup>2</sup> ), rated 75 °C (105 °C for marine installations)
5	neg(-) DC cable, 6 AWG (16 mm <sup>2</sup> ), rated 75 °C (105 °C for marine installations)
6	12V DC knockout hole with bushing (or strain-relief)
7	To the 12V DC load panel

### ⚠ WARNING

#### ELECTRICAL SHOCK HAZARD

Use a torque screwdriver to tighten the captive nut panel screw to 5 in-lb (0.56 N-m) torque of force to ensure a proper ground connection and a required tool access to the wiring compartment.

**Failure to follow these instructions can result in death, serious injury, or equipment damage.**

#### To make the 12V DC output connections:

- Remove the knockout and install a compatible 1/2" bushing on the DC output hole. Alternatively, you can install a 1/2" strain-relief device instead of a bushing.
- Loosen the DC terminal screws (see Figure 20).
- Strip 1/2" (13 mm) to 3/4" (19 mm) insulation from one end of the pos(+) DC cable and solder-tin the tip of the stripped cable.
- Route the positive cable through the bushing (or strain relief clamp) and attach the pos(+) DC cable to the 12V DC terminal block's pos(+) pole inside the inverter/charger/converter.
- Fasten the DC terminal screw. Tighten the screw to a torque of 27.5 in-lb (3.1 N-m) of force. Do not overtighten.

### ⚠ WARNING

#### ELECTRICAL SHOCK HAZARD

- Tighten the connections on the DC terminals properly. Loose connections cause excessive voltage drop and may cause overheated wires and melted insulation.
- Do not over-tighten the screw on the DC output terminals because damage to the DC output terminals may result. Use a torque screwdriver to tighten the nut to a torque of 27.5 in-lb (3.1 Nm) of force.

**Failure to follow these instructions can result in death, serious injury, or equipment damage.**

- Strip 1/2" (13 mm) to 3/4" (19 mm) insulation from one end of the neg(-) DC cable and solder-tin the tip of the stripped cable.

7. Route the negative cable through the bushing (or strain relief clamp) and attach the neg(-) DC cable to the 12V DC terminal block's neg(-) pole inside the inverter/charger/converter.
8. Fasten the DC terminal screw. Tighten the screw to a torque of 27.5 in-lb (3.1 N-m) of force. Do not overtighten.

### **NOTICE**

#### **REVERSE POLARITY**

- Check cable polarity at both the DC load panel and the Freedom EX 4000 before making the final DC connection. Positive must be connected to positive; negative must be connected to negative.
- Reversing the positive and negative DC cables will blow a fuse in the DC load panel.

**Failure to follow these instructions can result in equipment damage.**

9. Extend and connect the DC cables to the DC load panel inside the vehicle.
10. Replace the wiring compartment cover onto the unit (using a #2 Phillips torque screwdriver - see WARNING) and tighten the captive nut panel screw to secure the cover in place .

## DC Connections for Stacked Inverters

### Dual Inverter Single Battery Bank

In this configuration during Shore mode, the charging current is doubled to minimize charging time. Use individual overcurrent devices between the battery positive and each inverter. Keep cable lengths to the two inverter/chargers the same in order to balance cable losses. If not, the battery cable difference in length between the two inverter/chargers should not exceed 12 inches (30.48 cm).

### NOTICE

#### GENERAL PRECAUTIONS

- Contact Xantrex prior to stacking two Freedom EX 4000 units together. Stacking configuration via USB is a required step to enable stacking.
- Install stacked Freedom EX 4000s in close proximity to each other.
- Connect the inverter's battery negative terminals together. Install a 2-pole battery breaker near the battery positive terminals.
- Each inverter must be enabled and turned on individually before AC power becomes available.
- If parallel stacking Freedom EX 4000s to increase charging capacity, be sure to consult your battery manufacturer and battery specifications to avoid damaging the battery due to overcharging.

**Failure to follow these instructions can result in equipment damage.**

Connect the stacked system as follows:

1. Connect each negative terminal to the battery.
2. Connect a Grounding wire to the common negative.
3. Connect each positive terminal of the inverter to the battery through a single DC disconnect (for example, a 2-pole battery breaker) as shown below. Do not tie the positives together between inverters.
4. Connect the Ground bonding wire from each inverter to the same location on the vehicle chassis. Use that same length and gauge wire for both inverter/chargers.
5. Connect the battery temperature sensors (BTS), if needed.
6. Make sure the DC disconnect device is open to prevent energizing the inverter/charger.

Figure 21 Connecting Battery Cables and DC Ground Wires

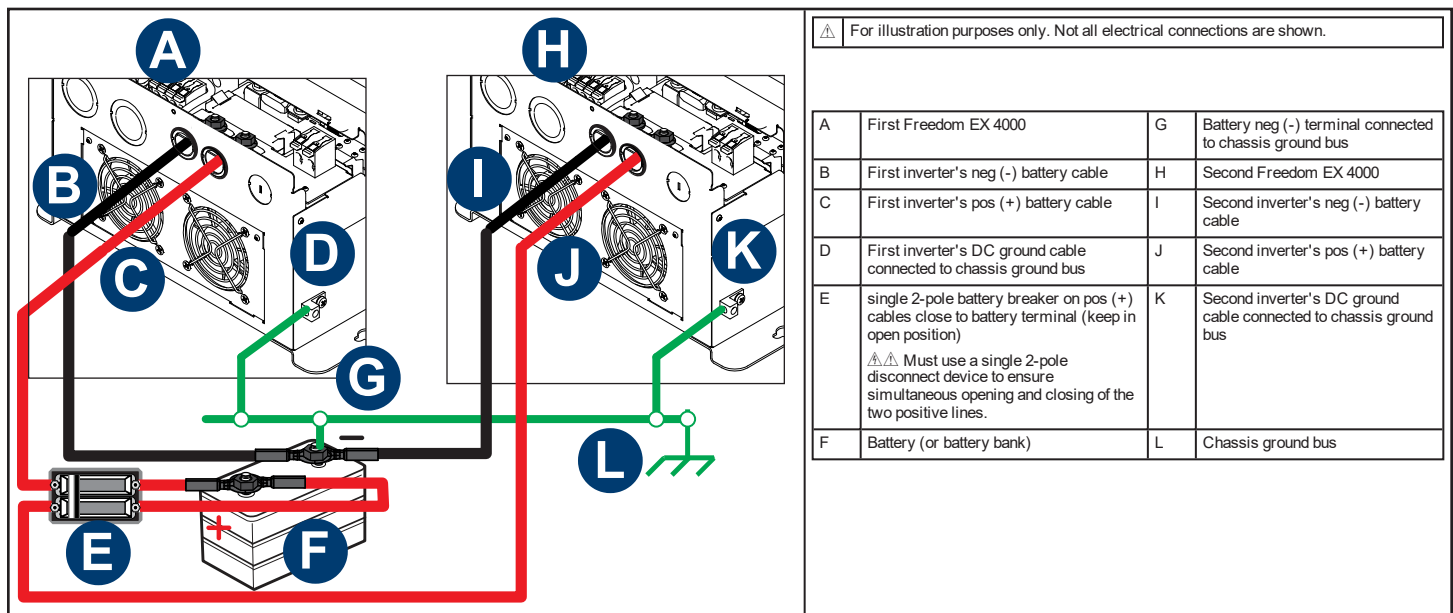

## DC Grounding

### To connect the DC ground:

1. The equipment grounding lug (DC ground lug) on the DC end of the Freedom EX 4000 is used to connect the chassis of the Freedom EX 4000 to your system's DC negative connection or grounding bus point as required by electrical regulations.
2. Use copper wire that is either bare or provided with green insulation. Do not use the DC ground lug for your AC grounding. See the AC wiring instructions in this section.
3. Follow the guidelines below that correspond to the specific type of installation. These guidelines assume you are using the DC supply cable and fuse sizes recommended in this guide. If you are using different sizes, refer to the applicable installation code for DC grounding details.
4. See *Figure 4* for the location of the DC ground lug. Make sure to tighten the bolt on the DC ground lug to a torque of 23 in-lb (2.6 N-m) of force. Apply an anti-corrosion compound to the copper wire prior to connecting to the DC ground lug.

**Recreational Vehicle** Use 8AWG minimum-sized, stranded copper wire rated minimum 75 °C and connect it between the Chassis Ground lug and the vehicle's DC grounding point (usually the vehicle chassis or a dedicated DC ground bus). See regulatory references below.

**Marine** Use copper wire that is bare or has insulation rated minimum 105 °C, and connect it between the Chassis Ground lug and the boat's DC grounding bus or engine negative bus. Use a wire of gauge 3AWG minimum (one gauge less than the DC supply cable size). See regulatory references below.

### Regulatory references

For DC voltage systems under 50 VDC in an RV installation, an 8AWG copper bonding conductor would be acceptable for the inverter/charger/converter enclosure ground bonding only per UL458 §63.6; §30.10 standard [ $\leq 150$  mV @ 30A connection, per §63.9; §63.10] and per ANSI/RVIA LV code §2-5.1 Bonding Voltage Converter Enclosures. The "house" battery system must, however, be ground bonded per ANSI/RVIA LV code §2-4 Auxiliary Battery Grounding; and For DC voltage systems under 50 VDC in a marine installation, [UL458 §SA7.2] a DC Grounding conductor shall not be smaller than one size under that required for current carrying conductors supplying the device per ABYC E-11 §11.16.2 but not less than 8AWG [USGC 46 CFR §111.05-31].

## Step 7: Connecting to Port(s) on the Freedom EX 4000

Figure 22 Freedom EX 4000 Ports

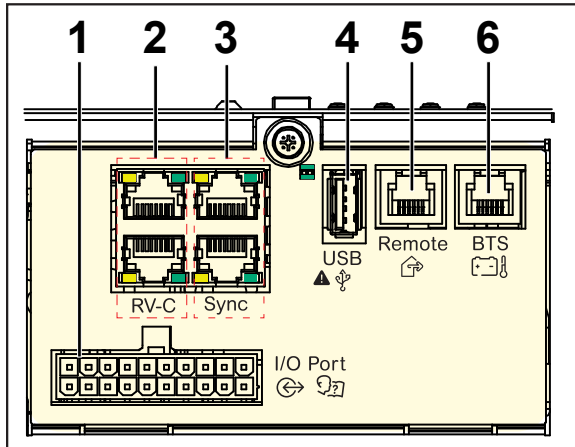

1	20-pin CC (communications and control) port
2	RV-C ports
3	Sync ports
4	USB port
5	Remote port
6	BTS port

### NOTICE

#### EQUIPMENT DAMAGE

Do not use pinouts (see Figure 25 ) that are designated "DO NOT USE" to connect to equipment not currently supported.

**Failure to follow these instructions can result in equipment damage.**

### NOTICE

#### EQUIPMENT DAMAGE

Use the USB port only for firmware upgrades. Do not use for powering or charging USB devices.

**Failure to follow these instructions may void the warranty and damage equipment.**

## Connecting to the 20-pin Communications and Control (20-pin CC) Port

The 20-pin CC port of the Freedom EX 4000 accepts a corresponding Communications and Control 20-pin Harness (see Figure 23 ). For marine vessels, the NMEA 2000 protocol for marine communication systems will be introduced as an added capability in upcoming releases.

Figure 23 20-pin Communications Harness

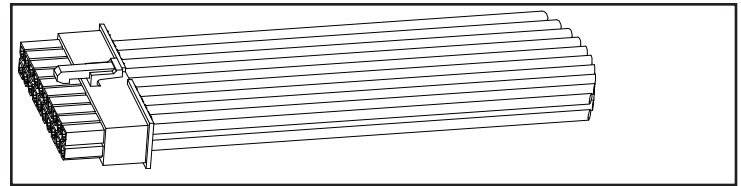

Figure 24 20-pin Communications Harness Pinouts

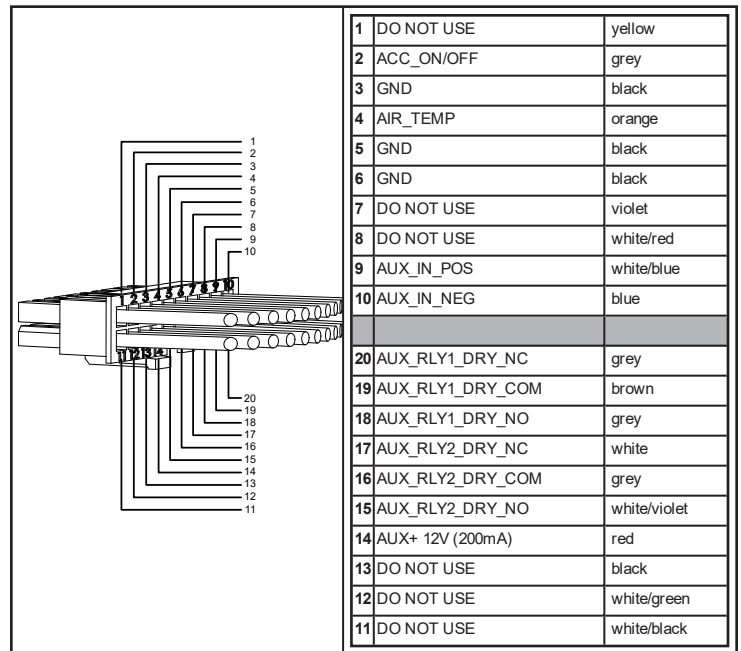
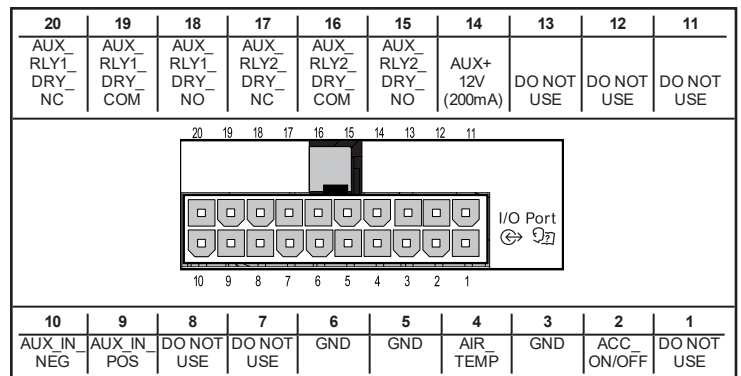

Figure 25 I/O Port



## Connecting to the RV-C Ports

The RV-C ports of the Freedom EX 4000 accepts a corresponding standard patch cable with an RJ-45 (see *Figure 27*) connector.

**NOTE:** Do not connect the Sync cable to these ports if you are stacking two units. The inverter will stop operating and generate an event code 66 or 69. Remove the cable connections immediately.

Figure 26 RV-C ports

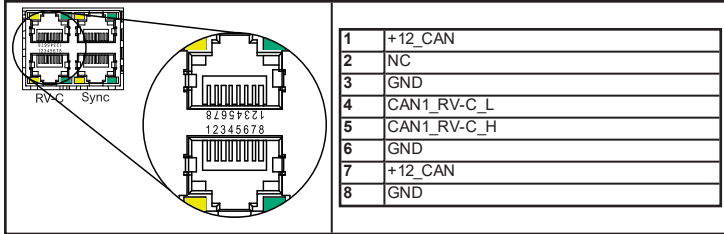

Figure 27 RJ-45 connector pinouts/wire colors

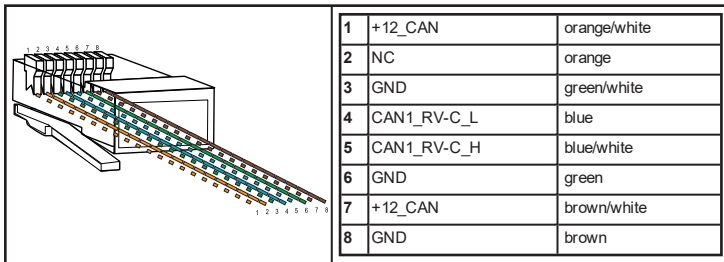
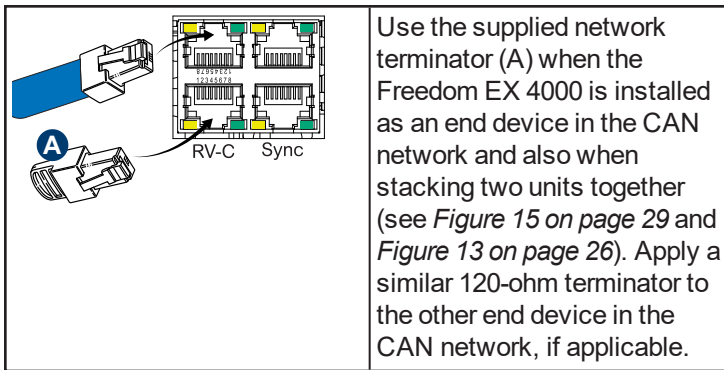

Figure 28 RJ-45 network terminator



## Connecting to the USB Port

The USB port is reserved for firmware updates to the Freedom EX 4000 and must not be used for powering and charging USB devices.

## Connecting to the Remote Port

The Freedom EX 4000 can accommodate the Remote panel (PN: 808-0817-03, sold separately).

To connect the remote panel to the remote port:

1. Route and wind the cable two times through the ferrite core (supplied with the remote panel) before extending the connector to the port. The ferrite core has to be closest to the Freedom EX 4000's RJ12 Remote port .
2. Plug the remote panel unit's cable connector to the RJ12 Remote port on the unit. For the location, see *Figure 22 on page 37*.
3. Plug the other connector to the Remote panel unit.

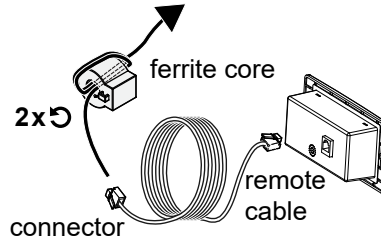

**NOTE:** When the remote panel is connected, turn the inverter/charger/converter's Power button to Standby (up position). This allows the remote panel to control the inverter/charger/converter's power status.

## Connecting to the BTS Port

Installing a BTS (battery temperature sensor) (optional, PN: 808-0232-01) extends the life of a battery by preventing overcharging in warm temperatures and undercharging in cold temperatures. With a BTS monitoring the battery temperature, the voltage delivered to the battery is adjusted according to the battery's actual temperature.

The BTS (battery temperature sensor) has a self-adhesive backing and attaches to the side of the battery. A 25-foot (7.6 m) cable is supplied with this optional accessory.

**NOTE:** Prior to mounting the BTS, route and wind the BTS cable two times through the ferrite core (supplied with the BTS) before extending the connector to the port and the sensor to the battery. The ferrite core has to be closest to the Freedom EX 4000's BTS port.

Figure 29 BTS with Cable

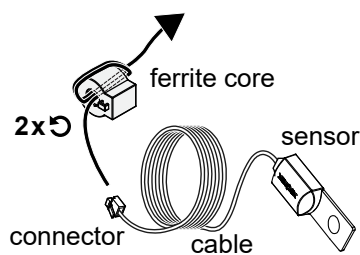

### NOTICE

#### EQUIPMENT DAMAGE

Use only the Freedom EX 4000-compatible BTS (battery temperature sensor). To order, call customer service and order PN: 808-0232-01.

**Failure to follow these instructions can result in equipment damage.**

## Mounting Options

You can mount the optional BTS (battery temperature sensor) in one of two ways:

- Mounting the sensor to the negative battery post allows the internal battery temperature to be sensed and provides the most accurate results (*on page 39*).
- Attaching the sensor to the side of the battery using the self-adhesive backing also provides good results in most situations (*on page 40*).

### To mount the sensor on the negative battery terminal:

1. Select the battery to be monitored. The BTS should be connected to the battery bank that is directly connected to the Freedom EX 4000.
2. Switch off all devices operating from the battery, or open the battery switch (if present) to disconnect the battery.
3. Wait ten minutes for any explosive battery gases to dissipate.
4. Remove the nut, lock washer, and flat washer that connect the existing wiring ring terminal to the battery negative terminal stud.
5. Move or reorient the existing wiring ring terminal on the battery negative terminal stud, so there is a flat surface on which to seat the BTS mounting plate.
6. You may need to bend the ring terminal crimp and/or wires slightly downward to allow the sensor to seat flush to the top surface of the upper ring terminal.
7. Mount the sensor directly on top of the ring terminal, as shown in *Figure 30*, then the flat washer, lock washer, and nut. Tighten the terminal nut to a torque of 80 in-lb (9 Nm). A loose connection can cause excessive heating. Always follow your battery manufacturer's torque specifications.
8. Check to ensure that the sensor and all wires are held firmly and cannot be moved.
9. Turn the battery switch on again (if you opened it in Step 2.)
10. Route the sensor cable to the Freedom EX 4000 and plug it into the BTS port. Secure the cable along its length.

Figure 30 BTS Mounted on the Negative Battery Terminal

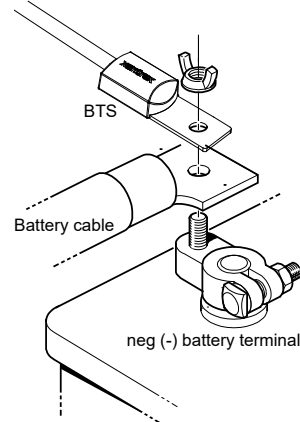

### To mount the sensor on the battery case:

### ⚠ WARNING

#### ELECTRICAL SHOCK AND BURN HAZARD

Do not drill into the battery.

**Failure to follow these instructions can result in death, serious injury, or equipment damage.**

## Basic Installation Procedures

1. Select the battery to be monitored. The BTS should be connected to the battery bank that is directly connected to the Freedom EX 4000.
2. Switch off all devices operating from the battery, or open the battery switch (if present) to disconnect the battery.
3. Wait ten minutes for any explosive battery gases to dissipate.
4. Select a side suitable for attaching the sensor.

Figure 31 BTS Mounted on the Battery Case

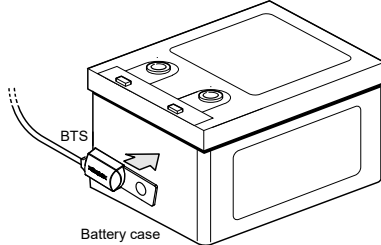

5. The surface where the sensor is to be mounted must be flat and free from reinforcing ribs or other raised features. This surface must be in direct internal contact with the battery electrolyte. Do not install the sensor near the top of the battery or on the battery's top surface.
6. Clean the selected area thoroughly to remove any oil or grease that could prevent the sensor from adhering to the battery case. Allow the battery case to dry thoroughly.
7. Peel the protective backing from the self-adhesive strip on the rear of the sensor.
8. Press the sensor firmly against the clean side of the battery to fix it in place, as shown in *Connecting to the BTS Port*.
9. Route the sensor cable to the Freedom EX 4000 and plug it into the BTS port. Secure the cable along its length.

## Connecting to ACC Signal

With the Communications and Control 20-pin Harness (see *Figure 24 on page 37*), the Freedom EX 4000 can be wired to inhibit inverter operation in the absence of a vehicle's (or vessel's) +12VDC ignition control signal. This feature can avoid unnecessary battery drain that would otherwise occur if the inverter/charger/converter was operated without a charging source such as the vehicle alternator.

1. Ensure that AC and DC power are both OFF.
2. Ensure the vehicle's (or vessel's) ignition is turned to OFF position. It is highly recommended to remove battery power by disconnecting the vehicle's battery cables. Refer to the vehicle's (or vessel's) user manual for proper instructions on how to disconnect the battery cables.
3. Locate the vehicle's (or vessel's) ignition control wire from its ignition circuit. This wire must be fused appropriately at no more than 5 A. Refer to the its user manual for guidance.

### Description of Ignition Control Features

For information about the features and instructions on changing the ignition control features, see *Configuration on page 1*.

Table 6 Ignition Control Features

<b>Ignition Auto-on (AUE)</b>	This setting allows the inverter/charger/converter to operate (Battery mode) automatically when an ignition control wire is connected to the ACC input via pin 2 of the Communications and Control 20-pin Harness and a valid ignition signal is constantly detected. The inverter works in tandem with the vehicle's ignition circuit.
<b>Ignition Lock-out (LUE)</b>	This setting allows the inverter to operate (Battery mode) when an ignition control wire is connected to the ACC input terminal via pin 2 of the Communications and Control 20-pin Harness and a valid ignition signal is constantly detected. When enabled, you have to manually press the Power button on the display panel to operate the inverter.
<b>Off (OFF)</b>	To completely disable the ignition control features do the following: Set Ignition Control to Off (OFF) using the Select buttons on the Display panel.

## Step 8: Battery Configuration

After all wiring is done, the next major step is to configure the battery type.

1. Switch open the battery's DC breaker to disconnect DC power. In a Stacking configuration with two inverter/chargers, switch open the single 2-pole battery breaker to disconnect DC power.
2. Close the input and output AC circuit breakers on the vehicle's AC load distribution panel. This will allow AC shore power to pass-through and energize the Freedom EX 4000.

3. Observe the green AC source LED  on the top panel. It should turn on and remain steady.

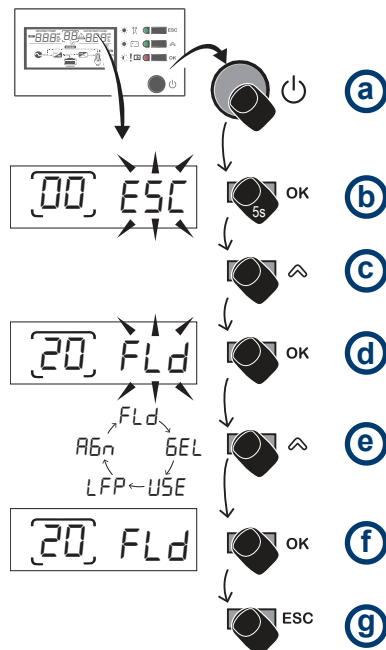

4. Configure the Battery Type using the Remote Panel.
  - a. Press the Power button.
  - b. Press and hold the OK button for 5 seconds until ESC starts flashing on the screen.
  - c. Press the Scroll button to browse through the different settings until you get to "20" which is the Battery Type setting.
  - d. Press the OK button to confirm.
  - e. Press the Scroll button to browse through the different battery types until you get to the corresponding battery type of your house battery.
  - f. Press the OK button to confirm the selection.
  - g. Press the ESC button to exit configuration.
5. Switch open the input and output AC circuit breakers to disconnect shore power.

## Step 9: Testing Your Installation

### WARNING

#### ELECTRIC SHOCK HAZARD

Pressing the Power button to turn the Freedom EX 4000 inverter to Standby on the display panel does not disconnect DC or AC input power to the Freedom EX 4000. If shore power is present at AC input terminals, it will pass through to the AC output.

**Failure to follow these instructions can result in death, serious injury, or equipment damage.**

There are two tests to be performed. The first test verifies that the Freedom EX 4000 is inverting DC battery power and delivering AC power to its output.

The second test is intended for installations where AC input and output is hard wired to the Freedom EX 4000. This test verifies that the Freedom EX 4000 transfers from inverter power to shore power when shore power is present.

**NOTE:** Shore power (pass-through) refers to the AC input power from a utility grid, generator or external AC source.

When you are ready to test your installation and operate the Freedom EX 4000, close the DC fuse and Disconnect or the DC circuit breaker to supply DC power to the Freedom EX 4000.

### Testing in Battery Mode

To test the Freedom EX 4000:

1. For hard wired installations, ensure shore power is not present. Open the input AC breakers.
2. Close the battery disconnect device (or the 2-pole battery breaker if in Stacking configuration) to energize the inverter/charger with battery power.
3. Press the Power button to turn the inverter/charger/converter on.

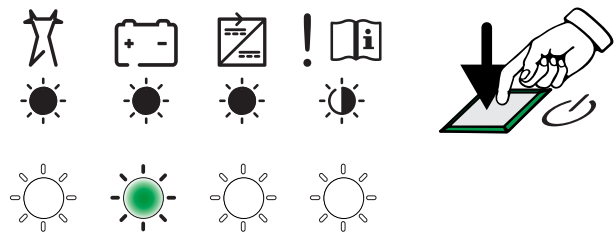

4. Plug a test load, such as a lamp within the power rating of the inverter/charger/converter into an AC outlet downstream from the AC distribution panel
5. Turn the lamp on to verify that it operates.

If the lamp operates, your installation is successful. If your installation has AC input and output hard wired to the Freedom EX 4000, proceed to *Testing in Shore Mode*.

If the status LED on the display panel glows red, see the Troubleshooting chapter.

## Testing in Shore Mode

### To test the Freedom EX 4000:

- With the test load from the previous test still connected and operating, connect the shore power source.
- The Freedom EX 4000 transfers the test load to shore power. The green LED indicating shore mode turns on.
- If the test load operates, your installation is successful.

**NOTE:** If the Power button on the Freedom EX 4000 is turned ON, the Freedom EX 4000 will automatically supply the appliances with inverter power if the shore power source fails or becomes disconnected.

If the Power button on the Freedom EX 4000 is turned ON and shore power voltage is too low (less than 80 VAC<sup>1</sup>), the unit will transfer to inverter power to continue running your appliances.

**NOTE:** Whether or not the Power button is turned ON, shore power will pass through the Freedom EX 4000 to the output when shore power is within normal operating range. When charging is enabled, the unit also starts charging the battery after the transfer to shore mode.

**NOTE:** In the event of low or no battery voltage, shore power will pass through the Freedom EX 4000 to the output even when shore power is outside the normal operating range and battery DC terminals will rise to a voltage proportional to AC input voltage (42VDC at nominal, 120VAC input).

<sup>1</sup> This default value is configurable.

# Marine Installation

Figure 32 Typical Marine Installation

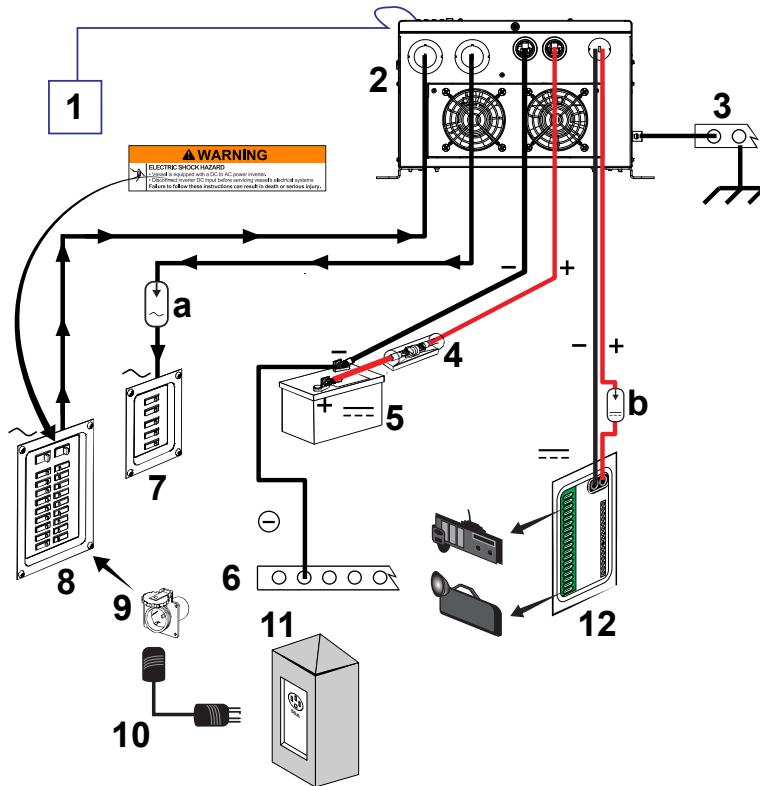

1	Communications and Control 20-pin Harness
2	Freedom EX 4000
3	Equipment ground – Engine negative bus / DC ground bus
4	DC fuse/disconnect/DC circuit breaker
5	48V deep cycle battery bank and protected by a DC fuse in the positive cable
6	Equipment ground – DC ground bus
7	AC inverter load panel with AC-rated SPD/TVSS (a) and branch circuit breakers that supply only loads that run off the Freedom EX 4000
8	AC source shore panel that includes a max 50A breaker
<b>IMPORTANT</b>	
To the installer: Affix the provided safety label to the source panel where the Freedom EX 4000 will be connected to.	
9	Shore power receptacle – AC power supplied from a shore power connector
10	Vessel dogbone adapter and/or power extension cord
11	Dock site power panel with electrical receptacles
12	Fused 12VDC load sub-panel with a DC-rated SPD/TVSS (b) <b>⚠ DO NOT CONNECT DC LOAD SUB-PANEL NEG(-) TO DC ground bus.</b> <b>NOTE:</b> The NEG(-) 48V and 12V are bonded internally.

## Drip Shield Installation

The drip shields help to protect the unit from dripping or splashing liquids, which will cause a shock hazard when moisture comes in contact with electrical circuits in the unit. The drip shields are especially useful in marine installations where water from condensation, rain, or sea may come into contact with the Freedom EX 4000.

### **⚠️ WARNING**

#### **ELECTRICAL SHOCK HAZARD**

Place this unit in normally dry areas only. Operating the unit under wet conditions may expose you to a shock hazard. Installing drip shields may not entirely protect you from this hazard. Do not operate the unit when it is wet.

**Failure to follow these instructions can result in death, serious injury, or equipment damage.**

You may purchase the Drip shield set by contacting customer support. When ordering, mention part number 808-9004.

Figure 33 Drip shields over deck mounted units

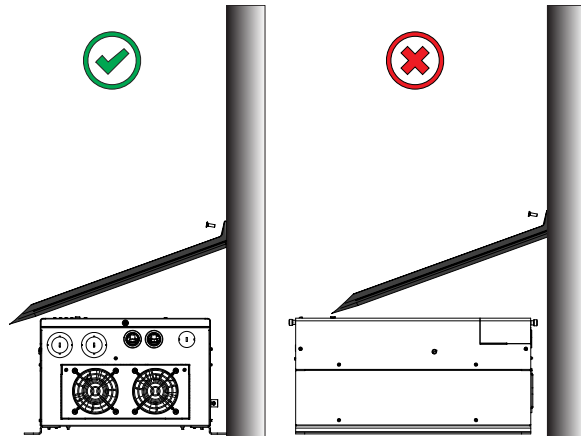

#### To install the drip shields:

1. Gather the ten #6 pan-head steel screws needed to fasten a single drip shield to a wall.
2. Locate an appropriate setting for the drip shields above the Freedom EX 4000 making sure you cover the entire width of the unit and not the length as shown in *Figure 33*. On wall mounted unit, make sure the width of the unit is covered as shown in *Figure 34*.
3. Fasten the screws through the holes in the drip shield into the wall. See *Figure 33*.

Figure 34 Drip shields over wall mounted units

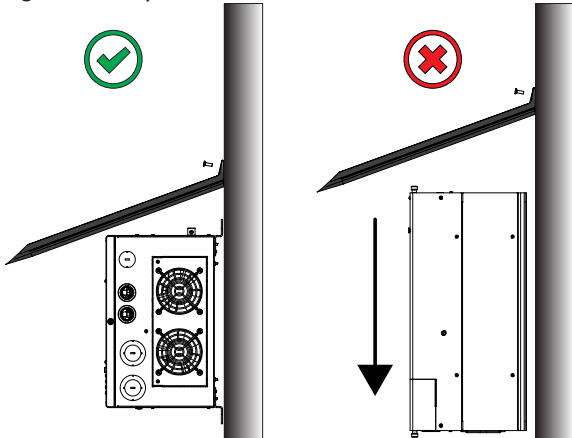

# Physical Specifications

Table 7 Physical specifications

	Freedom EX 4000
Supported Battery Types	Flooded (default), Gel, AGM, Lithium Ion, Custom
Battery Bank Size	440–10000 Ah
Electrical Terminals	<b>Two 48V DC terminals</b> - M8 bolt with nut and washers for [-]/[+] <b>Two 12V DC terminals</b> - Screw-type connections for [-]/[+] <b>Two AC terminal blocks</b> - No-tool spring-clamp connections for L1   N   L2   Gnd
Communication Ports	<b>Two RV-C ports</b> - RJ-45 receptacles <b>Two Sync ports</b> - RJ-45 receptacles <b>Remote port</b> - RJ-11 receptacle <b>BTS port</b> - RJ-11 receptacle <b>USB port</b> - standard USB receptacle to be used for firmware updates only <b>COM port</b> - 20-pin receptacle to be used with 20-pin harness optional accessory
Information Panel	<b>Status LEDs</b> and <b>Power button</b> are located on the top panel of the unit. See " <i>LED Status Indicators and Power Button</i> " on page 1 for information on the LED.
L × W × H	434mm × 354mm × 205mm (17.1" × 14" × 8.1")
	<b>NOTE:</b> Width includes flanges. Length includes captive nut panel screws.
Net Weight	36 kg (79.4 lbs)

Table 8 Product dimensions

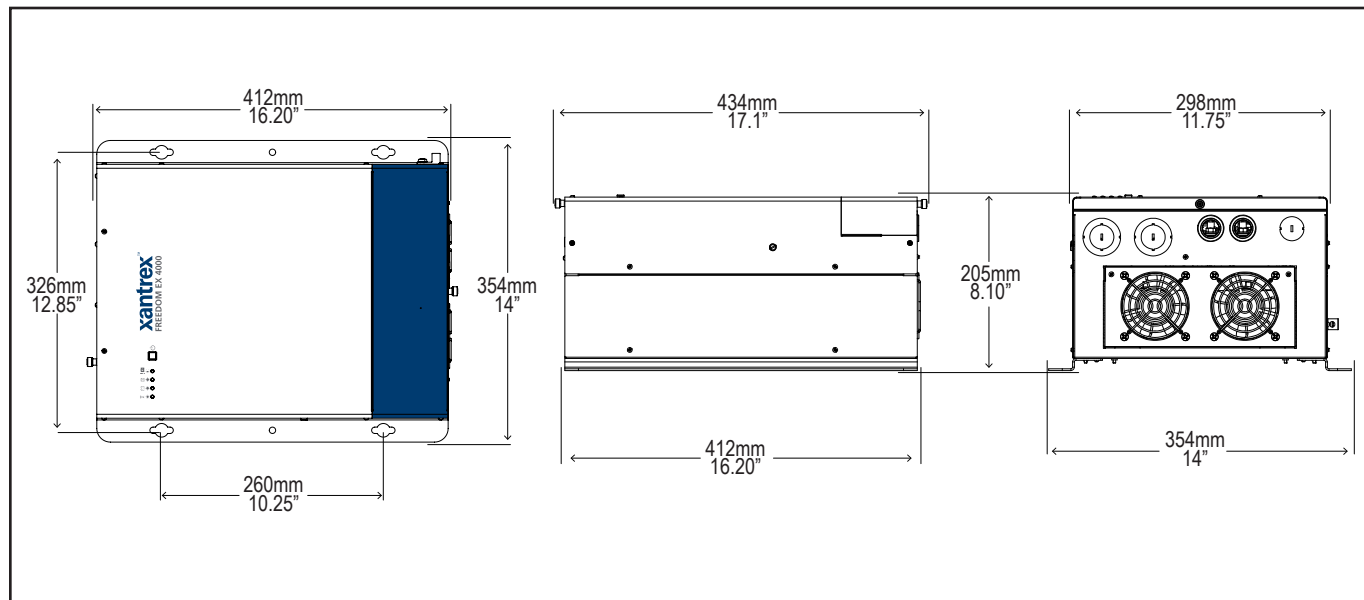

# Environmental Specifications

Table 9 Environmental specifications

	Freedom EX 4000
Rated Temperature Range	0–40 °C (32 –104 °F)
Operating Temperature Range <sup>a</sup>	-10 –60 °C (14 –140 °F), with output derated above 40 °C (104 °F)
Storage Temperature Range	-40 –70 °C (-40 – 158 °F)
Humidity: Operation/Storage	5–95% RH, non- condensing
Ingress Protection Rating	IP20

<sup>a</sup>Operation may be limited based on the battery chemistry. For example, Lithium Iron Phosphate batteries have a limited charging temperature range. Follow specific battery manufacturer recommendations for the applicable chemistry.

# System Specifications

Table 10 System specifications

	Freedom EX 4000
Transfer relay rating (A <sup>®</sup> )	40A (continuous) 50A (max)
Transfer time (milliseconds)	
Shore to inverter:	<10 milliseconds
Inverter to shore:	<10 milliseconds with a 20-second delay
Transfer voltage (V)	
Shore to inverter:	Shore voltage less than 60V(min) - 80V(default) - 115V (max)
Inverter to shore:	Shore voltage greater than above value + 2V hysteresis
Shore to inverter:	Shore voltage greater than 125V(min) - 138V (default) - 144V(max)
Inverter to shore:	Shore voltage less than above value – 2V hysteresis
Waveform	True Sine Wave
Peak Efficiency	95.5 %
Idle consumption (DC-DC converter has no load. Remote display, RV-C control, and BTS are connected.)	< 0.3 W (Power button on unit is Off (Standby)) < 8 W (Power button on unit is On, inverter mode disabled, charger mode enabled) < 30 W (Power button on unit is On, inverter and charger mode enabled)
Cooling	Fan, activated by any of the following: <ul style="list-style-type: none"> <li>■ High internal temperature</li> <li>■ High AC output power</li> </ul>

<sup>e</sup>Circuit breakers shall not carry more than 80% of their UL current rating continuously.

Table 11 DC input for inverting

	Freedom EX 4000
Nominal voltage	48 VDC
Operating voltage	40–64 VDC
Maximum current at full load	130 ADC

Table 12 DC output for charging

	Freedom EX 4000
Nominal voltage	48 VDC
Maximum voltage	64 VDC
Maximum charge rate	80 A single unit 160 A when parallel or series stacked <sup>f</sup>
Power factor corrected charging	PF (0.98)

Table 13 DC output for 12 VDC load

	Freedom EX 4000
Nominal output voltage	13.5 VDC
Maximum output current	45A (continuous @ 25 °C ambient) 50A (15 minutes @ 25 °C ambient) 70A (6 minutes @ 25 °C ambient)

Table 14 AC output for inverting

	Freedom EX 4000
Output voltage options	105 to 130 VAC
Continuous power (W <sup>g</sup> )	4000 W @ 40 °C with output derated above 104 °F (40 °C)
Continuous current	33.3 A
Surge power (5 sec)	8000 W
Output Frequency	60 Hz
GFCI protection <sup>h</sup>	customer-provided
Wave shape	True Sine Wave
Total Harmonic Distortion	< 5% at rated power

Table 15 AC output for series-stacked pair inverters

	Freedom EX 4000
Output voltage options	210 to 260 VAC
Continuous current	33.3 A
Surge power (5 sec)	16000 W
Output Frequency	60 Hz

Table 16 AC output for parallel-stacked pair inverters

	Freedom EX 4000
Output voltage options	105 to 130 VAC
Continuous current	66.6 A
Surge power (5 sec)	16000 W
Output Frequency	60 Hz

Table 17 AC input for charging and pass-through

	Freedom EX 4000
Input voltage single-phase (L1-N and L2-N)	80–138 VAC [(120 V nominal), default range] 60–155 VAC [(120 V nominal), allowable range]
Input voltage split-phase <sup>k</sup> (L1-L2)	160–276 VAC
Input breaker	50A, double-pole
Input frequency range	54.5–65 Hz (default) 44–68 Hz (allowable)
Peak efficiency	91%
Full load efficiency	≥ 86%

Table 18 Accessories

	Product Number
BTS (battery temperature sensor)	808-0232-01
Network terminator	809-0901
Ferrite core	023-0189-01
Remote panel	808-0817-03
20-pin harness	808-0820
Drip shield	808-9004

**NOTE:** Contact Xantrex or your dealer to order these accessories.

<sup>f</sup> Contact Xantrex prior to stacking two Freedom EX 4000 units together. Stacking configuration via USB is a required step to enable stacking.

<sup>g</sup> Power derates to 85% when output voltage is set to 110/108 VAC.

<sup>h</sup> See Ground Fault Circuit Interrupters (GFCIs) on page 14 for approved device/s.

<sup>i</sup> Contact Xantrex prior to stacking two Freedom EX 4000 units together. Stacking configuration via USB is a required step to enable stacking.

<sup>j</sup> Contact Xantrex prior to stacking two Freedom EX 4000 units together. Stacking configuration via USB is a required step to enable stacking.

<sup>k</sup> L1-N must be within the single-phase qualification voltage range, 80–138 VAC, for split-phase to operate in a split-phase configuration.

# Regulatory Approvals

Table 19 Regulatory approvals

	Freedom EX 4000
Safety	CSA Certified to CSA 107.1 UL458 and UL458 Marine Supplement (drip shield with product number 808-9004 required) ABYC E-11, A-31, A-32
EMC	CFR 47, (FCC) Part 15, Subpart B, Class B CAN ICES-3(B)/NMB-3 (B)



This page is intentionally left blank. [2]

# xantrex™

A MISSION CRITICAL ELECTRONICS BRAND

Smart choice for power™

<http://www.xantrex.com/>

(Toll Free USA/Canada) +1 800 670 0707

(Outside USA/Canada) +1 408 987 6030

975-0998-01-01 Rev D

30948

Printed in: