



# OCTOPUS

SELECTION & INSTALLATION GUIDE



## AUTOPILOT REVERSING PUMPS (ORB Manifold)

### A. SELECTION:

The Octopus autopilot reversing pump is a very reliable and efficient pumpset that will give you years of trouble free service. The unit is a patented single piston radial pump with an optional adjustable displacement and must be installed correctly to function well. The pump unit has a shut off manifold attached to the front face, which facilitates pump service without loss of hand steering.

This guide applies to the following pump models:

Model Number	Description
AF1012	1000cc/min 12VDC Pump
AF1024	1000cc/min 24VDC Pump
AF1212	1200cc/min 12VDC Pump
AF1224	1200cc/min 24VDC Pump
AF2012	2000cc/min 12VDC Pump
AF2024	2000cc/min 24VDC Pump

For details of the part numbering scheme, please refer to the diagram below.

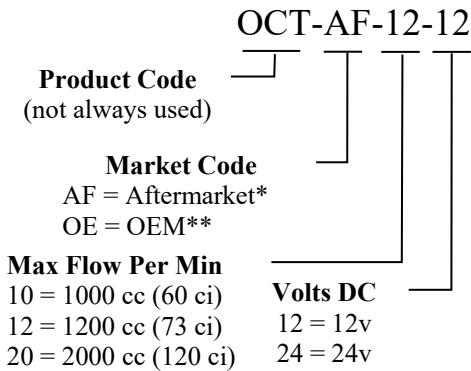

- \* Adjustable Displacement
- \*\* Fixed Displacement

**OCTOPUS PRECISION PRODUCTS - VANCOUVER CANADA**  
**TEL 604 940 2010 - FAX 604 952 2650 – website [www.octopusdrives.com](http://www.octopusdrives.com)**

**SELECTION & INSTALLATION GUIDE (Continued)**  
**AUTOPILOT REVERSING PUMPS (ORB Manifold)**

Note that it is **crucial** to maintain the correct steering cylinder speed in order to achieve optimum autopilot performance. If your steering cylinder is too large for the 2000cc/min reversing pump, you may be advised to use a larger model of pump such as one of the OCTOPUS CRA or CRB series.

The reversing pump is designed to operate on a balanced hydraulic system where the volume of oil on each side of the steering cylinder is the same. (The cylinder is unbalanced if the actuating shaft only extends from the front of the cylinder, when the cylinder is fully retracted. If the actuating shaft extends from both the front and the rear of the cylinder, it is a balanced cylinder). Check that your cylinder is balanced. If you do not have a balanced system you need to either change the cylinder to a balanced one or add an unbalanced valve to the system OCTOPUS part number OC17SUK03.

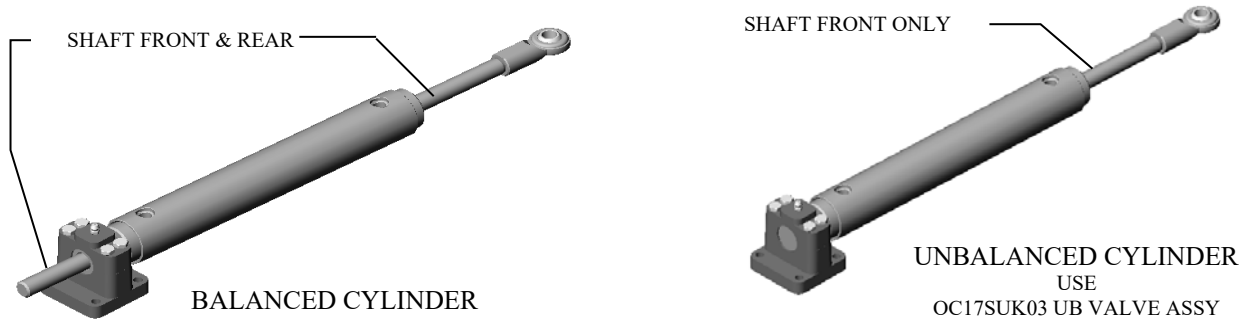

**B. INSTALLATION:**

Mount the pump anywhere in the vessel where it is close to the tubes connecting the hand steering helm pump to the rudder cylinder. Preferably this should be on a horizontal surface in a clean dry area. The best location is usually in the engine room. Be careful not to mount the pump on a flimsy panel as this may resonate and amplify any noise the pump makes.

**C. HYDRAULIC CONNECTIONS:**

In any hydraulic system it is important to use flexible hoses between the pump and the tubing to protect the tubing against fatigue and also to isolate the more rigid tubing/structure from any noise that the pump may generate. The pump is supplied with a shut off manifold, this manifold has 3 pairs of ports SAE-05 ORB on front face and top face. You can choose to use one of pair and plug the other one. It is most important to keep all dirt, including dust, out of the system during installation.

There are different configurations of connections Figs showing below:

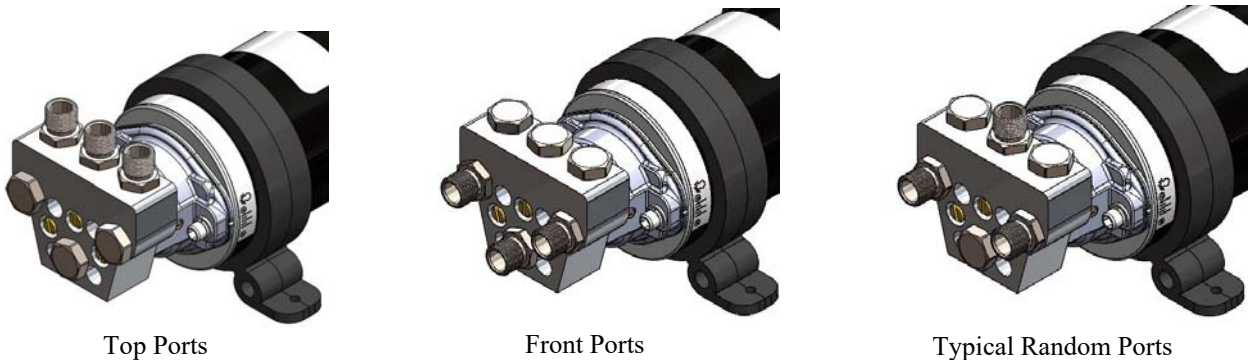

## SELECTION & INSTALLATION GUIDE (Continued) AUTOPILOT REVERSING PUMPS (ORB Manifold)

### C1. CONNECTING THE 2 PRESSURE LINES:

With the pump mounted on a horizontal surface, the two steering ports on the manifold must be connected with hoses, to the tubes connecting the hand steering helm pump to the rudder cylinder.

### C2. CONNECTING THE VENT/DRAIN LINE:

The middle port on the front face of the manifold **MUST** be connected, with a hose, to the existing reservoir on the steering system. This is either a separate pressurized reservoir tank or the steering helm itself. There is usually a port on the bottom of the helm pump. If there are 2 helm stations, use the most convenient. The correct installation of this **VENT/DRAIN LINE** is crucial for the operation of the pump.

Note :

1. Ensure that the existing hydraulic system incorporates non-return (lock out) valves in the helm pump (check with the steering system manufacturer); if it does not, then suitable valves must be fitted. Most North American steering systems do install non-return valves.

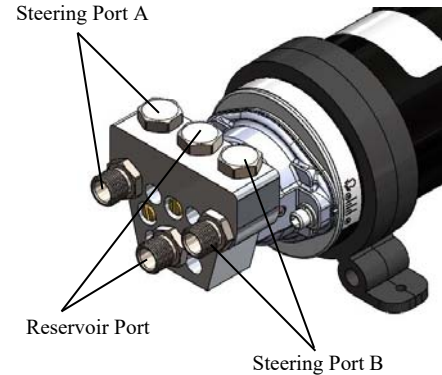

### D. FILLING AND PURGING THE SYSTEM:

After installing the Octopus pump the steering system can be filled following the steering system manufacturer's instructions. The Octopus pump can then be started using the following procedure:

**Important Note:** The pumps are shipped from the factory with the brass needle valves in the "OPEN" position. Closing the needle valves is only done when the pump requires service. This allows the pump to be separated from the manifold without losing manual steering. See Section G – Service for detailed instructions.

To "CLOSE" – turn needle screws all the way in clockwise.

To "OPEN" – turn needle screws 2 turns counter clockwise from CLOSED.

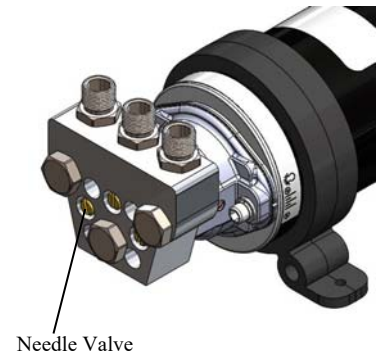

- Step I: Ensure the 3 brass needle screws on the front of the manifold are in the "OPEN" position.
- Step II: Turn the steering wheel (direction not important) until the rudder is hard over. At hard over apply pressure to the steering wheel forcing the rudder against the rudder stop.
- Step III: Whilst holding the rudder against the rudder stop via the steering wheel, energize the pump by applying system voltage on the 2 motor wires, occasionally reversing the polarity.
- Step IV: Repeat steps ii & iii until the pump runs smoothly, driving the rudder in both directions.
- Step V: Leave needle screws in the "OPEN" position during normal pump operation.

**SELECTION & INSTALLATION GUIDE (Continued)  
AUTOPILOT REVERSING PUMPS (ORB Manifold)**

**E. ADJUSTING PUMP FLOW:**

The Octopus pump is shipped set at its maximum rated flow. When facing the pump body, the left-hand socket screw hole is round and used as a pivot point, the right hand socket screw hole is slotted and used for flow adjustment. On the right hand side there is a graduated scale on the motor end shield and a raised line marker on the pump body. If your rudder speed is too fast the flow can be reduced using the following procedure:

- I. Loosen the 2 socket screws that hold the pump body onto the front endshield of the motor 1 full turn. Do not loosen the bolts any further or the pump body oring may fall out of position. (4mm Allen key wrench required).
- II. Slide the right hand side of the pump body down to a lower setting on the scale.
- III. Re-tighten the 2 socket screws to 70 in-lb.

It may be necessary to try several settings to get the best autopilot performance. If your system is pressurized with air, it should be depressurized during the adjustment procedure.

For additional information see Service Procedure SP002 – Flow Adjustment Procedure.

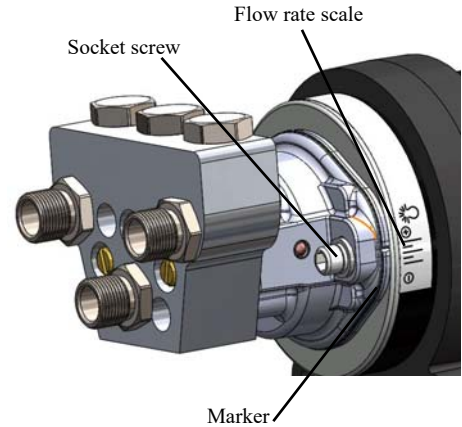

FLOW ADJUSTMENT

**F. ELECTRICAL CONNECTIONS:**

Follow the autopilot manufacturer's instructions when connecting up the Octopus pump. Correct sizing of cable is important. You have purchased the most efficient autopilot pump available today and it is not to your advantage to compromise its performance by using undersize cable. Ensure all electrical connections are properly made.

**G. SERVICE:**

The Octopus pump has only 3 moving parts and requires no routine service. Installed correctly it will give many thousands of hours of trouble free operation. If it becomes necessary to service the pump, it can be removed from the vessel without draining the steering system. To remove the pump, use the following procedure:

- I. Close the 3 brass needle valves positioned on the shut off manifold on the front of the pump by turning all the way in clockwise.
- II. Remove the 4 socket screws that hold the shut off manifold to the pump body. (4mm Allen key wrench required).
- III. Disconnect the electric cables and the bolts holding the pump to the hull structure.
- IV. The pump is now free and can be removed for service.

**SELECTION & INSTALLATION GUIDE (Continued)**  
**AUTOPILOT REVERSING PUMPS (ORB Manifold)**

**H. TROUBLESHOOTING:**

If the unit fails to operate after installation is complete, check for the following common causes.

1. Motor does not run:

- I. No voltage applied to motor. (check voltage at motor with voltmeter).
- II. Autopilot not switched on correct setting. (check autopilot manual).

2. Motor runs but pump does not move the rudder:

- I. System not filled with oil. (Fill and purge system).
- II. Shut off valve closed. (Open needle valves 2 full turns each counter clockwise from fully closed).
- III. Pump adjustment set too low. (Adjust flow setting up).
- IV. Hydraulic connection incorrect. (Check that 2 side ports from shut off manifold connect to cylinder hoses).
- V. Vent/Drain line (middle port on shut off manifold) not connected. (Must connect to reservoir).
- VI. Pump has been dismantled and not assembled correctly. (Ensure piston is not backwards).

**I. SPARE PARTS:**

The following parts are available as spares and are recommended for vessels undertaking extensive passages or when autopilot downtime must be kept to an absolute minimum.

- |   |                  |
|---|------------------|
| 1. 12V Type 1 motor module assembly kit for 1012 & 1212 pump      | part # OC14SUK20 |
| 2. 12V Type 2 motor module assembly kit for 2012 pump             | part # OC14SUK21 |
| 3. 24V Type 2 motor module assembly kit for 1024, 1224, 2024 pump | part # OC14SUK22 |
| 4. 1.0L pump module assembly kit for 1012 & 1024 pump             | part # OC14SUK23 |
| 5. 1.2L pump module assembly kit for 1212 & 1224 pump             | part # OC14SUK24 |
| 6. 2.0L pump module assembly kit for 2012 & 2024 pump             | part # OC14SUK25 |
| 7. Reversing pump seal kit  | part # OC14SUK26 |
| 8. Motor mount assembly kit ( 2 x rubber 'omega' foot)            | part # OC14SUK27 |

**J. ADAPTER FITTINGS:**

The reversing pump kits do include adapter fittings to help facilitate integration into the vessel's hydraulic plumbing. Each kit includes the following:

- Qty 3 x QC17237 Adapter-Plug, ORB-05M
- Qty 3 x OC17235 Adapter-Straight, ORB-05M x 3/8 Tube Compression w/o nut\*
- Qty 3 x OC17262 Adapter-Straight, ORB-05M x 1/4 NPT Female\*\*

\* Nuts not included because it is expected that hoses are used instead of hard tubing.

\*\* Optional adapter for those who wish to use NPT