

Customer To Purchase And Add Recommended Lubricant And Fluid To Couplings
Rec Ounces: 1137
Fill Angle: 84.0
Fluid Type: Standard
Fire Resistant

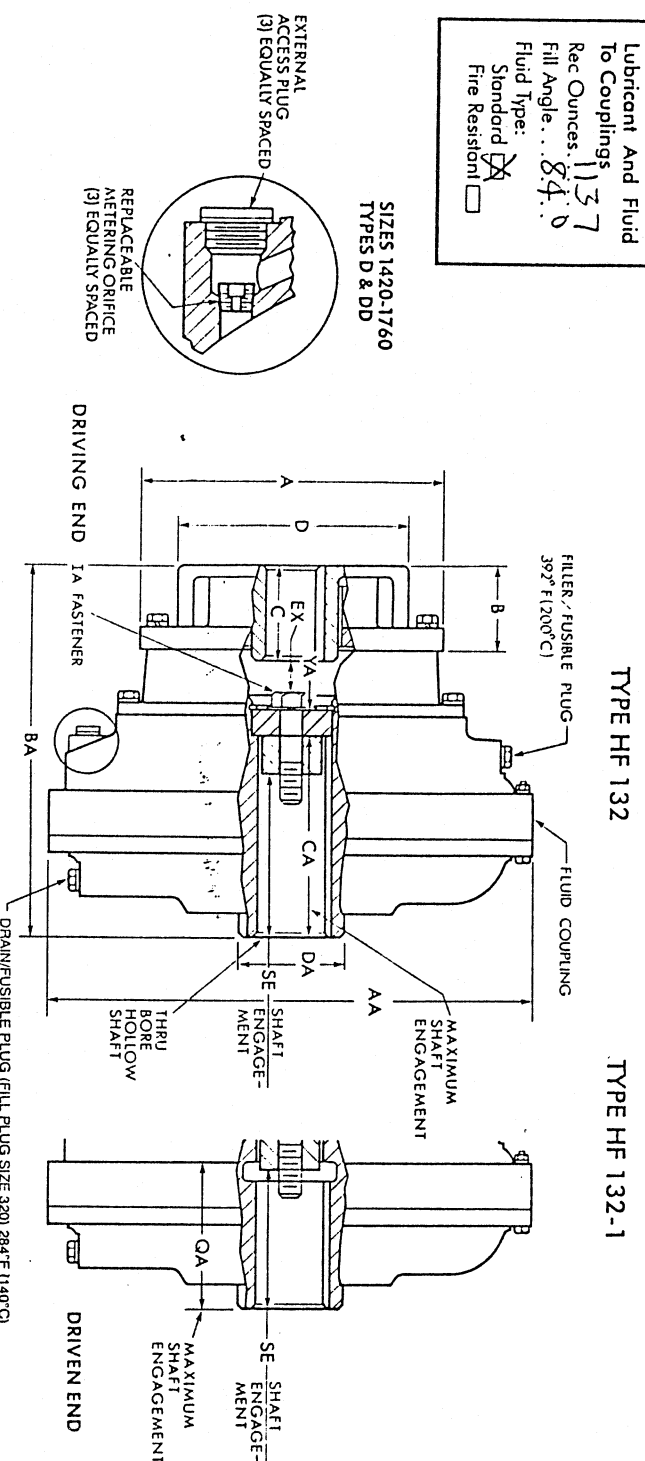

Max. or Thru-Bore Shaft Output with Keeper Plate
See Reverse Side for Balance of Dimensions and Footnotes
TYPE HF 132
TYPE HF 132-1

MOTOR HUB BORE EXH. ADDED.
T. WALTER 11-19-2000

400 FIBERGLASS DRUM

PLUG SIZE *	Cplg Wt. No Bore W/O Fluid-lb	Allow. Speed rpm	Dimensions - Inches												
			A	B	C	D	AA	HFD HFN HFR	BA HFD HFN HFR	CA	DA	IA Fastener Size	EX HFD HFN HFR	SE (Min)	YA
270HF	47	1800	7.44	2.17	1.51	5.71	12.40	7.52	2.94	5/8-11 UNC	0.10	N/A	3.00	0.75	3.45
320HF	73	1800	8.66	2.36	1.97	6.69	14.37	8.58	3.13	5/8-11 UNC	0.11	3.20	0.75	4.12	
370HF	112	1800	9.92	2.56	3.11	7.87	16.73	11.41	3.52	7/8-10 UNC	0.13	3.80	0.75	4.35	
1420HF	158	1800	11.47	2.76	3.54	9.06	18.70	15.99	7.26	7/8-9 UNC	0.28	4.40	1.00	4.60	
1480HF	230	1800	13.19	3.35	4.33	10.24	21.65	18.48	8.00	1-8 UNC	0.80	4.22	5.00	5.50	
1584HF	392	1800	15.16	3.94	5.12	11.81	26.38	20.87	9.23	1-8 UNC	0.81	4.00	5.80	6.50	
1660HF	613	1800	17.91	4.84	5.00	14.17	29.92	20.00	11.54	1 1/4-7 UNC	1.19	5.92	6.50	7.79	
1760HF	828	1500	20.24	4.92	5.00	14.17	34.75	22.45	13.64	1 1/4-7 UNC	1.41	6.25	7.20	9.14	
870HF	1252	1500	23.43	4.92	7.09	15.75	38.98	24.61	14.82	1 1/4-7 UNC	0.30	5.89	8.00	10.42	

PRINT OF FALK COUPLING FOR: AHLSTROM MACHINERY
Overhang This Hub: 3.4975
Overhang This Hub: 4.4993
SE (Actual): 6.50

CERTIFIED
DRAWN: [Signature]
CHECKED: [Signature]
DRAWING NO. 525-358 D
DATE 8-1-00
NO. REQD. Z
FOR UNIT ON M.O. 00.067907.01
PO. Ref 69-49.282
COUPLING M.O. 067907.02
MOTOR MFG. MOTOR HP 700 RPM 1770
LOAD HORSEPOWER REQUIRED
COUPLING INPUT RPM 1735
START FACTOR 4.090

Customer To Purchase And Add Recommended Lubricant And Fluid To Couplings
Rec Ounces: 1137
Fill Angle: 84.0
Fluid Type: Standard
Fire Resistant

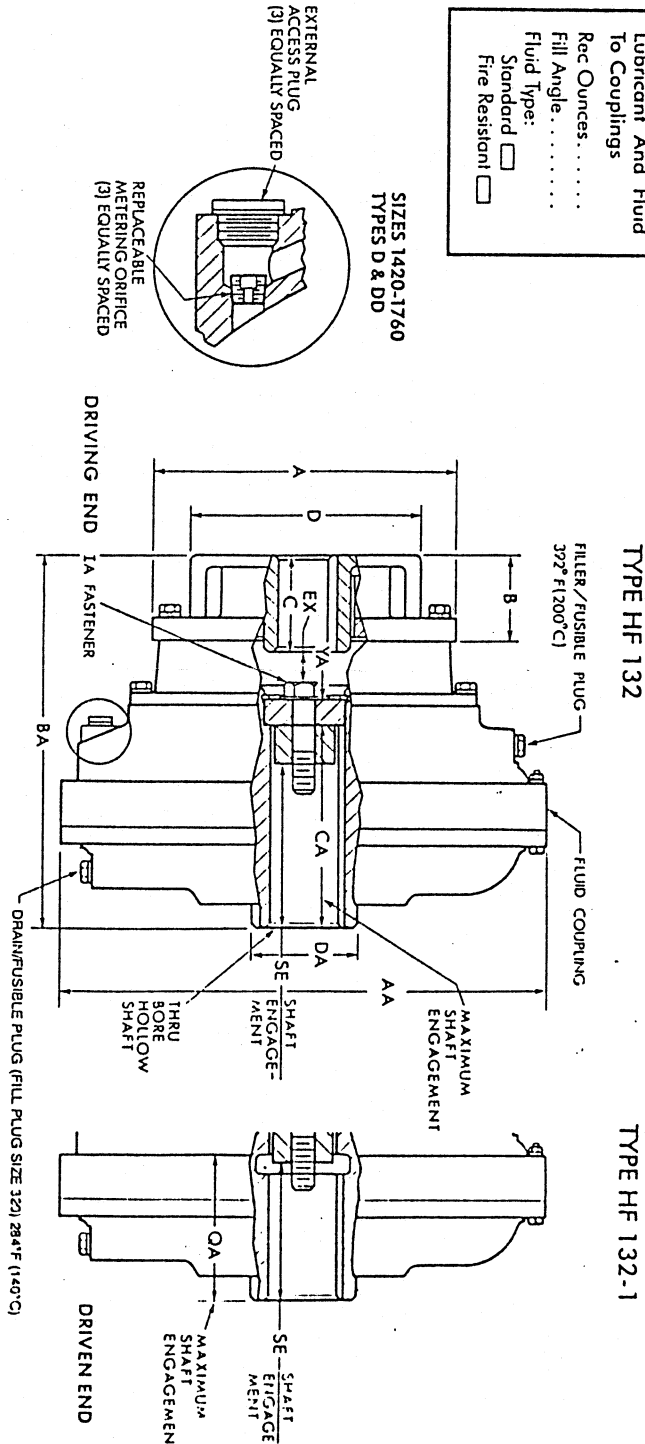

TYPE HF 132
TYPE HF 132-1

PLUG SIZE *	Tschan Cplg. †				Input		Output		Fluid @ Max Fill	
	Size	Sq. Key	Type 132 Sq. Key	Hollow Shaft * Type 132-1 Sq. Key	HFD * HFN HFR	HFD * HFN HFR	HFN * HFR	HFD	HFD *	
270HF	145	1.62	1.750	2.175	444 *	N/A	72	103 *	N/A	
320HF	170	2.25	2.250	2.500	973 *	N/A	143	191 *	N/A	
370HF	200	2.38	2.250	2.500	1,811	N/A	283	393	N/A	
1420HF	230	2.50	2.500	3.000	2,802	3,022	570	820	975	
1480HF	300	3.38	3,020	3,375	5,278	5,608	1,260	1,504	1,950	
1584HF	300	3.75	3,520	4,000	11,448	12,293	1,903	3,844	4,955	
1660HF	360	5.12	4,990	4,500	21,186	22,990	5,076	9,225	12,240	
1760HF	360	4.75	4,750	N/A	38,614	39,938	4,660	16,320	15,240	
870HF	400	5.75	5,250	N/A	89,304	80,871	19,642	39,300	41,000	

Maximum Bore
WR² (lb-in²) *
Fluid @ Max Fill
HFD * HFN HFR
HFD * HFN HFR
HFN * HFR
HFD

CERTIFIED
RECORD PRINT
NOV 21 2000
PURCHASER

Max. or Thru-Bore Shaft Output with Keeper Plate

See Reverse Side for Balance of Dimensions and Footnotes

TYPE HF 132 TYPE HF 132-1

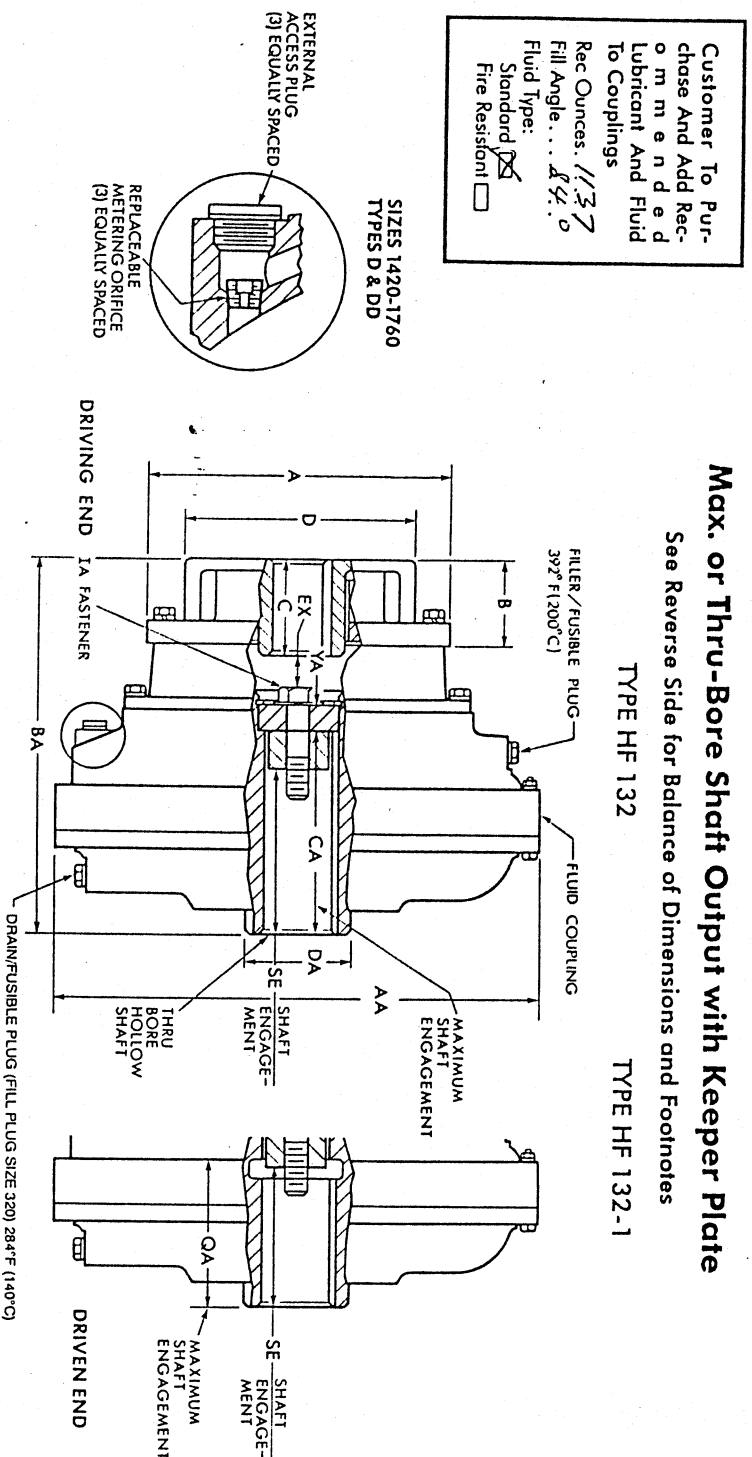

Customer To Purchase And Add Recommended Lubricant And Fluid To Couplings
Rec Ounces: 1137
Fill Angle: 44°
Fluid Type: Standard
Fire Resistant:

SIZES 1420-1760
TYPES D & DD

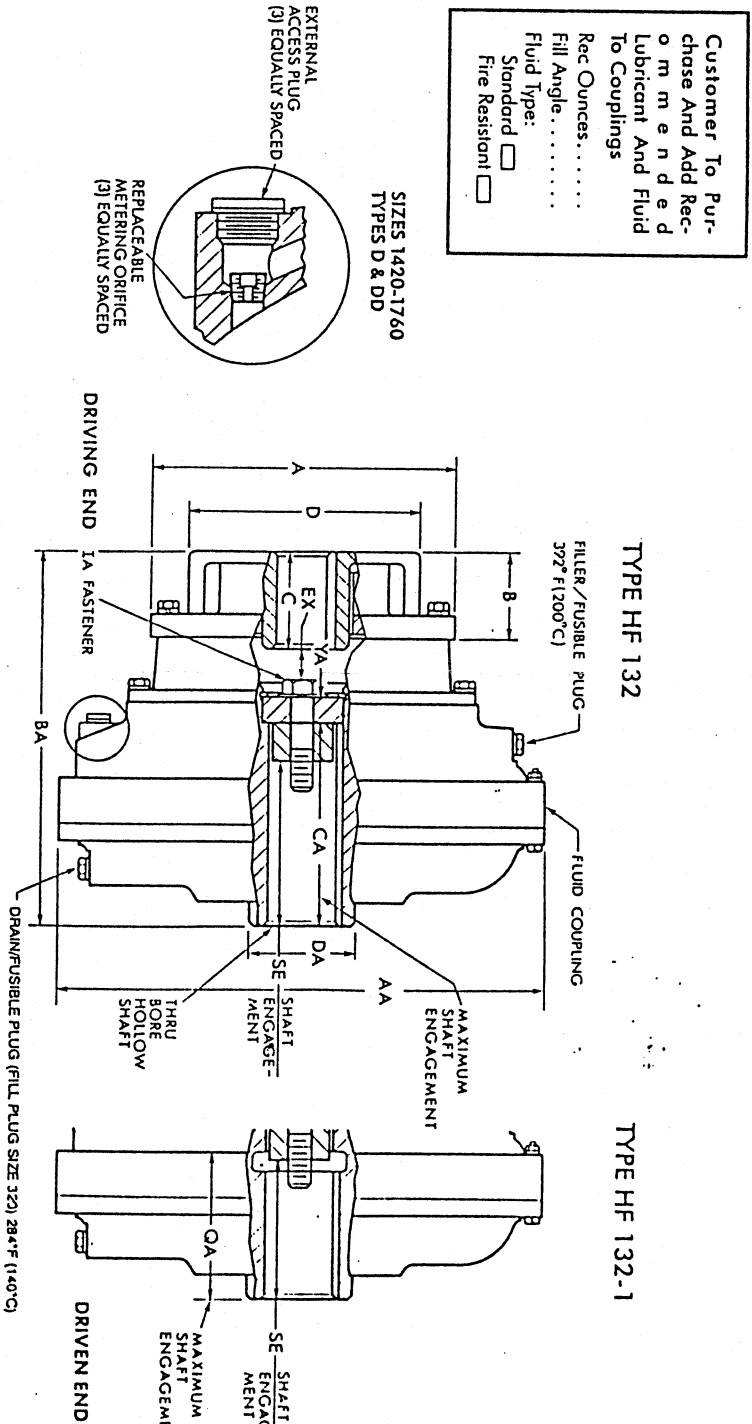

Customer To Purchase And Add Recommended Lubricant And Fluid To Couplings
Rec Ounces: 1137
Fill Angle: 44°
Fluid Type: Standard
Fire Resistant:

SIZES 1420-1760
TYPES D & DD

FIGURE LOW DRAW

FIGURE LOW DRAW

CRIG SIZE *	Cplg Wt. No Bore W/O Fluid-lb		Allow. Speed rpm	Dimensions - Inches														
	HFD HFN HFR	HFD * HFN * HFR *		A	B	C	D	AA	BA	CA	DA	IA	EX	SE	YA	QA		
270HF	47	N/A	1800	7.64	2.17	1.651	5.71	12.40	7.52	N/A	4.45	2.94	5/8-11UNC	0.10	N/A	3.00	0.75	3.45
320HF	73	N/A	1800	8.66	2.36	1.971	6.69	14.37	8.58	N/A	5.18	3.13	5/8-11UNC	0.11	N/A	3.20	0.75	4.12
370HF	112	N/A	1800	9.92	2.56	2.311	7.87	16.73	11.41	N/A	6.74	3.52	5/8-10UNC	0.13	N/A	3.80	0.75	4.35
1420HF	158	167	1800	11.42	2.76	3.54	9.06	18.70	12.88	12.88	7.26	4.12	7/8-9UNC	0.28	3.39	4.40	1.00	4.60
1480HF	230	243	1800	13.19	3.35	4.33	10.24	21.65	15.06	15.06	8.00	4.71	7/8-9UNC	0.80	4.22	5.00	1.12	5.50
1584HF	382	414	1800	15.16	3.74	5.12	11.81	24.38	18.48	18.48	8.00	5.49	1-8UNC	0.18	4.00	5.80	1.12	6.50
1660HF	613	642	1800	17.91	4.84	5.001	14.17	29.92	20.00	24.33	11.54	6.28	1 1/4-7UNC	1.19	5.52	6.50	1.12	7.79
1760HF	829	871	1500	20.24	4.82	5.001	14.17	34.25	22.45	22.29	13.64	6.68	1 1/4-7UNC	1.41	6.25	7.20	1.35	9.14
870HF	1252	1325	1500	23.43	4.92	7.09	15.75	38.98	24.61	30.20	14.82	7.46	1 1/4-7UNC	0.30	5.89	8.00	1.25	10.42

FLUID SIZE & TYPE	TSCHAN CRIG SIZE & TYPE	DRIVING HUB				DRIVEN-MAX. or THRU BORE SHAFT				Between Shaft Ends
		Bore	Keyway	Fitted To	Fitted By	Bore	Keyway	Fitted To	Fitted By	
1660HF	360	3.4975	7/8 x 7/16	MTR	RUR	4.4993	1 x 1/2	HSS	RAU	20.0
132-1		3.4985				4.5008				

PRINT OF FALK COUPLING FOR... A.H.L.S.T.R.O.M. M.A.C.H.I.N.E.R.Y.

DATE	8-11-00	MOTOR MFG.	FRAME SIZE
NO. REQ'D.	2	MOTOR HP	700 RPM
FOR UNIT ON M.O.	02-067908-01	LOAD HORSEPOWER REQUIRED	
P.O. REF	069-69-282	COUPLING INPUT RPM	1735
COUPLING M.O.	00-067968-02	START FACTOR	1.4090

Dimensions • HF132 & 132-1 Fluid Couplings with Tschan Coupling Input

See Reverse Side for Balance of Dimensions and Footnotes

TYPE HF 132 TYPE HF 132-1

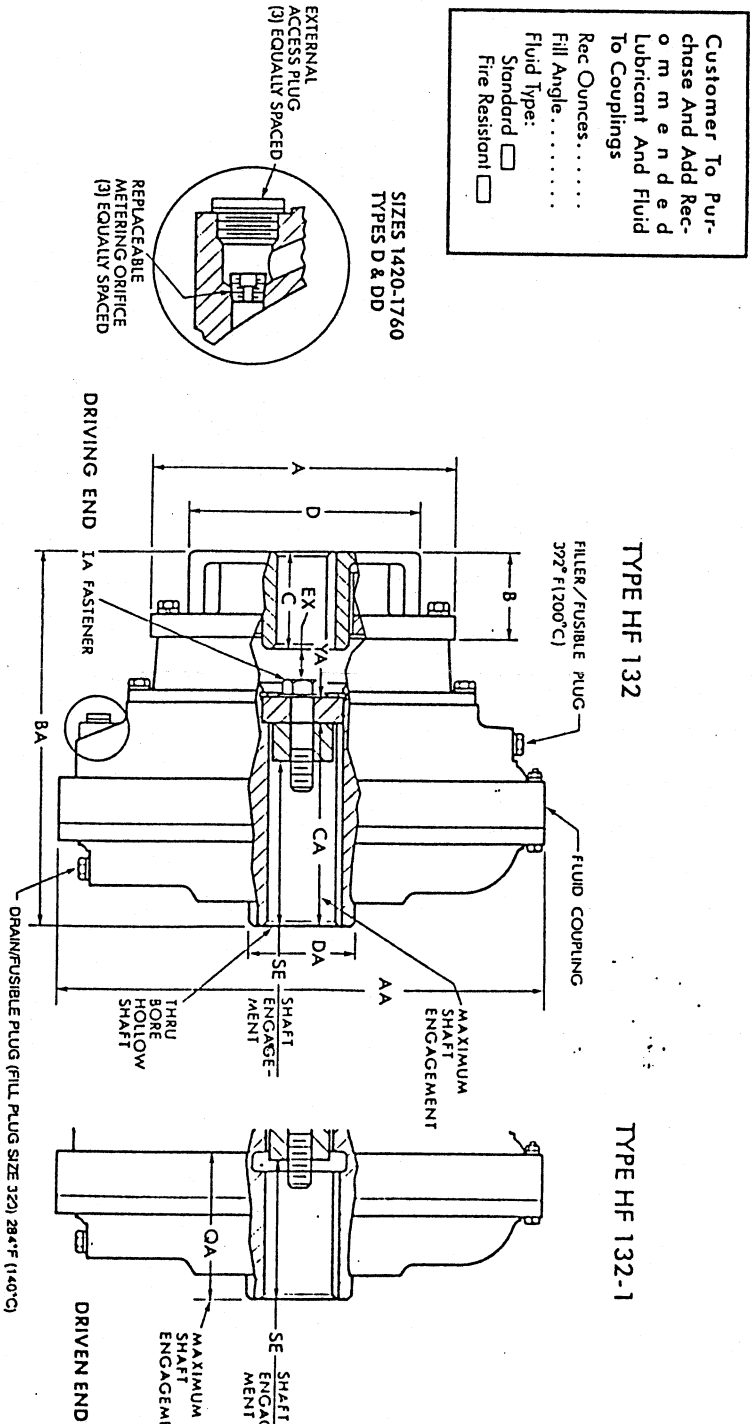

Customer To Purchase And Add Recommended Lubricant And Fluid To Couplings
Rec Ounces: 1137
Fill Angle: 44°
Fluid Type: Standard
Fire Resistant:

SIZES 1420-1760
TYPES D & DD

FIGURE LOW DRAW

CRIG SIZE *	Tschan Cplg. †				Input		Output		Fluid @ Max Fill	
	Size	Sq. Key	Type 132	Type 132-1	HFD * HFN HFR	HFD * HFN HFR *	HFD * HFN HFR	HFD * HFN HFR	HFD	HFD *
270HF	145	1.62	1.750	2.125	444 *	N/A	72	103 *	N/A	N/A
320HF	170	2.25	2.250	2.500	973 *	N/A	143	191 *	N/A	N/A
370HF	200	2.38	2.250	2.500	1811	N/A	283	393	478	N/A
1420HF	230	2.50	2.500	3.000	2802	3072	500	820	990	925
1480HF	260	3.38	3.000	3.375	5728	5608	1260	1504	1930	1790
1584HF	300	3.75	3.500	4.000	12448	12423	2500	3544	4555	5175
1660HF	360	5.12	4.750	4.500	21186	21186	5076	7275	9775	11100
1760HF	360	5.12	4.750	4.500	38614	39338	9252	14660	16736	19740
870HF	400	5.75	5.250	N/A	89304	80871	19482	37300	43400	41000

* Sizes 270 and 320 are only available without delay fill chamber (HFN). Sizes 370 and larger are furnished with an active (HFD), inactive (HFR) or enlarged (HFD) delay fill chamber. Consult Factory for other mounting arrangements. Dimensions are for reference only and subject to change without notice unless certified.
† Non-standard shortened Tschan hub length.
‡ Hubs with straight bore are normally furnished with an average interference fit of .0005" per inch of shaft diameter, unless otherwise specified.
§ Size 1420HF is available with a 2.88" bore and a .750" x .125" keyway. Falk will furnish a flat key .750" x .500" x 3.5".
¶ Replace square shaft key with standard rectangular key for use with these bores. CHECK KEY STRESSES.
‡ Values shown for Sizes 270 and 320 are for Type HFN. Sizes 370 and larger are for Types HFD, HFD & HFR. Equivalent mass moment values shown apply only to the fluid coupling (without bore).
* Thru-bore shafts are furnished for modified TRANSITIONAL FIT.

CERTIFIED
RECORD PRINT
MAY 21 2000
PURCHASER

How To Use This Manual

This manual applies to standard Types HF132 & 132-1 couplings. This manual provides detailed instructions on installation, maintenance and parts identification. Use the following Table of Contents to locate required information.

Table Of Contents

General Information Pages 1 & 2
 Installation Pages 2 thru 7
 Maintenance Page 2

CAREFULLY FOLLOW THE INSTRUCTIONS IN THIS MANUAL FOR OPTIMUM PERFORMANCE AND TROUBLE FREE SERVICE.

Introduction

Type HF couplings are designed for horizontal operation. Refer to Factory for coupling operation other than horizontal or for limited end float requirements.

Maximize Performance and Life

The performance and life of couplings depend largely upon how you install and maintain them. Before installing couplings, make certain that foundations of equipment to be connected meet manufacturers' requirements. Check for soft foot. The use of stainless steel shims is recommended. Measuring misalignment and positioning equipment within alignment tolerances is simplified with an alignment computer. These calculations can also be done graphically or mathematically.

It is recommended that final alignment be checked using either an alignment computer or graphical analysis. Both methods allow the incorporation of "cold offsets", which will compensate for shaft position changes due to thermal growth.

WARNING: Lockout power source and remove external loads from unit before servicing unit or accessories.

WARNING: When opening the drain plug, filler plug or orifice seal plug of a warm or hot fluid coupling, place a rag over the plug and loosen the plug slowly to relieve any internal pressure.

WARNING: Consult applicable local and national safety codes for proper guarding of rotating members. Guard must not restrict free flow of air, but the portion of the guard in line with fusible plugs must be solid construction.

CAUTION: DO NOT PAINT fluid coupling. Painting will reduce fluid coupling thermal heat dissipation characteristics.

Identification:

Tschan Coupling — Refer to Figures 6 & 7, Page 3, and Table 4, Page 4.

Fluid Coupling — Size and Type are stamped on coupling perimeter. Refer to Factory for replacement parts.

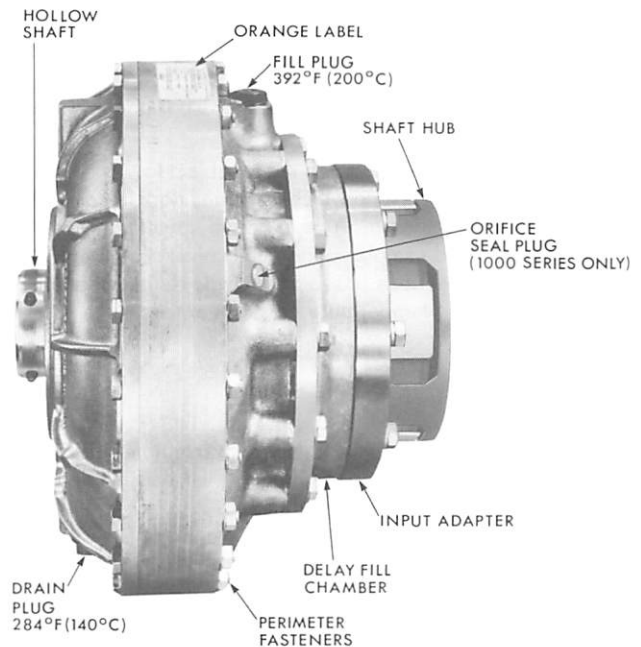

Fluids

The following specifications and fluids listed in Table 1 apply to Falk fluid couplings. Refer to Factory for use of fire resistant fluids. NOTE: Fluids listed are typical products ONLY and should not be construed as exclusive recommendations.

ISO Viscosity Grade — 46

Viscosity at 104°F(40°C) — 46 cSt (215 SSU)

Viscosity Index — 105 or greater.

Pour Point — Must be 5°F(3°C) lower than minimum starting temperature.

Flash Point — 400°F(204°C)

Specific Gravity — 0.87

Antioxidant and Antifoaming Additives

TABLE 1 — Fluids & Operating Temperatures

Manufacturer	Operating Temperature Greater Than:		
	20°F (-7°C)	-20°F (-29°C)	-50°F (-46°C)
Amoco Oil Co.	American Ind. Oil 46	American Ind. Oil 46	...
Exxon Co., USA	Teresstic 46
Gulf Oil Corp.	Harmony 46
Mobil Oil Corp.	DTE Medium	Mobilfluid 423	SHC 624
Shell Oil Co.	Tellus 46
Texaco Inc.	Rando 46	Rando 46	...
Texaco Canada	Regal R&O 46
Union Oil Co. of Calif.	Unax VG 46	Unax VG 46	...

Annual Maintenance

Check shaft coupling alignment on a regular basis. Excessive misalignment will transfer damaging loads to the connected equipment and may cause failure.

Check flexible coupling elastomer spider for wear and replace if necessary.

Check fluid annually or more often if it is subject to overheating. Overheated fluid which becomes dark in color and gives off a burnt odor, must be changed. Fluid suppliers can test coupling fluid samples periodically and recommend economical change periods based on the rate of degradation. Continuous operating temperature must not exceed 212°F(100°C).

Lifting

Remove two perimeter fasteners (metric) approximately 90° apart. Insert threaded rod (Table 3, Page 4) with washers and nuts, then sling coupling as shown in Figure 2.

Figure 2

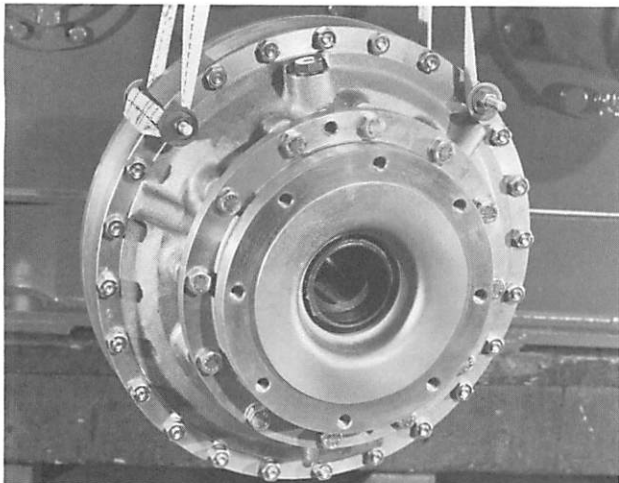

Installation

Only standard mechanics tools, torque wrenches, feeler gauges, straight edges and a bevel protractor with spirit level or Falk Angle Finder are required to install fluid couplings.

1. Install Fluid Coupling.

- a) Lock out starting switch of prime mover.
- b) Check for nicks or burrs on driven shaft and in fluid coupling bore.
- c) Check fit of key in keyways and secure in shaft keyway.
- d) Coat driven shaft with an anti-seize compound.
- e) Installing fluid coupling on driven shaft.
 - 1) These couplings are normally furnished with a slight clearance to light interference fit between coupling hollow shaft bore and driven shaft. A threaded drive rod and drawing on plate are required to draw the coupling onto driven shaft, see Figure 3. Refer to Table 2 for threaded rod and plate dimensions.

CAUTION: DO NOT USE HEAT on fluid coupling shaft. The driven shaft may be cooled with dry ice to reduce its size and assist assembly.

- 2) Screw threaded rod into end of driven shaft.
- 3) Pass fluid coupling over threaded rod and onto driven shaft using the starting overbore area for alignment to driven shaft and keyway.

Figure 3

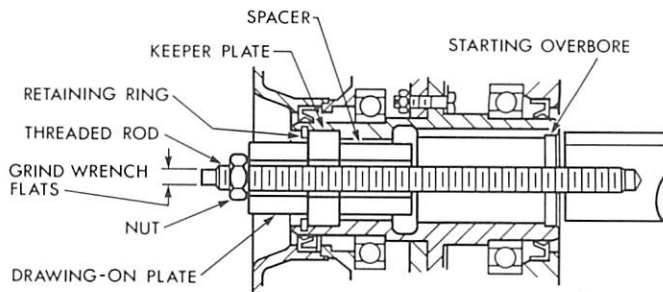

TABLE 2 — Threaded Rod & Drawing On Plate (Dimensions – Inches)

Coupling Size	Threaded Rod ¹ Dia. x Length (Min.)	Drawing On Plate OD (Max.) x ID x Thickness (Min.)
270HF	.625-11 UNC x 11	1.750 x .688 x .750
320HF	.625-11 UNC x 13	2.250 x .688 x 1.500
370HF	.750-10 UNC x 15 (18) ²	2.375 x .875 x 2.000
420HF	.875- 9 UNC x 17 (21) ²	2.625 x 1.000 x 2.000
480HF	.875- 9 UNC x 19 (23) ²	3.125 x 1.000 x 3.000
584HF	1.000- 8 UNC x 21 (25) ²	3.500 x 1.125 x 3.000
660HF	1.250- 7 UNC x 24 (28) ²	4.250 x 1.438 x 3.000
760HF	1.250- 7 UNC x 27 (32) ²	5.250 x 1.438 x 4.000
870HF	1.250- 7 UNC x 30 (35) ²	5.750 x 1.438 x 5.000

¹ SAE Grade 5 (ASTM A449) or equivalent.

² Number in parenthesis is the minimum length required for Type HFDD couplings.

- 4) Assemble spacer, keeper plate and retaining ring (Refer to Table 3, Page 4, for retaining ring number) in hollow shaft of fluid coupling, Figure 3, Page 2. Spacer must be properly seated against keeper plate.
- 5) Place drawing on plate and nut on threaded rod. Make certain drawing on plate is seated against keeper plate and not contacting retaining ring or end of fluid coupling housing.
- 6) Draw fluid coupling onto the driven shaft by tightening nut against drawing on plate. Hold threaded rod end while tightening nut to prevent shaft rotation. Draw coupling on until spacer makes contact with the end of driven shaft.
- 7) Remove threaded rod and drawing on plate. Insert keeper plate fastener with lock washer through keeper plate and spacer, Figures 4 and 5. Carefully thread into tapped hole in driven shaft and tighten to torque specified in Table 3, Page 4.
- g) Reinstall perimeter fasteners and washers. Tighten to torque specified in Table 3, Page 4.

Figure 4 – Type HF132

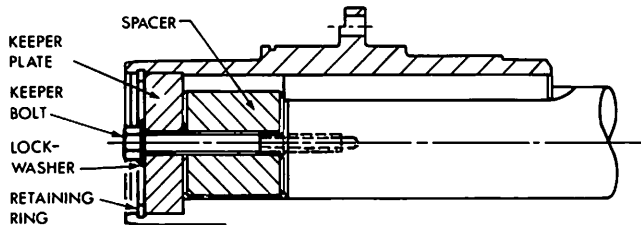
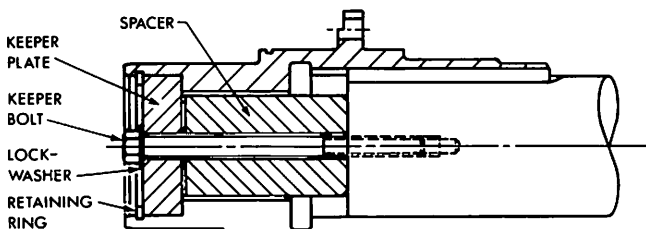

Figure 5 – Type HF132-1



2. Install Adapter and Shaft Coupling.

NOTE: The installation instructions and the method of alignment provided for the shaft coupling are offered as a guide only. It is strongly recommended to consult the flexible coupling manufacturer's installation and maintenance instructions.

- a) Install input adapter (See Figures 6 and 7) to the fluid coupling with lock washers and fasteners provided and tighten to torque specified in Table 3, Page 4. Adapter register must be properly engaged.

Figure 6 — Tschan Type SV

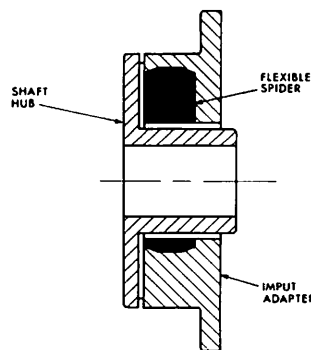
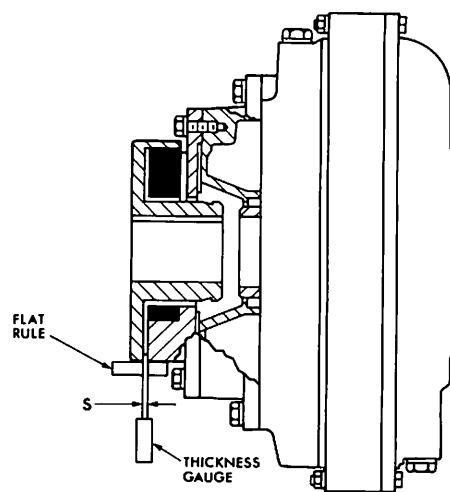

Figure 7



- b) Assemble shaft hub (Figure 6) to motor shaft as instructed in coupling manufacturer's manual.
- c) Insert flexible spider (Figure 6) into Tschan coupling.
- d) Position the motor with shaft hub close to the fluid coupling in approximately the correct position. Engage motor and shaft hub axially into input adapter of fluid coupling & elastomer spider of flexible coupling. For precise motor alignment, the use of adjustment screws with brackets attached to the bedplate (See Figure 8) is recommended.

Figure 8

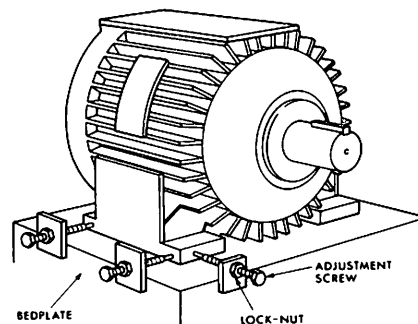

TABLE 3 — Fastener Size And Tightening Torques

Coupling Size	Perimeter Fasteners(Grade 8.8)		Input Adapter Fasteners(Grade 8.8)		Keeper Plate Fasteners(SAE Grade 5)		Retaining Ring No. ¹	Threaded Rod for Lifting Dia.-in.
	Size x Lgth(mm)	Torque lb.-ft.	Size x Lgth(mm)	Torque lb.-ft.	Size-in.	Torque lb.-ft.		
270HF	M8 x 65	15	M8 x 35	15.0	.625-11	60.0	RRN200	.250
320HF	M8 x 65	15	M12 x 40	59.0	.625-11	60.0	RRN275	.250
370HF	M10 x 80	33	M12 x 45	59.0	.750-10	110.0	RRN275	.375
420HF	M10 x 80	33	M12 x 45	59.0	.875- 9	120.0	RRN312	.375
480HF	M10 x 80	33	M12 x 50	59.0	.875- 9	120.0	RRN362	.375
584HF	M14 x 100	88	M12 x 55	59.0	1.000- 8	180.0	RRN412	.500
660HF	M14 x 120	88	M14 x 65	88.0	1.250- 7	250.0	RRN475	.500
760HF	M16 x 150	140	M16 x 60	140.0	1.250- 7	250.0	RRN575	.625
870HF	M20 x 180	279	M20 x 75	245.0	1.250- 7	250.0	RRN650	.750

¹ Ramsey Spir O Lox® RRN Series or equivalent.

- e) The two halves of the Tschan coupling must be parallel within .004". To accomplish this, align so that a straight edge rests squarely on both halves as shown in Figure 7, Page 3, and also at 90° intervals. Check with feelers.
- f) While remaining parallel, the two half-couplings must be checked for angular misalignment. Initially position the coupling halves using a gauge equal in thickness to the "S" dimension specified in Table 4. Next, measure the clearance between the two flanges at 90° intervals. Compare with the values listed under "S-Range" in Table 4. The space between the flanges must be within this range and must not vary by more than .008" TIR.
- g) Tighten all foundation fasteners and repeat Steps e and f. Re-align coupling if necessary.

4. Check Fill Angle.

- a) Refer to fluid fill label described in Step 3b for required fill angle.
- b) Use a Falk Angle Finder or a bevel protractor with spirit level set for the required fill angle, and place it on flat boss of filler hole as shown in Figure 9.

Figure 9

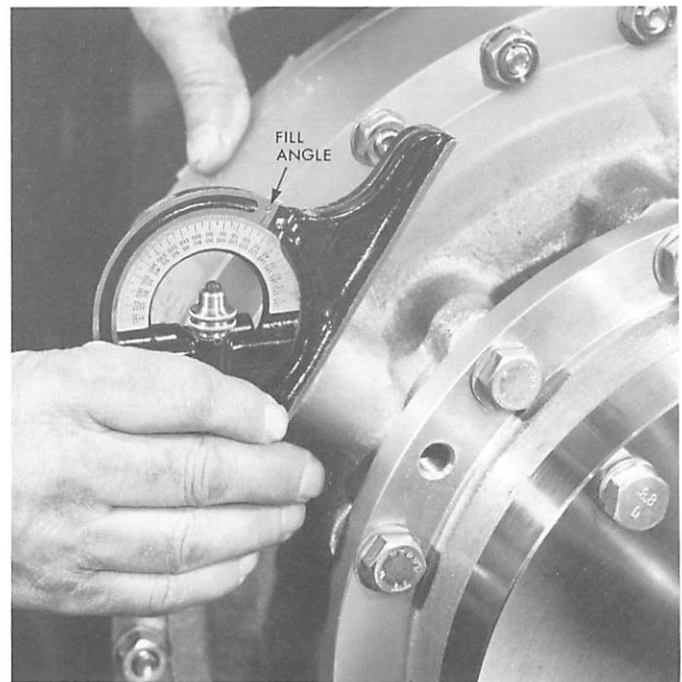

TABLE 4 — Gauge Thickness – Inches

Fluid Cplg Size	Tschan Cplg Size	S	S - Range
270	SV145	.08	.08-.12
320	SV170	.10	.10-.16
370	SV200	.10	.10-.16
420	SV230	.18	.18-.24
480	SV260	.18	.18-.24
584	SV300	.18	.18-.22
660	SV360	.18	.18-.24
760	SV360	.18	.18-.24
870	SV400	.30	.30-.36

3. Fill Fluid Coupling.

- a) Rotate fluid coupling until fill plug is on top and remove it, (Both fill and drain plugs have metric threads.) fill plug is on the input adapter (Tschan coupling) side of coupling, (Figure 1, Page 1) except for Size 320, where the plug location is on the opposite side.
- b) Install the required amount of fluid shown on the orange label on fluid coupling perimeter. Fluid must meet the specifications listed in Table 1, Page 1. Do not remove fluid fill label, refer to Factory if label is missing.
- c) Before reinstalling fill plug, check fill angle as described in the following step.

- c) Slowly rotate fluid coupling until the required fill angle is achieved, Figure 10. Fluid must appear at the lip of the hole. Add or drain fluid until level is correct. Figure 11 shows fill angle range.
- d) Reinstall fill plug with seal ring and tighten to required torque; Sizes 185-270, 22 lb-ft.; Sizes 320-660, 33 lb-ft.; Sizes 760 and 870, 59 lb-ft.

Figure 10

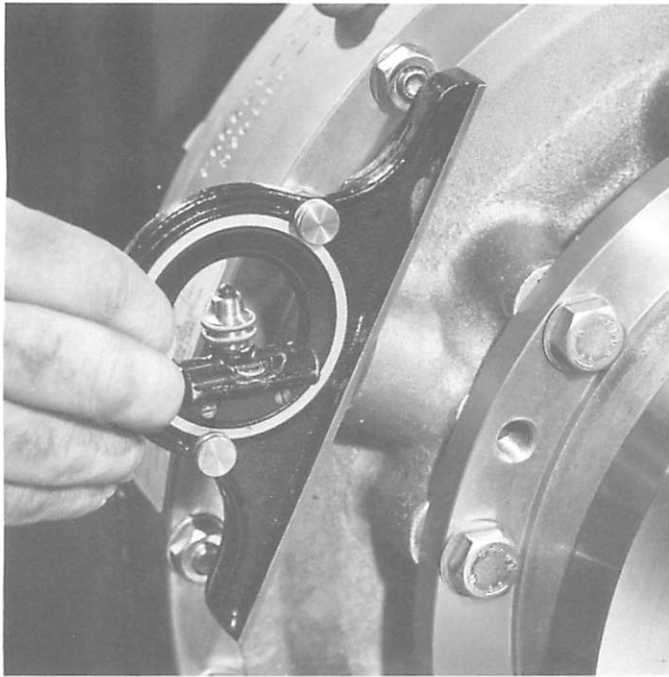
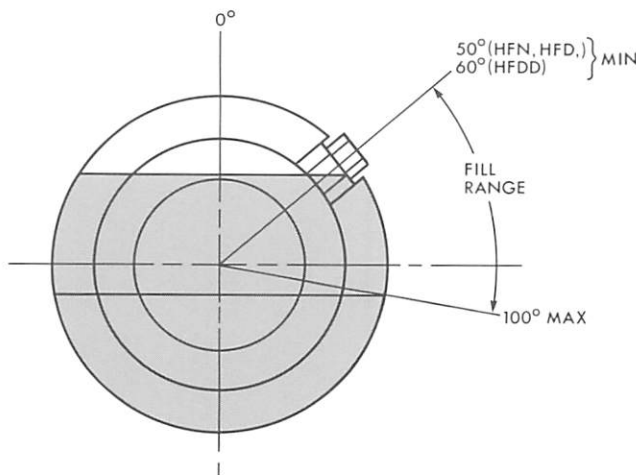

Figure 11



5. 1000 Series Couplings.

The 1000 Series fluid couplings contain 3 orifice plugs (metric threaded) located near the outer part of the casing. They are located behind three metric hex socket seal plugs (see Figure 12). The function of these orifice plugs is to meter the fluid exiting from the delay fill chamber into the working circuit of the fluid coupling. These plugs are initially drilled with a 2.5mm hole (Sizes 1420-1660HF) and 3.5mm on the Size 1760HF, which results in acceptable starting times for most applications. Should your application require increased or reduced starting times, refer to Table 5 below for other orifice hole sizes and their estimated affect on starting time. These estimates are based on the change in flow rate for the fluid to exit the delay fill chamber.

CAUTION: Increasing the starting time can result in overheating the fluid coupling and blowing the fusible plugs. Refer to Table 6 for orifice and seal plug sizes & required hex "Allen" wrench sizes.

Figure 12

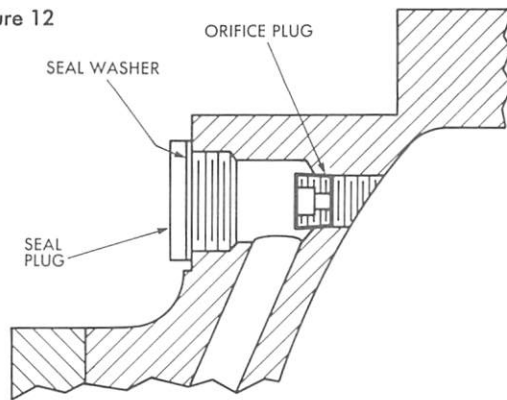

TABLE 5 — Fluid Coupling Starting Times

Orifice Hole Diameter	Estimated Starting Time - % of Original	
	1420HF - 1660HF	1760HF
3/64" (0.0469)	440	860
1/16" (0.0625)	250	490
5/64" (0.0781)	160	310
3/32" (0.0937)	110	220
2.5 mm (0.0984)	100	200
7/64" (0.1094)	80	160
1/8" (0.1250)	60	120
3.5 mm (0.1380)	50	100
5/32" (0.1562)	40	80
3/16" (0.1875)	30	50

TABLE 6 — Orifice and Seal Plug Sizes

Cplg Size	Orifice Plug DIN906		Seal Plug DIN908		Seal Washer DIN 7603 Type "A" Copper
	Thread Size	Hex Key Size	Thread Size	Hex Key Size	
1420	1/8R BSPT	5 mm	18 x 1.5 mm	10 mm	18 x 22 x 1.5 mm
1480	1/4R BSPT	6 mm	18 x 1.5 mm	10 mm	18 x 22 x 1.5 mm
1584	3/8R BSPT	8 mm	22 x 1.5 mm	12 mm	22 x 27 x 1.5 mm
1660	3/8R BSPT	8 mm	22 x 1.5 mm	12 mm	22 x 27 x 1.5 mm
1760	1/2R BSPT	10 mm	27 x 2.0 mm	17 mm	27 x 32 x 2.0 mm

6. Fusible Plugs.

- a) Fusible plugs in the fill and drain holes have solder cores that melt at the temperatures shown in Figure 1, Page 1. One extra 284°F (140°C) plug is furnished with each coupling.
- b) If solder in fusible plug melts due to overheating from stalling or overloading, refer to Table 7, Page 7, and correct the cause of overheating.

CAUTION: DO NOT replace fusible plugs with solid plugs. Use of solid plugs can result in coupling failure from overheating unless used in conjunction with a thermal trip switch. Refer to Factory for thermal trip switch feature.

- c) Replace fusible plugs as instructed in Step 4d.
- d) Refill coupling with clean fluid as instructed in Steps 3 and 4, Pages 4 & 5.

Coupling Removal

1. Type 132 & 132-1:

- a) Support coupling with sling as shown in Figure 2, Page 2.
- b) Remove input adapter.
- c) Remove keeper bolt, lock washer, retaining ring, and keeper plate.
- d) Insert threaded removal plate and Spir O Lox® ring into hollow shaft bore.
- e) Coat threads of hydraulic removal cylinder with oil. Thread cylinder into removal plate until snug.
- f) Connect Enerpac pump (or equal) to cylinder and pump until fluid coupling is free from shaft. (Refer to Figure 13 for removal set up.) If the cylinder rod is not long enough to completely remove coupling, it will be necessary to position a spacer block between the rod and the shaft.

Figure 13

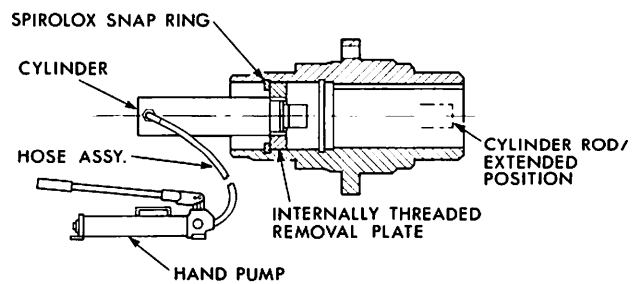

TABLE 7 — Startup And Trouble Shooting

Problem	Possible Cause	Solution
Driven shaft fails to reach specified speed.	Drive motor defective or incorrectly connected.	Check motor connection, speed, amperage draw and power draw.
	Driven machine jammed.	Check driven machine and remove jam.
	Power consumption exceeds coupling capacity at specified fill angle.	1
	Coupling over or under filled.	Re-check fill angle per Step 4, Page 4.
	Coupling leaking.	Correct source of leakage and re-check fill angle per Step 4, Page 4.
	1000 Series - Orifice plug hole plugged.	Clean orifice plug hole or use larger hole.
Fusible plugs melt.	Coupling under filled.	Re-check fill angle per Step 4, Page 4.
	1000 Series - Orifice plug hole too small or plugged.	Enlarge orifice hole size (See Table 5 for estimated start time reduction) or clean plugged holes.
	Coupling leaking.	Correct source of leakage and re-check fill angle per Step 4, Page 4.
	Driven machine jammed.	Check driven machine and remove jam.
	Power consumption exceeds coupling capacity of specified fill angle.	1
Coupling vibration exceeds acceptable limits.	Incorrect shaft coupling alignment.	Re-align per instructions in shaft coupling service manual.
	Incorrect shaft coupling alignment due to thermal growth.	Check "HOT" alignment and adjust to compensate for thermal growth.
	Worn shaft coupling parts.	Correct cause of wear and replace worn parts.
	Loose foundation, shaft coupling or adapter fasteners.	Check and tighten fasteners accordingly.
	Damaged fluid coupling bearing.	Return fluid coupling to Factory for bearing replacement.

¹ Increase fluid fill by decreasing fill angle in 5° increments to a minimum of 50°. If drive shaft still does not reach specified speed, consult the Factory.

TABLE 8 — Drive Data Records

Equipment Identification
Motor/Brake Hp	@ Input RPM
Fluid Coupling Size
Fill Angle	Degrees. Fill Volume Fl. Oz.
Falk Master Order Number	Date Installed