

PLAN VIEW
1:8

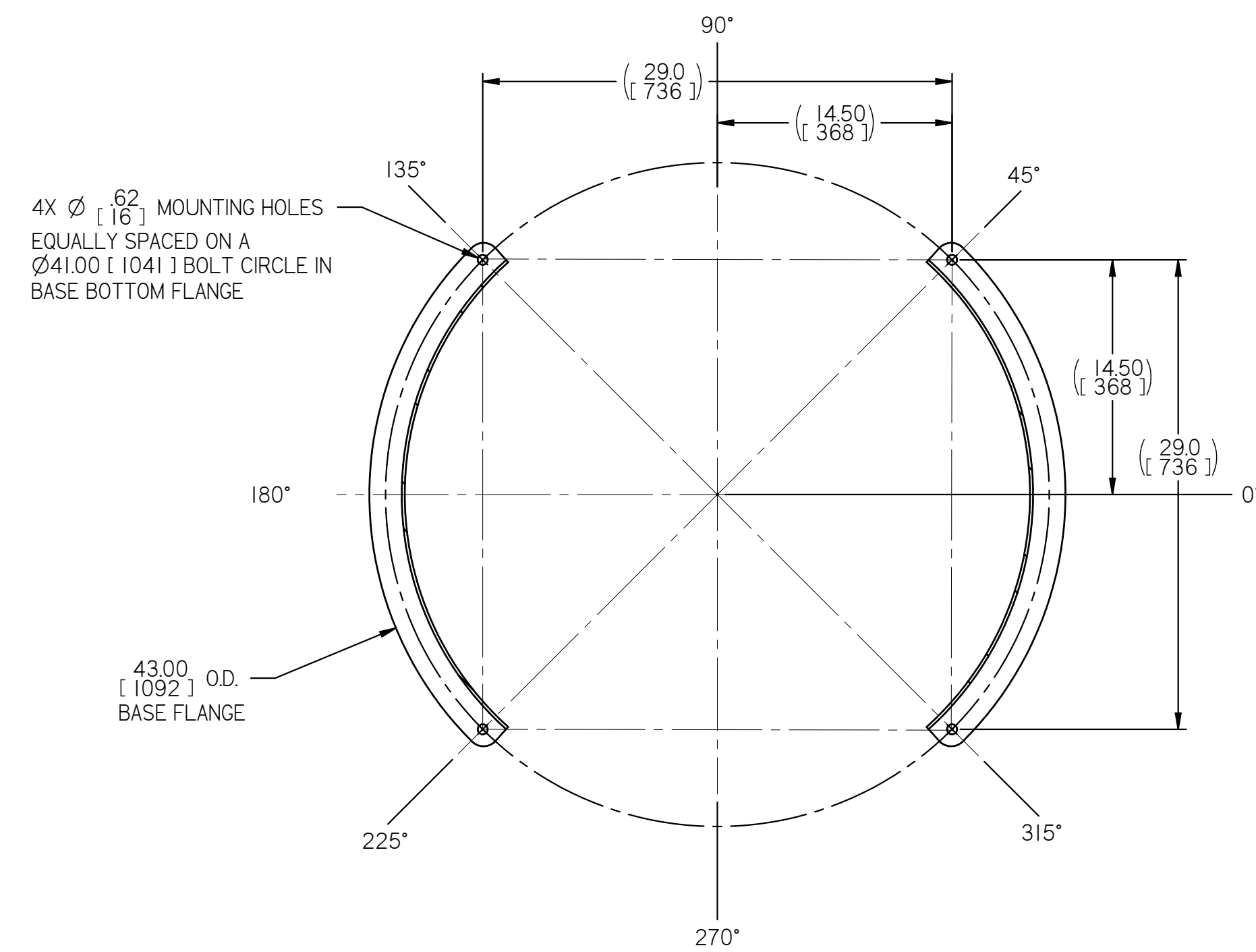

UNIT MOUNTING DETAILS
1:8

- NOTES:
- SEE PLAN VIEW FOR ACTUAL ORIENTATION.
 - FRAME DISCHARGE SPOUTS MAY BE ORIENTED TO SUIT INSTALLATION CONDITIONS, BUT SHOULD MAINTAIN BALANCE FOR OPTIMUM SCREENING.
 - ALL FRAMES AND COVER ARE TO BE MADE OF 304 STAINLESS STEEL AND HAVE A GLASS BEAD FINISH.
 - BASIC DRIVE ASSEMBLY TO BE MADE OF CARBON STEEL AND PAINTED WHITE.
 - ALL DIMENSIONS IN [] BRACKETS ARE IN MILLIMETERS.
 - ITEM #16 THRU #19 NOT SHOWN.

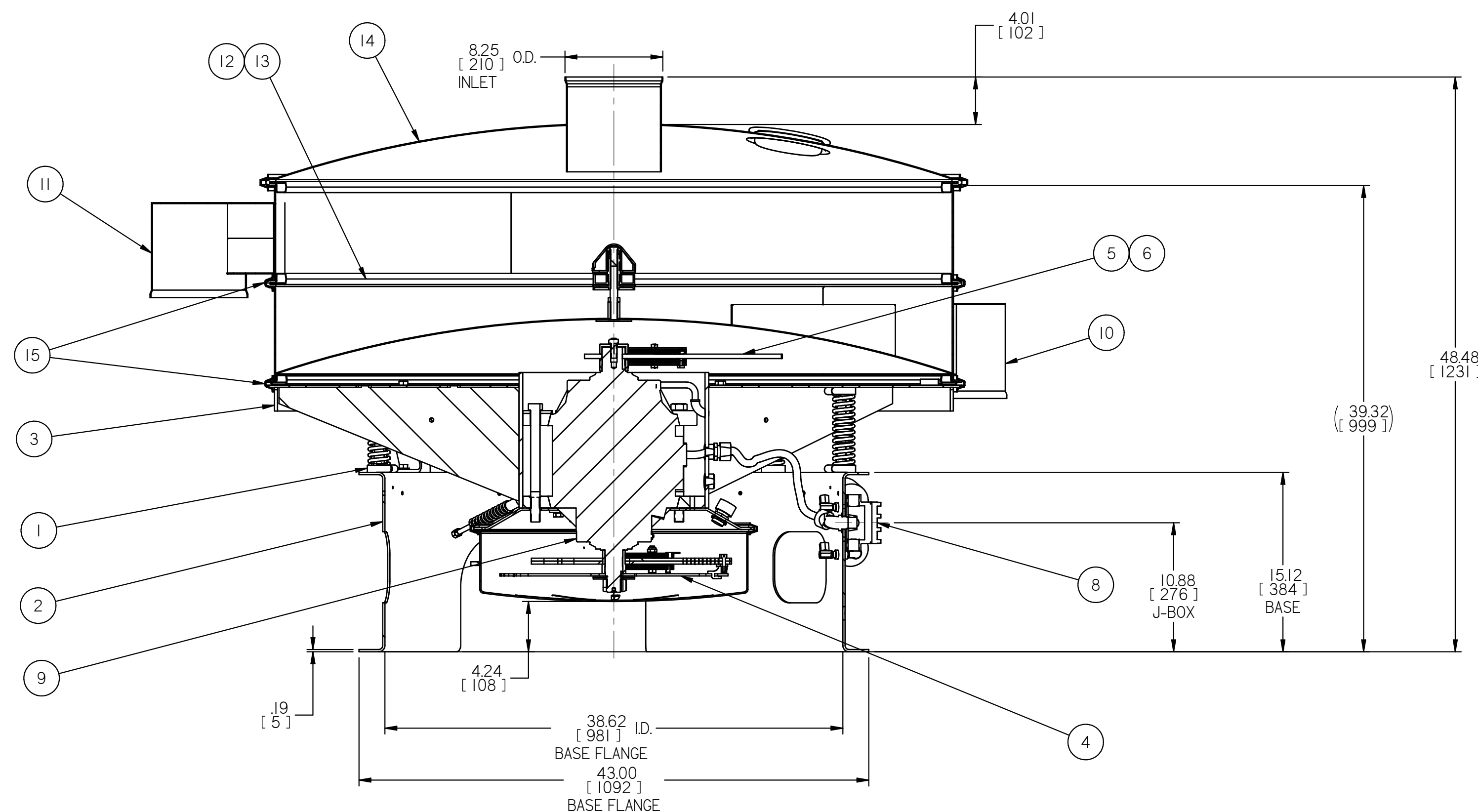

SECTION A-A
1:8

ITEM	PART NUMBER	TITLE	QTY
1	H60C70000-00AD	BASIC DRIVE ASSEMBLY 2.5HP, HLX	1
2	H60C70100-00AD	BASE WELDMENT, 15.125" [384.2] TALL, HLX	1
3	H60C70400-00AD	LOWER TABLE WELDMENT, HLX	1
4	H60S01750-00AB	BOTTOM WEIGHT ASSEMBLY, 48-60, 1200 RPM, HLX	1
5	H60S01700-00AB	TOP WEIGHT ASSEMBLY, 48-60, 1200 RPM, HLX	1
6	H48S01710-00	TOP WEIGHT SPACER SWECO, HLX	1
7	H60K25044-F1	TECHLUBE KIT, (2) 4 OZ. GREASE CARTRIDGES, HLX	1
8	H60K19025-00	J-BOX ASSEMBLY, STANDARD, HLX	1
9	E02C4805IN	MOTION GENERATOR 2-1/2 HP, 1200 RPM, 460 V, 60 HZ, 3 PHASE T.E.N.V.	1
10	S60S82950-00AB	8" [203] TABLE FRAME ASSEMBLY WITH 6" X 8" [152 X 203] SPOUT	1
11	S60S80800-00AB	8" [203] SPACING FRAME WELDMENT WITH 6" X 8" [152 X 203] SPOUT	1
12	S60W1102	THIN LIP CHANNEL GASKET, WHITE TPE FDA	1
13	S60S11085	THIN LIP TENSION RING 18 GA.	1
14	G60S81400-00AB	DOMED COVER ASSEMBLY WITH 8" [203] INLET AND 6" [152] RADIUS INSPECTION OPENING	1
15	S60S81150	Ø 58.75" [1492] CLAMP RING ASSEMBLY, HEAVY DUTY	2
16	S18S01961	SEPARATOR UNIT TAG	1
17	I03290629	HL 48, 60, 72 ROUND SEPARATOR FIELD INSTALLATION AND OPERATIONS MANUAL	1
18	S60K02000	SHIPPING KIT FOR 60" [1524] UNIT	1
19	I03295002	F.A.T. PROCEDURES AND RECORDS FOR ROUND SEPARATOR UNITS	1

SALES DRAWING ONLY
UNLESS OTHERWISE SPECIFIED, ALL DIMENSIONS, SPECIFICATIONS, WEIGHTS, ETC. ARE APPROXIMATE AND SUBJECT TO CHANGE WITHOUT NOTICE PRIOR TO CERTIFICATION.

CUSTOMER PROJECT NO. XX.

CUSTOMER PROJECT NO. -

P.O. No. XXXX

S.O. No. XXXX DATE 1/16/2020

DRAWN BY YJain

UNIT WEIGHT (EMPTY) 1056 LBS. APPROX.

UNIT 60" SWECO ROUND SEPARATOR

MODEL: HX60_88TLWC

DRAWING NO. HX60_88WC REVISION -

THIS PRINT IS THE PROPERTY OF SWECO, BUSINESS UNIT OF M-I, L.L.C. 8029 U.S. HIGHWAY 25 FLORENCE, KY 41022
THE INFORMATION DISCLOSED HEREIN INCLUDES PROPRIETARY RIGHTS OF SWECO, DIVISION OF M-I, L.L.C. NEITHER THIS DOCUMENT NOR THE INFORMATION DISCLOSED HEREIN SHALL BE REPRODUCED OR TRANSFERRED TO OTHER DOCUMENTS OR USED OR DISCLOSED TO OTHERS FOR MANUFACTURING PURPOSES, OR FOR ANY OTHER PURPOSES, EXCEPT AS SPECIFICALLY AUTHORIZED IN WRITING BY SWECO, BUSINESS UNIT OF M-I, L.L.C. IF THIS PRINT IS SUPPLIED IN CONNECTION WITH THE SALE OR DELIVERY OF SWECO EQUIPMENT, IT IS TO BE USED SOLELY FOR MAINTENANCE, REPAIR OR INSTALLATION OF SUCH EQUIPMENT.

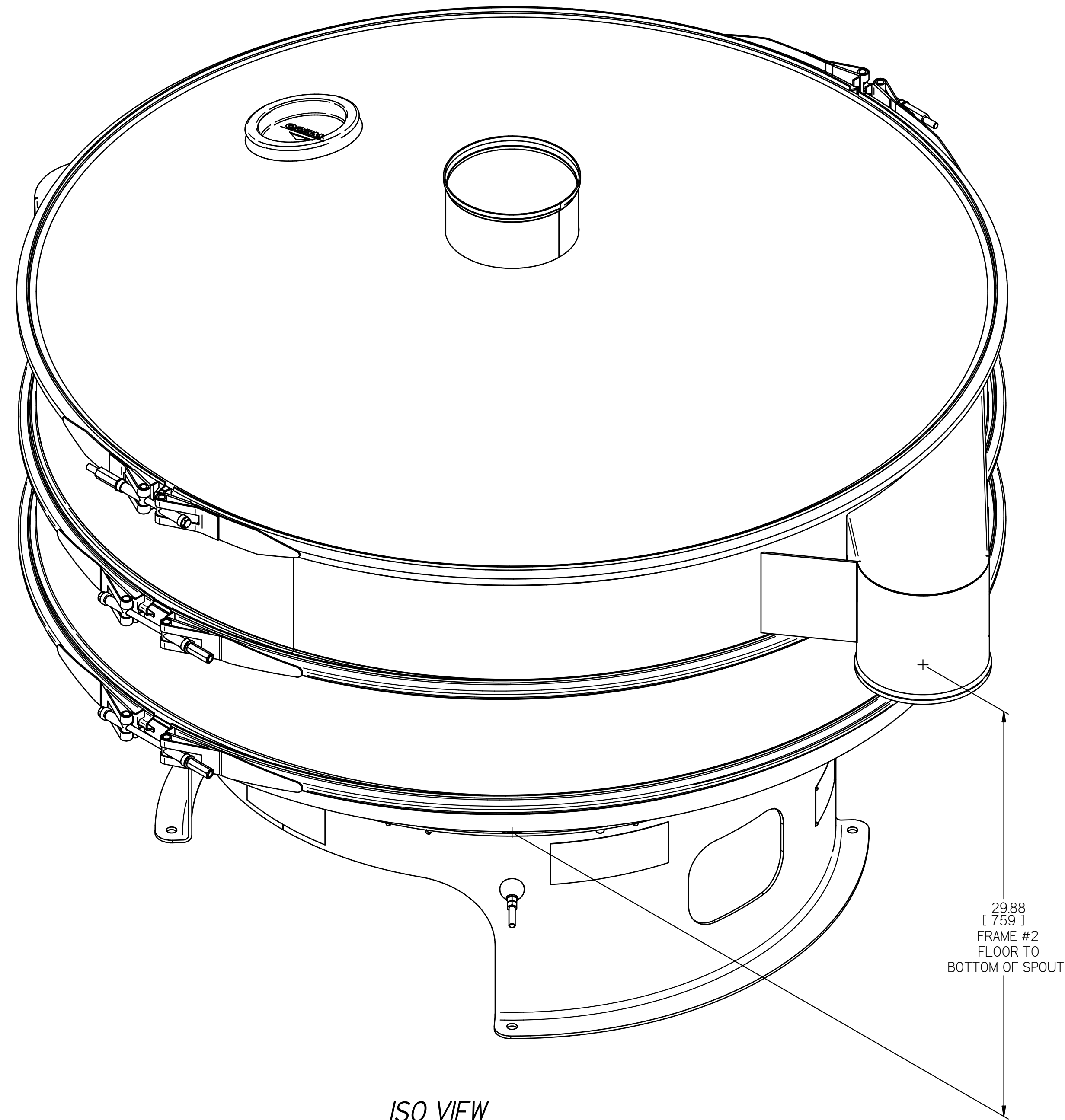

ISO VIEW
1:5

2988
[759]
FRAME #2
FLOOR TO
BOTTOM OF SPOUT

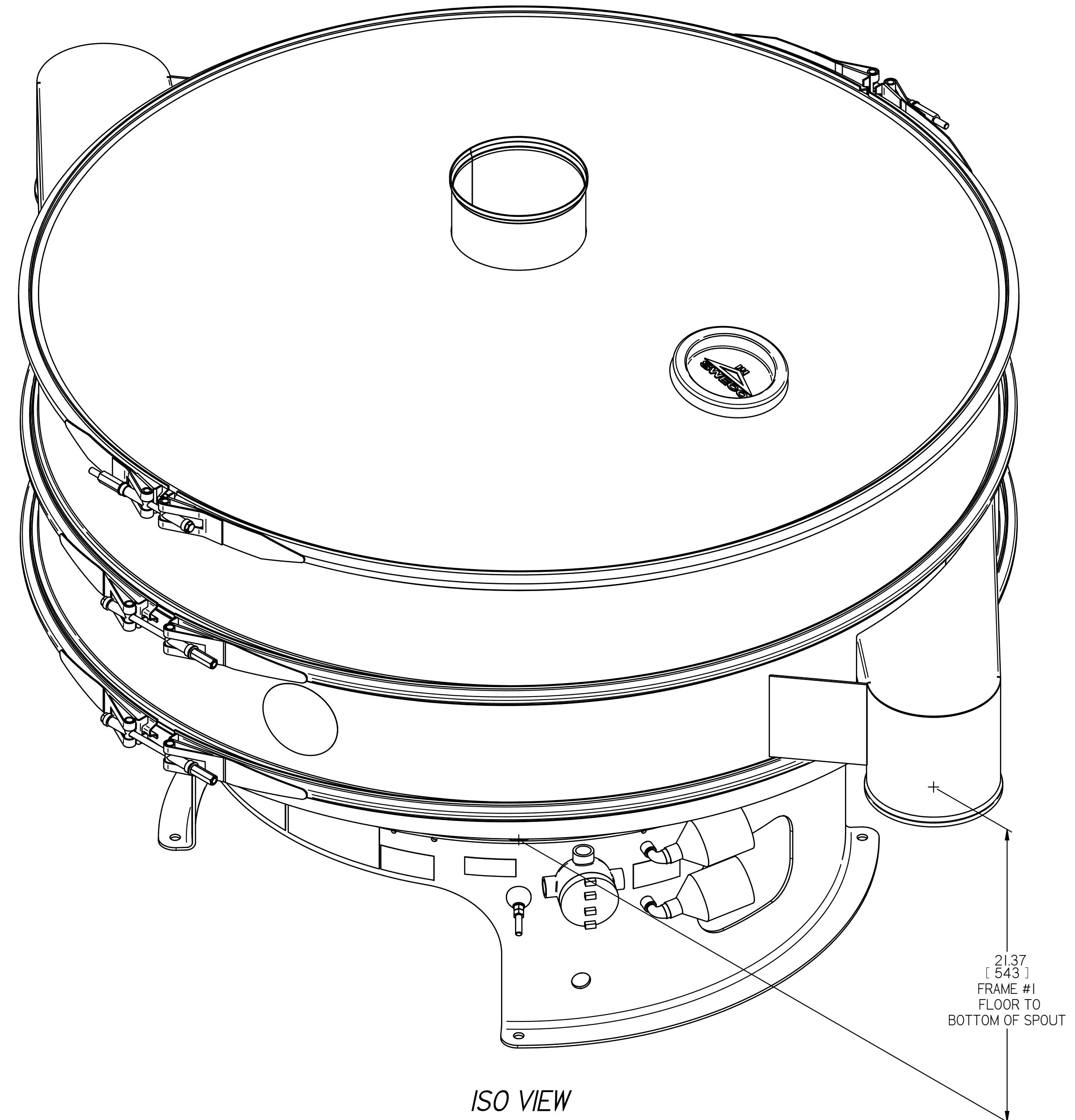

ISO VIEW
1:5

2137
[543]
FRAME #1
FLOOR TO
BOTTOM OF SPOUT

<p>SALES DRAWING ONLY</p> <p>UNLESS OTHERWISE SPECIFIED, ALL DIMENSIONS, SPECIFICATIONS, WEIGHTS, ETC. ARE APPROXIMATE AND SUBJECT TO CHANGE WITHOUT NOTICE PRIOR TO CERTIFICATION.</p>	CUSTOMER	
	XX.	
 <p>THIS PRINT IS THE PROPERTY OF SWECO, BUSINESS UNIT OF M-I, L.L.C. 8029 U.S. HIGHWAY 25 FLORENCE, KY 41022</p> <p>THE INFORMATION DISCLOSED HEREIN INCLUDES PROPRIETARY RIGHTS OF SWECO, DIVISION OF M-I, L.L.C. NEITHER THIS DOCUMENT NOR THE INFORMATION DISCLOSED HEREIN SHALL BE REPRODUCED OR TRANSFERRED TO OTHER DOCUMENTS OR USED OR DISCLOSED TO OTHERS FOR MANUFACTURING PURPOSES, OR FOR ANY OTHER PURPOSES, EXCEPT AS SPECIFICALLY AUTHORIZED IN WRITING BY SWECO, BUSINESS UNIT OF M-I, L.L.C. IF THIS PRINT IS SUPPLIED IN CONNECTION WITH THE SALE OR DELIVERY OF SWECO EQUIPMENT, IT IS TO BE USED SOLELY FOR MAINTENANCE, REPAIR OR INSTALLATION OF SUCH EQUIPMENT.</p>	PROJECT NO.	
	-	
DRAWING NO.		UNIT
HX60_88WC		60" SWECO ROUND SEPARATOR
DRAWN BY		MODEL: HX60_88TLWC
Y.Jain		
DATE		REVISION
I/16/2020		-
UNIT WEIGHT (EMPTY)		
1056 LBS. APPROX.		