

450 Barrel Round Portable Silo



450 Barrel Round Portable Silo

- 10'-8" Diameter x 35'-7" Overall Height
- Positive Feed Drive Auger System
- 9" Diameter Screw x 17'-0"
- 10 HP Motor and Gear Box Drive
- Heavy Duty Dual Axle Trailer and Tires
- Electric Brakes and Lights Package
- 150 Sq. Ft. Bag Area Dust Collector with Air Vibrator
- Pressure Relief Valve
- Two Speed Trailer Jack Set
- 14'-0" Auger Discharge Height
- Outside Ladder with OSHA Compliant Fall Arrest Cable System
- 4" Fill Pipe with Aluminum Adapter
- 20" Non-Pressurized Inspection Manhole
- (8) Externally Mounted Air Pads with Manifold, Regulator, and Check Valve
- Sandblast, Prime, and Paint
- Standard Colors:
RAL 7038 Gray, RAL 9010 White,
RAL 1001 Tan, RAL 1032 Yellow

Options

- 225 Sq. Ft. Dust Collector
- 330 Sq. Ft. Pulse Jet Dust Collector
- Bin Level Indicators
- Single Phase Motor
- Hydraulic Drive Motor
- Motor Starter Controls
- Manual Air Valve Controls
- Upgrade to 12" Screw Conveyor
- 5" Fill Pipe

Specifications

- Empty Weight 12,800#
- Hitch Weight 4,900#
- 1,800 Cu. Ft. Capacity
- 85 Ton Capacity (Cement)
- Output Capacity Approximately 15 Cu. Ft. Per Minute (9" Screw Conveyor)
- Part Number: BST450P-RD-EB

BELGRADE
STEEL TANK



450 Barrel Round Portable Silo

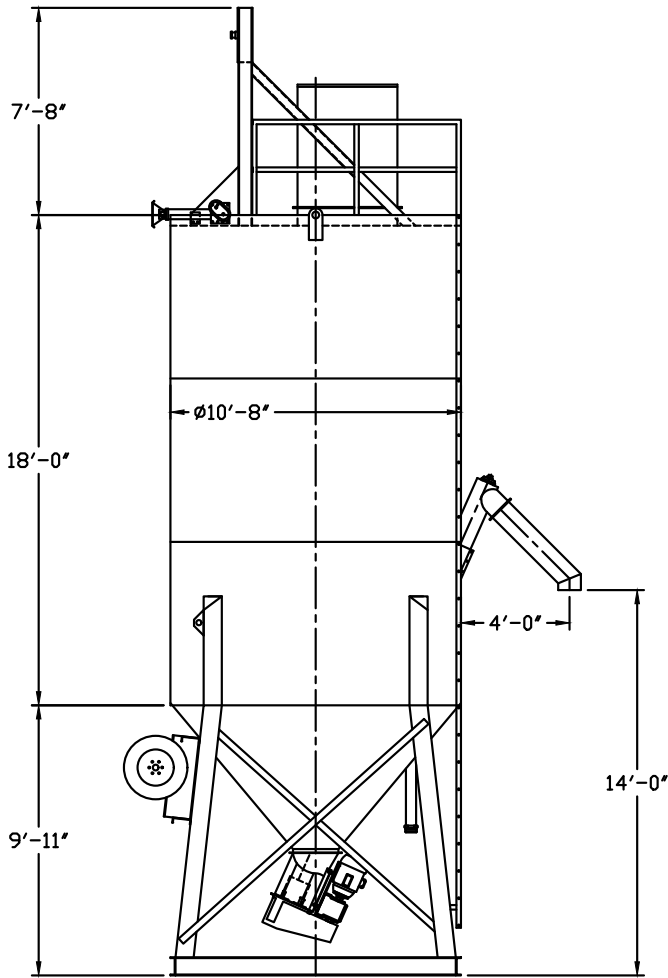

Positive Feed Drive System

