

TABLE OF CONTENT

1	INTRODUCTION	4 -
1.1	GENERAL	4 -
1.2	PURCHASE INFORMATION	4 -
1.2	IF PROBLEMS OCCUR!	5 -
1.3	GENERAL SECURITY CONDITIONS	5 -
1.4	TRAINING	5 -
1.5	RESTRICTIONS IN GUARANTEE	5 -
2	MAIN DATA	6 -
2.1	TECHNICAL DATA	6 -
2.2	WEIGHT & OUTLINE DIMENSIONS	6 -
3	TECHNICAL DESCRIPTION	7 -
3.1	GENERAL TECHNICAL DESCRIPTION	7 -
3.2	CONSTRUCTION, MAIN DESIGN	7 -
3.2.1	<i>Crane pedestal</i>	7 -
3.2.2	<i>Crane king structure</i>	7 -
3.2.3	<i>Hydraulic jib and knuckle jib cylinder</i>	8 -
3.2.4	<i>Slew gear and slew bearing</i>	8 -
3.2.5	<i>Hydraulic system</i>	8 -
3.2.6	<i>Hydraulic winch</i>	9 -
3.2.7	<i>Hydraulic oil tank</i>	9 -
3.2.8	<i>Hoist Up Limits Switch</i>	9 -
3.2.9	<i>Electrical system</i>	10 -
3.2.10	<i>Starter cabinet –ES400</i>	10 -
3.2.11	<i>Remote Start/stop Panel –OP12</i>	11 -
3.2.12	<i>Radio Remote Cabinet –RCC97</i>	12 -
3.2.13	<i>Radio Remote unit –RCC97.1</i>	12 -
4	HANDLING, PRESERVATION & INSTALLATION	13 -
4.1	INTRODUCTION	13 -
4.2	UNLOADING AND HANDLING	13 -
4.3	PRESERVATION	13 -
4.4	INSTALLATION OF UNIT	15 -
4.4.1	<i>Welding to deck structure</i>	15 -
4.4.2	<i>Electrical installation</i>	15 -
4.4.3	<i>Filling the hydraulic system with oil</i>	15 -
4.5	FIRST TIME START UP	16 -
4.6	FUNCTIONAL AND LOAD TEST	16 -
4.7	COMMISSIONING TEST PROCEDURE	17 -
5	OPERATION INSTRUCTIONS	18 -
5.1	START UP OF CRANE	18 -
5.1.1	<i>General check before start</i>	18 -
5.1.2	<i>Check before and during operation</i>	18 -
5.1.3	<i>Start up</i>	19 -
5.2	OPERATING THE CRANE	20 -

5.3	ACTIVATING MAN RIDING MODE FOR PERSONNEL LIFTING	- 20 -
5.4	SAFETY INSTRUCTIONS.....	- 21 -
5.5	SAFETY FUNCTIONS BUILT INTO CRANE SYSTEM	- 21 -
5.6	RADIO REMOTE CONTROL SYSTEM.....	- 22 -
5.6.1	<i>Radio remote cabinet</i>	- 22 -
5.6.2	<i>Radio transmitter unit -A97.1</i>	- 23 -
6	MAINTENANCE	- 28 -
6.1	INTRODUCTION	- 28 -
6.2	ROUTINE MAINTENANCE	- 28 -
6.3	PERIODIC MAINTENANCE PROGRAM	- 30 -
6.4	STANDARD INSPECTION FORM FOR CRANES.....	- 33 -
6.5	INSPECTION LOG.....	- 34 -
6.6	LUBRICATION INSTRUCTIONS.....	- 35 -
6.7	LUBRICATION CHART WITH LUBRICATION POINTS.....	- 51 -
6.8	CHANGE OF OIL FILTER.....	- 53 -
6.9	CHECKING THE HYDRAULIC SYSTEM OIL	- 54 -
7	COMPONENT PARTS LIST	- 55 -
7.1	COMPONENT PARTS LIST	- 56 -
7.1.1	<i>Mechanical part list:</i>	- 56 -
7.1.2	<i>Hydraulic part list:</i>	- 60 -
7.1.3	<i>Electrical part list:</i>	- 61 -
7.2	HYDRAULIC HOSE LIST.....	- 62 -
7.3	ORDERING SPARE PARTS	- 64 -
8	DRAWINGS & DATA SHEETS.....	- 65 -
8.1	PROJECT DRAWINGS	- 66 -
8.2	DATA SHEETS.....	- 67 -
9	STATEMENTS & CERTIFICATES	- 68 -
9.1	CERTIFICATES, LIFTING EQUIPMENT	- 69 -
9.1.1	WIRE CERTIFICATE & SHACKLE CERTIFICATE	- 70 -
9.1.2	<i>Swivel Hook Certificate</i>	- 71 -
9.1.3	<i>Product certificate for crane foundation</i>	- 72 -
9.1.4	<i>Product certificate for hydraulic cylinders</i>	- 73 -
9.1.5	<i>Product certificate for slew bearing</i>	- 74 -
9.1.6	<i>Product certificate for Hoisting Winch & Secondary Gearbox</i>	- 75 -
9.2	FACTORY ACCEPTANCE TEST (FAT).....	- 77 -
10	REMOTE CONTROLLER MANUAL.....	- 78 -
11	HOISTING WINCH MANUAL	- 79 -



This document should be read and fully understood before any service or installation procedure is commenced



1 INTRODUCTION

1.1 General

The User manual is based on the Norwegian Standard 5820. Operators and maintenance personnel must read and understand this user manual before any operations or maintenance of the equipment is commenced. The owner of the equipment is responsible to ensure no unauthorised personnel operate or maintain the equipment.



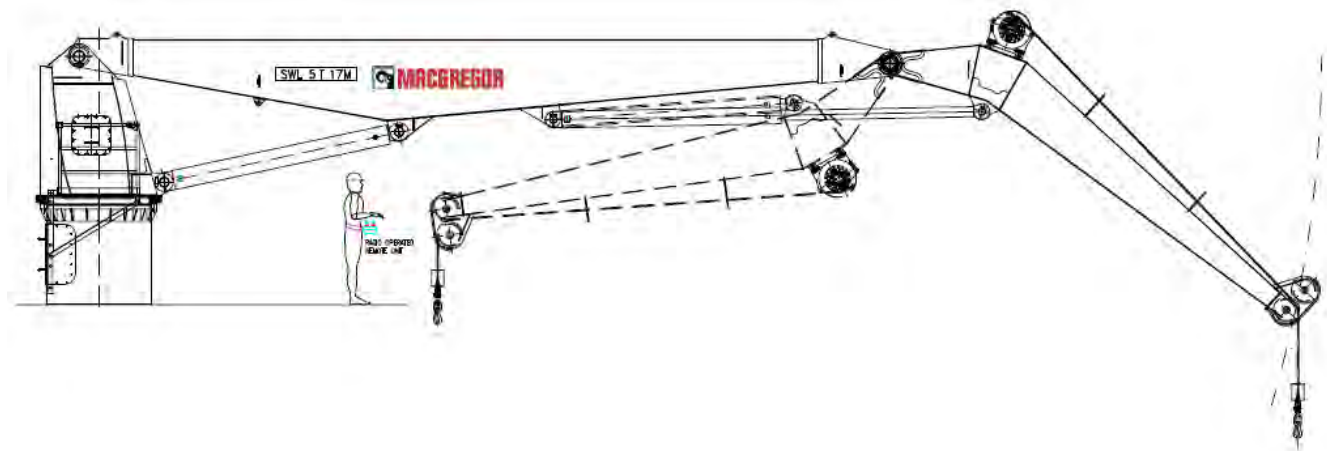

1.2 Purchase information

Equipment:	Knuckle Jib Crane (Shipboard Crane)
Type:	HMC 1610 LK 50-17 (MR9)
Customer:	FURGO GULF, INC.
Project/Vessel:	82.9m VS482 GTRV Multipurpose Offshore Vessel
Project №:	G5005
Machine №:	G5005-1



1.2 If problems occur!

In case of any problems, please contact:

<p>Cargotec CHS Asia Pacific Pte Ltd</p> <p>48 Tuas Road Singapore 638500</p> <p>http://www.macgregor-group.com/service</p>	
 <p>+65 6861 3922</p>	 <p>24 hours service: +47 916 89751</p>
 <p>+65 6862 4334</p>	
 <p><u>service.sin@cargotec.com</u></p>	

Remember to refer to actual equipment machine number for exact definition of components and service advice.

1.3 General security conditions

No personnel are allowed in the equipment working area.

We also want to emphasize that personnel under the influence of drugs, alcohol, strong medication or other preparations which can affect a person's consciousness must not be allowed to operate the equipment. All use of the equipment must comply with the company security regulations.

1.4 Training

Cargotec CHS Asia Pacific Pte Ltd can liaise with **Cargotec Norway AS** to provide tailor-made operation- and maintenance courses to all Cargotec equipment. For more information, contact our Head office in Kristiansand. We recommend all our customers to attend our courses.

1.5 Restrictions in guarantee

During the warranty period, all necessary spare parts must be supplied by **Cargotec Norway AS**. The use of spare parts from other suppliers violates and forfeits the warranty. Unintended use and/or wrong/missing maintenance of the equipment, forfeits the warranty. Removal and/or loss of the equipment identification plates, also forfeits the warranty.

2 MAIN DATA

2.1 Technical data

CRANE DATA	
Crane type	HMC 1610 LK 50-17 (MR9) Classified as shipboard crane under DNV Lifting Appliances 2008. Intended for cargo handling in harbours, sheltered waters, within the deck area or below deck.
Machine №	G5005-1
Safe working load (SWL)	50kN
Working radius max.:	17 m
Working radius min.:	~3.0 m
Hoisting speed	0 - 30m/min
Hoisting height	30 m
Slew sector	360° unlimited
Slew speed	0-1 rpm stepless variable
List/trim, max	5 + 2°
WINCH DATA	
Winch type	BW5200
Wire diameter	Ø 19 mm
HYDRAULIC DATA	
Pump capacity	100 l/min
Max. operating pressure	250 Bar
Hydraulic oil volume	~1300 litres
ELECTRIC DATA	
El. motor type	14BG208-4AA96-Z200L
Power supply	440 VAC, 60 Hz, 3ph
Power, S6-40%	64 kW, 106 A
El. motor heating element	2 x 40 W, 230VAC
Starting method	DOL
Starting current	~490 A

2.2 Weight & outline dimensions

Total weight of crane: ~13000 kg
 Outline dimensions of crane: Reference to drawing № C.1610.188.GA

3 TECHNICAL DESCRIPTION

3.1 General technical description

The HMC 1610 LK 50 – 17 (MR9) knuckle jib type shipboard crane is designed for long time operation in a tough and corrosive environment.

It is classified as a shipboard crane under DNV Lifting Appliances 2008; intended for cargo handling in harbours, sheltered waters, within the deck area or below deck.

The crane is designed for efficient and accurate handling of general cargo of 5 tons at max 17 metres working radius with single fall. The crane is also equipped with man riding mode for personnel handling for a maximum load of 900 Kg.

The crane is equipped with a hydraulic driven winch, jib, knuckle jib and slew system. The hydraulic power unit (HPU) is integrated in the crane, with the electromotor in the foundation. The hydraulic pump is directly connected to the electromotor and sits in the crane king, submerged in hydraulic oil.

For details concerning the valve locations, see enclosed hydraulic flow diagram (chapter 8).

The main control valve is located on platform on the king and directs the hydraulic oil flow from the HPU to the winch, cylinders and slew gear depending on lever position.

3.2 Construction, main design

3.2.1 Crane pedestal

The crane pedestal (also called a foundation) acts as a structural base for the crane system and is designed for welding to a suitable deck structure. The pedestal contains the vertically mounted electrical motor with the hydraulic pump and the oil tank located in above located rotating king. A flexible coupling is installed in between the el. motor output shaft and the pump shaft.

A door or access-hatch for inspection/service is provided in the pedestal structure.

3.2.2 Crane king structure

The rotating crane king is installed on top of the slew bearing above the pedestal. It contains the oil reservoir and acts as the main structural element between the pedestal and the jib system. It is the mounting point for all other parts of the crane.

Plain bushing-style bearings join the jib to the top of the king (as photo at right) and composite spherical bearings connect the jib luffing cylinder to the king. Slewing gear is integrated in the base of the king along with the rotating part of the slew bearing.



3.2.3 Hydraulic jib and knuckle jib cylinder

The jib system is designed to operate the jib to a minimum radius of approximately 3.0m. The jib cylinder is equipped with a pilot operated load holding valve.

The valve has a dual function.

1. Maintaining the speed at a constant value independent of the load.
2. Blocking the cylinder motion in the case of hydraulic pressure loss. This will lock and secure the cylinder position in case of a hose or pipe failure.

3.2.4 Slew gear and slew bearing

The slew bearing is a heavy duty marine slew ring equipped with internal gearing for transfer of the slew torque from the output pinion of the slew gearbox.

The slew gear system consists of one hydraulic driven planetary gear with built in fail-safe dynamic multidisc brake. The brake is dimensioned to take the full load at the maximum list, plus any additional dynamic force acting on the slew gears. In the case of hose or pipe failure, the brake blocks the slewing immediately. A heavy duty hydraulic motor is flanged onto each gearbox. The slew motor, controlled by the main control valve, and the counter balance valve in the loop, give smooth and accurate slewing of the crane.

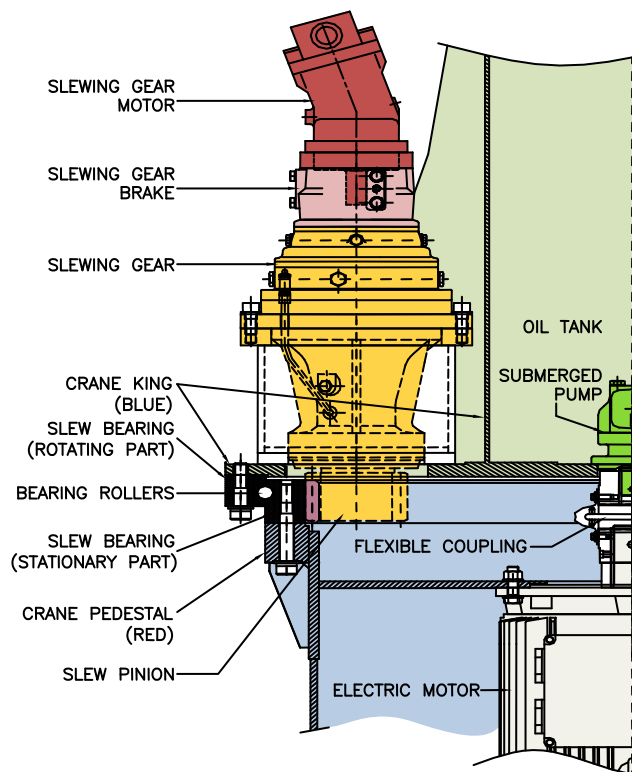

The image above shows a cross-section through parts of the pedestal and king

3.2.5 Hydraulic system

Oil is supplied to the hydraulic gear pump from the oil tank, or reservoir, integrated in the rotating part of king. It's mounted on top of the adapter flange. Between the shafts on the electromotor and the pump, there is a flexible coupling in order to reduce the torsion vibrations.

The flexible coupling also compensates for axial, radial and angular shaft misalignments.

The main hydraulic control valve is installed inside the cabinet placed at crane king rear side.

3.2.6 Hydraulic winch

The winch consists of a steel drum with an axial mounted, flanged on planetary gearbox driven by a fixed displacement hydraulic motor. The gear box is fitted with fail-safe multidisc brakes. The brakes are dimensioned to take the full load plus any additional dynamic force acting on the winch. In case of a hose or pipe failure, the brakes will block the load immediately. A counter balance valve is mounted in the winch loop ensuring smooth and accurate winch operation independent of winch load. The wire rope is galvanised, non-rotating with a counterweight and swivel hook of required capacity.

3.2.7 Hydraulic oil tank

The hydraulic oil tank is integrated as part of the rotating crane king structure (on rotating part of crane). The hydraulic oil pump is of high pressure, low noise gear type and is submerged in the oil tank which reduces the noise level to an absolute minimum. The tank is equipped with visual oil level inspection glass, breather filter, oil filling filter, and a drain valve for use when changing oil and cleaning of the oil tank. Tank is accessed through inspection hatch at the crane king side.

A well dimensioned oil return filter is installed in the system to remove any impurities from the hydraulic oil return flow from system to tank.

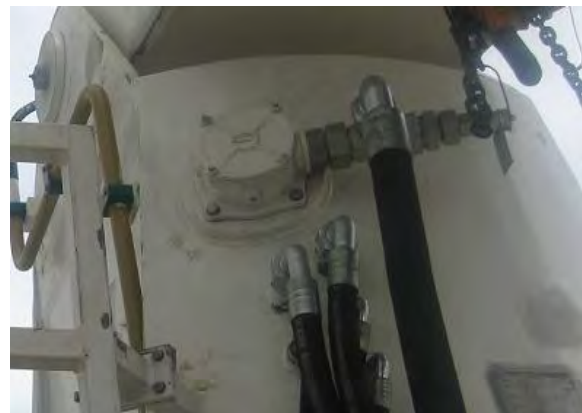

3.2.8 Hoist Up Limits Switch

A hoisting limit switch installed at the boom tip (see figure beside). This limits switch sets the hoist up limit to prevent the hook block from contacting the boom structure. The hydraulic limit switch will cut off the hoist up motion when the hook block contacts with the limit switch.

This hoist up limit switch will take approximately 2 seconds to actuate when the hook speed is at its maximum. The operator should try to avoid hoisting the hook block to the upper limit at maximum speed.



3.2.9 Electrical system

The structure of crane's electrical system is shown below in *Electrical Block Diagram*. It is also enclosed in this manual in chapter 8

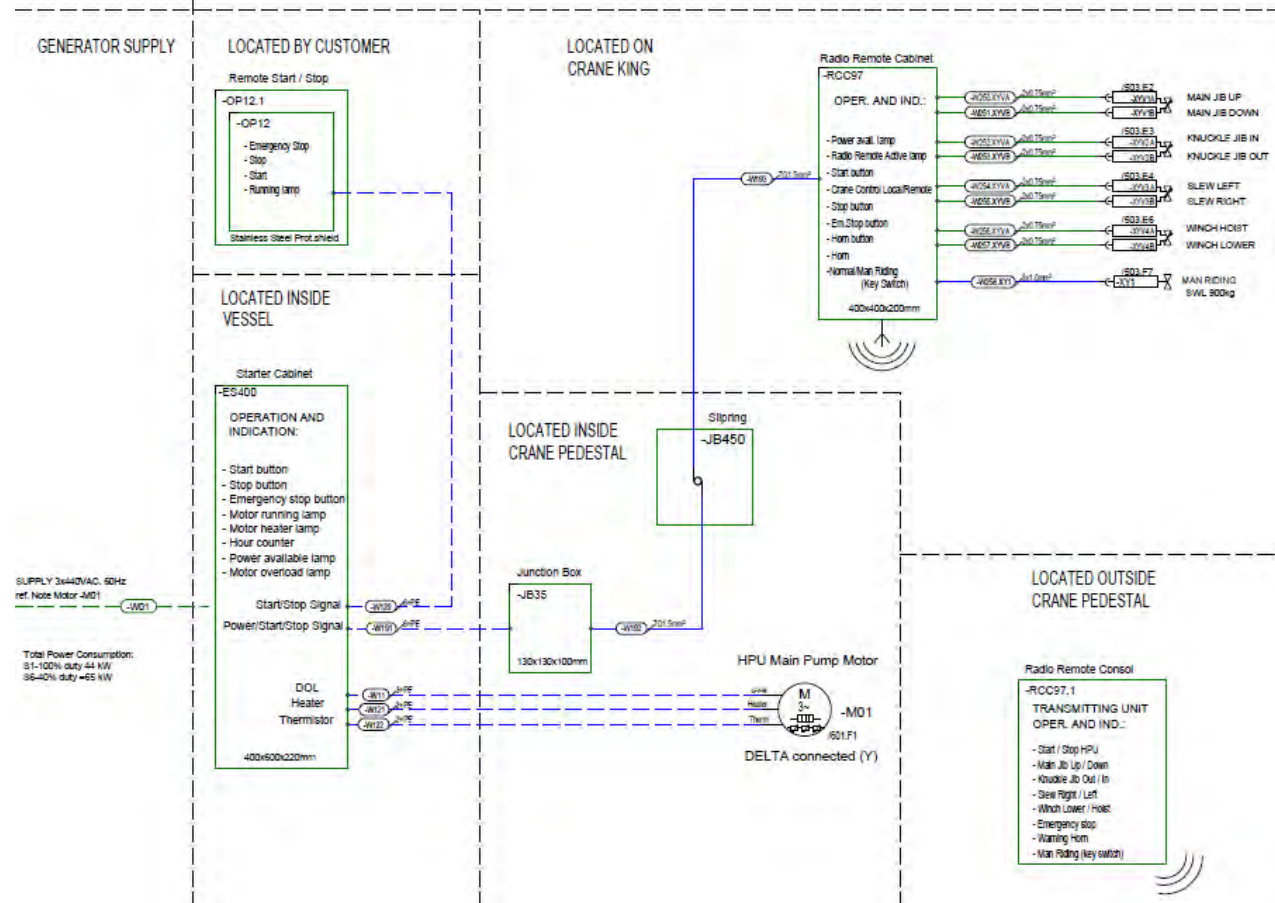

Electrical Block Diagram (typical layout)

Electrical system consists of the following main elements:

- Remote start/stop panel–OP12
- Main Motor –M01
- Starter cabinet –ES400
- Radio Remote Cabinet –RCC97
- Radio Remote Control –RCC97.1

3.2.10 Starter cabinet –ES400

Starter cabinet –ES400 (ref. to Electrical Block Diagram in chapter 8) starts the pump motor. Electric power for the starter cabinet is supplied from the main electric plant on the vessel. Starter cabinet has the following functions:

- Starts of the HPU motor by DOL (Direct On Line) starting method
- Thermistor based motor overload alarm (activated by thermistor relay)
- Motor protection by means of thermistor relay in the starter cabinet
- Power supply for anti-condensation motor space heater
- Power supply for radio remote cabinet –RCC97

- Motor running lamp
- Running hours counter reading
- Normal stop and emergency stop of the HPU motor

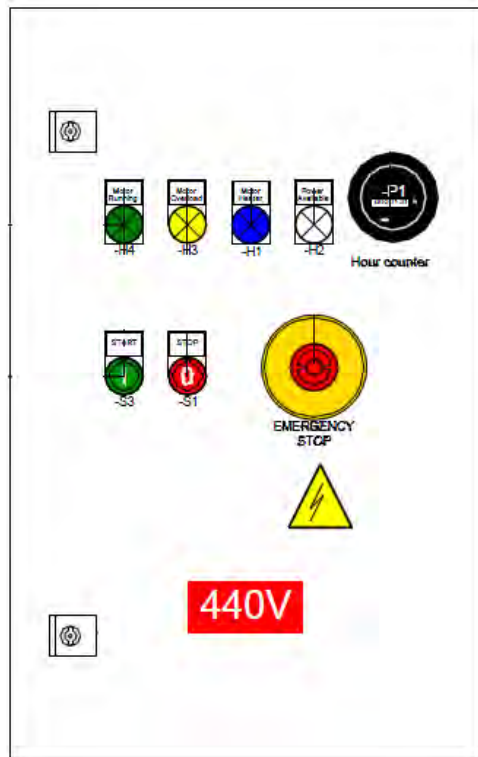

Starter cabinet –ES400

3.2.11 Remote Start/stop Panel –OP12

Remote Panel is supplied with power from the starter cabinet –ES400 (located by customer).

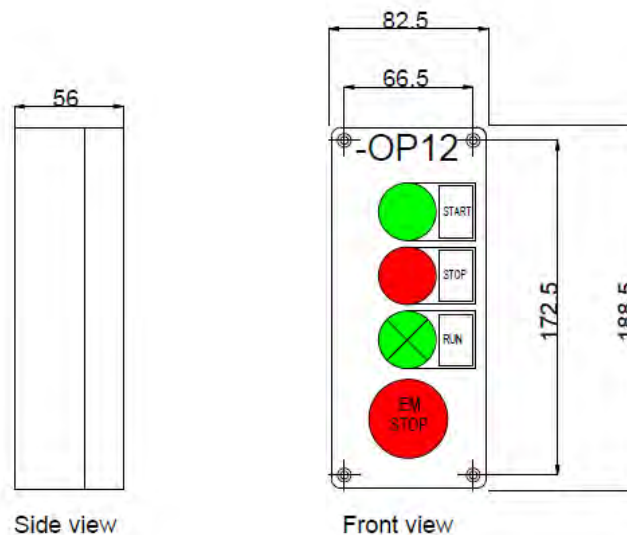

Remote Panel –A12

3.2.12 Radio Remote Cabinet –RCC97

The Radio Remote Cabinet is installed on the crane king. Radio remote cabinet is supplied with power from the starter cabinet –ES400 (located by customer).

The radio receiver module sits inside, connected to an outside mounted antenna.

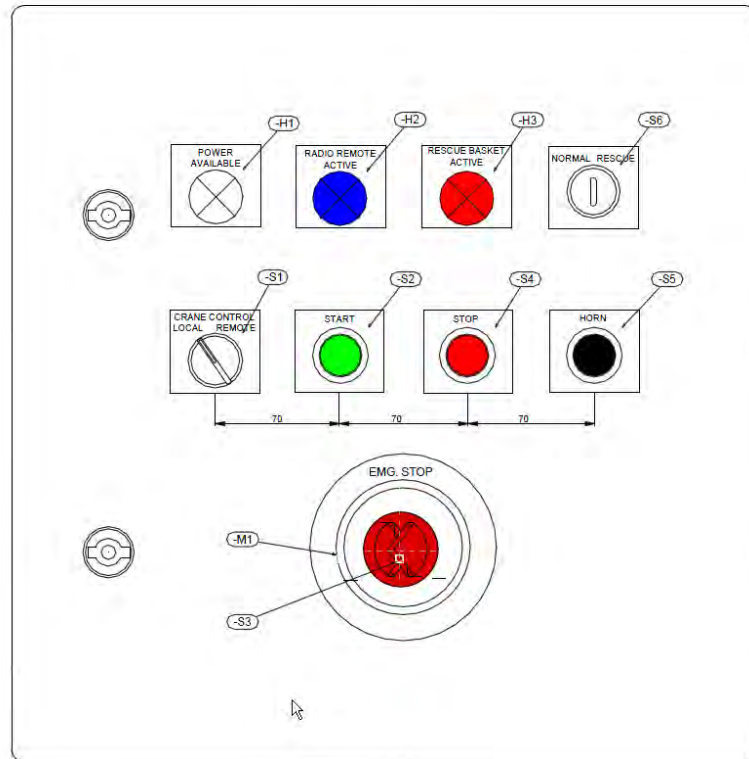

Radio Remote Cabinet –RCC97

3.2.13 Radio Remote unit –RCC97.1

Radio remote control enables the crane operator to control the crane from a distance. It comprises a portable RF transmitter unit which communicates with a receiver unit sitting inside the remote control cabinet –RCC97.

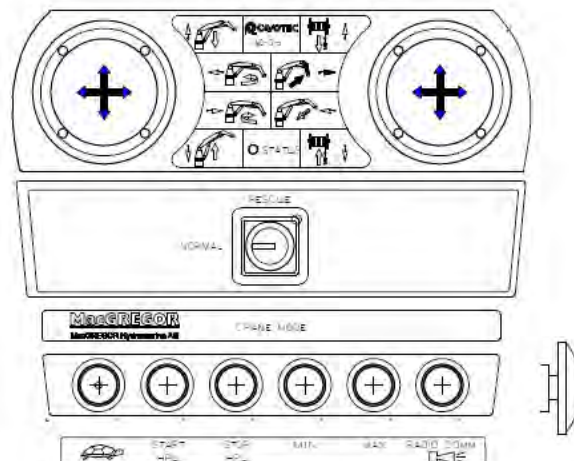

Radio Remote Unit –RCC97.1

4 HANDLING, PRESERVATION & INSTALLATION

4.1 Introduction

The purpose with these procedures is to:

- 1) Ensure that the units are handled / lifted in a safe and correct way in order to avoid damages on personnel or equipment.
- 2) Ensure up to 2 years storage with quality, performance and total lifetime unaffected.
- 3) Ensure that the installation/first time start up, is performed in a safe and correct way.

4.2 Unloading and Handling

The crane is equipped with 2 pairs of lifting lugs, placed on the main jib for safe lifting. See enclosed General Arrangement for placement (chapter 8).

4.3 Preservation

Storage prior to installation (0-6 months):

The crane is delivered as shown in transport drawing below.

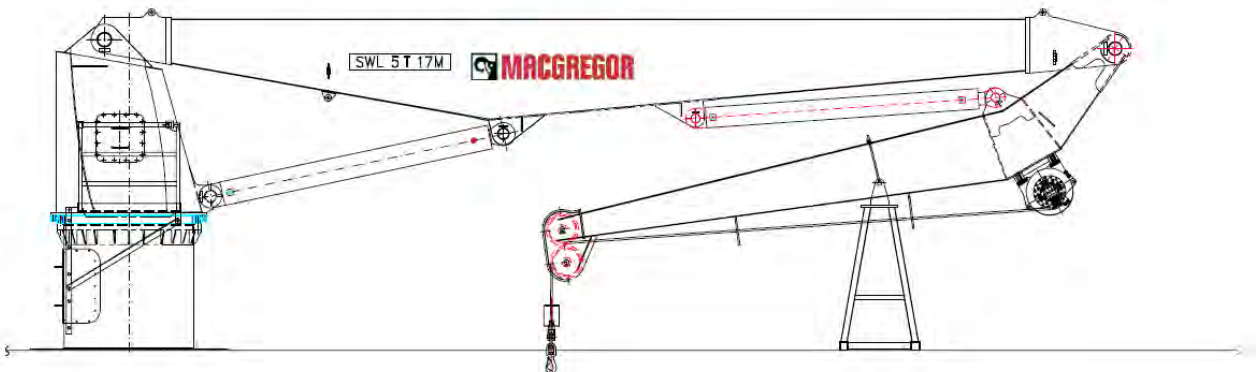

When the crane is temporarily stored (until 6 month) before installation at site, following requirements for preservation should be performed:

Table 4.3.1

Item to be checked	Preservation	Performed	Sign.
In general for all items on the crane	To be washed free from saltwater and dried before being stored indoor or in plastic wrapping. Placed on wooden pallets		
All loose hydraulic hoses and all hydraulic component ports	Plugged and blinded with solid metal plug		
Hydraulic cylinder rods, extended rods	Apply a thin grease layer		
All lubrication nipples	All nipples to be filled with standard grease		
All machined surfaces without surface protection	To be temporarily protected by applying a thin tectyle or grease layer. To be washed off before installation		
Gear box	Filled to normal oil level		
All outside machined surfaces for interconnection to substructure	Waxed or treated with a tectyle product		
Paint, in general	Check that all parts of crane is fully painted, according to procedure		

Storage beyond 6 months

Same procedure as for 0-6 months, including following additional points:

1. All checkpoints according to table 4.3.1 to be performed every 6th month.
2. Lubrication applied at every lubrication point on the crane each 6th month according to chapter 6 in this manual.
3. Power supplied to the electric motor's two internal space heater elements. This is to prevent condensation in the electric motor.
4. All packages with electrical components to remain unpacked and stored indoor to maintain dry conditions.

4.4 Installation of unit

4.4.1 Welding to deck structure

Cargotec cranes are normally delivered for welding directly to deck or some other type of substructure.

As a minimum requirement the deck structure must be designed to withstand the cranes maximum bending moment with necessary safety factor.

(See general arrangement for forces to substructure)

CHECK THE FOLLOWING:

- Deck structure must be free from cracks, rust, oil and other elements that will inhibit welding of foundation to surface.
- The foundation is equipped with a groove at deck, as a minimum this groove must be filled. Welding must be done only by certified

4.4.2 Electrical installation

The crane is delivered as a complete unit with the electromotor built into the crane base. The motor is equipped with heating element(s), which must be "on" when the crane is not in use.

CHECK THE FOLLOWING *before start up of system:*

- Connect the electromotor in accordance with the electric starter diagram. The crane is running in S6-40% mode according to NVE-1990-FEA-M.
- Always check electrical connection with the motor sign
- Connect electric starter and remote start/stop in accordance to the electric starter diagram
- Provide a drain in the foundation in order to avoid damaging the electric motor, due to condensation etc.
- Certified electrician to be used

4.4.3 Filling the hydraulic system with oil

After installing the crane onboard, fill hydraulic system oil on tank located in crane king. The hydraulic oil shall be filled through a quick release coupling placed at the systems oil filter. Oil filter is placed in crane king.

Fill the approved hydraulic system oil into tank. The oil level should be visible at all times. (To be filled to top of level glass).

Always use new, clean oil. Under no circumstance water, dirt or other impurities must be allowed to enter the tank. Impurities and moisture will reduce the efficiency and shorten the lifetime of the hydraulic system.

4.5 First time start up

As a final check before first time start up, check the rotation of the electric motor. This is done by a SHORT start of the motor while observing the rotation. If the rotation is wrong, interchange 2 phases and check again.



**It's very important to ensure correct rotation direction for the hydraulic pump before taken into service.
Any discrepancy between indicated rotation on electromotor and pump must be clarified with Cargotec prior to start up of a new or changed equipment.**

The hydraulic pump must not be allowed to run in the wrong direction, as this will seriously affect its life span.

Some air will be present in the system when it's started for the first time. Let the power pack run for a couple of minutes without pressure, shut down for 10 minutes and restart. The winch and the slew will automatically release air from its system when operated. Be sure that all air in system is ventilated before any load is applied.

Upon completion of initial test run, check the oil level in the system oil tank and top up if necessary.

4.6 Functional and load test

Execute all functions mentioned in the commissioning test procedure (enclosed), before the crane is taken into normal operation.

The committed tests are usually a normal function test and a load test for 1.25 x SWL.

4.7 Commissioning test procedure



**CTP
COMMISSIONING TEST REPORT
for
HMC 1610 LK 50-17 (MR9)**

Equipment:	Knuckle Jib Slewing Crane
Type:	HMC 1610 LK 50-17 (MR9)
Test Date:	
HM mach. no.	G5005
Production year	2011
Test manager	
Project Engineer	
Third Party witness	-
Client representative	
Design Standard:	<i>DNV</i>

Item	Description	page
1	INITIAL CHECK (PREPARING FOR TEST):	3
2	TEST OF REMOTE CONTROL	4
3	LOAD TEST, 1.25 x SWL:	4
4	AFTER TEST.	5
5	PUNCH LIST	5
6	SIGNATURES.	5

MacGREGOR Hydramarine Crane - FAT Procedure

1 INITIAL CHECK (PREPARING FOR TEST):				
Ref:	Description of activity:	Specified data:	Verification:	Comments:
1.1	Welding to test foundation.	To be welded as specified in dwg. C.1610.188.GA		
1.2	<u>Check of bolt connections:</u> - Slew bearing. (Upper/lower) - Jib bolts. - Cylinder bolts - Slew gear	<u>Bolt / Torque:</u> M24-10.9 760 Nm M14-8.8 100 Nm		Ref. HM doc. no.: T0001, Tightening torques / Bolt tensioning forces.
1.3	<u>Check of grease nipples:</u> - To be free of paint. - Filled up with grease. - To be protected with red caps	- Slew Bearing - Cylinder Bolts - Sheave Bolts - Jib Bolts		
1.4	<u>Check of Oil Levels:</u> Levels to be checked and top up if required after first start up.	- Winch Gear. - Winch Brake Oil - Slew Gear - Slew Brake Oil - System oil.		
1.5	Visual check of hoses / couplings	- Routing for hoses is acceptable. - All couplings are tight.		
1.6	Check of crane control system	- Operator panel - Communication OK between PLC and operator panel		
1.7	Verify supply voltage.	- 3x440VAC, 60Hz		
1.8	<u>Electrical motor :</u> - Rotation of pump, seen from fan end of el. motor. - Verify thermistor of el. motor - Motor Power supply	- Clockwise rotation - 3x440VAC, 60Hz		
1.9	Start system non-pressurised. Check for leaks.			
1.10	<u>Movements of crane</u> - All motions to be activated to extreme positions. - One person to observe motions and rotating parts	- Winch Up/Down - Slew Right/Left - Main Jib Up/Down - Knuckle jib in/out		
1.11	Check that wire runs free in all crane positions.			
1.12	Normal/ manriding mode: Manual select	- Hoisting pressure: ~75BAR (set to lift max. 0.9T)		
1.13	Check painting of the crane in general.	- All components painted		

MacGREGOR Hydramarine Crane - FAT Procedure

2 TEST OF REMOTE CONTROL

Description of activity:	Specified data:	Verification:	Comments:
Verify correct operation of following functions by using portable panel:			
Winch up / down			
Slew left / right			
Main jib up / down			
Knuckle jib out / in			
Emergency stop			
Start/stop of HPU			
Normal/ Manriding mode	Hoisting pressure: ~75BAR (set to lift max. 0.9T)		

3 LOAD TEST, 1.25 x SWL:

Ref:	Description of activity:	Contract requirements:	Hydramarine calculated value:	Verification:	Comments:
3.0	Load test to be performed with test - load 1,25 x SWL in hook.		Test-load: 6.25T		
3.1	<u>Winch lifting performance.</u> <ul style="list-style-type: none"> - Operate winch down, and verify control performance - Verify brake holding function - Read operation pressure winch hoist. 		P _{is} : 250 bar	Up= bar Down= bar	
3.2	<u>Crane slew performance.</u> <ul style="list-style-type: none"> - Verify slew performance in all positions. - Read operation pressure. 			Right= bar Left= bar	
3.3	<u>Crane jib performance.</u> <ul style="list-style-type: none"> - Verify crane jib performance in all positions. - Read operation pressure. 			Up= bar Down= bar	
3.4	<u>Crane knuckle jib performance.</u> <ul style="list-style-type: none"> - Verify crane knuckle jib performance in all positions. - Read operation pressure. 			In= bar Out= bar	

MacGREGOR Hydramarine Crane - FAT Procedure

4 AFTER TEST.				
Item.	Description of activity	Specified Data	Verification:	Comments:
4.0	All ball valve back to normal operation position.	Ref. Hyd. Flow Diagram Dwg. C.1610.188.HF01		
4.1	Main relief valve setting to SWL.	Ref. Hyd. Flow Diagram Dwg. C.1610.188.HF01		

5 PUNCH LIST		
Item.	Description	Comments:
5.0		
5.1		
5.2		
5.3		
5.4		
5.5		
5.6		
5.7		

6 SIGNATURES.					
Cargotec representative:		Client representative :		Third Party witness:	
_____	_____	_____	_____	_____	_____
date	name	date	name	date	name

5 OPERATION INSTRUCTIONS

5.1 Start up of crane

5.1.1 General check before start

Before the crane is started and a new lifting operation is performed the operator must check the crane to make sure it is fit and ready for the job.

The following conditions are to be checked by the operator but are not limited to:

1. Weight, COG and shape / added mass of the load(s) to be lifted.
2. Weather / environmental conditions.
3. Evaluate if the actual lift job is secure with respect to pts. 1 and 2.
4. Check that lifting- / loose gear is fit for purpose by a visual inspection of equipment and certificates.
5. A visual check of crane, wires, wire sheaves, engine room with pumps, hoses, oil tank level and valves. Check for leakages, visual defects etc. before start up.

5.1.2 Check before and during operation

Make sure that starter cabinet –ES400 is supplied with power from the vessel. No crane operation is possible until the electric motor is running.

The following conditions are to be checked by the operator but are not limited to:

1. Communication between crane operator and slinger is satisfactory.
2. Correct function of crane control system, limiting devices, indicators and protection systems (when applicable).
3. A plan is made for safe lifting operation. Correct crane lifting mode to be selected considering the environmental conditions within the given limits, correct use of slings, shackles, chains etc.
4. Pay attention to the crane control system and respect the warnings and alarms given by the system (when applicable).
5. Check that the crane is fit and rigged for the actual job. Winch, single part, double part, hook height above deck, actual radius etc.
6. Deck area for pick up and landing of loads and the routing between must be checked for obstructions, clear view and maximum load impact limitations to deck.

5.1.3 Start up

Make sure that starter cabinet is supplied with power from the vessel. If not, provide starter cabinet with power. No crane operation is possible until the electric motor is running.

The HPU can be operated from starter cabinet (-ES400), from remote panel (-OP12) or from the portable radio transmitter unit (-A97.1).

1. Starter Cabinet –ES400

First:

- Check for lit white indicator lamp “POWER AVAILABLE”

And:

Radio Remote Cabinet –A97:

- Check for lit white indicator lamp “POWER AVAILABLE”
- Turn switch “CRANE CONTROL LOCAL/REMOTE” to “LOCAL” position

Then:

Starter Cabinet:

- push button “START ” to start motor

2. Remote Start/Stop Panel –OP12

First:

- Check for lit white indicator lamp “POWER AVAILABLE” on starter cabinet
- Push button “HPU MOTOR START” to start motor

3. Radio Remote Cabinet –A97

First:

- Check for lit white indicator lamp “POWER AVAILABLE”
- Turn switch “CRANE CONTROL LOCAL/REMOTE” to “LOCAL” position
- push button “HPU MOTOR START” to start motor

4. Radio transmitter unit –A97.1

First:

Radio Remote Cabinet –A97:

- Check for lit white indicator lamp “POWER AVAILABLE”
- Turn switch “CRANE CONTROL LOCAL/REMOTE” to “REMOTE” position

Then:

Portable radio transmitter –A97.1:

- activate the unit by turning start key on left hand side to “I” position
- Check for lit blue lamp “RADIO REMOTE ACTIVE” on –A97, indicating established contact with receiver inside
- push forward switch “HYDRAULIC POWER UNIT” to start motor

Once the pump is running, make sure that the Man Riding Switch is turn to the “Normal” setting for normal cargo handling. The crane is then ready for operation.

5.2 Operating the crane

The proportional control valve is located on the platform banister. The valve consists of the following sections:

- № 1 from left: Slew left/right
- № 2 from left: Main jib up/down
- № 3 from left: Knuckle jib in/out
- № 4 from left: Winch up/down

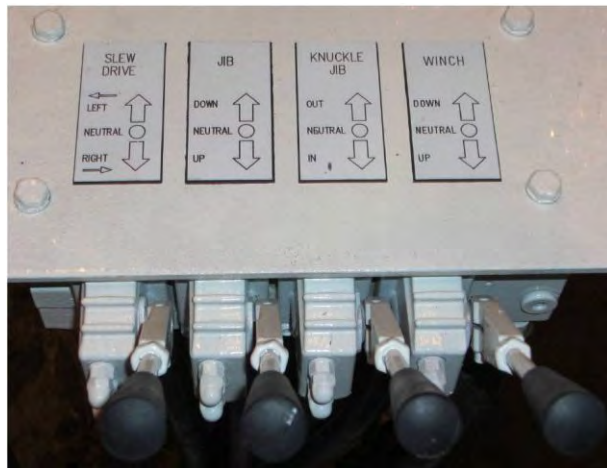

5.3 Activating Man Riding Mode for Personnel Lifting

When the crane is used for any personnel lift, the man riding mode must be selected. Once the man riding mode is activated, the safety system in the crane will limit the Safe Working Load to 900 Kg.

The man riding mode can be selected at the switches located at the:

1. **Radio Remote Cabinet –A97 .**
Switch the “Man Riding” switch from “Normal” to “Rescue”
2. **Radio transmitter unit –A97.1**
Switch the “Man Riding” switch from “Normal” to “Rescue”

In case of emergency when both of the switches are not functioning, an emergency hand operated valve can be used to activate the man riding mode.

Pull the level on the valve and keep the pressure on, and move the control levels to control the crane movement.



Manual override lever for ManRiding mode

5.4 Safety instructions

Never handle loads exceeding the winch lifting capacity. The jib system is able to lift heavier loads at reduced radius. When lifting heavy loads, always make sure that the winch is able to lift load before any further jib operation.

Always observe the risk of collision with superstructures when slewing.

5.5 Safety functions built into crane system

Safety systems

The crane is fitted with the following safety systems:

Emergency stop 1 is fitted on the Radio Remote Cabinet –A97

Emergency stop 2 is fitted on the radio transmitter unit -A97.1



Emergency stop 2 is functional only when radio remote control is activated (radio remote cabinet and transmitter unit is activated).

Emergency stop 3 is fitted on the starter cabinet –ES400

Emergency stop 4 is fitted on the remote start/stop panel –OP12

If any of these buttons are activated, the main pump will stop and the pressure will drop (see exception for Emergency Stop 2).

Spring centred control valves

All control levers, separate and joy stick type, are spring centred. In order to operate the crane the relevant control lever has to be pushed in the required direction to cause the desired motion. Once the lever is released it will return to its centre position, and the motion will stop instantly.

Overload protection

Each crane motion is protected from overload by a hydraulic relief valve. If a particular motion that exceeds the designed crane load is tried, the relief valve relevant for the particular motion will feed a return flow of the hydraulic oil into the oil tank. Hence, the crane motion is disabled and cannot be executed.

Luffing cylinder limitation

The hydraulic cylinder for luffing of the crane jib is fitted with a mechanical stroke limitation. The limitation allows the luffing to be executed at full speed.

Load holding brakes

The hydraulic cylinder for luffing of the crane jib section is fitted with pilot operated load holding valve. The valve is mounted directly to the cylinder port and has a dual function:

- 1 Maintaining the luffing speed at a constant value independent of the load
- 2 Blocking the cylinder motion in the case of hydraulic pressure loss. This will lock and secure the cylinder position in case of a hose or pipe failure.

Fail safe brakes

Both the winch and the slew gearbox are fitted with hydraulic operated, oil submerged, failsafe, multidisc brakes. In case of a hydraulic pressure loss due to hose/pipe failure, the brake will engage automatically and stop the relevant motion.

5.6 Radio remote control system

The radio remote control system comprises a radio remote cabinet –A97 and RF transmitter unit –A97.1.

5.6.1 Radio remote cabinet

Radio remote cabinet –A97 layout is previously shown in chapter 3.

It has the following switch button and indicator lamps:

- “POWER AVAILABLE” white lamp
- “CRANE CONTROL LOCAL/ REMOTE” switch
- “RADIO REMOTE ACTIVE” blue lamp

Before any radio remote operation is carried out, be sure the listed conditions are met:

- Supply starter cabinet –A01 with power, indicated by lit white lamp “POWER AVAILABLE”. Power to crane and control system is distributed via –A01.
- Turn switch “CRANE CONTROL LOCAL/REMOTE” to “REMOTE” position
- Switch on radio transmitter unit. Check for lit blue lamp “RADIO REMOTE ACTIVE”, indicating established connection.

5.6.2 Radio transmitter unit -A97.1

Transmitter unit is shown below

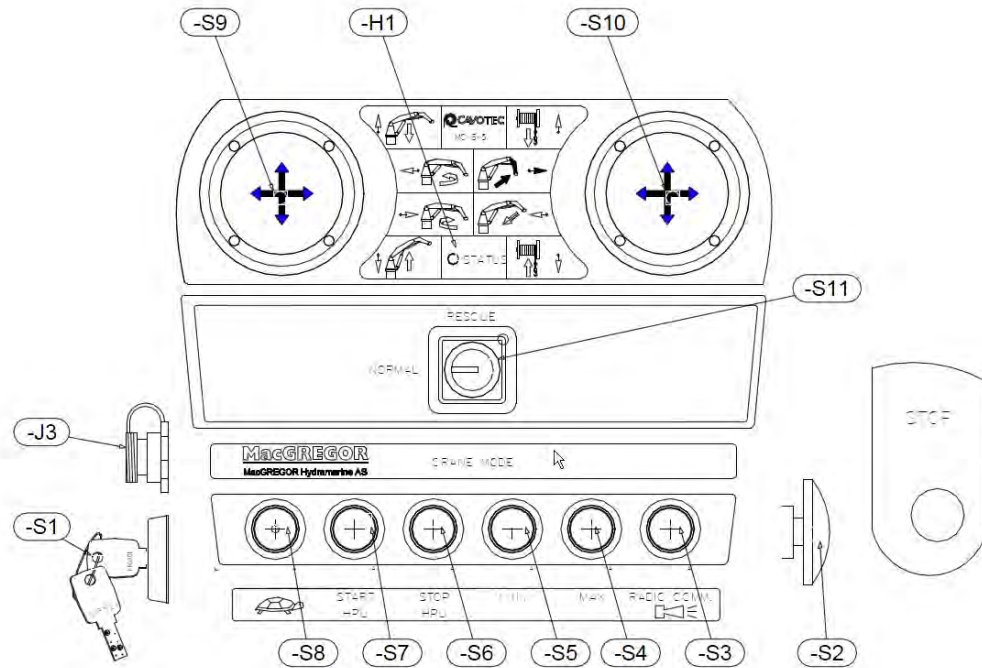

RF Transmitter unit (typical)

S1	Activation Key
S2	EMERGENCY STOP push button
S3	Warning Horn/ Radio Communication Button
S6	HPU Stop Button
S7	HPU Start Button
S8	Speed Selector
S11	Man Riding Mode Selector
H1	System Status LED

The transmitting unit is equipped with two joysticks:

Left joystick (S9):

Slew left/right

Main jib up/down

Right joystick (S10):

Knuckle Jib out/in

Winch up/down

Power on and starting

Check that unit has a fully charged battery and that EMERGENCY STOP button on the right hand side is not engaged (pushed). Turn the "TERMINAL" key to ON position. Push the "Radio Comm" button to establish communication with the receiver unit at the Radio Control Cabinet. After a short self test the terminal will establish contact with the base unit.

The transmitter unit switches on only if the battery is sufficiently charged and all the actuators are inactive.

Commands

It is possible to control the crane only when the transmitting unit is radio linked to the receiving unit, signaled by lightning up of the ENABLE pilot light on the receiving unit. (see chapter 10 Radio Remote Control User Manual)

"Radio Comm" button also activates warning. This horn can be used to alert people in vicinity of the crane. Do not hesitate to alert possible dangerous situations with the horn.

Start/Stop Hydraulic Power Unit

Switch the "Terminal On/Off" switch to on position.

Push the "Radio Comm" button to establish communication with the receiver unit at the Radio Control Cabinet

Push the "Start HPU" button to start hydraulic power unit.

Push the "Stop HPU" button to stop hydraulic power unit.

Activating Man Riding Mode

Switch the "Man Riding Mode Selector" to "Rescue" position. Operate the crane using the joysticks.

By switching to the Man Riding Mode, the system will limit the Safe Working Load of the crane to 900 Kg.

Emergency STOP

To immediately stop the crane, press the EMERGENCY STOP button; the transmitter unit switches off and an emergency security circuit stops hydraulic power unit.

To resume operation, disengage the EMERGENCY STOP button and repeat the power on and starting procedure.



Using EMERGENCY STOP button is mandatory when the crane has to be stopped immediately to avoid a dangerous situation

LED signals

Some transmitting unit operating conditions are indicated by a yellow signaling LED:

TYPE of SIGNAL	LED	Action
Steady light	Normal operation	None
Slow flashing	Low battery voltage	Replace battery
3 flashes with a stop	Radio fault	Replace radio module
6 flashes with a stop	Inactivity shutdown	Turn terminal OFF and ON to resume
For complete legend, see chapter 10		

When the battery is nearly discharged, the LED will start flashing. In this situation, the operator must return the machine to a safe condition by switching off the transmitting unit or pressing the Emergency Stop button. Recharge the battery and/or refit a fully charged battery.

Power off

Switch the “Terminal On/Off” switch to OFF.

Automatic power off

The transmitting unit will switch off automatically when:

- the battery is not sufficiently charged and/or
- the radio remote control is remained unused for 3½ minutes

Recharging the battery

Remove the battery from the transmitting unit and insert it to the battery charger. The “ON CHARGING” tricolor LED will illuminate red to indicate charging of the battery. Once the battery is fully charged, the LED will illuminate green. Leave the battery in the charger until needed. If battery or charger is outside the temperature range +10°C to +40°C, the LED will illuminate yellow and charging will fail.



See *chapter 10* for further instructions, warnings and technical data regarding batteries and battery charger.

Wire control

It is possible to operate the crane from the Radio remote unit in non-radio mode. It is called “Wire control”. In this mode, the battery may be removed from the transmitting unit. Supplied cable is intended for wire control.

Operator should connect operator panel and transmitting unit by means of wire control cable.

Radio remote cabinet –A97 is equipped with a cable connector (see *picture below*). It is typically mounted in the enclosure bottom, next to the antenna.



Underside radio remote cabinet –A97 (typical)

Wire control is obtained by following the instructions:

- 1) Remove connector plug cover from the cable connector on the bottom of RC cabinet –A97 (see *picture above*). The cover is removed by turning it CCW
- 2) plug cable into cable connector on RC cabinet –A97
- 3) remove connector plug cover from transmitting unit –A97.1 cable connector
- 4) plug cable's loose end into connector on –A97.1 transmitting unit, left side
- 5) proceed with power on and starting procedures: turn the key to ON
- 6) push "START HPU" to start HPU motor
- 7) perform crane operations by using joysticks
- 8) when crane operations are finished push "STOP HPU" to stop HPU motor
- 9) turn the starting key to OFF. Always remember to remove the starting key and put it in a safe place
- 10) unplug cable both from transmitting unit and operator panel
- 11) replace connector plug covers
- 12) keep the cable in a safe place

General warnings regarding use of radio remote control



An operator must only utilize the radio remote control when *this manual is read and fully understood and necessary skill is obtained through adequate training*



Every time the transmitting unit is powered, ensure that Emergency Stop button operates correctly. When pressed, crane movements should instantly be interrupted. If this doesn't happen, do not use the radio remote control



The operator should always check for damages on units, including gaskets, bellows and hoods of actuators (joysticks, selectors, pushbuttons). If any, the radio remote control must not be used until required repair is done



To work efficiently and to prevent possible emergency situations, it is necessary to select a position from where it is possible to:
-remain within the typical working range of the radio remote control
-visually follow the crane, its movements and a possible load at all times

During operation



The operator must:
-switch off the transmitting unit each time work is stopped
-NEVER leave the transmitting unit unattended in On position.
-avoid working if the battery is almost flat



The operator should never switch on and activate the transmitting unit unless ready to start working. A radio link may establish even outside the active range and from enclosed places, making the radio remote controlled crane carry out undesired commands

In case of danger



If a dangerous situation arises, the operator must intervene immediately by pressing the EMERGENCY STOP button, which instantly interrupts crane movements.



As not all damages are caused by the "radio remote control + crane" system, the operator should always be careful and alerted towards potential emergency situations within the working area. The operator should, also in such cases, intervene manually by activating the EMERGENCY STOP button.

In case of fault



In case of faults or damaged parts, ALWAYS STOP the "radio remote control + crane" system until the problem has been solved.
Damaged parts can be replaced ONLY by personnel authorized by manufacturer, utilizing original spare parts.

6 MAINTENANCE



Maintenance!

During the warranty period, all maintenance described in this user manual must be carried out and documented. Either in the enclosed maintenance log or in the vessel's maintenance log. Lack of documented maintenance violates and forfeits the warranty.

6.1 Introduction

Cargotec has developed a periodic maintenance program in accordance with the supplier's maintenance program for each of the crane components. Adhering to this program will ensure long-time, trouble-free operation and significantly reduce unexpected problems.

6.2 Routine maintenance

During the warranty period, maintenance performed on the equipment must be documented, either in the maintenance log provided by Cargotec, or in the vessel's own maintenance log. All maintenance action specified by the program belongs to one of the following categories:

1. Lubrication
2. Inspection
3. Overhaul
4. Replacement

Lubrication: Lub. Includes the following:

- Apply grease to grease nipples
- Apply lubricant or oil to surfaces to minimize friction or corrosion
- Refill or change oil to system or component

Inspection: Insp. usually involves running the equipment and includes the following:

- Check component for any damage
- Check for correct function of each component
- Check for deviant noise from each component
- Check for any abnormal vibration from rotating components
- Check for correct oil quantity
- Check paint condition on all components
- Check for leakages
- Check for corrosion
- Check lifting wire for wear

Overhaul: Ovh. includes the following:

- Remove the component from the unit
- Disassemble the component and inspect each part
- Repair if necessary:
 - Bearings
 - O-rings, gaskets and seals
 - Wear of mechanical parts due to friction
 - Hydraulic valves fittings and hoses
 - All fasteners (bolts, nuts, washers etc)
- Clean all components before reassembling the assembly
- Replace or repair components as required, before reassembling the assembly
- Repair any paint damage

Replace: R. REPLACE DOES NOT MEAN REPAIR. Replace includes the following:

- Remove original component and exchange with a new component.

6.3 Periodic Maintenance Program

M= Month, Y= Year, W= Week, H= Hours **Note 3**

Cargotec's 1Y and 5Y inspections should be done in conjunction with the customer's own inspections.

PERIODIC MAINTENANCE PROGRAM					
Equipment	Lub.	Insp.	Ovhl.	R.	Action
General Inspection		1W			General inspection for hydraulic system leakages Quantity of oil, to be in top of level glass Crane functionality Emergency operation (if applicable) Accumulator oil pressure (if applicable) Check for wire damage Check for lifting equipment damage (hook etc.)
Grease nipples (General)	1M/ 100H				Apply grease to all grease nipples. Include wire sheaves, cylinders, el. motor and docking head
		3M/ 100H			Inspect for proper function, damage & corrosion. Remove excess grease.
				!	Replace if damaged
Winch/slew gear drive pinion	1M/ 100H				Apply special grease to drive pinion and ring tooth
		1Y/ 500H			Check for wear / abnormal tooth clearance
				!	Replace if damaged
Wire	3M/200H				Apply grease onto wire
		1M/ 200H			Inspect for corrosion & wear. Rub length of wire with a cloth to detect broken strands
		3M/ 100H			Inspect wire secured to winch drum. Check torque.
				!	Replace if damaged
Wire sheaves		6M/ 200H			Inspect for corrosion, wear, cracks. Check bolts. Inspect that wire sheave rotates freely
				!	Replace if damaged
Accumulators (If mounted)		6M/ 200H			Inspect general condition. Check nitrogen pressure value according to flow diagram. Use Cargotec Norway AS Manometer fill/check instrument. Check mounting bracket (bolts, nuts)
				!	Overhaul or replace if unable to hold the necessary charge. Contact Cargotec Norway AS After Sales
Cylinders		6M/ 200H			Inspect all exposed cylinder rods. Must be free from dirt, damage and other foreign contaminants. Check condition (paint, leakages, corrosion)
				!	Overhaul /replace if damaged
Winch/slew motor		3M/ 100H			Inspect for any deviant noise, vibration and leakages. Inspect valves (paint, leakages & corrosion)
				5Y	Overhaul component
				!	Replace if damaged

M= Month, Y= Year, W= Week, H= Hours

PERIODIC MAINTENANCE PROGRAM					
Equipment	Lub.	Insp.	Ovhl.	R.	Action
Winch/slew Gearbox		3M/ 100H			Inspect for deviant noise and vibration. Tighten bolts if required. Inspect general condition (paint, leakages & corrosion)
		3M/ 50H			Check gear oil and brake oil level
	1Y				Change oil
			5Y		Overhaul component
				!	Replace if damaged
Electric Motor and hydraulic pump.		3M/ 200H			Inspect for deviant noise, vibration, corrosion & leakages
			5Y		Overhaul the component
				!	Replace if damaged
Sliding surfaces	3M/200H	3M/ 200H			Check for wear, apply grease, adjust sliding pads
Hydraulic hoses, fittings, couplings		6M/ 200H			Check condition of hoses
				!	Replace if damaged
Hydraulic valves		6M/ 200H			Inspect for deviant noise or function. Inspect condition (paint, leakages & corrosion) Apply grease to the valve levers (the rubber cap must be removed)
				!	Replace if damaged
Mechanical components		6M/ 200H			Inspect the entire crane for structural damage. Check for corrosion. Inspect paint condition
				!	Replace component if damaged
Hydraulic system oil	1Y				Take oil sample for analysis. Note 1 Change if necessary
Hydraulic oil filter		6M/ 500H			Inspect filter for abnormal contamination. Note 2
				6M/ 500H	Replace
Bolts and nuts		6M/ 500H			Inspect all bolts and nuts on crane. Foundation bolts especially

Note 1: From time to time and at least once a year, we recommend checking the hydraulic system oil. Regular checking of oil will help keep the hydraulic system in excellent condition and reduce the need to change the oil. We recommend that a sample of the oil is sent to a recognised laboratory (oil company) or to Cargotec Norway AS who will perform an analysis and evaluate the quality of the oil. The result of the analysis will decide whether the oil will have to be replaced or processed.

Note 2: This inspection action is added to ensure that special *attention is paid to the quality / possible contamination of the oil* when the filter is replaced.

Note 3: Time intervals listed are generally based on equipment's running time. Equipment or parts of it exposed to weather, chemicals, heat, vibrations or other impacts apart from normal wear and tear from running will require additional attention.

6.4 Standard inspection form for cranes

Inspection report №:
Machine no: G5005-1

(Use a copy of this report for each inspection)

	Inspection date	Checked by	Condition	Actions taken
General Inspection				
Grease nipples				
Winch / slew gear pinion				
Wire and hook				
Wire sheaves				
Accumulator (if mounted)				
Cylinders				
Winch / slew motor				
Winch / slew gear box				
Electromotor / hydr. pump				
Sliding surfaces (if any)				
Hydraulic hoses, fittings etc.				
Hydraulic valves				
Hydraulic system oil				
Hydraulic oil filter				
Bolts and nuts				



This report should be copied, filled in for each service interval and filed onboard

6.5 Inspection log

MONTHLY INSPECTIONS: G5005

<i>Crane type:</i> <i>HMC 1610 LK 50-17</i> <i>(MR9)</i> <i>Inspection report №:</i>	Inspection date	Checked by	Condition	Actions taken
<i>Check №:</i> 1				
2				
3				
4				
5				
6				
7				
8				
9				
10				
11				
12				
13				
14				
15				
16				
17				
18				
19				
20				
21				
22				
23				
24				
25				
26				
27				
28				
29				
30				



Maintenance log!

During the warranty period, all maintenance described in this user manual must be carried out and documented. Either in the enclosed maintenance log or in the vessel's maintenance log. Lack of documented maintenance violates and forfeits the warranty.

6.6 Lubrication instructions

The following Lubrication Specification System (LSS) papers are attached in the following pages.

Lubrication nipples in general	LSS. No. 01
Wire	LSS. No. 02
Slew gear box	LSS. No. 03
Winch	LSS. No. 04 & LSS. No. 04 BW
Hydraulic system oil	LSS. No. 05
Drive pinions	LSS. No. 08
HM standard grease	LSS. No. 11

Maintenance system for Hydramarine products		MacGREGOR MacGREGOR Hydramarine AS
Doc. ID. : LSS-01 nipples.docx	Rev. / date : 01 / 23.09.03	Page: 1 of 1

HYDRAMARINE STANDARD LUBRICATION SPECIFICATION	
Specification no. :	
LSS-01	
Lubrication equipment:	
LUBRICATION NIPPLES IN GENERAL	
General Instruction:	
<p>Operate the equipment while applying grease. Use enough grease so that excess grease can be seen on the bearings.</p> <p>For location of grease nipples, refer lubrication chart for the actual product.</p>	
General Lubrication Specification:	
DIN 51502 ISO 6743-09	KP 2 K 30 ISO-L-XCCEB 2
Suppliers Lubrication Specification:	
Texaco Castrol	MULTIFAK EP2 SPHEEROL SX 2/ LMX grease
Comments / notes :	

Maintenance system for Hydramarine products		MacGREGOR MacGREGOR Hydramarine AS
Doc. ID. : LSS-02 wire.docx	Rev. / date : <u>02 / 14.11.05</u>	Page: <u>1 of 1</u>

HYDRAMARINE STANDARD LUBRICATION SPECIFICATION	
Specification no. : LSS- 02	
Lubrication equipment: WIRE AND SLIDING SURFACES	
General Instruction: Apply grease to wire and sliding surfaces according to the maintenance program	
General Lubrication Specification: Grease for wire and sliding surfaces in offshore and marine environment	
Suppliers Lubrication Specification: Texaco FLOATCOAT/ TEXCLAD PREMIUM 2 Castrol SPHEEROL SX2	
Comments / notes :	

Maintenance system for Hydramarine products		MacGREGOR MacGREGOR Hydramarine AS
Doc. ID. : LSS-03 slew gear BRE.docx	Rev. / date : <u>02 / 29.11.04</u>	Page: <u>1 of 4</u>

HYDRAMARINE STANDARD LUBRICATION SPECIFICATION	
Specification no. :	
LSS- 03 BRE	
Lubrication equipment:	
SLEW GEAR BOX	
General Instruction:	
<p>Specified in lubrication instruction next pages.</p> <p>For location of lubrication points, refer lubrication chart for the actual product.</p>	
General Lubrication Specification:	
DIN 51517 / 3 CLP ISO VG 150	
Suppliers Lubrication Specification:	
Texaco Castrol	MEROPA 150 ALPHA 150
Comments / notes :	
<p>The lubrication specification above is valid for gear unit.</p> <p>For brake unit, see instructions next page.</p>	

Maintenance system for Hydramarine products		MacGREGOR MacGREGOR Hydramarine AS
Doc. ID. : LSS-03 slew gear BRE.docx	Rev. / date : <u>02 / 29.11.04</u>	Page: <u>2 of 4</u>

Lubrication Instruction:

GEAR LUBRICATION INSTRUCTION

General

- In-line units mounted horizontally and right-angle units mounted in the B3B and B3C position; fill to centre line.
- Any unit mounted in positions not covered by the above: completely fill with oil.

Check the table next page for correct plug positions. Check oil filling carefully in all cases. Extension pipes may be installed to facilitate checking of oil level, depending on the type of mounting. For vertical mounting an header oil tank can be supplied.

Continuous working temperature must not exceed 90° C.

OIL CHANGES.

Oil intervals may be modified, depending on actual operating conditions. During oil change, we recommend that the inside of the gear case is flushed out with flushing fluid recommended by lubricant manufacturer. Oil should be changed when hot to prevent build up of sludge deposit. It is advisable to check oil level at least once per month. If more than 10 % of total oil capacity has to be added, check for oil leaks. Do not mix oils of different types even of the same make. Never mix mineral and synthetic oils. Pay attention to oil and gear temperature during oil change, to avoid the risk of scalding. Be conscious of the pollution hazard due to the oil.

DISC BRAKES TYPE FL.

For lubrication of the brake plates we recommend to use mineral oils, heat and aging resistant, having viscosity ISO VG 32. **See LSS-05.** Hydraulic oil are normally suitable. The hydraulic fluid in the motor and the brake release is normally suitable.

The brake lubricant levels are the same as the gear unit to which they are attached; that is half-full if horizontal and completely filled if vertical.

The brake and gear units are separately lubricated, and it is essential that both oil-levels are checked independently.

For brake oil specification see LSS05







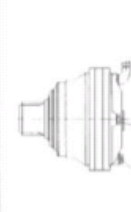
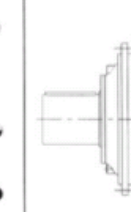
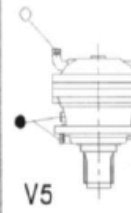
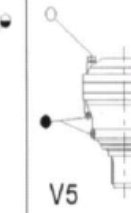

Maintenance system for Hydramarine products		MacGREGOR MacGREGOR Hydramarine AS
Doc. ID. : LSS-03 slew gear BRE.docx	Rev. / date : 02 / 29.11.04	Page: 3 of 4

Lubrication Instruction:

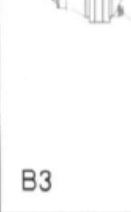
FOR SLEW /WINCH-DRIVE GEARBOXES “RPR”.

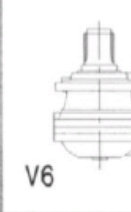
The main bearing (nearest to the output pinion) from the serie 065/150/250/400 and 600 is grease lubricated. Take care to fill the bearing compartment with grease before starting. This is done by pumping grease into the grease-nipple until the grease comes out the main bearing which is protected by a so called “NILOS” ring. Grease should be completely exchanged every 1000 hours or six months, whatever occurs first. The grease exchange is done pumping grease into the grease nipple until clean grease is coming out of the gearbox main bearing.

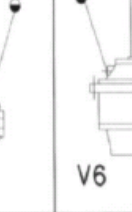
For grease specification see LSS01

010-090	150-800	Serie PDL	010-090	150-800	Serie PDL
					
B3	B3	B3	V5	V5	V5
					
V6	V6	V6	V6	V6	V6
					

Maintenance system for Hydramarine products		MacGREGOR MacGREGOR Hydramarine AS
Doc. ID. : LSS-03 slew gear BRE.docx	Rev. / date : 02 / 29.11.04	Page: 4 of 4



Maintenance system for Hydramarine products		MacGREGOR MacGREGOR Hydramarine AS
Doc. ID. : LSS-04 winch BW.docx	Rev. / date : 01 / 23.09.03	Page: 1 of 2

HYDRAMARINE STANDARD LUBRICATION SPECIFICATION					
Specification no. : LSS- 04 BW					
Lubrication equipment: WINCH					
General Instruction: Specified in lubrication instruction next pages.					
General Lubrication Specification: DIN 51517 / 3 CLP ISO VG 150					
Suppliers Lubrication Specification: <table style="width: 100%; border: none;"> <tr> <td style="width: 50%;">Texaco</td> <td style="width: 50%;">MEROPA 150</td> </tr> <tr> <td>Castrol</td> <td>ALPHA 150</td> </tr> </table>		Texaco	MEROPA 150	Castrol	ALPHA 150
Texaco	MEROPA 150				
Castrol	ALPHA 150				
Comments / notes:					

Maintenance system for Hydramarine products		MacGREGOR MacGREGOR Hydramarine AE
Doc. ID. : LSS-04 winch BW.docx	Rev. / date : 01 / 23.09.03	Page: 2 of 2

Lubrication Instruction:

WINCH LUBRICATION INSTRUCTION

General

The system consists of to separate chambers, planetary gear unit and multi-disk/motor unit. The planetary gear unit is gained through the plugs shown in the diagram below. The multi-disk brake and motor is lubricated by the circulating hydraulic motor oil.

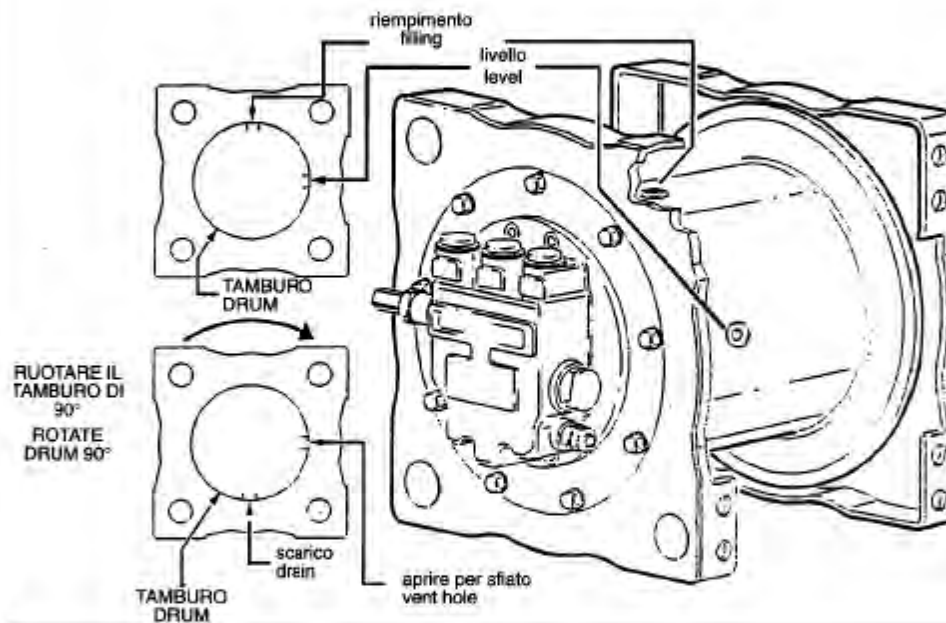

Oil changes.

Oil should be changed when hot to prevent build up of sludge deposit. Do not mix oils of different types even of the same make. Never mix mineral and synthetic oils.

Maintenance system for Hydramarine products		MacGREGOR MacGREGOR Hydramarine AS
Doc. ID. : LSS-04 winch gear BRE.docx	Rev. / date : <u>01 / 23.09.03</u>	Page: <u>1 of 3</u>

HYDRAMARINE STANDARD LUBRICATION SPECIFICATION				
Specification no. : LSS- 04 BRE				
Lubrication equipment: WINCH GEAR BOX				
General Instruction: Specified in lubrication instruction next pages. For location of lubrication points, refer lubrication chart for the actual product.				
General Lubrication Specification: DIN 51517 / 3 CLP ISO VG 150				
Suppliers Lubrication Specification: <table style="width: 100%; border: none;"> <tr> <td style="width: 50%;">Texaco</td> <td>MEROPA 150</td> </tr> <tr> <td>Castrol</td> <td>ALPHA 150</td> </tr> </table>	Texaco	MEROPA 150	Castrol	ALPHA 150
Texaco	MEROPA 150			
Castrol	ALPHA 150			
Comments / notes : The lubrication specification is valid for gear unit. For brake unit, see instructions next page.				

Maintenance system for Hydramarine products		MacGREGOR MacGREGOR Hydramarine AS
Doc. ID : LSS-04 winch gear BRE.docx	Rev. / date : <u>01 / 23.09.03</u>	Page: <u>2 of 3</u>

Lubrication Instruction:

GEAR LUBRICATION INSTRUCTION

General

- In-line units mounted horizontally and right-angle units mounted in the B3B and B3C position; fill to centre line.
- Right angle units in position B3D: fill them completely in case of intermittent duty.
- Any unit mounted in positions not covered by the above: completely fill with oil.

Check the table next page for correct plug positions. Check oil filling carefully in all cases. Extension pipes may be installed to facilitate checking of oil level, depending on the type of mounting. For vertical mounting an header oil tank can be supplied.

Continuous working temperature must not exceed 90° C.

OIL CHANGES.

Oil intervals may be modified, depending on actual operating conditions. During oil change, we recommend that the inside of the gear case is flushed out with flushing fluid recommended by lubricant manufacturer. Oil should be changed when hot to prevent build up of sludge deposit. It is advisable to check oil level at least once per month. If more than 10 % of total oil capacity has to be added, check for oil leaks. Do not mix oils of different types even of the same make. Never mix mineral and synthetic oils. Pay attention to oil and gear temperature during oil change, to avoid the risk of scalding. Be conscious of the pollution hazard due to the oil.

DISC BRAKES TYPE FL.

For lubrication of the brake plates we recommend to use mineral oils, heat and aging resistant, having viscosity ISO VG 32. See LSS-05. Hydraulic oil are normally suitable. The hydraulic fluid in the motor and the brake release is normally suitable.

The brake lubricant levels are the same as the gear unit to which they are attached; that is half-full if horizontal and completely filled if vertical.

The brake and gear units are separately lubricated, and it is essential that both oil-levels are checked independently.

For brake oil specification see LSS05













Maintenance system for Hydramarine products		MacGREGOR MacGREGOR Hydramarine AS
Doc. ID : LSS-04 winch gear BRE.docx	Rev. / date : <u>01 / 23.09.03</u>	Page: <u>3 of 3</u>

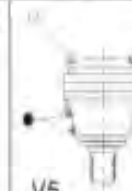

Lubrication Instruction:

FOR SLEW /WINCH-DRIVE GEARBOXES "RPR".

The main bearing (nearest to the output pinion) from the serie 065/150/250/400 and 600 is grease lubricated. Take care to fill the bearing compartment with grease before starting. This is done by pumping grease into the grease-nipple until the grease comes out the main bearing which is protected by a so called "NILOS" ring. Grease should be completely exchanged every 1000 hours or six months, whatever occurs first. The grease exchange is done pumping grease into the grease nipple until clean grease is coming out of the gearbox main bearing.

For grease specification see LSS01

010-090	150-800	Serie PDL	010-090	150-800	Serie PDL
					
					
B3	B3	B3	V5	V5	V5
			V6	V6	V6

 TAPPO SCARICO OLIO
DRAIN PLUG
  TAPPO LIVELLO OLIO
OIL LEVEL PLUG
  TAPPO CARICO E SFIATO OLIO
BREATHER AND FILLING PLUG

Maintenance system for Hydramarine products		MacGREGOR MacGREGOR Hydramarine AS
Doc. ID. : LSS-05 Hydraulic oil.docx	Rev. / date : <u>02 / 26.10.05</u>	Page: <u>1 of 1</u>

HYDRAMARINE STANDARD LUBRICATION SPECIFICATION		
Specification no. :		
LSS- 05		
Lubrication equipment:		
HYDRAULIC SYSTEM OIL		
General Instruction:		
Oil levels and quantity specified in the maintenance procedure in the User manual		
General Lubrication Specification:		
DIN 51524 / 3 HVLP	ISO VG 68	For temp >+35 °C
DIN 51524 / 3 HVLP	ISO VG 46	For temp >+20 °C <+35 °C
DIN 51524 / 3 HVLP	ISO VG 32	For temp >+10 °C <+20 °C
DIN 51524 / 3 HVLP	ISO VG 22	For temp <+10 °C **)
Suppliers Lubrication Specification:		
Texaco	RANDO OIL HDZ68	For temp >+35 °C
	RANDO OIL HDZ46	For temp >+20 °C <+35 °C
	RANDO OIL HDZ32	For temp >+10 °C <+20 °C
	RANDO OIL HDZ22	For temp <+10 °C
Castrol	HYSPI AWH 68	For temp >+35 °C
	HYSPI AWH 46	For temp >+20 °C <+35 °C
	HYSPI AWH 32	For temp >+10 °C <+20 °C
	HYSPI AWH 15	For temp <+10 °C
Comments / notes :		
**) For low temperature operation below +20 °C, special arctic oil is recommended. Please contact relevant supplier for exact specification.		
Ex.:		
Statoil:	HYDRAULIC OIL 131	For temp >+40 °C < +65 °C

Maintenance system for Hydramarine products		MacGREGOR MacGREGOR Hydramarine AS
Doc. ID. : LSS-08 Drive pinion.docx	Rev. / date : <u>04 / 21.11.2007</u>	Page: <u>1 of 1</u>

HYDRAMARINE STANDARD LUBRICATION SPECIFICATION	
Specification no. : LSS-08	
Lubrication equipment: DRIVE PINIONS — MANUAL LUBRICATION	
General Instruction: Use a brush to apply grease to all tooth flanks of pinions and gear ring. Relubricate in accordance with the maintenance program. For location of pinions, refer to the lubrication chart for the product in question.	
Approved Suppliers' Lubrication Specifications: Kluber: Kluberplex AG 11-462 (HMS) Norsk Industriolje AS: Omega 73 Hydro Texaco / YX Energy / Chevron: Texclad 2 (HSE/HMS)	
General Lubrication Specifications: DIN 51502: MF 2C-10/KF 2C-10 ISO 6743-09: ISO-L-X AAIB2	
Typical properties: Soap type: Calcium Consistency: NLGI 2 Recommended temperatures: -30→110 °C (for Kluberplex AG 11-462) Recommended temperatures: -3→150 °C (for Omega 73) Recommended temperatures: -10→60 °C (for Texclad 2) Solid lubricants: Solid lubricant content (min 20%)	
Comments / notes: Note: The colour of AG 11-462 is white. Omega73 and Texclad 2 is black	

Maintenance system for Hydramarine products		MacGREGOR MacGREGOR Hydramarine AS
Doc. ID. : LSS-11 Hydramarine standard grease.docx	Rev. / date : 0 / 29.11.2006	Page: 1 of 2

HYDRAMARINE STANDARD LUBRICATION SPECIFICATION	
Specification no. : LSS-11	
Lubrication equipment: HYDRAMARINE STANDARD GREASE	
General Instruction: <p>If possible, operate the equipment while applying grease.</p> <p>Initial assembly and manual relubrication: inject grease until excess grease can be seen on the bearings.</p> <p>Assembly of rolling bearings: fill bearing completely with grease.</p> <p>For location of grease nipples, refer to the lubrication chart for the product in question.</p>	
Approved Suppliers' Lubrication Specifications: <p>Statoil: Statoil Chassis Grease (HMS) Greaseway CaH 92 (HMS)</p> <p>Hydro Texaco / Chevron: Novatex Heavy EP 2 (HMS)</p>	
General Lubrication Specifications: <p>ISO 6743-9: L-XBCIB2 / L-XCCHB2</p> <p>DIN 51502: KP2K-20 / KP2K-30</p>	

Maintenance system for Hydramarine products		MacGREGOR MacGREGOR Hydramarine AS
Doc. ID. : LSS-11 Hydramarine standard grease.docx	Rev. / date : 0 / 29.11.2006	Page: 2 of 2

Typical properties:

	Calcium	Method
Soap type:	2	NLGI
Consistency:	Mineral	
Oil type:		
Base oil viscosity at 40 °C:	1300 mm ² /s	ISO 12058*
Base oil viscosity at 100 °C:	106 mm ² /s	ISO 12058*
Recommended temperatures:	-20→120 °C	
Long polymer (“tacky”) additives:	Yes	
Extreme pressure (EP) additives:	Yes	
Solid lubricants:	No	

*) Base oil viscosity applies to the final mixed oil including long polymer additives.

Comments / notes:

- **LSS-11 may be used instead of LSS-01 and LSS-09 for all Hydramarine applications *except* gearboxes, electric motors and pulse encoders. Greases according to LSS-11 are miscible with greases according to LSS-01 and LSS-09, so changing to LSS-11 does not require cleaning out old grease.**
- **This is not a “general purpose” grease. For example, it is not suitable for lubrication of high-speed bearings. Use only where specified.**

6.7 Lubrication chart with lubrication points

Lubrication is the first of the four maintenance categories and directly extends the lifespan of the equipment. As a form of preventive maintenance aimed at protecting the equipment, lubrication must be carried out according to the periodic maintenance program.

The following Lubrication Points drawing gives an overview of the "what" and "where" of lubrication for all parts of the equipment. The drawing refers to numbered LSS documents. These "Lubrication Specification Sheets" are standard documents explaining lubricant details.

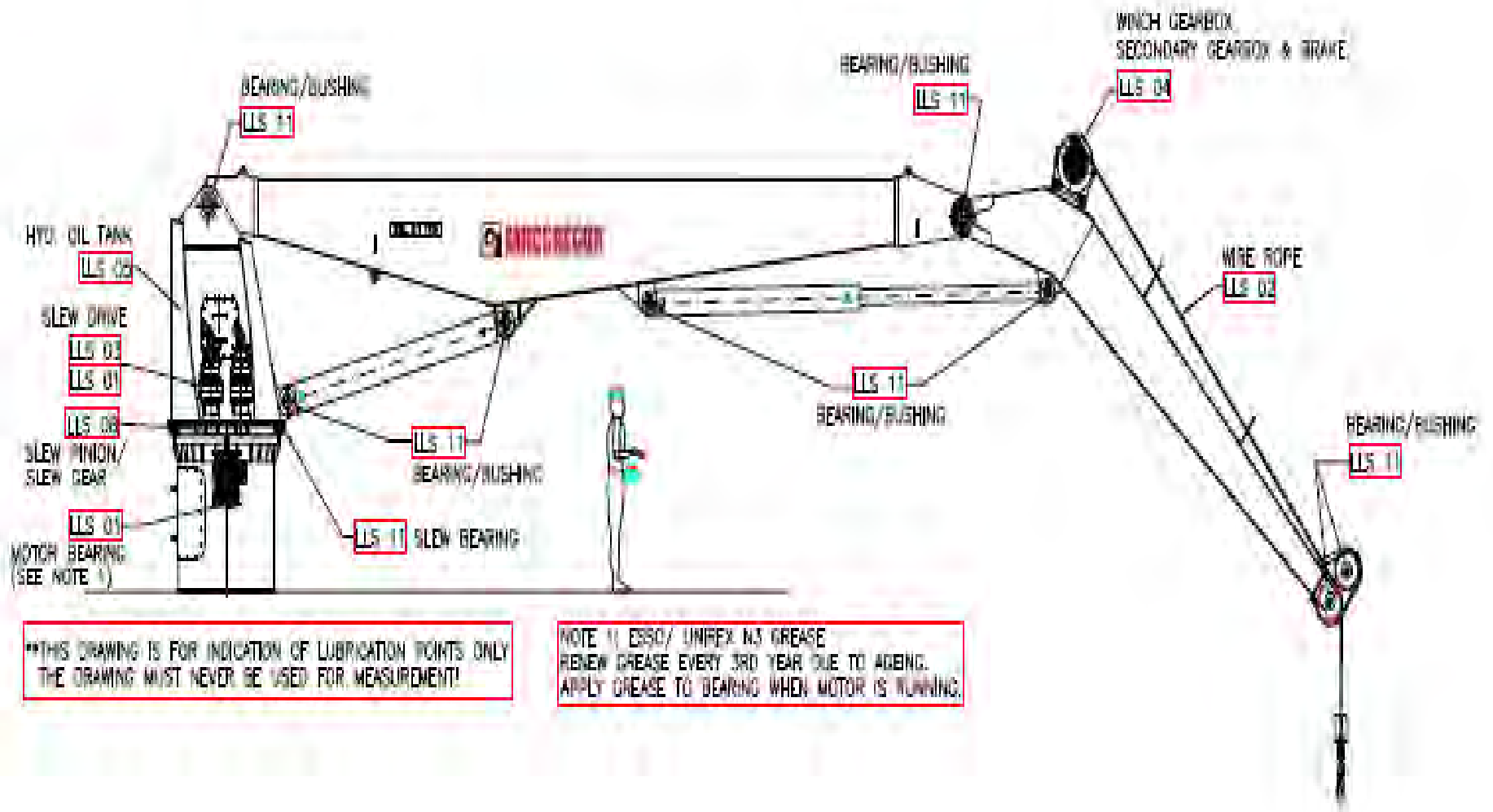

****THIS DRAWING IS FOR INDICATION OF LUBRICATION POINTS ONLY
THE DRAWING MUST NEVER BE USED FOR MEASUREMENT!**

**NOTE 1) ESSO/ UNIFEX N3 GREASE
RENEW GREASE EVERY 3RD YEAR DUE TO AGING.
APPLY GREASE TO BEARING WHEN MOTOR IS RUNNING.**

6.8 Change of oil filter

This system is equipped with a high quality drain filter (MH11). The filter element (MH12) shall be changed every 500 hours use, or more often if required.

How to change the filter element:

1. Ensure there is no pressure on the return line
2. Open the cover and remove the filter-element
3. Dismount the split pin and the crown nut
4. Remove the filter element and replace
5. Remove the magnet from the lock bolt and clean
6. Mount the magnet on the lock-bolt and screw up the nut
7. Mount the new filter element with spring and spring retainer
8. Unscrew the crown nut until the split pin hole becomes visible and mount the split-pin
9. Mount the cartridge into the house and put on the spring at the cover side
10. Unscrew the cover. Ensure the O-ring is clean and undamaged

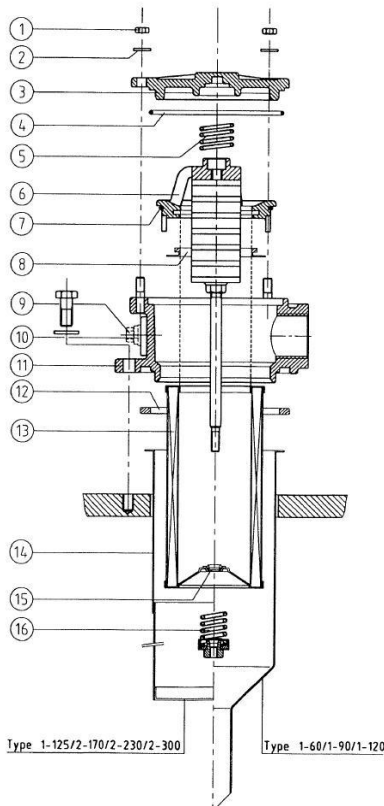

ITEM NUMBER TEIL NUMBER NUMÉRO DE PART	DESCRIPTION
1	Nut
2	Washer
3	Filter cover
4	Cover seal
5	Top spring
6	Insert
7	Insert seal
8	By-pass seal
9	Plug M10x1
10	Bonded seal
11	Filter head
12	Housing seal
13	Filter element
14	Funnel/diffuser
15	Element seal
16	By-pass set

Breather filter

Replace breather filter (MH10, 3/4") every 2nd year unless extremely polluted air has entered the tank for a longer period of time.

6.9 Checking the hydraulic system oil

From time to time and at least once a year, we recommend checking the hydraulic system oil. Regular checking of oil will help keep the hydraulic system in excellent condition and reduce the need to change the oil.

We recommend that a sample of the oil be sent to a recognised laboratory (oil company) or to **Cargotec Norway AS** who will perform an analysis and evaluate the quality of the oil.

The result of the analysis will decide whether the oil will have to be replaced or processed.

7 COMPONENT PARTS LIST

7.1 Component parts list

7.1.1 Mechanical part list:

Reference to Drawing № : C.1610.188.AS01 & C.1610.188.AS02

POSITION	ITEM NO.	QTY.	DESCRIPTION
AS01-06	S132457	45m	WIRE ROPE
AS01-07	11003445	1	HOOK UP STOPPER
AS01-08	10019301	1	SHACKLE
AS01-09	10019800	1	SWIVEL HOOK
AS01-XX	10002398	2	HOOKSTOP CONNECTOR WIRE
AS01-XX	S131808	2	D-SHACKLE
AS01-11	A.01.5125.190.B	1	MAIN CYLINDER BOLT
AS01-12	11009796	2	DIST. RING
AS01-13	A.01.5125.180.C	1	MAIN CYLINDER BOLT
AS01-14	11009796	2	DIST. RING
AS01-15	A.01.5100.180	2	KN. CYL. BOLT
AS01-16	11009794	4	DIST. RING
AS01-19	11009793	1	MAIN JIB BOLT
AS01-20	11009792	1	KN. JIB. BOLT
AS02-01	S132459	54	SOC HD CAP BOLT
AS02-01P	S132748	3	SOC HD CAP BOLT
AS02-02	S132460	57	HEX NUT
AS02-03	10000782	114	WASHER
AS02-04	S132461	3	SOC HD CAP BOLT
AS02-05	10000782	3	WASHER
AS02-06	S132462	60	SOC HD CAP BOLT
AS02-07	10000782	60	WASHER
AS02-08	10002274	2	SLEW BEARING
AS02-09	11000516	2	SLEW GEAR
AS02-10	10009538	2	MOTOR ADAPTOR
AS02-11	10009539	2	SLEW PINION
AS02-13	10009661	42	SOC HD CAP BOLT
AS02-14	11003777	42	WASHER
AS02-28	10002794	2	COUPLING HUB
AS02-29	10002793	1	COUPLING HUB FLEXIBLE ELEMENT
AS02-33	10000560	1	GASKET
AS02-40	S130618	1	SOC SET SCREW
AS02-41	S130614	1	SOC SET SCREW

S131777 - Slew gear & Pinion

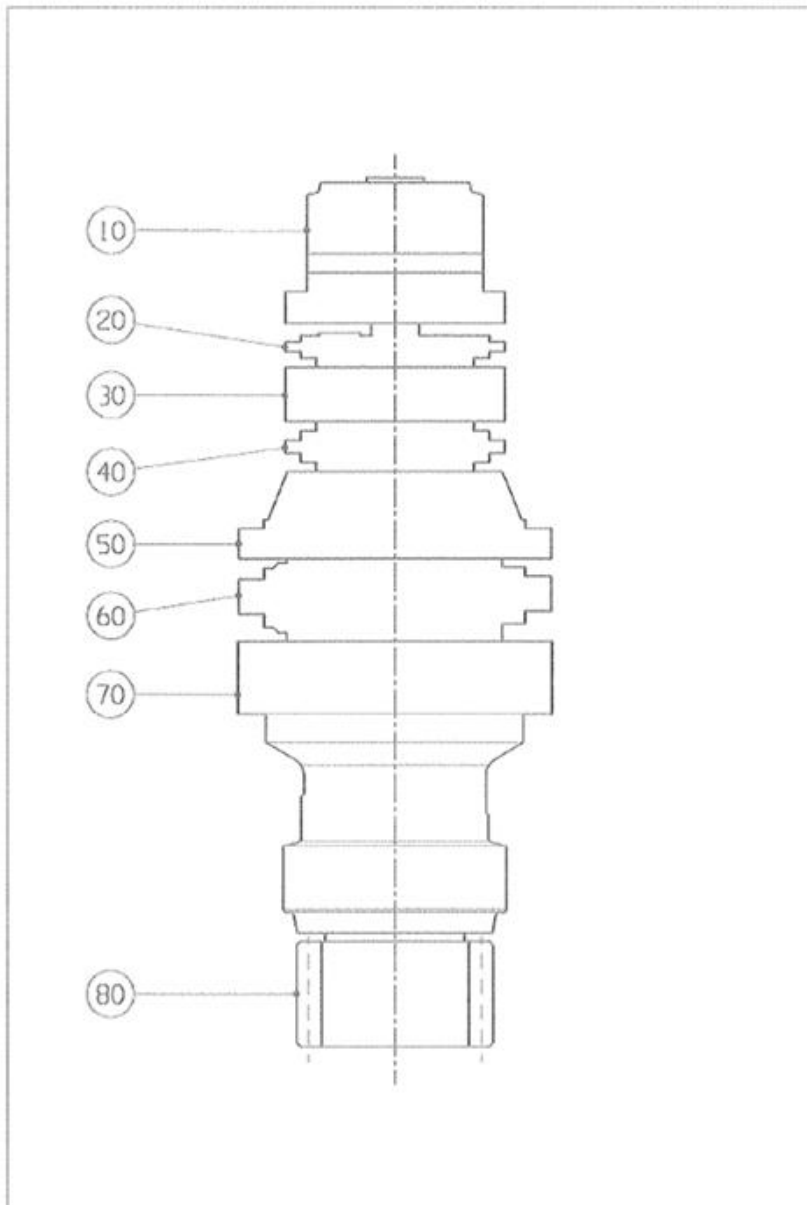

Slewing Gearbox Component Part List

Pos.	Description	Quantity
10	Brake	1
20	Reduction stage	1
30	Intermediate flange	1
40	Reduction stage	1
50	Intermediate flange	1
60	Reduction stage	1
70	Output support	1
80	Pinion	1

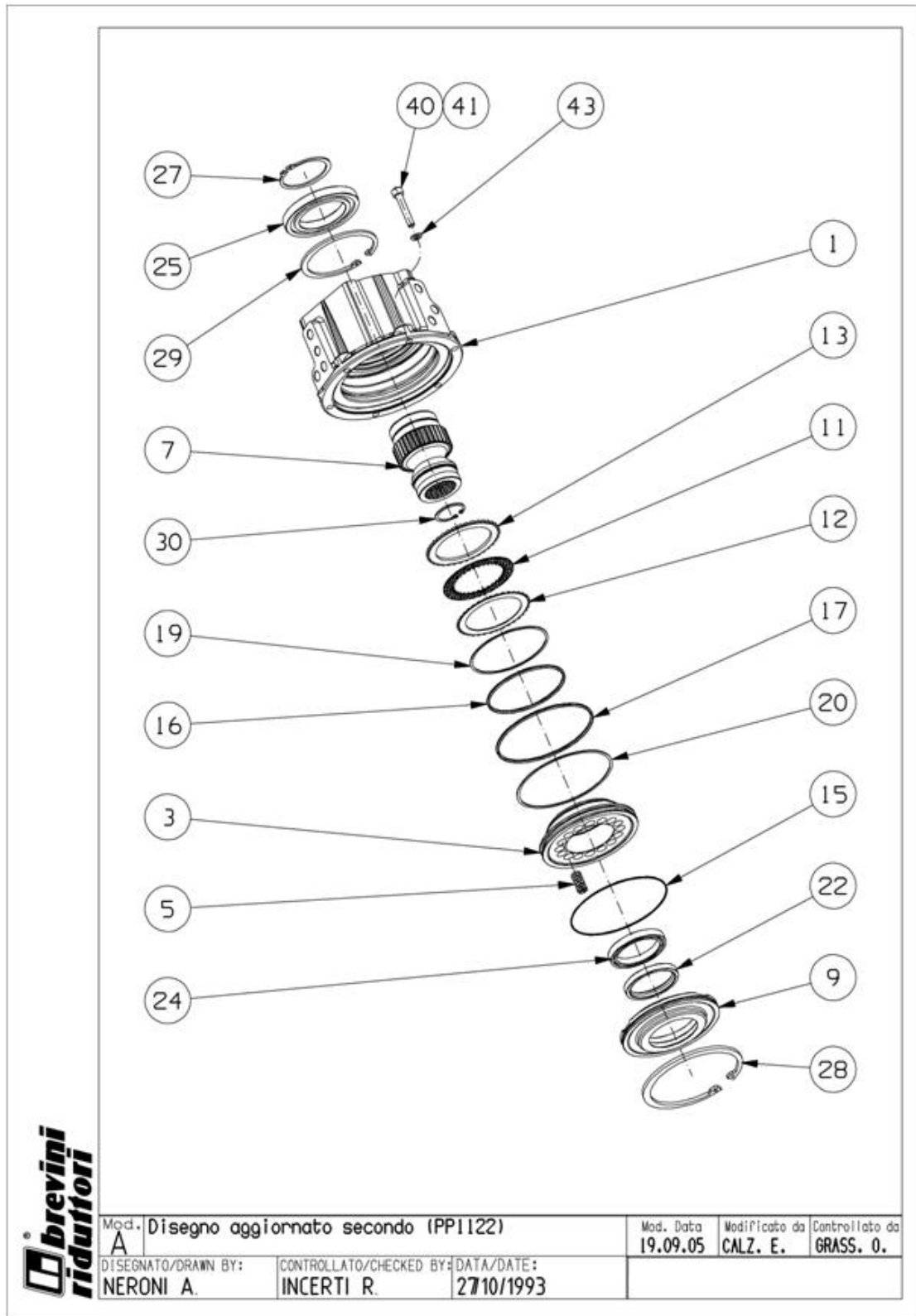

Slew Brake Exploded View

Brake Component Part List

Pos.	Description	Quantity
1	CASING	1
3	PISTON	1
5	SPRING	14
7	SHAFT	1
9	COVER	1
11	DISK	6
12	DISK	6
13	DISK	1
15	O-RING	1
16	O-RING	1
17	O-RING	1
19	BLOCKING RING	1
20	BLOCKING RING	1
22	OIL SEAL	1
24	BEARING	1
25	BEARING	1
27	CIRCLIP	1
28	CIRCLIP	1
29	CIRCLIP	1
30	CIRCLIP	1
40	SCREW	6
41	SCREW	6
43	WASHER	6

7.1.2 Hydraulic part list:

Reference to Drawing №: C.1610.188.HF01

POSITION	ITEM NO.	QTY.	DESCRIPTION
JH02	10000529	1	COUNTER BALANCE VALVE
JH04	10000529	2	COUNTER BALANCE VALVE
JH05	10001434	1	PRESSURE RELIEF VALVE
SH01	11007733	2	HYRAULIC SLEW MOTOR
SH02	11015311	2	COUNTER BALANCE VALVE
SH03	11015214	16	M8 BOLT
SH04	10000418	1	RESTRICTOR CHECK VALVE
SH05	10000420	1	RESTRICTOR VALVE
MH01	11007764	1	HYDRAULIC PUMP
MH02	10001810	1	SAE FLANGE
MH03	10000341	4	SOC. HD CAP SCREW
MH04	10001815	1	SAE FLANGE O-RING
MH05	10006130	1	SAE FLANGE GASKET
MH06	11015766	1	CONTROL VALVE
MH07	10003411	1	LEVEL GAUGE W/ THERMOMETER
MH08	10000413	1	LEVEL GAUGE
MH09	10000425	1	BALL VALVE
MH10	10000008	1	BREATHER FILTER
MH11	10007276	1	RETURN FILTER
MH12	10000010	1	RETURN FILTER ELEMENT
MH13	10001433	1	MINIMESS TEST COUPLING
MH14.1	10002648	1	QUICK COUPLING, MALE
MH14.2	S144381	1	DUCT CAP
MH14.3	10002649	1	QUICK COUPLING, FEMALE
MH14.4	S144380	1	DUST PLUG
MH15	10001434	1	PRESSURE RELIEF VALVE
MH16	S144783	1	SOLENOID VALVE + LEVER CONTROL
MH17	10000632	1	SUBPLATE
MH18	10001868	1	HAND PUMP
MH19	11003151	1	ISOLATION VALVE
MH20	10000494	1	CHECK VALVE
MH21	S142528	1	BALL VALVE
WH01	11004169	1	HOISTING WINCH
WH03	10000530	1	SHUTTLE VALVE
WH04	10000418	1	RESTRICTOR CHECK VALVE
WH05	10000428	1	BALL VALVE
WH06	10006247	1	CHECK VALVE
WH07	10002290	1	HOOKSTOP VALVE
WH08	10003985	1	SEQUENCE VALVE

7.1.3 Electrical part list:

Reference to Electrical Drawing №: Refer Electric Diagram attached in 8.1.

POSITION	ITEM NO.	QTY.	DESCRIPTION
RCC97	S122981	1	RADIO CONTROL CABINET
ES400	S122982	1	STARTER CABINET
RCC97.1	S122985	1	RADIO REMOTE CONTROLLER
JB35	10009460	1	JUNCTION BOX
JB35-11	11013814	2	END BRACKET
JB35-11.1	11013815	1	CONNECTOR MARKER
JB35-XA	10009482	5	TERMINAL BLOCK
JB35-XA.1	11013807	1	TERMINAL BLOCK
JB450	11001808	1	SLIPRING
M01	S122991	1	ELECTRIC MOTOR
OP12	11001258	1	REMOTE START/STOP BOX
OP12.1	11001257	1	PROTECTION SHEILD
W192	11007993	5	CABLE
W193	11007993	1	CABLE
W250.XY1A	11001929	1	CONNECTOR
W251.XY1B	11001929	1	CONNECTOR
W252.XYV2	11001929	1	CONNECTOR
W253.XYV2	11001929	1	CONNECTOR
W254.XYV3	11001929	1	CONNECTOR
W255.XYV3	11001929	1	CONNECTOR
W256.XYV4	11001929	3	CONNECTOR
W257.XYV4	11001929	2	CONNECTOR
W260.XY1	11011236	1	CABLE





7.2 Hydraulic hose list

Item no:	HM art. no.	Note
	C 1610 188 HF01	
001	8G5120102536537	-
002	8G5120195536537	-
004	8G5160290536537	-
005	8M5060215333334	-
006	8M5060215333334	-
007	8M5060209333334	-
008	8M5060153333333	-
009	8M5060143333334	-
010	8M5060142333334	-
011	8M5060156333335	-
012	8M5060139333334	-
013	8M5060153333333	-
014	8M5060147333334	-
015	8M5060078333333	-
016	8M5060168333335	-
017	8M5060148333333	-
018	8M5060081333333	-
019	8M5060140333334	-
020	8M5060161333335	-
021	8M5060079333333	-
022	8M5060216333334	-
110	8M5060027333335	-
115	8M5060032333335	-
121	8G5120195536537	-
123	8G5120142536536	-
124	8G5120142536536	-
125	8G5120147536537	-
126	8G5120153536537	-
127	8G5120116536537	-
128	8G5120111536537	-
129	8M5080105333334	-
130	8M5060026333334	-
131	8G5120145536538	-

132	8G5120154536538	-
133	8M5080161333335	-
137	8M5060127333334	-
140	8M5060078333334	-
141	8G5120088536537	-
142	8M5080066333334	-
201	8M5080196333335	-
202	8M5060176333335	-
301	8M5060205333334	-
302	8G5120207536537	-
303	8G5120152536536	-
304	8G5120152536536	-
305	8G5120134536537	-
306	8G5120143536537	-
307	8G5120111536538	-
308	8G5120111536538	-
309	8M5080050333335	-
310	8M5080108333335	-
311	8M5080145333334	-
501	8G5120202536537	-
502	8G5120205536537	-
503	8G5120130536536	-
504	8G5120130536536	-
507	8G5100119536537	-
508	8G5100115536537	-
509	8G5100141536537	-
510	8G5100135536537	-
511	8M5040092333334	-
513	8M5040079333334	-
516	8M5080091333334	-
517	8M5080044333334	-

7.3 Ordering spare parts

All enquiries regarding service and spare parts should be directed to:

<p>Cargotec CHS Asia Pacific Pte Ltd 48 Tuas Road Singapore 638500 http://www.macgregor-group.com/service</p>	
 <p>+65 6861 3922</p>	 <p>24 hours service: +47 916 89751</p>
 <p>+65 6862 4334</p>	
 <p>service.sin@cargotec.com</p>	

Always refer to actual equipment machine number (G....) for exact definition of components and service advice.

	<p><u>IMPORTANT NOTICE!</u></p> <p>During the warranty period, all necessary spare parts must be supplied by Cargotec CHS Asia Pacific Pte Ltd The use of spare parts from other suppliers violates and forfeits the warranty.</p>
---	--

8 DRAWINGS & DATA SHEETS

8.1 Project Drawings

- General arrangement drawing (GA)
- Assembly drawings (AS01)
- Hydraulic diagrams (HF01)
- Electrical diagrams

This document and all data disclosed herein or herewith are the confidential and proprietary property of MacGREGOR Hydramarine AS and are not to be used, reproduced or disclosed in whole or in part by or to anyone without the written permission of MacGREGOR Hydramarine AS.

Drawn without reference drawings to comply with NS/ISO 2768/1 tolerance class "medium".	Table to comply with GRADE B NS 470.
Rev. Description Drawn Checked Date	
0 ISSUED FOR APPROVAL	rna 18.10.10

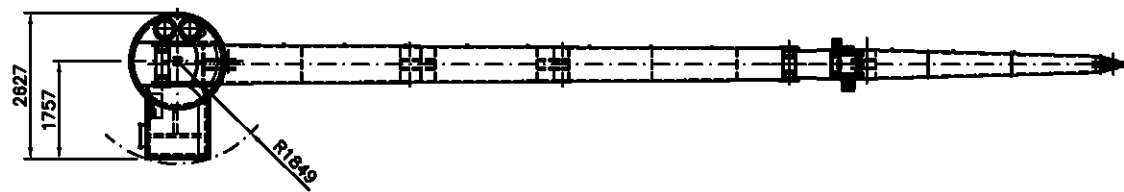
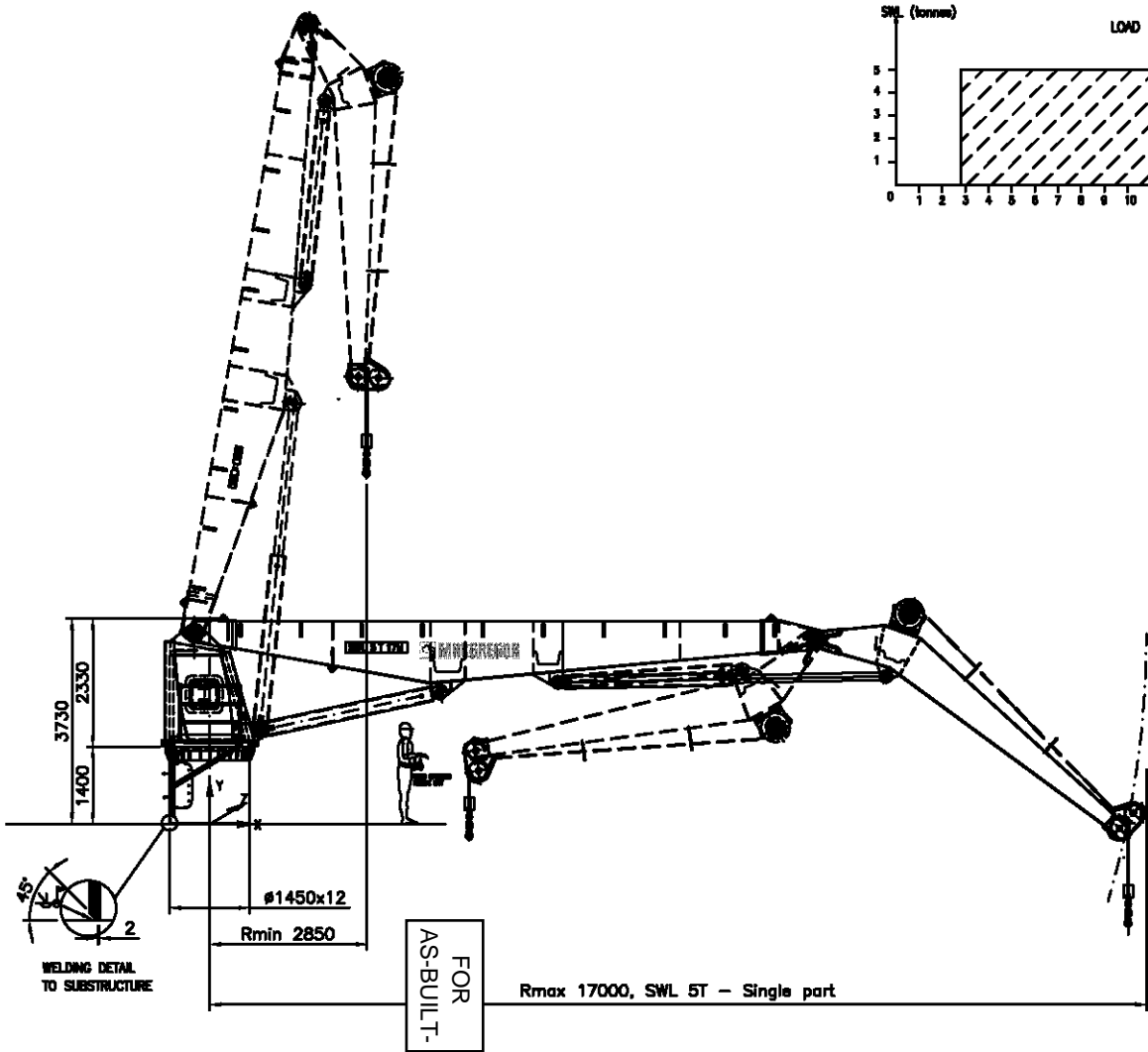
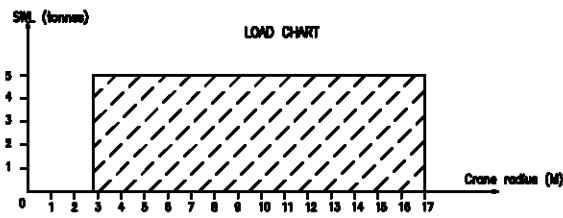

MAX. MOMENTS GIVEN ARE INCL. DYN. FACTOR 1,15 AND TRIM/LIST = 2°/5°

Mz = 1800 kNm, JIB HORIZONTAL
My = 170 kNm, JIB HORIZONTAL

Total weight approx. 13 Ton, (SWL not included)

18.10.10 Drawing No.	1:100/A3 Scale	MacGREGOR Hydramarine AS Tel: +47 41 88 88 10 Fax: +47 41 88 88 11
HMC 1810 LK 50-17(MRS) GENERAL ARRANGEMENT	C.1610.188.GA	REV. 0

THIS IS A COMPUTER AIDED DRAWING AND MUST NOT BE ALTERED MANUALLY.

This document and all data disclosed herein or hereafter are the confidential and proprietary property of MacGREGOR Hydramarine AS and are not to be used, reproduced or disclosed in whole or in part by or to anyone without the written permission of MacGREGOR Hydramarine AS.

Drawings without reference dimensions to comply with: NS/ISO 2768/1 tolerance class "medium".	Table to comply with: GRADE B NS 470.
Rev. Description 0 ISSUED FOR INFORMATION	Drawn Checked Date rna 28.11.10

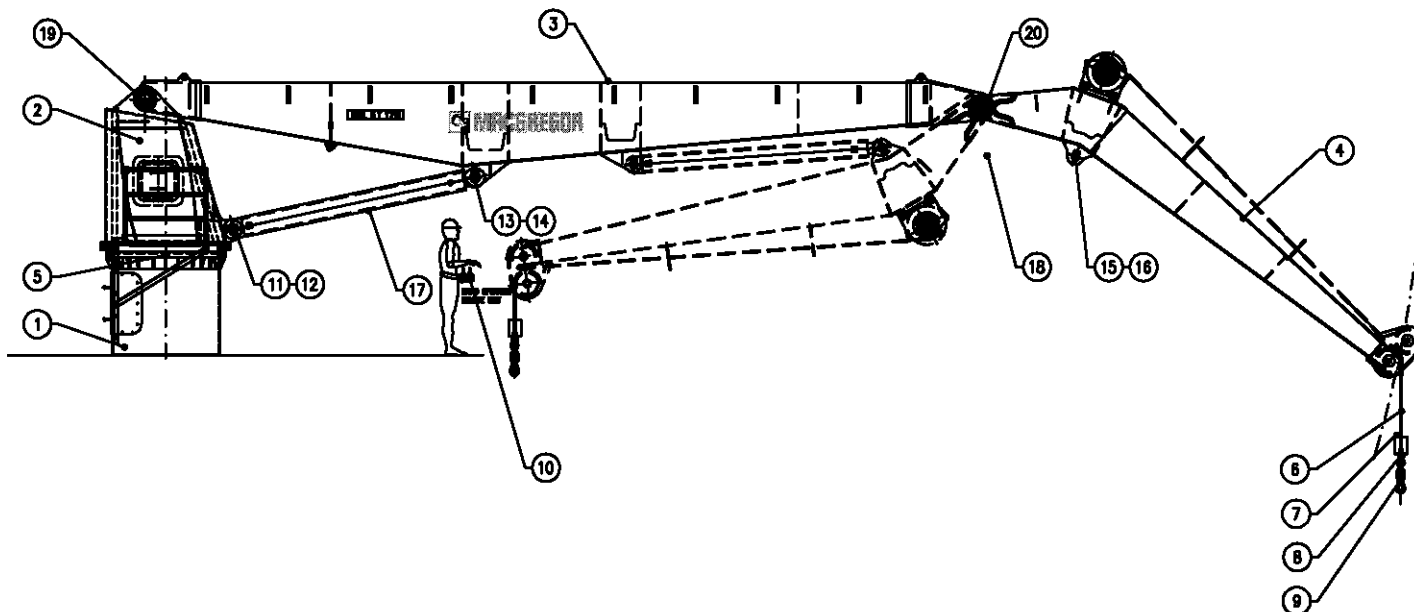

FOR
AS-BUILT-

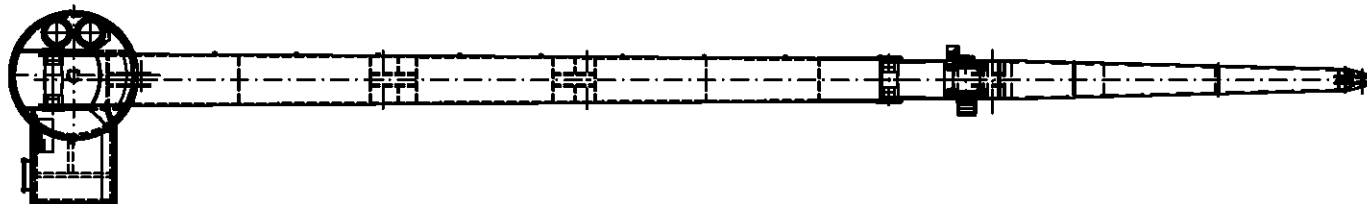

TOTAL WEIGHT 11390 kg.

No. of	Part No.	Description	Specification	Weight	Reference No.
1	25	KN JIB BOLT	Dwg. C.1610.J010.05	61	11009792
1	19	MJ. BOLT	Dwg. C.1610.J020.02	72	11009793
1	18	KN JIB CYL.	ø200/ø160 x 2605	800	FOR INFO
1	17	MAIN JIB CYLINDER	ø220/ø160 x 2640	810	FOR INFO
4	16	DIST. RING	dwg. C.1610.J008.D1 pos. 4	0.0	11009794
2	15	KN CYL. BOLT	dwg. A.01.S100.180	15	
2	14	DIST. RING	dwg. C.1610.J008.D1 pos. 1	0.0	11009796
1	13	MAIN CYL. BOLT	dwg. A.01.S125.180.C	23	
2	12	DIST. RING	dwg. C.1610.J008.D1 pos. 1	0.0	11009796
1	11	MAIN CYL. BOLT	dwg. A.01.S125.190.B	25	11009798
1	10	-A67.1	GS005-1 ELBLOCK DIAGR.	0.0	INFO
1	9	SWIVELHOOK	BSS 16-B, SWL 8.1T	15	10019800
1	8	SHACKLE	D BLUE PIN SWL 9.5T	3	10019301
1	7	WIRE STOPPER	A.01.3005.19	35	11003445
45	6	WIRE W/OPEN SP. SOCKETS	ø19, 34x7, MBL 30,7T	1,6	10019220
1	5	MOTOR/PUMP ASSY.	C.1610.188.AS02 PART LIST	1461	C1610188AS02
1	4	KN. JIB ASSEMBLY	C.1610.188.AE01	1809	C1610188AE01
1	3	MAIN JIB ASSEMBLY	C.1610.188.AD01	3135	C1610188AD01
1	2	KING ASSEMBLY	C.1610.188.AB01	1993	C1610188AB01
1	1	FOUND ASSEMBLY	C.1610.188.AA01	1056	C1610188AA01

Date: 28.11.10
 Scale: 1:750/AS

 HMC 1610 LK 50-17(MRS)
 OVERALL ASSEMBLY
 C.1610.188.AS01
 REV. 0
 THIS IS A COMPUTER AIDED DRAWING AND MUST NOT BE ALTERED MANUALLY.

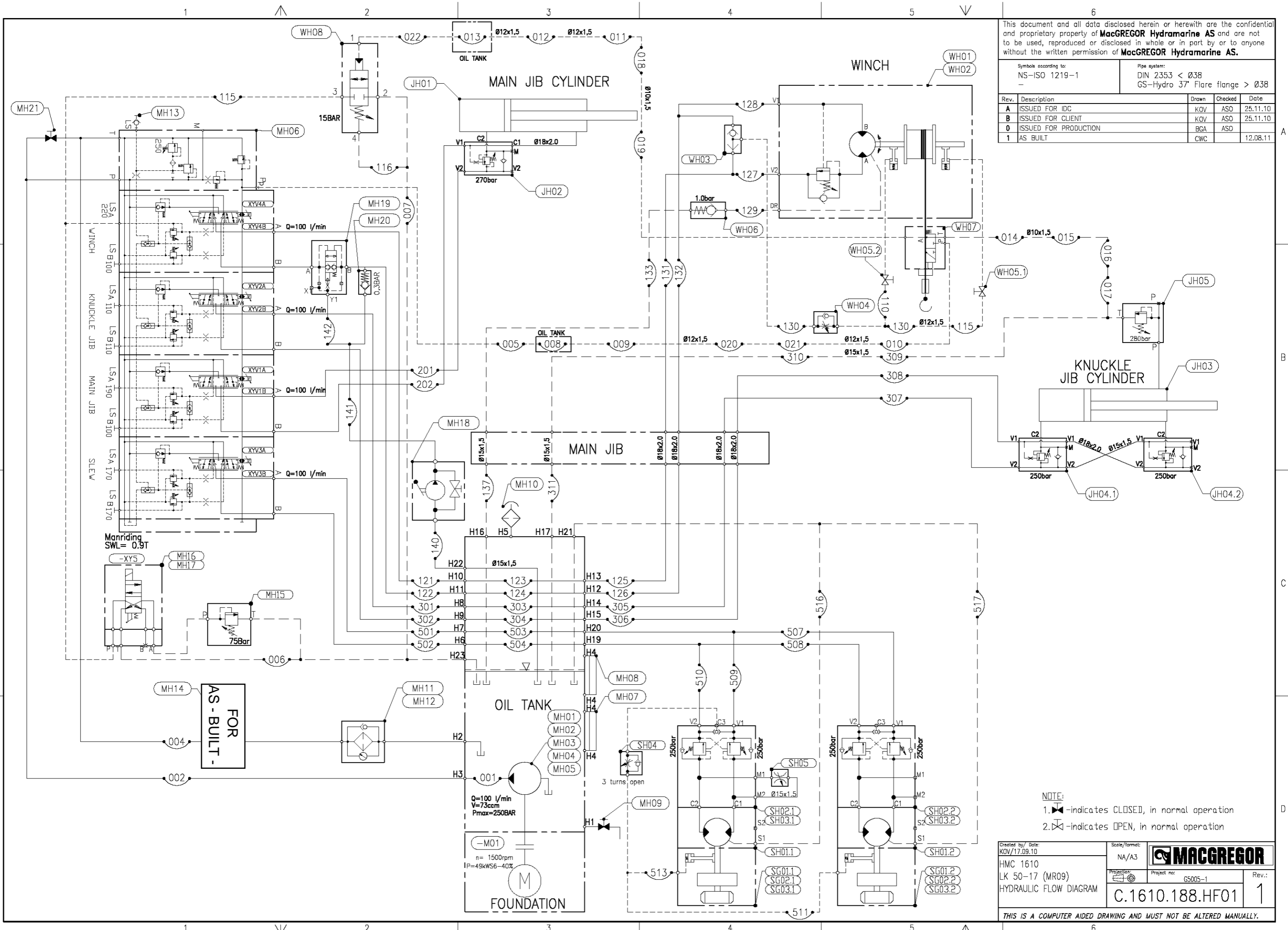

This document and all data disclosed herein or herewith are the confidential and proprietary property of **MacGREGOR Hydramarine AS** and are not to be used, reproduced or disclosed in whole or in part by or to anyone without the written permission of **MacGREGOR Hydramarine AS**.

Symbols according to: NS-ISO 1219-1		Pipe system: DIN 2353 < Ø38 GS-Hydro 37" Flare flange > Ø38		
Rev.	Description	Drawn	Checked	Date
A	ISSUED FOR IDC	KOV	ASO	25.11.10
B	ISSUED FOR CLIENT	KOV	ASO	25.11.10
Ø	ISSUED FOR PRODUCTION	BGA	ASD	
1	AS BUILT	CWC		12.08.11

- NOTE:
1. -indicates CLOSED, in normal operation
 2. -indicates OPEN, in normal operation

Created by/ Date: KOV/17.09.10	Scale/format: NA/A3	
HMC 1610	Projection: 	
LK 50-17 (MR09)	Project no: G5005-1	Rev.: 1
HYDRAULIC FLOW DIAGRAM	C.1610.188.HF01	

THIS IS A COMPUTER AIDED DRAWING AND MUST NOT BE ALTERED MANUALLY.

This document and all data disclosed herein and herewith are the confidential and proprietary property of Cargotec and are not to be used, reproduced or disclosed in whole or in part by or to anyone without written permission of Cargotec.

CUSTOMER SUPPLY

MacGREGOR SUPPLIED UNITS

Note: Cables supplier

- - - - - Cables supplied by Customer
 _____ Cables supplied by MacGREGOR
 HYDRAMARINE

GENERATOR SUPPLY

LOCATED BY CUSTOMER

LOCATED ON CRANE KING

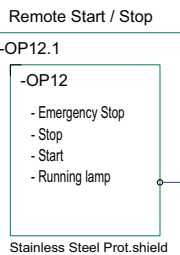

LOCATED INSIDE VESSEL

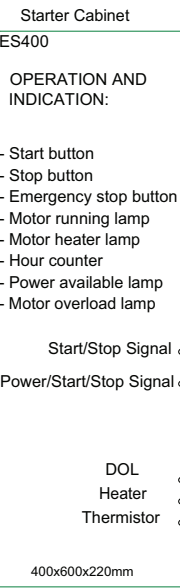

LOCATED INSIDE CRANE PEDESTAL

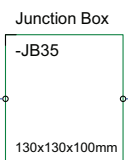

Radio Remote Cabinet

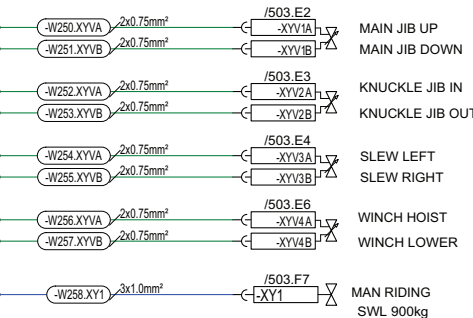
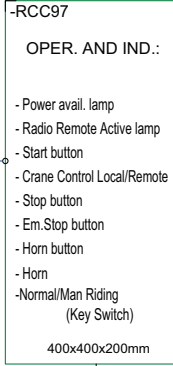

Slipping

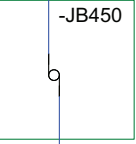

FOR AS-BUILT-

LOCATED OUTSIDE CRANE PEDESTAL

Radio Remote Consol

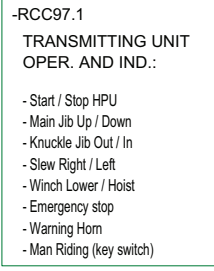

HPU Main Pump Motor

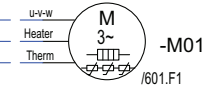

SUPPLY 3x440VAC, 60Hz
ref. Note Motor -M01



Total Power Consumption:
S1-100% duty 44 kW
S6-40% duty =65 kW

Note Motor: -M01

EL.MOTOR DATA:	
Motor type:	14BG208-4AA96-Z200L
Supply:	440 VAC / 60 Hz / 3 phz
Motor Conn. Star-Delta:	440V-Delta
Rotation Speed:	1765 rpm
Rating S1 - 100% duty:	42.5 kW / In=71 A
Rating S6 - 40% duty:	64 kW / In=106 A
Rating S6 - 25% duty:	-
Calc.Hydr.Rating:	approx.51 kW (S6-40%)
Isolation / Temp.Class:	F/IE(80)
Start Method / Current:	DOL / 6.9 x In (A)
IP-degree / Weight:	IP 56 / 230kg
Internal Heater Element:	2x40 W / 230 VAC
Std. Cable Gland Thread:	2xM50 + 2xM20
Thermistor Build In:	3PTC Thermistor

Rev.	Description	Date	Modified by	Approved
1	Changed -W191 cable	16.02.2011	RPB	THE
2	Text,motor data and power supply changed	16.11.2010	RPB	THE
0	Issued for information	01.11.2010	RPB	MSP
A	Issued for DC	01.11.2010	RPB	MSP

Furgo McClelland Marine
G5005-1
HMC 1610 LK 50-17

Drawn by	RPB
Date	11.10.2010
Project rev.	2



Main Block Diagram
Electrical Block Diagram

Dwg. No.	G5005-1	+XO	101
HLA:		Sheet rev.	2
Loc:		Next sheet	401

This document and all data disclosed herein and herewith are the confidential and proprietary property of Cargotec and are not to be used, reproduced or disclosed in whole or in part by or to anyone without written permission of Cargotec.

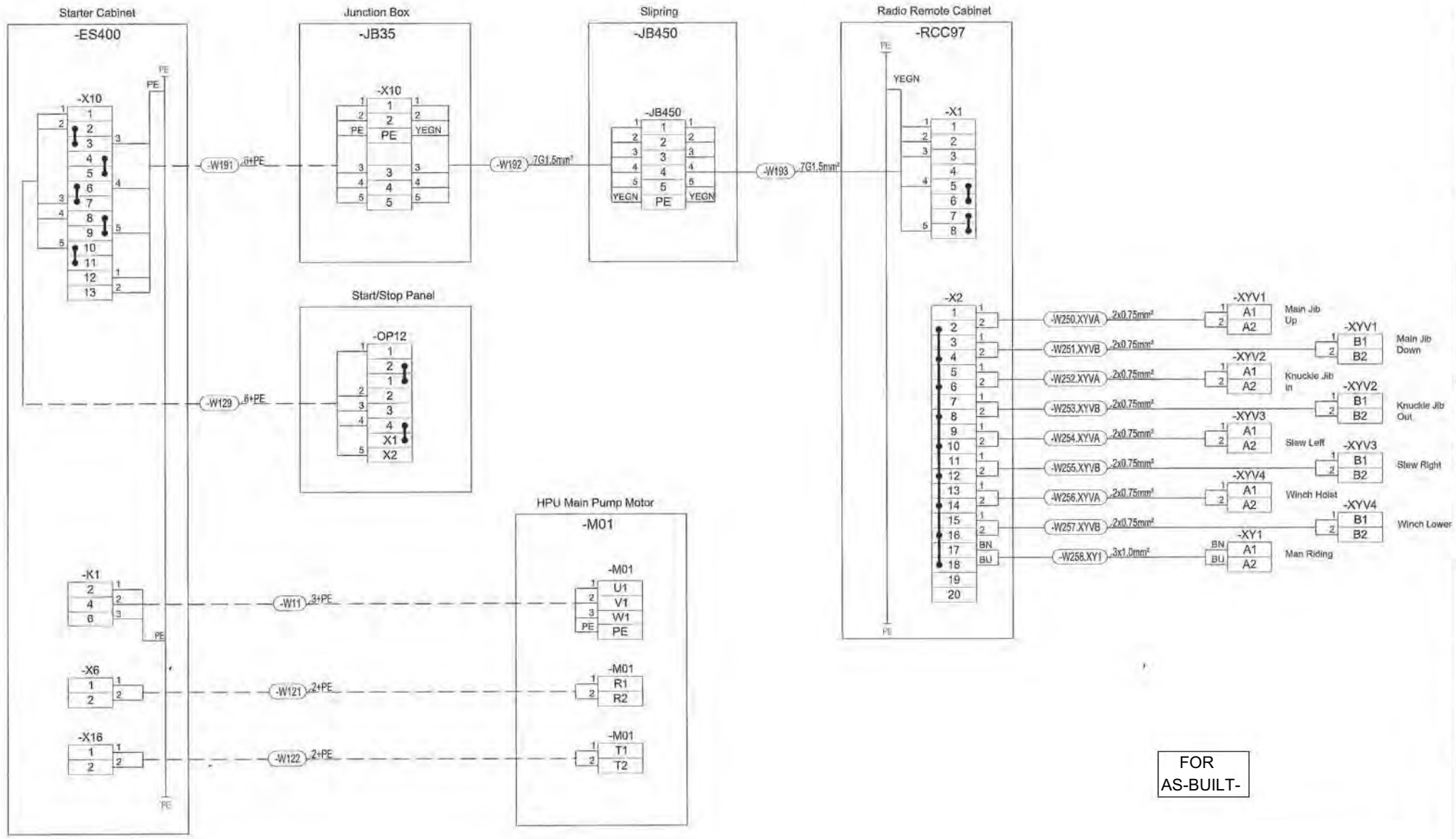

FOR AS-BUILT-

Rev.	Description	Date	Modified by	Approved
0	Issued for production	17.11.2010	RPB	THE
A	Issued for DC	16.11.2010	RPB	THE

Fergo McClelland Marine
G5005-1
HMC 1610 LK 50-17

Drawn by	RPB
Date	11.10.2010
Project rev.	2



External Wiring Diagram

Dwg. No.	G5005-1	+AP-XS	401
HLA:		Sheet rev.	0
Loc:		Next sheet	501

This document and all data disclosed herein and herewith are the confidential and proprietary property of Camptec and are not to be used, reproduced or disclosed in whole or in part by or to anyone without written permission of Camptec.

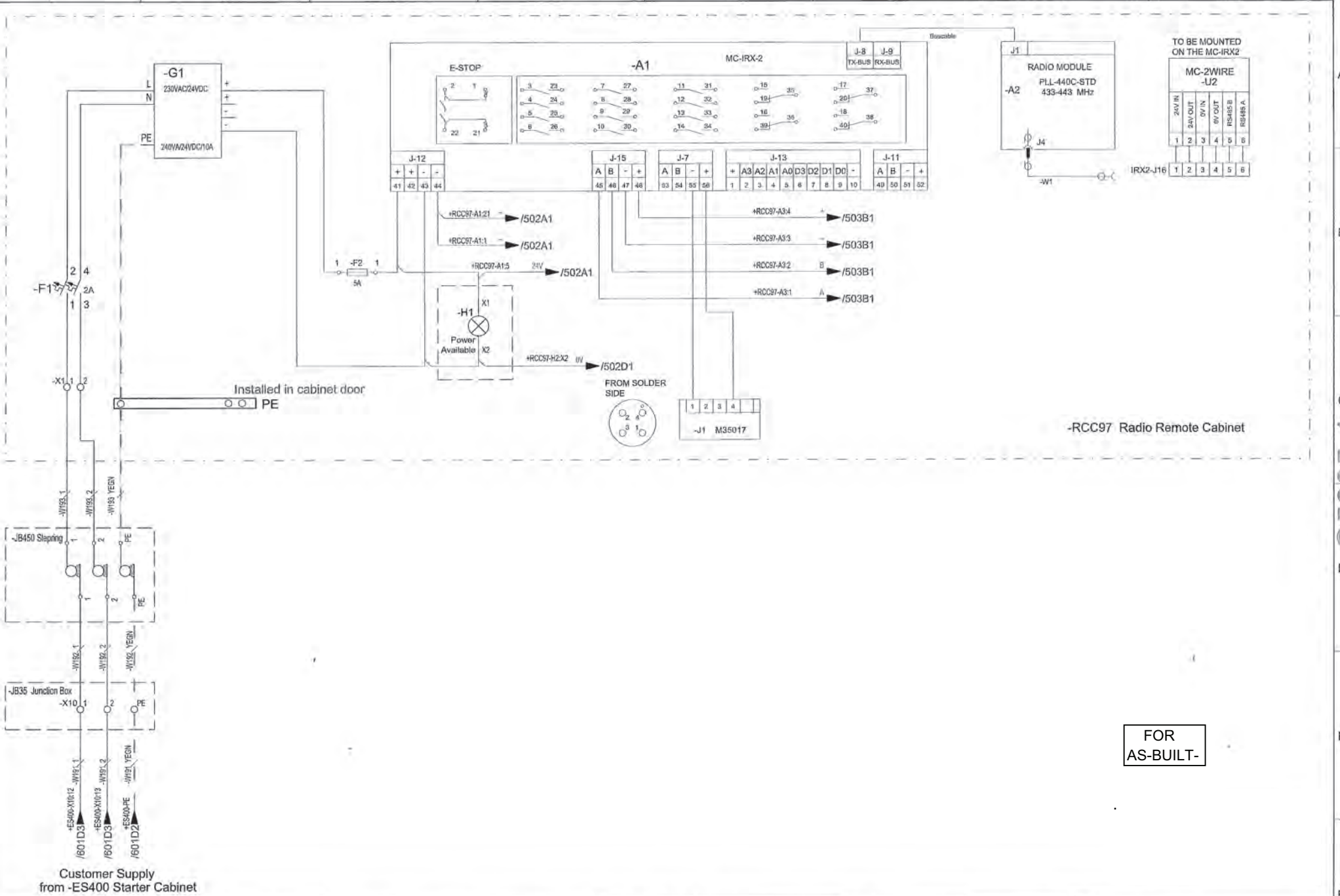

FOR
AS-BUILT-

0	Issued for production	17.11.2010	RPB	THE
A	Issued for DC	16.11.2010	RPB	THE
Rev.	Description	Date	Modified by	Approved

Furgo McClelland Marine
G5005-1
HMC 1610 LK 50-17

Drawn by	RPB
Date	11.10.2010
Project rev.	2



Loop diagram

Dwg. No.	G5005-1	+AB-XT	501
H.L.A.		Sheet rev.	0
Loc:		Next sheet	502

G5005-1

This document and all data disclosed herein and herewith are the confidential and proprietary property of Cargotec and are not to be used, reproduced or disclosed in whole or in part by or to anyone without written permission of Cargotec.

-RCC97 Radio Remote Cabinet

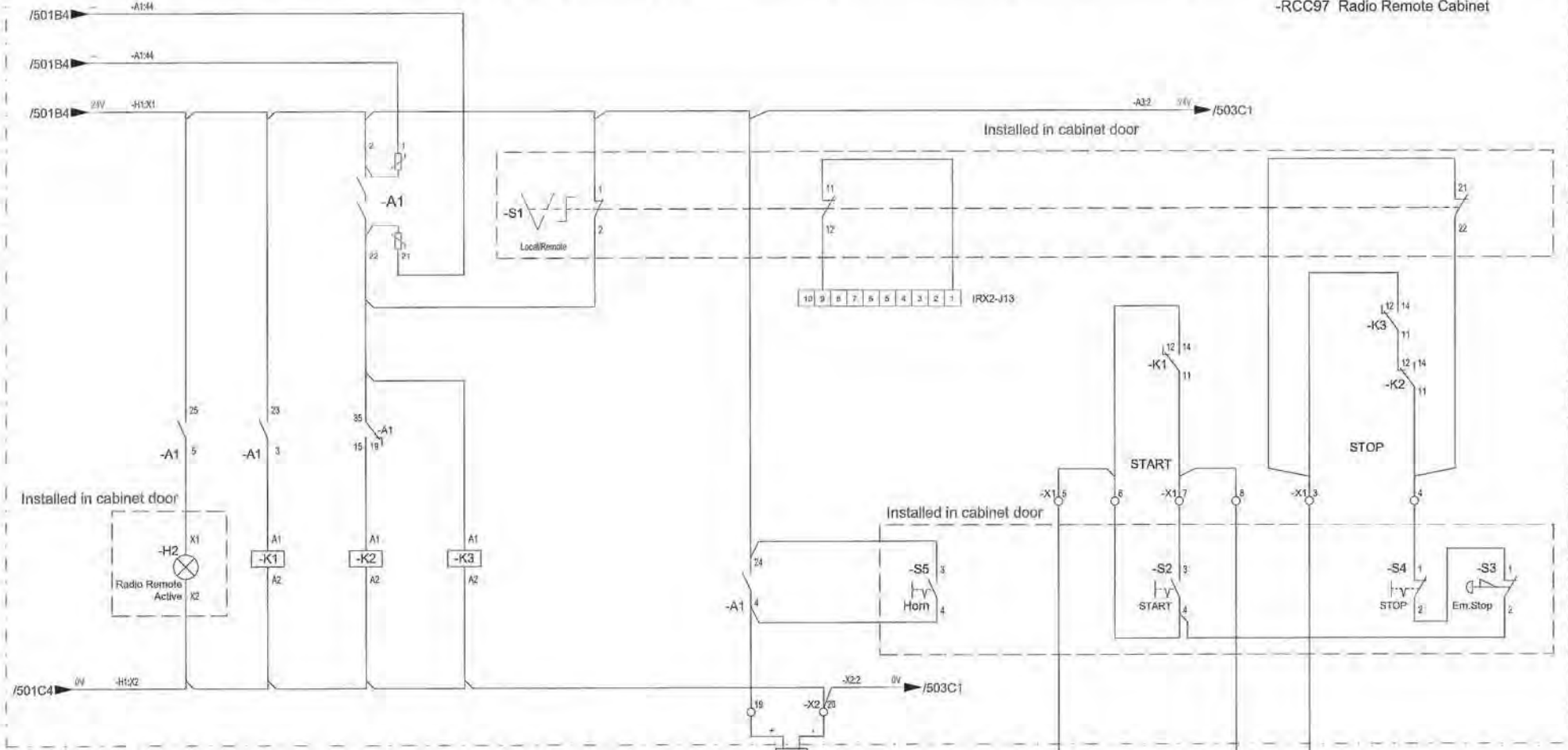

Customer Supply
from -ES400 Starter Cabinet

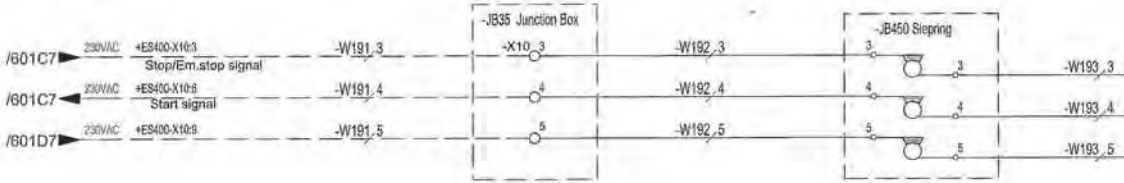

FOR
AS-BUILT-

Furgo McClelland Marine
G5005-1
HMC 1610 LK 50-17

Drawn by: RPB
Date: 11.10.2010
Project rev.: 2



Loop diagram

Dwg. No. G5005-1 +AB-XT 502
HLA: _____
Loc: _____
Sheet rev. 0
Next sheet 503

Rev.	Description	Date	Modified by	Approved
0	Issued for production	17.11.2010	RPB	THE
A	Issued for DC	16.11.2010	RPB	THE

This document and all data disclosed herein and herewith are the confidential and proprietary property of Camport and are not to be used, reproduced or disclosed in whole or in part by or to anyone without written permission of Camport.

-RCC97 Radio Remote Cabinet

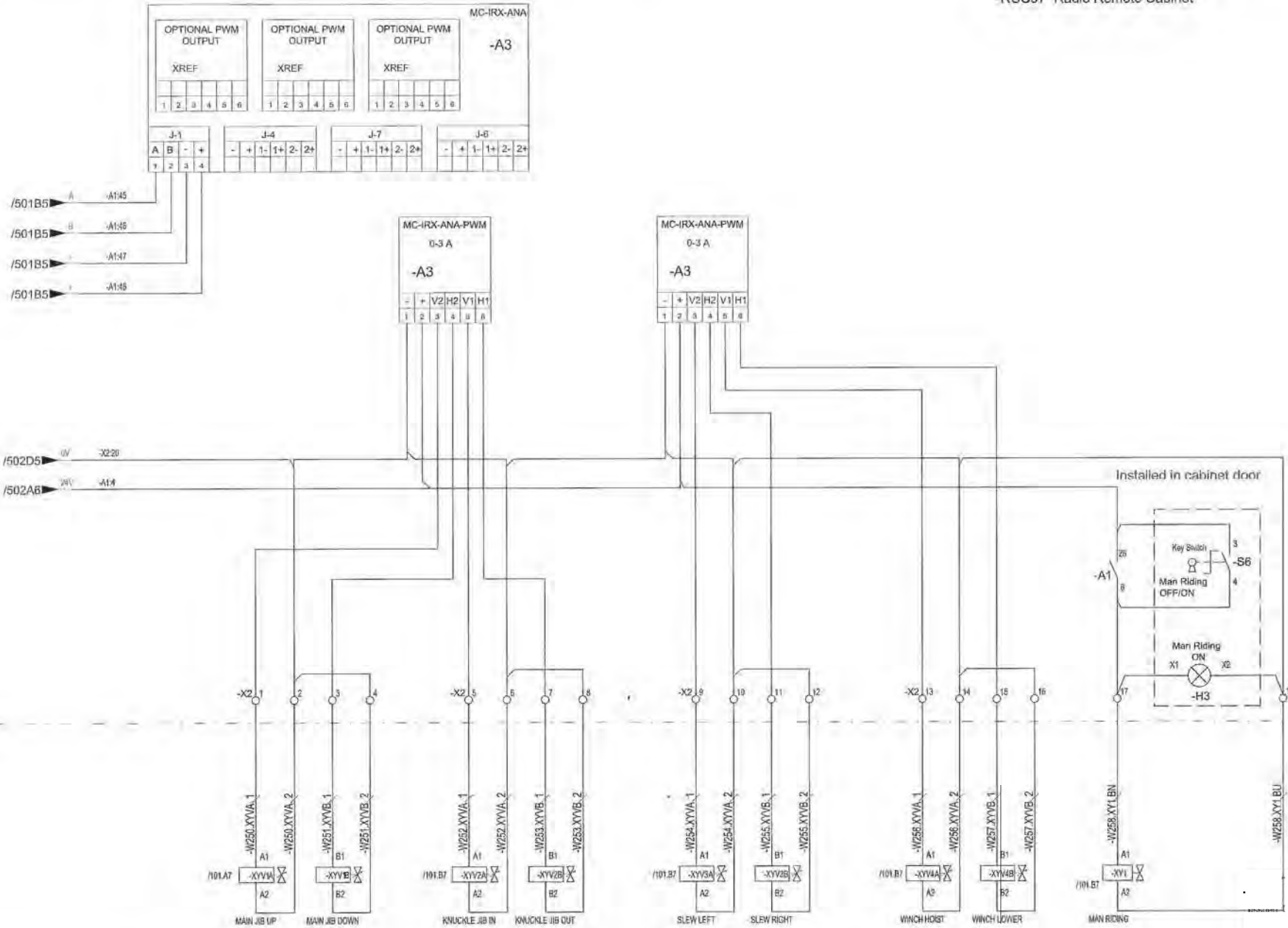

FOR AS-BUILT-

Furgo McClelland Marine
G5005-1
HMC 1610 LK 50-17

Drawn by RPB
Date 11.10.2010
Project rev. 2



Loop diagram

Dwg. No. G5005-1 +AB-XT 503
HLA: _____
Loc: _____
Sheet rev. 0
Next sheet 601

Rev.	Description	Date	Modified by	Approved
0	Issued for production	17.11.2010	RPB	THE
A	Issued for DC	16.11.2010	RPB	THE

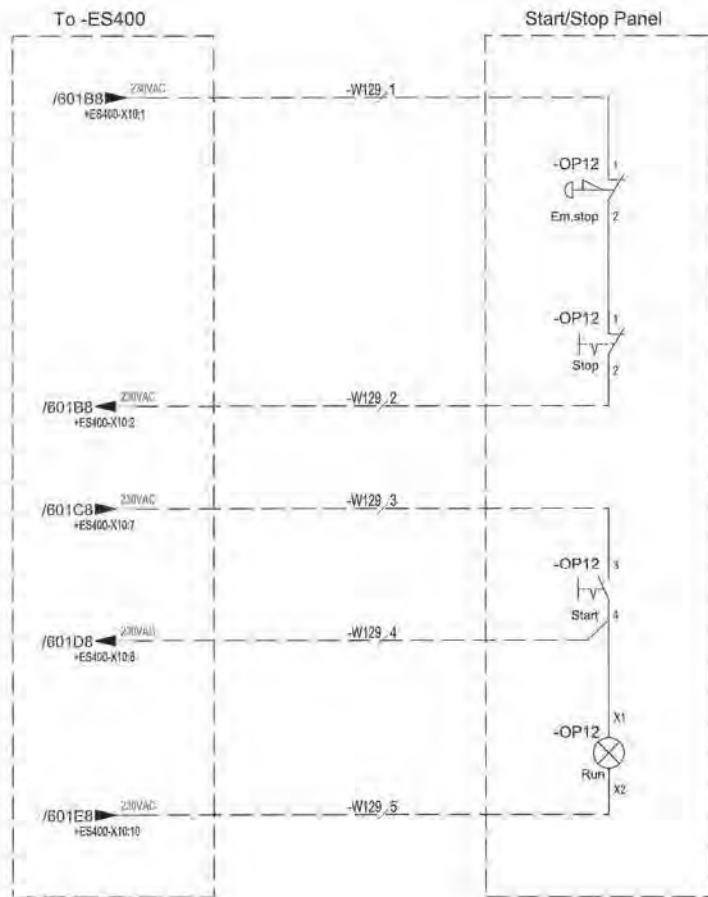

FOR
AS-BUILT-

Rev.	Description	Date	Modified by	Approved
0	Issued for production	17.11.2010	RPB	THE
A	Issued for DC	16.11.2010	RPB	THE

Furgo McClelland Marine
G5005-1
HMC 1610 LK 50-17

Drawn by	RPS
Date	11.10.2010
Project rev.	2

MacGREGOR
MacGREGOR Hydramarine AS
Tel.: +47 91 88 80 00 * Fax: +47 36 01 87 01

Loop diagram
-OP12

Dwg. No.	G5005-1	+AP-XT	602
HILA:		Sheet rev.	0
Loc:	+OP12	Next sheet	701