



29 September 2009
(Revised 14 October 2009)

MKH
OPN: 2239722
O2E Task No.: 509555/515959

Caterpillar Marine Power Systems
Power Systems Marketing Division
3701 State Road 26 E
Lafayette, IN 47905

Attention: Mr. Dwight Heffernan:

Subject: **"HYS298"**
Hyundai Heavy Ind.,
Compliance with NOx Technical Code of Annex VI of MARPOL 73/78
Engine Family: 3400CP1350&1800&2100
Caterpillar Model: **3412C**, Performance Spec.: 0K-2777
Engine Serial No.: **38S25392**
Engine Rating: 567 kW @ 2100 RPM
C1 Cycle: Variable Speed and Variable Load Auxiliary Engine Application
Technical File for 3400C Marine Engine @ 1350 & 1800 & 2100 RPM (30 pp. each)

Gentlemen:

We have your e-mail of **13 October 2009** electronically resubmitting the Technical File for the member engine as listed therein on the above subject and with regard thereto have to advise that we have reviewed the Technical File in accordance with the requirements of the IMO Annex VI of MARPOL 73/78, Resolution 2 of the 1997 MARPOL Conference, "Technical Code on Control of Emission of Nitrogen Oxides from Marine Diesel Engines" and the Technical File has been found to be in compliance with the aforementioned Resolution.

The assigned ABS approval reference for this engine is:

Engine Serial No. **38S25392** **C1 Cycle** **ABSHS-NTC-1049-0004-00198**

The Certificate for this engine will be issued by ABS Chicago Survey Office on satisfactory completion of the respective Pre-Certification Survey.

The subject Technical File submitted, appropriately stamped to indicate our review, is being returned electronically through the ABS FTP site. An original copy of the Technical File is to accompany each engine throughout its service life. Copies of any subsequent engine emission related "Modification

AMERICAS DIVISION

ABS PLAZA, 16855 NORTHCHASE DRIVE, HOUSTON, TX 77060 USA

TEL: 1-281-877-6000

FAX: 1-281-877-6001

EMAIL: ABS-amer@eagle.org

WEBSITE: www.eagle.org



MKH

OPN: 2239722

O2E Task No.: 509555/515959

Caterpillar Marine Power Systems
29 September 2009 (Revised 14 October 2009)
Page 2/2

Letters” and associated “Change Sheets” are to be submitted to ABS Houston Technical Office for review.

Our invoice to cover the cost of this expedited review will follow including ABS Chicago’s issuance of the Certificate with NOx Technical Code. Please forward your remittance as per the instructions on the invoice.

If we may be of further assistance, do not hesitate to contact Michael Haendler at 281-877-6587 by phone or 281-877-6795 by telefax. Please refer to O2E Task No.:509555/515959, when responding to this correspondence.

Very truly yours,

Marcelo Contrucci
Principal Engineer
Ship Engineering Department

cc: ABS Chicago - w/inv

Caterpillar Marine Power
3701 State Road 26 E.
Lafayette, IN 47905
Attn: Mr. James L Thien-w/inv

AMERICAS DIVISION

ABS PLAZA, 16855 NORTHCHASE DRIVE, HOUSTON, TX 77060 USA

TEL: 1-281-877-6000

FAX: 1-281-877-6001

EMAIL: ABS-amer@eagle.org

WEBSITE: www.eagle.org

E2 & E3 & C1 Technical File for 3400C Marine Engine

@ 1350 & 1800 & 2100 RPM
(Engine Family 3400CP1350&1800&2100)

| | |
|--------------------------|----------------------|
| Engine Model | 3412C |
| Engine Serial No. | 38S25392 |
| Emissions Cycle | C1 |
| Performance Spec. | 0K-2777 |
| Build Date | June 25, 2009 |



**Do Not Discard
This Document is to be kept on board.**

**This document satisfies the requirements of
IMO Technical Code on Control of Emission of Nitrogen Oxides from Marine Diesel Engines.
Technical File Approval No.
ABS NTC**

Table of Contents

| | |
|---|-----------|
| 3400C Engine Part Number Table* | 3 |
| Installation Requirements | 9 |
| Engine Performance | 9 |
| Engine Emissions | 9 |
| On-board Nox Verification procedure | 10 |
| Engine Parameter Check Method | 10 |
| 1. Check Engine Parameters:..... | 11 |
| 2. Identify Emission-Related Engine Components: | 14 |
| 3. Record Changes to Emissions Related Components:..... | 15 |
| 4. Identify Adjustable Features : | 15 |
| Appendix A: IMO Certification Test Report – E2 | 16 |
| Engine Information* | 16 |
| Engine Family Information* | 17 |
| Test Cell Information* | 18 |
| Ambient and Gaseous Emissions Data* | 19 |
| Engine Test Data* | 20 |
| Appendix B: IMO Certification Test Report – E3 | 21 |
| Engine Information* | 21 |
| Engine Family Information* | 22 |
| Test Cell Information* | 23 |
| Ambient and Gaseous Emissions Data* | 24 |
| Engine Test Data* | 25 |
| Appendix C: IMO Certification Test Report - C1 | 26 |
| Engine Information* | 26 |
| Engine Family*..... | 27 |
| Test Cell Information* | 28 |
| Ambient and Gaseous Emissions Data* | 29 |
| Engine Test Data* | 30 |

See ABS Houston Letter Ref 515959 Dated 14-OCT-2009

3400C Engine Part Number Table*

| Performance Specification | | 0K-2022 | 0K-2026 | 0K-2021 | 0K-2018 | 0K-2019 | 0K-2020 | 0K-6219 |
|---------------------------|-------------|----------|----------|----------|----------|----------|----------|----------------------|
| Engine Ratings | Application | B | A | B | A | A | A | A |
| | rpm | 1800 | 1800 | 1800 | 1800 | 1800 | 1800 | 1800 |
| | BkW | 537 | 485 | 459 | 448 | 403 | 375 | 447.5 |
| | (bhp) | (720) | (650) | (615) | (600) | (540) | (503) | (600) |
| Engine Model | Part Number | 3412C | 3412C | 3412C | 3412C | 3412C | 3412C | 3412C |
| Compression Ratio | | 14.5:1 | 14.5:1 | 14.5:1 | 14.5:1 | 14.5:1 | 14.5:1 | 14.5:1 |
| Static Timing (BTDC) | Deg. | 30.0 | 30.0 | 27.2 | 27.2 | 27.2 | 27.2 | 27.2 |
| Piston | Part Number | 9Y7212 | 9Y7212 | 9Y7212 | 9Y7212 | 9Y7212 | 9Y7212 | 9Y7212 |
| Cylinder Head | Part Number | 105-3797 | 105-3797 | 105-3797 | 105-3797 | 105-3797 | 105-3797 | 105-3797 |
| Camshaft | Part Number | 6N5768 | 6N5768 | 6N5768 | 6N5768 | 6N5768 | 6N5768 | 6N5768 |
| Aftercooler | Part Number | 2W6593 | 2W6593 | 2W6593 | 2W6593 | 2W6593 | 2W6593 | 2W6593 |
| Turbocharger Basic Group | Part Number | 4W1148 | 4W1148 | 6N2020 | 6N2020 | 6N2020 | 6N2020 | 6N2020 |
| Fuel Pump | Part Number | 4W8618 | 4W8618 | 184-6485 | 184-6485 | 184-6485 | 184-6485 | 184-6485 108-3697 |
| Nozzle | Part Number | 4W7018 | 4W7018 | 4W7019 | 4W7019 | 4W7019 | 4W7019 | 4W7019 |

*** Note; Replacement part may change**

The part numbers of the components listed above were valid in June 2002, but may change over time. They may not necessarily be the specific part numbers that this engine was shipped with. See also section “Record Changes to Emission Related Components”.

3400C Engine Part Number Table*

| Performance Specification | | 0K-2023 | 0K-2024 | 0K-2025 | 0K-2027 | 0K-1991 | 0K-1992 |
|---------------------------|-------------|----------|----------|----------|----------|----------|----------|
| Engine Ratings | Application | C | C | D | E | C | B |
| | rpm | 2100 | 2100 | 2100 | 2100 | 2100 | 2100 |
| | BkW | 570 | 615 | 671 | 746 | 403 | 384 |
| | (bhp) | (764) | (825) | (900) | (1001) | (540) | (515) |
| Engine Model | Part Number | 3412C | 3412C | 3412C | 3412C | 3408C | 3408C |
| Compression Ratio | | 14.5 | 14.5 | 14.5 | 14.5 | 14.5 | 14.5 |
| Static Timing (BTDC) | Deg. | 30.0 | 25.0 | 25.0 | 25.0 | 28.0 | 28.0 |
| Piston | Part Number | 9Y-7212 | 174-6102 | 174-6102 | 174-6102 | 9Y-7212 | 9Y-7212 |
| Cylinder Head | Part Number | 105-3797 | 105-3797 | 105-3797 | 105-3797 | 105-3787 | 105-3787 |
| Camshaft | Part Number | 6N-5768 | 6N-5768 | 6N-5768 | 6N-5768 | 1W-5060 | 1W-5060 |
| Aftercooler | Part Number | 2W-6593 | 2W-6593 | 2W-6593 | 2W-6593 | 2W-6587 | 2W-6587 |
| Turbocharger Basic Group | Part Number | 4W-1148 | 4P-8576 | 4P-8576 | 4P-8576 | 1W-5285 | 1W-5285 |
| Fuel Pump | Part Number | 4W-8618 | 102-9728 | 102-9728 | 102-9728 | 4N-4267 | 4N-4267 |
| Nozzle | Part Number | 4W-7018 | 4W-7018 | 4W-7018 | 4W-7018 | 4W-7018 | 4W-7018 |

*** Note; Replacement part may change**

The part numbers of the components listed above were valid in June 2002, but may change over time. They may not necessarily be the specific part numbers that this engine was shipped with. See also section "Record Changes to Emission Related Components".

3400C Engine Part Number Table*

| Performance Specification | | 0K-1990 | 0K-1989 | 0K-1993 | 0K-1695 | 0K-1846 | 0K-1845 |
|---------------------------|-------------|----------|----------|----------|--------------------|--------------------|--------------------|
| Engine Ratings | Application | B | A | A | B | B | A |
| | rpm | 1800 | 1800 | 1800 | 1350 | 1800 | 1800 |
| | BkW | 358 | 339 | 300 | 231 | 224 | 187 |
| | (bhp) | (480) | (455) | (402) | (310) | (300) | (250) |
| Engine Model | Part Number | 3408C | 3408C | 3408C | 3406C | 3406C | 3406C |
| Compression Ratio | | 14.5:1 | 14.5:1 | 14.5:1 | 14.5:1 | 14.5:1 | 14.5:1 |
| Static Timing (BTDC) | Deg. | 28.0 | 28.0 | 28.0 | 21.0 | 24.0 | 24.0 |
| Piston | Part Number | 9Y7212 | 9Y7212 | 9Y7212 | 9Y4004 290-0017 | 9Y4004 290-0017 | 9Y4004 290-0017 |
| Cylinder Head | Part Number | 105-3787 | 105-3787 | 105-3787 | 110-5100 | 110-5100 | 110-5100 |
| Camshaft | Part Number | 1W5060 | 1W5060 | 1W5060 | 100-7409 | 100-7409 | 100-7409 |
| Aftercooler | Part Number | 2W6587 | 2W6587 | 2W6587 | 1W6990 | 1W6990 | 1W6990 |
| Turbocharger Basic Group | Part Number | 1W5285 | 1W5285 | 1W5285 | 7C4763 | 7C6702 | 7C6702 |
| Fuel Pump | Part Number | 7C3758 | 7C3758 | 4W6651 | 178-1725 | 7W6071 | 7W6071 |
| Nozzle | Part Number | 4W7018 | 4W7018 | 4W7018 | 4W7017 | 4W7018 | 4W7018 |

*** Note; Replacement part may change**

The part numbers of the components listed above were valid in June 2002, but may change over time. They may not necessarily be the specific part numbers that this engine was shipped with. See also section "Record Changes to Emission Related Components".

3400C Engine Part Number Table*

| Performance Specification | | 0K-1696 | 0K-1697 | 0K-1698 | 0K-1699 | 0K-1700 | 0K-1837 |
|---------------------------|-------------|----------|---------------------|---------------------|----------|----------|----------|
| Engine Ratings | Application | A | A | B | B | C | D |
| | rpm | 1800 | 1800 | 1800 | 2100 | 2100 | 2100 |
| | BkW | 240 | 272 | 298 | 328 | 358 | 399 |
| | (bhp) | (322) | (365) | (400) | (440) | (480) | (535) |
| Engine Model | Part Number | 3406C | 3406C | 3406C | 3406C | 3406C | 3406C |
| Compression Ratio | | 14.5:1 | 14.5:1 | 14.5:1 | 14.5:1 | 14.5:1 | 14.5:1 |
| Static Timing (BTDC) | Deg. | 14 | 14 | 14 | 14 | 14 | 14 |
| Piston | Part Number | 160-1131 | 9Y-4004 290-0017 | 9Y-4004 290-0017 | 160-1131 | 160-1131 | 160-1131 |
| Cylinder Head | Part Number | 1W-1506 | 1W-1506 | 1W-1506 | 1W-1506 | 1W-1506 | 1W-1506 |
| | | 7W-2200 | 7W-2200 | 7W-2200 | 7W-2200 | 7W-2200 | 7W-2200 |
| | | 110-5100 | 110-5100 | 110-5100 | 110-5100 | 110-5100 | 110-5100 |
| Camshaft | Part Number | 7W-3796 | 7W-3796 | 7W-3796 | 7W-3796 | 7W-3796 | 7W-3796 |
| | | 100-7409 | 100-7409 | 100-7409 | 100-7409 | 100-7409 | 100-7409 |
| Aftercooler | Part Number | 1W-6990 | 1W-6990 | 1W-6990 | 1W-6990 | 1W-6990 | 1W-6990 |
| Turbocharger Basic Group | Part Number | 110-8463 | 110-8463 | 110-8463 | 110-7897 | 110-7897 | 110-7897 |
| Fuel Pump | Part Number | 110-8897 | 110-8897 | 110-8897 | 110-8897 | 110-8897 | 110-8897 |
| | | 110-8896 | 110-8896 | 110-8896 | 110-8896 | 110-8896 | 110-8896 |
| Nozzle | Part Number | 7W-7031 | 7W-7031 | 7W-7031 | 7W-7031 | 7W-7031 | 7W-7031 |

*** Note; Replacement part may change**

The part numbers of the components listed above were valid in June 2002, but may change over time. They may not necessarily be the specific part numbers that this engine was shipped with. See also section "Record Changes to Emission Related Components".

3400C Engine Part Number Table*

| Performance Specification | | 0K-1988 | 0K-7180 | 0K-3020 | 2T-7950 | 2T-8113 | 0K-2777 |
|---------------------------|-------------|----------|----------|----------|----------|----------|----------|
| Engine Ratings | Application | E | B | C | C | C | C |
| | rpm | 2100 | 2100 | 2100 | 2100 | 2100 | 2100 |
| | BkW | 432.5 | 328 | 365.5 | 391.5 | 373 | 567 |
| | (bhp) | (580) | (440) | (490) | (525) | (500) | (760) |
| Engine Model | Part Number | 3406C | 3406C | 3406C | 3408C | 3406C | 3412C |
| Compression Ratio | | 14.5:1 | 14.5:1 | 14.6:1 | 14.7:1 | 14.6:1 | 14.5 |
| Static Timing (BTDC) | Deg. | 15 | 14 | 17.5 | 22.5 | 18.5 | 30.0 |
| Piston | Part Number | 160-1131 | 160-1131 | 125-8869 | 174-6103 | 125-8869 | 9Y-7212 |
| Cylinder Head | Part Number | 1W-1506 | 1W-1506 | 1W-1506 | 105-3787 | 1W-1506 | 105-3797 |
| | | 7W-2200 | 7W-2200 | 7W-2200 | | 7W-2200 | |
| | | 110-5100 | 110-5100 | 110-5100 | | 110-5100 | |
| Camshaft | Part Number | 7W-3796 | 7W-3796 | 6N-4990 | 1W-5060 | 100-7409 | 6N-5768 |
| | | 100-7409 | 100-7409 | | | | |
| Aftercooler | Part Number | 1W-6990 | 1W-6990 | 1W-6990 | 2W-6587 | 1W-4879 | 2W-6593 |
| Turbocharger Basic Group | Part Number | 110-7897 | 110-7897 | 110-8463 | 117-6514 | 130-5469 | 4W-1226 |
| Fuel Pump | Part Number | 111-9363 | 110-8897 | 135-2699 | 130-3239 | 135-2691 | 4W-8617 |
| | | 178-1728 | 152-9080 | | | | |
| Nozzle | Part Number | 7W-7031 | 7W-7031 | 130-5187 | 129-1351 | 130-5187 | 4W-7018 |

*** Note; Replacement part may change**

The part numbers of the components listed above were valid in June 2002, but may change over time. They may not necessarily be the specific part numbers that this engine was shipped with. See also section "Record Changes to Emission Related Components".

3400C Engine Part Number Table*

| Performance Specification | | 2T-7811 | 2T-8983 | 2T-9017 | 2T-9722 | 0K-1554 | 0K5589 |
|---------------------------|-------------|----------|----------|----------|----------|----------|----------|
| Engine Ratings | Application | C | C | C | C | D | B |
| | rpm | 2100 | 2100 | 2100 | 2100 | 2100 | 1800 |
| | BkW | 559 | 365 | 373 | 391.5 | 641 | 632 |
| | (bhp) | (750) | (489) | (500) | (525) | (860) | (848) |
| Engine Model | Part Number | 3412C | 3406C | 3406C | 3408C | 3412C | 3412D |
| Compression Ratio | | 14.7 | 14.6 | 14.6 | 14.7 | 14.5:1 | 15.0:1 |
| Static Timing (BTDC) | Deg. | 26.0 | 17.5 | 18.5 | 22.5 | 30.0 | 22.5 |
| Piston | Part Number | 174-6103 | 125-8869 | 125-8869 | 174-6103 | 9Y-7212 | 236-1848 |
| Cylinder Head | Part Number | 105-3797 | 110-5100 | 110-5100 | 105-3787 | 105-3797 | 143-0047 |
| Camshaft | Part Number | 6N-5768 | 6N-4990 | 100-7409 | 1W-5060 | 6N-5768 | 6N-5768 |
| Aftercooler | Part Number | 2W-6593 | 1W-6990 | 1W-4879 | 2W-6587 | 2W-6593 | 2W-6593 |
| Turbocharger Basic Group | Part Number | 103-4051 | 110-8463 | 130-5469 | 117-6514 | 4W-1226 | 240-4567 |
| Fuel Pump | Part Number | 129-1356 | 135-2699 | 135-2691 | 130-3239 | 4W-8617 | 239-9637 |
| Nozzle | Part Number | 129-1351 | 130-5187 | 130-5187 | 129-1351 | 4W-7018 | 239-9634 |

*** Note; Replacement part may change**

The part numbers of the components listed above were valid in June 2002, but may change over time. They may not necessarily be the specific part numbers that this engine was shipped with. See also section "Record Changes to Emission Related Components".

Installation Requirements

The following installation requirements must be met at rated load and speed to enable the engine to comply with the nitrogen oxides (NO_x) emission limits of regulation 13 of Annex VI of MARPOL 73/78:

| | |
|---|--------------------------------|
| Max. Jacket Water Inlet Temperature | 92 °C (198°F) |
| Max. Aftercooler Water Inlet Temperature For Jacket water aftercooled engines: | 83°C (181°F) |
| Maximum Air Inlet Restriction | 6.5 kPa (26" Water) |
| Maximum Exhaust Backpressure | 6.7 kPa (27" Water) A/B/C Tier |

Engine Performance

The rated speed and rated power of the engine is included on the engine information nameplate. This nameplate is located on top of the rear valve cover in front of the recess or boss.

Engine Emissions

Emissions data measurement is consistent with the procedures described in Resolution 2 of the 1997 MARPOL Conference "Technical Code on Control of Emissions of Nitrogen Oxides from Marine Diesel Engines". This engine's exhaust emissions are in compliance with the International Maritime Organization's Regulation 13 of Annex VI to the MARPOL 73/78 Convention. The NO_x limit for the 1350 rpm rated speed parent engine and the engines in this family is 10.65 g/kw-hr, for E2 and E3 cycle. For C1 cycle engines greater than 2000 RPM, the NO_x limit is 9.8 g/kw-hr.

On-board Nox Verification procedure

Engine Parameter Check Method

Introduction:

The engine parameter check method that follows shall be used by the surveyor to verify that the engine, as installed on board the ship, complies with the nitrogen oxides (NOx) emission limits of Regulation 13 of Annex VI of MARPOL 73/78. This method is to be used for the initial certification survey, periodic and intermediate surveys.

Procedures:

The procedures listed below are detailed on the following pages. They can be used to demonstrate compliance with the NOx emissions limits.

Steps of Engine Parameter Check Method:

1. Check Engine Parameter
2. Identify Emission-Related Engine Components
3. Record Changes to Emissions Related Components
4. Identify Adjustable Features

See ABS Houston Letter Ref 515959 Dated 14-OCT-2009

1. Check Engine Parameters:

The adjustable parameters of this engine are:

- High Idle Engine speed*
- Full Load Fuel Setting*
- Full Torque Fuel Setting*
- Fuel Injection Timing

*These adjustment parameters are sealed from the factory. Inspection to confirm the factory or authorized dealer seal is in tact is sufficient to confirm these parameters are acceptable.

Fuel injection timing is adjusted at the factory and should never need to be changed. However, a technician with training in fuel system and governor adjustments should be the only one to make adjustments should the need arise.

Checking Engine Timing by pin timing method basically moves the engine's number 1 piston to top center and ensures the fuel pump is in the proper orientation by inserting a pin into a slot on the fuel pump shaft.

Tools Needed:

- 9S9082 Engine Turning Tool
- 6V4186 Timing Pin (3406C)
- 6V6019 Timing Pin (3408C & 3412C)

Procedure:

NOTE: On some engines there are two threaded holes in the flywheel. These holes are in alignment with the holes with plugs in the left and right front of the flywheel housing. These two holes in the flywheel are at a different distance from the center of the flywheel so the timing bolt cannot be put in the wrong hole.

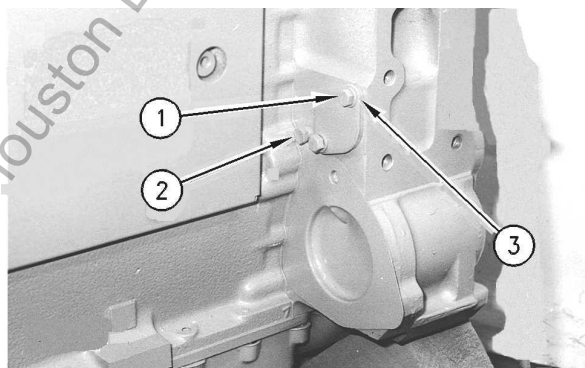

LOCATING TOP CENTER (LEFT SIDE OF ENGINE)

1. Timing bolt. 2. Timing bolt location. 3. Storage location.

1. Timing bolt (1) is kept in storage at location (3) and can be installed in either the left side of the engine at location (2) or in the right side of the engine at location (4). Remove bolts and cover form the flywheel housing. Remove the plug from the timing hole in the flywheel housing.

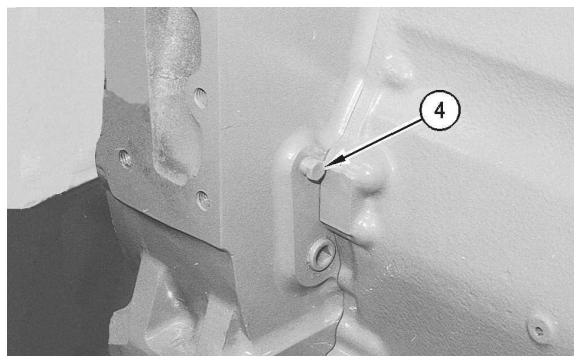

LOCATING TOP CENTER (RIGHT SIDE OF ENGINE)
4. Timing bolt location.

2. Put the timing pin bolt (1) [long bolt that holds cover on the flywheel housing] through the timing hole in the flywheel housing. Use the 9S9082 Engine Turning Tool and a ½ “ drive ratchet wrench to turn the engine flywheel in the direction of normal engine rotation until the timing bolt engages with the threaded hole in the flywheel.

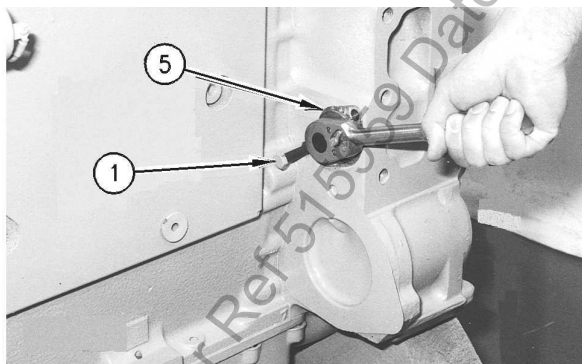

USING 9S9082 TURNING TOOL
1. Timing bolt. 5. 9S9082 Engine Turning tool.

NOTE: If the flywheel is turned beyond the point that the timing bolt engages in the threaded hole, the flywheel must be turned opposite normal engine rotation approximately 30 degrees. Then turn the flywheel in the direction of normal rotation until timing bolt engages the threaded hole. The reason for this procedure is to make sure the play is removed from the gears when No. 1 piston is put on top center.

3. Remove the forward valve cover on the left hand side of the engine as viewed from the flywheel.
4. The intake and exhaust valves for the No. 1 cylinder (furthest away from the flywheel) are closed if No. 1 piston is on the compression stroke and the rocker arms can be moved by hand. If the rocker arms cannot be moved and the valves are slightly open, the flywheel must be turned again. Remove the timing bolt and turn the flywheel in the direction of normal engine rotation 360 degrees until the timing bolt can be installed. The number one piston is now at top center compression position.

5. Remove the timing bolt from the flywheel and use the 9S9082 Engine Turning Tool to rotate the crankshaft clockwise 45° as seen from the flywheel end of the engine.
6. Remove the plug at the side of the fuel injection pump (3406C) or the front end of the fuel injection pump housing (3408C and 3412C).

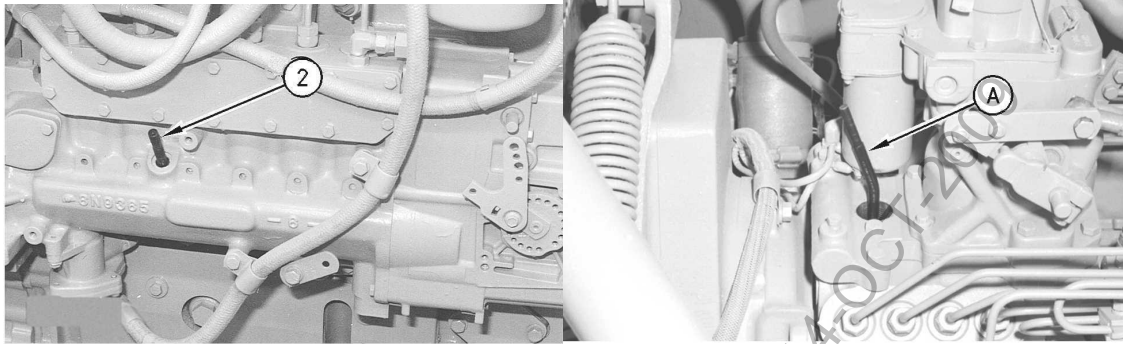

TIMING PIN INSTALLED (3406C)
6V4186 Timing Pin.A.

TIMING PIN INSTALLED (3408C & 3412C)
6V6019 Timing Pin.

7. Install 6V4186 Timing Pin (2) for 3406C or 6V6019 Timing Pin (A) [end with taper] for 3408C and 3412C through the hole in the injection pump. Slowly rotate the crankshaft counterclockwise (as seen from the flywheel end of the engine) until timing pin goes into the slot in the fuel pump camshaft.
8. If timing is correct, the timing pin will go into the notch in the camshaft and the timing bolt will turn into the threaded hole in the flywheel. If the timing is NOT correct, contact a properly qualified Caterpillar service technician to have the fuel injection pump timing corrected.

NOTE: If timing is correct, BE SURE TO REMOVE TIMING PIN AND TIMING BOLT.

2. Identify Emission-Related Engine Components:

The table below lists the components that influence the engine's NOx emissions for this engine model. The list under section Engine Part Numbers Table of this document shows the part numbers of those components as shipped from Caterpillar Inc. factories.

These part numbers can be identified through the engine rating, which is also listed in this same table of this Technical File.

The engine rating can be found on the Information Plate or film on this engine.

Note to surveyor:

See also section "Record Changes to Emission Related Components"

Note to Caterpillar dealers:

Part numbers for the components influencing the NOx can also be found in the Technical Marketing Information (TMI) system by viewing the engine test specification number.

Compare the observed part number with the part number from the table on page 3 to insure that the part numbers are correct for these emissions related components.

Emission Related Component List:

| Component Description: | Location on engine of component part No.: |
|-------------------------------|--|
| Static Timing | On the name plate of the engine. |
| Piston (See note 1) | On the top of the piston crown assembly. |
| Cylinder Head | Cast into the side face of the cylinder head. |
| Camshaft (See note 1) | Stamped or etched on the end of the camshaft. |
| Aftercooler (See note 1) | Stamped or etched on the aftercooler core assembly on the mounting flange. |
| Turbocharger | On nameplate of turbocharger. |
| Fuel Pump | Stamped on top of pump housing. |
| Nozzle (See note 1) | Stamped or etched on top of side of nozzle. |

Note 1: Part number not accessible without significant engine disassembly. Therefore it is not necessary to be checked by the surveyor.

Appendix A: IMO Certification Test Report – E2

Engine Information*

| | |
|--|--|
| Emissions Test Report No.: NPC 2004.010 | Sheet 1/5 |
| Engine | |
| Manufacturer | Caterpillar Inc., Peoria, Illinois, USA |
| Engine Type | 3406C |
| Family or Group identification | 3400CP1350&1800&2100 |
| Serial number | 4TB08324 |
| Rated speed | 1350 rpm |
| Rated power | 231 kW |
| Intermediate speed | N/A rpm |
| Maximum torque at intermediate speed | N/A Nm |
| Static injection timing | 21.0 deg BTDC |
| Electronic injection timing | no |
| Variable injection timing | yes |
| Variable turbocharger geometry | no |
| Bore | 137 mm |
| Stroke | 165 mm |
| Nominal compression ratio | 14.5:1 |
| Mean effective pressure at rated power | 1403 kPa |
| Maximum cylinder pressure at rated power | 12,000 kPa |
| Cylinder number and configuration | Number: 6 cyl. , I 6 |
| Auxiliaries | 1 pump |
| Specified ambient conditions: | |
| Maximum sea water temperature | 32 °C |
| Maximum charge air temperature | N/A °C |
| Cooling system spec. intermediate cooler | Yes |
| Cooling system spec. charge air stages | 1 stage |
| Low/high temperature cooling system set points | N/A °C |
| Maximum inlet depression | -6.5 kPa |
| Maximum exhaust back pressure | 6.7 kPa |
| Fuel oil specification | IMO DMX Fuel |
| Fuel oil temperature | 30 °C |
| Lubricating Oil specification | CH4 10W30 CAT PT#5P2586 |
| Application/Intended for: | |
| Customer | |
| Final application/installation, Ship | Ship |
| Final application/installation, Engine | Main: Propulsion acc. to E2 (CPP, Diesel-Electric) |
| Emissions test result: | |
| Cycle | E2 |
| NOx | 9.2 g/kW-hr** |
| Test identification | 3406C GL Certification Test |
| Date/time | 18DEC2003/14:52 |
| Test site/bench | Zeppelin Baumaschinen GmbH |
| Test number | NPC 2004.010 |
| Surveyor | GL, Mr. Neddenien |
| Date and Place of report | 2FEB2004/Hamburg |
| Signature | |

*If applicable

Engine Family Information*

| | |
|---|---|
| Emission Test Report No.: NPC 2004.010 | Sheet 2/5 |
| Engine Family Information (Common specifications) | |
| Combustion cycle | 4 stroke cycle |
| Cooling medium | Water |
| Cylinder configuration | I 6 |
| Method of aspiration | Pressure charged |
| Fuel type to be used on board | Distillate |
| Combustion chamber | Open chamber |
| Valve port configuration | Cylinder head |
| Valve port size and number | 4 valves per cylinder Intake dia.: 44.53 mm Exhaust dia.: 41.35 mm |
| Fuel system type | Pump and Lines |
| Miscellaneous features: | |
| Exhaust gas recirculation | No |
| Water injection/emulsion | No |
| Air injection | No |
| Charge cooling system | Yes |
| Exhaust after-treatment | No |
| Exhaust after-treatment type | N/A |
| Dual fuel | No |
| Engine Family Information (Selection of parent engine for test bed test) | |
| Family Identification | 3400CP1350&1800&2100 |
| Method of pressure charging | Turbocharged |
| Charge air cooling system | Jacket water aftercooled |
| Criteria of the Selection (specify) | Maximum E2 weighted NOx |
| Number of cylinder (parent) | 6 |
| Max. rated power per cylinder (parent) | 39 kW |
| Rated speed | 1350 rpm |
| Injection timing (range) | 22.2 to 26.9 °BTDC |
| Max. fuel parent engine | 862 g/min |
| Selected parent engine | 3406C, Performance Specification 0K-1695 |
| Application | Propulsion |

* If applicable

Test Cell Information*

| | | | | |
|--|-------------------------|--|--|------------------|
| Emissions Test Report No.: NPC 2004.010 | | | | Sheet 3/5 |
| Exhaust Pipe | | | | |
| Diameter | 300 mm | | | |
| Length | > 15 m | | | |
| Insulation | no | | | |
| Probe Location | 0.8 after turbo-charger | | | |
| Remark | | | | |

| Measurement equipment | | | | | |
|------------------------------|--------------------|------------------|----------------|----------------|------------|
| | Manufacturer | Model | Measurement | Calibration | |
| | | | Ranges | Span gas conc. | Deviation |
| Analyser | | | | | |
| NOx Analyser | ECO Physics | CLD 700 EL ht AK | 0-2000 ppm | 1759 ppm | < 2% |
| CO Analyzer | Siemens | Ultramat 5E-2R | 250/1000 ppm | 244/889 ppm | < 2% |
| CO2 Analyzer | Siemens | Ultramat 5E | 0 – 10% | 9.25 % | < 2% |
| O2 Analyzer | Siemens | Oxymat 5E | 0 – 25% | 23.4 % | < 2% |
| HC Analyzer | Hartmann&Braun | Fidas 3E | 100/500 ppm | 89/478 ppm | < 2% |
| Speed | Zoellner | PS1-4811-AN | 0-3000 rpm | 12 Nov. 2003 | -- |
| Torque | Zoellner | PS1-4811-AN | 0-1600 Nm | 12 Nov. 2003 | < 0.2 % |
| Power, if applicable | Calculated | | kW | | |
| Fuel flow | Yokogawa | RCCS14/SG | 0-1000 l/h | 26 Nov.2003 | < 0.23 % |
| Air flow | | | | | |
| Exhaust flow | | | | | |
| Temperatures | | | | | |
| Coolant | Dewetron | PAD-RTD3 | 0-200 °C | 10 Sep. 2003 | < 0.1 % |
| Lubricant | Dewetron | PAD-RTD3 | 0-200 °C | 10 Sep. 2003 | < 0.1 % |
| Exhaust gas | Dewetron | PAD-TH8-P | -270-1372 °C | 10 Sep. 2003 | < 0.05 % |
| Inlet air | Rotronic Hydroclip | Type S | -40 to + 85 °C | | +/- 0.3 °C |
| Intercooled air | Dewetron | PAD-RTD3 | 0-200 °C | 28 Nov. 2003 | < 0.1 % |
| Fuel | Yokogawa | RCCS14/SG | -20 to +80 °C | 26 Nov.2003 | < 0.23 % |
| Pressures | | | | | |
| Exhaust gas | Dewetron | PAD-V8-P | 0-100 mbar | 28 Nov. 2003 | < 0.5 % |
| Inlet manifold | Dewetron | PAD-V8-P | 0-10 mbar | 28 Nov. 2003 | < 0.5 % |
| Atmospheric | Greisinger | Type GMDP | 0 - 1100 hPa | | +/- 1 hPa |
| Vapor pressure | | | | | |
| Intake air | | | | | |
| Dew Point | | | | | |
| Intake air | Rotronic Hydroclip | Type S | 0 to 100 % rH | | +/- 1.5 % |

Fuel Characteristics

| Fuel type | DIN EN 590 | | | | |
|-------------------------|------------|-------------|--------------------------------|-------|--------|
| Fuel properties: | | | Fuel elemental analysis | | |
| Density | ISO 3675 | 831.4 kg/l | Carbon | 86.45 | % mass |
| Viscosity | ISO 3104 | 2.379 mm2/s | Hydrogen | 13.54 | % mass |
| | | | Nitrogen | < 0.1 | % mass |
| | | | Oxygen | < 0.1 | % mass |
| | | | Sulphur | < 1.0 | % mass |
| | | | LHV/Hu | 45.80 | MJ/kg |

* If Applicable

Ambient and Gaseous Emissions Data*

| | | | | | |
|--|---|-------|-------|-------|------------------|
| Emissions Test Report No.: NPC 2004.010 | | | | | Sheet 4/5 |
| Mode | | 1 | 2 | 3 | 4 |
| Power/Torque | % | 100 | 75 | 50 | 25 |
| Speed | % | 100 | 100 | 100 | 100 |
| Time at beginning of mode | | 14:52 | 15:12 | 15:33 | 15:56 |

| | | | | | |
|-------------------------|------|-------|-------|-------|-------|
| Ambient Data | | | | | |
| Atmospheric pressure | mbar | 1020 | 1020 | 1020 | 1019 |
| Intake air temperature | °C | 22.2 | 21.4 | 23.7 | 21.5 |
| Intake air humidity | % | 24.6 | 25.5 | 22.0 | 25.1 |
| Atmospheric factor (fa) | | 0.970 | 0.966 | 0.977 | 0.967 |

| | | | | | |
|---------------------------------|---------|-------|-------|-------|-------|
| Gaseous Emissions Data: | | | | | |
| NOx concentration wet | ppm | 1006 | 1083 | 1083 | 1044 |
| CO concentration dry | ppm | 557 | 396 | 348 | 226 |
| CO2 concentration dry | % | 9.41 | 8.93 | 8.50 | 6.76 |
| O2 concentration dry | % | 7.68 | 8.28 | 8.85 | 11.30 |
| HC concentration wet | ppm | 27 | 32 | 32 | 51 |
| NOx humidity correction factor | | 0.917 | 0.916 | 0.922 | 0.914 |
| Fuel specification factor (FFH) | | 1.867 | 1.871 | 1.874 | 1.888 |
| Dry/wet correction factor | | 0.912 | 0.916 | 0.919 | 0.934 |
| NOx mass flow | kg/hr | 1.78 | 1.61 | 1.22 | 0.75 |
| CO mass flow | kg/hr | 0.60 | 0.36 | 0.24 | 0.10 |
| CO2 mass flow | kg/hr | 159 | 127 | 91 | 47 |
| O2 mass flow | kg/hr | 94 | 86 | 69 | 58 |
| HC mass flow | kg/hr | 0.02 | 0.02 | 0.01 | 0.01 |
| SO2 mass flow | kg/hr | N/A | N/A | N/A | N/A |
| NOx specific | g/kW hr | 7.75 | 9.32 | 10.62 | 13.09 |

* If Applicable

Engine Test Data*

| Emissions Test Report No.: NPC 2004.010 | | | | | Sheet 5/5 |
|---|---|-------|-------|-------|-----------|
| Mode | | 1 | 2 | 3 | 4 |
| Power/Torque | % | 100 | 75 | 50 | 25 |
| Speed | % | 100 | 100 | 100 | 100 |
| Time at beginning of mode | | 14:52 | 15:12 | 15:33 | 15:56 |

| Engine Data | | | | | |
|------------------------------------|--------|-------|-------|--------|--------|
| Speed | rpm | 1347 | 1352 | 1350 | 1352 |
| Auxiliary power | kW | 0 | 0 | 0 | 0 |
| Dynamometer setting | Nm | 1631 | 1222 | 813 | 404 |
| Power | kW | 230 | 173 | 115 | 57 |
| Mean effective pressure | bar | 14.03 | 10.52 | 7.02 | 3.51 |
| Fuel rack | mm | 3.050 | 0.919 | -1.323 | -3.559 |
| Uncorrected spec. fuel consumption | g/kWhr | 221 | 235 | 254 | 264 |
| Fuel flow | kg/hr | 50.8 | 40.7 | 29.2 | 15.1 |
| Air flow | kg/hr | 1088 | 923 | 751 | 620 |
| Exhaust flow (gexhw) | kg/hr | 1218 | 1025 | 770 | 494 |
| Exhaust temperature | °C | 430.7 | 385.6 | 325.4 | 245.6 |
| Exhaust back pressure | mbar | 0.96 | 0.54 | 0.18 | -0.22 |
| Cylinder Coolant temperature out | °C | 89.9 | 87.4 | 85.6 | 83.7 |
| Cylinder Coolant temperature in | °C | 32.9 | 28.1 | 33.0 | 35.3 |
| Cylinder Coolant pressure | bar | 0.55 | 0.52 | 0.48 | 0.45 |
| Aftercooler Coolant temperature in | °C | 59.3 | 58.8 | 58.9 | 58.0 |
| Temperature intercooled air | °C | 87.7 | 83.2 | 80.5 | 78.7 |
| Lubricant temperature | °C | 96.5 | 93.9 | 92.0 | 89.4 |
| Lubricant pressure | bar | 369.7 | 376.5 | 381.9 | 388.7 |
| Inlet depression | mbar | -3.28 | -2.38 | -1.58 | -1.05 |

Appendix B: IMO Certification Test Report – E3

Engine Information*

| Emissions Test Report No.: NPC 2004.010 | Sheet 1/5 |
|--|---|
| Engine | |
| Manufacturer | Caterpillar Inc., Peoria, Illinois, USA |
| Engine Type | 3406C |
| Family or Group identification | 3400CP1350&1800&2100 |
| Serial number | 4TB08324 |
| Rated speed | 1350 rpm |
| Rated power | 231 kW |
| Intermediate speed | N/A rpm |
| Maximum torque at intermediate speed | N/A Nm |
| Static injection timing | 21.0 deg BTDC |
| Electronic injection timing | no |
| Variable injection timing | yes |
| Variable turbocharger geometry | no |
| Bore | 137 mm |
| Stroke | 165 mm |
| Nominal compression ratio | 14.5:1 |
| Mean effective pressure at rated power | 1403 kPa |
| Maximum cylinder pressure at rated power | 12,000 kPa |
| Cylinder number and configuration | Number: 6 cyl. , I 6 |
| Auxiliaries | 1 pump |
| Specified ambient conditions: | |
| Maximum sea water temperature | 32 °C |
| Maximum charge air temperature | N/A °C |
| Cooling system spec. intermediate cooler | Yes |
| Cooling system spec. charge air stages | 1 stage |
| Low/high temperature cooling system set points | N/A °C |
| Maximum inlet depression | -6.5 kPa |
| Maximum exhaust back pressure | 6.7 kPa |
| Fuel oil specification | IMO DMX Fuel |
| Fuel oil temperature | 30 °C |
| Lubricating Oil specification | CH4 10W30 CAT PT#5P2586 |
| Application/Intended for: | |
| Customer | |
| Final application/installation, Ship | Ship |
| Final application/installation, Engine | Main: Propulsion |
| Emissions test result: | |
| Cycle | E3 |
| NOx | 9.1 g/kW-hr** |
| Test identification | 3406C GL Certification Test |
| Date/time | 18DEC2003/14:52 |
| Test site/bench | Zeppelin Baumaschinen GmbH |
| Test number | NPC 2004.010 |
| Surveyor | GL, Mr. Neddenien |
| Date and Place of report | 2FEB2004/Hamburg |
| Signature | |

* If applicable

Engine Family Information*

| | |
|---|---|
| Emission Test Report No.: NPC 2004.010 | Sheet 2/5 |
| Engine Family Information (Common specifications) | |
| Combustion cycle | 4 stroke cycle |
| Cooling medium | Water |
| Cylinder configuration | V8 |
| Method of aspiration | Pressure charged |
| Fuel type to be used on board | Distillate |
| Combustion chamber | Open chamber |
| Valve port configuration | Cylinder head |
| Valve port size and number | 4 valves per cylinder Intake dia.: 44.53 mm Exhaust dia.: 41.35 mm |
| Fuel system type | Pump and Lines |
| Miscellaneous features: | |
| Exhaust gas recirculation | No |
| Water injection/emulsion | No |
| Air injection | No |
| Charge cooling system | Yes |
| Exhaust after-treatment | No |
| Exhaust after-treatment type | N/A |
| Dual fuel | No |
| Engine Family Information (Selection of parent engine for test bed test) | |
| Family Identification | 3400CP1350&1800&2100 |
| Method of pressure charging | Turbocharged |
| Charge air cooling system | Jacket water aftercooled |
| Criteria of the Selection (specify) | Maximum E3 weighted NOx |
| Number of cylinder (parent) | 6 |
| Max. rated power per cylinder (parent) | 39 kW |
| Rated speed | 1350 rpm |
| Injection timing (range) | 22.2 to 26.9 °BTDC |
| Max. fuel parent engine | 862 g/min |
| Selected parent engine | 3406C, Performance Specification 0K-1695 |
| Application | Propulsion |

* If applicable

Test Cell Information*

| | | | | |
|--|-------------------------|--|--|------------------|
| Emissions Test Report No.: NPC 2004.010 | | | | Sheet 3/5 |
| Exhaust Pipe | | | | |
| Diameter | 300 mm | | | |
| Length | > 15 m | | | |
| Insulation | no | | | |
| Probe Location | 0.8 after turbo-charger | | | |
| Remark | | | | |

| Measurement equipment | | | | | |
|------------------------------|--------------------|------------------|----------------|----------------|------------|
| | Manufacturer | Model | Measurement | Calibration | |
| | | | Ranges | Span gas conc. | Deviation |
| Analyser | | | | | |
| NOx Analyser | ECO Physics | CLD 700 EL ht AK | 0-2000 ppm | 1759 ppm | < 2% |
| CO Analyser | Siemens | Ultramat 5E-2R | 250/1000 ppm | 244/889 ppm | < 2% |
| CO2 Analyser | Siemens | Ultramat 5E | 0 – 10% | 9.25 % | < 2% |
| O2 Analyser | Siemens | Oxymat 5E | 0 – 25% | 23.4 % | < 2% |
| HC Analyser | Hartmann&Braun | Fidas 3E | 100/500 ppm | 89/478 ppm | < 2% |
| Speed | Zoellner | PS1-4811-AN | 0-3000 rpm | 12 Nov. 2003 | -- |
| Torque | Zoellner | PS1-4811-AN | 0-1600 Nm | 12 Nov. 2003 | < 0.2 % |
| Power, if applicable | Calculated | | kW | | |
| Fuel flow | Yokogawa | RCCS14/SG | 0-1000 l/h | 26 Nov.2003 | < 0.23 % |
| Air flow | | | | | |
| Exhaust flow | | | | | |
| Temperatures | | | | | |
| Coolant | Dewetron | PAD-RTD3 | 0-200 °C | 10 Sep. 2003 | < 0.1 % |
| Lubricant | Dewetron | PAD-RTD3 | 0-200 °C | 10 Sep. 2003 | < 0.1 % |
| Exhaust gas | Dewetron | PAD-TH8-P | -270-1372 °C | 10 Sep. 2003 | < 0.05 % |
| Inlet air | Rotronic Hydroclip | Type S | -40 to + 85 °C | | +/- 0.3 °C |
| Intercooled air | Dewetron | PAD-RTD3 | 0-200 °C | 28 Nov. 2003 | < 0.1 % |
| Fuel | Yokogawa | RCCS14/SG | -20 to +80 °C | 26 Nov.2003 | < 0.23 % |
| Pressures | | | | | |
| Exhaust gas | Dewetron | PAD-V8-P | 0-100 mbar | 28 Nov. 2003 | < 0.5 % |
| Inlet manifold | Dewetron | PAD-V8-P | 0-10 mbar | 28 Nov. 2003 | < 0.5 % |
| Atmospheric | Greisinger | Type GMDP | 0 - 1100 hPa | | +/- 1 hPa |
| Vapor pressure | | | | | |
| Intake air | | | | | |
| Dew Point | | | | | |
| Intake air | Rotronic Hydroclip | Type S | 0 to 100 % rH | | +/- 1.5 % |

Fuel Characteristics

| Fuel type | | | | | |
|------------------------------------|----------|-------------|--------------------------------|-------|--------|
| Fuel properties: DIN EN 590 | | | | | |
| | | | Fuel elemental analysis | | |
| Density | | | | | |
| Viscosity | ISO 3675 | 831.4 kg/l | Carbon | 86.45 | % mass |
| | ISO 3104 | 2.379 mm2/s | Hydrogen | 13.54 | % mass |
| | | | Nitrogen | < 0.1 | % mass |
| | | | Oxygen | < 0.1 | % mass |
| | | | Sulphur | < 1.0 | % mass |

* If Applicable

Ambient and Gaseous Emissions Data*

| | | | | | | |
|--|---|--|-------|-------|------------------|-------|
| Emissions Test Report No.: NPC 2004.010 | | | | | Sheet 4/5 | |
| Mode | | | 1 | 2 | 3 | 4 |
| Power/Torque | % | | 100 | 75 | 50 | 25 |
| Speed | % | | 100 | 91 | 80 | 63 |
| Time at beginning of mode | | | 14:52 | 16:26 | 16:46 | 17:06 |

| | | | | | | |
|-------------------------|------|--|-------|-------|-------|-------|
| Ambient Data | | | | | | |
| Atmospheric pressure | mbar | | 1020 | 1020 | 1020 | 1020 |
| Intake air temperature | °C | | 22.2 | 23.8 | 21.2 | 20.4 |
| Intake air humidity | % | | 24.6 | 21.8 | 25.6 | 26.7 |
| Atmospheric factor (fa) | | | 0.970 | 0.978 | 0.965 | 0.961 |

| | | | | | | |
|---------------------------------|---------|--|-------|-------|-------|-------|
| Gaseous Emissions Data: | | | | | | |
| NOx concentration wet | ppm | | 1006 | 1049 | 1042 | 659 |
| CO concentration dry | ppm | | 557 | 256 | 152 | 206 |
| CO2 concentration dry | % | | 9.41 | 8.34 | 6.95 | 5.22 |
| O2 concentration dry | % | | 7.68 | 9.20 | 11.12 | 13.49 |
| HC concentration wet | ppm | | 27 | 32 | 32 | 49 |
| NOx humidity correction factor | | | 0.917 | 0.924 | 0.915 | 0.911 |
| Fuel specification factor (FFH) | | | 1.867 | 1.876 | 1.887 | 1.901 |
| Dry/wet correction factor | | | 0.912 | 0.921 | 0.932 | 0.947 |
| NOx mass flow | kg/hr | | 1.78 | 1.58 | 1.34 | 0.60 |
| CO mass flow | kg/hr | | 0.60 | 0.23 | 0.12 | 0.12 |
| CO2 mass flow | kg/hr | | 159 | 120 | 87 | 47 |
| O2 mass flow | kg/hr | | 94 | 96 | 101 | 89 |
| HC mass flow | kg/hr | | 0.02 | 0.02 | 0.01 | 0.01 |
| SO2 mass flow | kg/hr | | N/A | N/A | N/A | N/A |
| NOx specific | g/kW hr | | 7.75 | 9.13 | 11.58 | 10.44 |

* If Applicable

Engine Test Data*

| Emissions Test Report No.: NPC 2004.010 | | | | | Sheet 5/5 |
|---|---|-------|-------|-------|-----------|
| Mode | | 1 | 2 | 3 | 4 |
| Power | % | 100 | 75 | 50 | 25 |
| Speed | % | 100 | 91 | 80 | 63 |
| Time at beginning of mode | | 14:52 | 16:26 | 16:46 | 17:06 |

| Engine Data | | | | | |
|------------------------------------|--------|-------|-------|--------|--------|
| Speed | rpm | 1347 | 1230 | 1080 | 853 |
| Auxiliary power | kW | 0 | 0 | 0 | 0 |
| Dynamometer setting | Nm | 1631 | 1341 | 1222 | 645 |
| Power | kW | 230 | 173 | 116 | 58 |
| Mean effective pressure | bar | 14.03 | 11.62 | 8.80 | 5.59 |
| Fuel rack | mm | 3.050 | 1.319 | -0.460 | -2.480 |
| Uncorrected spec. fuel consumption | g/kWhr | 221 | 221 | 240 | 263 |
| Fuel flow | kg/hr | 50.8 | 38.2 | 27.7 | 15.1 |
| Air flow | kg/hr | 1088 | 856 | 621 | 405 |
| Exhaust flow (gexhw) | kg/hr | 1218 | 1026 | 884 | 630 |
| Exhaust temperature | °C | 430.7 | 403.7 | 364.6 | 278.5 |
| Exhaust back pressure | mbar | 0.96 | -0.28 | 0.00 | 0.34 |
| Cylinder Coolant temperature out | °C | 89.9 | 87.7 | 86.3 | 84.6 |
| Cylinder Coolant temperature in | °C | 32.9 | 32.7 | 30.3 | 32.2 |
| Cylinder Coolant pressure | bar | 0.55 | 0.49 | 0.40 | 0.28 |
| Aftercooler Coolant temperature in | °C | 59.3 | 58.5 | 58.5 | 58.0 |
| Temperature intercooled air | °C | 87.7 | 82.2 | 79.9 | 78.5 |
| Lubricant temperature | °C | 96.5 | 93.4 | 90.9 | 87.8 |
| Lubricant pressure | bar | 369.7 | 370.1 | 365.2 | 322.0 |
| Inlet depression | mbar | -3.28 | -1.93 | -1.07 | -0.40 |

Appendix C: IMO Certification Test Report – C1

**Note: This test conducted in accordance to US EPA procedure 40CFR89 and accepted by ABS
Engine Information***

| Emissions Test Report No.: NPC 2004.010 | Sheet 1/5 |
|--|---|
| Engine | |
| Manufacturer | Caterpillar Inc., Peoria, Illinois, USA |
| Engine Type | 3406C |
| Family or Group identification | 3400CP1350&1800&2100 |
| Serial number | 1A11799 |
| Rated speed | 2100 rpm |
| Rated power | 373 kW |
| Intermediate speed | N/A rpm |
| Maximum torque at intermediate speed | N/A Nm |
| Static injection timing | 18.5 deg BTDC |
| Electronic injection timing | no |
| Variable injection timing | yes |
| Variable turbocharger geometry | no |
| Bore | 137 mm |
| Stroke | 165 mm |
| Nominal compression ratio | 14.6:1 |
| Mean effective pressure at rated power | 1460 kPa |
| Maximum cylinder pressure at rated power | 12026 kPa |
| Cylinder number and configuration | Number: 6 cyl. , I 6 |
| Auxiliaries | 1 pump |
| Specified ambient conditions: | |
| Maximum sea water temperature | 32 °C |
| Maximum charge air temperature | N/A °C |
| Cooling system spec. intermediate cooler | Yes |
| Cooling system spec. charge air stages | 1 stage |
| Low/high temperature cooling system set points | N/A °C |
| Maximum inlet depression | -6.5 kPa |
| Maximum exhaust back pressure | 6.7 kPa |
| Fuel oil specification | |
| Fuel oil temperature | 30 °C |
| Lubricating Oil specification | CH4 10W30 CAT PT#5P2586 |
| Application/Intended for: | |
| Customer | |
| Final application/installation, Ship | Ship |
| Final application/installation, Engine | Variable speed auxiliary |
| Emissions test result: | |
| Cycle | C1 |
| NOx | 8.5 g/kW-hr** |
| Test identification | |
| Date/time | |
| Test site/bench | |
| Test number | |
| Surveyor | |
| Date and Place of report | |
| Signature | |

* If applicable

Engine Family Information*

| | |
|---|---|
| Emission Test Report No.: NPC 2004.010 | Sheet 2/5 |
| Engine Family Information (Common specifications) | |
| Combustion cycle | 4 stroke cycle |
| Cooling medium | Water |
| Cylinder configuration | V8 |
| Method of aspiration | Pressure charged |
| Fuel type to be used on board | Distillate |
| Combustion chamber | Open chamber |
| Valve port configuration | Cylinder head |
| Valve port size and number | 4 valves per cylinder Intake dia.: 44.53 mm Exhaust dia.: 41.35 mm |
| Fuel system type | Pump and Lines |
| Miscellaneous features: | |
| Exhaust gas recirculation | No |
| Water injection/emulsion | No |
| Air injection | No |
| Charge cooling system | Yes |
| Exhaust after-treatment | No |
| Exhaust after-treatment type | N/A |
| Dual fuel | No |
| Engine Family Information (Selection of parent engine for test bed test) | |
| Family Identification | 3400CP1350&1800&2100 |
| Method of pressure charging | Turbocharged |
| Charge air cooling system | Jacket water aftercooled |
| Criteria of the Selection (specify) | Maximum C1 weighted NOx |
| Number of cylinder (parent) | 6 |
| Max. rated power per cylinder (parent) | 62 kW |
| Rated speed | 2100 rpm |
| Injection timing (range) | 18.5 °BTDC |
| Max. fuel parent engine | 1377 g/min |
| Selected parent engine | 3406C, Performance Specification 2T-9017 |
| Application | Variable Speed Auxiliary |

* If applicable

Test Cell Information*

| | | | | |
|--|-------------------------|--|--|------------------|
| Emissions Test Report No.: NPC 2004.010 | | | | Sheet 3/5 |
| Exhaust Pipe | | | | |
| Diameter | 300 mm | | | |
| Length | > 15 m | | | |
| Insulation | no | | | |
| Probe Location | 0.8 after turbo-charger | | | |
| Remark | | | | |

| Measurement equipment | | | | | |
|------------------------------|--------------------|------------------|----------------|----------------|------------|
| | Manufacturer | Model | Measurement | Calibration | |
| | | | Ranges | Span gas conc. | Deviation |
| Analyser | | | | | |
| NOx Analyser | ECO Physics | CLD 700 EL ht AK | 0-2000 ppm | 1759 ppm | < 2% |
| CO Analyzer | Siemens | Ultramat 5E-2R | 250/1000 ppm | 244/889 ppm | < 2% |
| CO2 Analyzer | Siemens | Ultramat 5E | 0 – 10% | 9.25 % | < 2% |
| O2 Analyzer | Siemens | Oxymat 5E | 0 – 25% | 23.4 % | < 2% |
| HC Analyzer | Hartmann&Braun | Fidas 3E | 100/500 ppm | 89/478 ppm | < 2% |
| Speed | Zoellner | PS1-4811-AN | 0-3000 rpm | 12 Nov. 2003 | -- |
| Torque | Zoellner | PS1-4811-AN | 0-1600 Nm | 12 Nov. 2003 | < 0.2 % |
| Power, if applicable | Calculated | | kW | | |
| Fuel flow | Yokogawa | RCCS14/SG | 0-1000 l/h | 26 Nov.2003 | < 0.23 % |
| Air flow | | | | | |
| Exhaust flow | | | | | |
| Temperatures | | | | | |
| Coolant | Dewetron | PAD-RTD3 | 0-200 °C | 10 Sep. 2003 | < 0.1 % |
| Lubricant | Dewetron | PAD-RTD3 | 0-200 °C | 10 Sep. 2003 | < 0.1 % |
| Exhaust gas | Dewetron | PAD-TH8-P | -270-1372 °C | 10 Sep. 2003 | < 0.05 % |
| Inlet air | Rotronic Hydroclip | Type S | -40 to + 85 °C | | +/- 0.3 °C |
| Intercooled air | Dewetron | PAD-RTD3 | 0-200 °C | 28 Nov. 2003 | < 0.1 % |
| Fuel | Yokogawa | RCCS14/SG | -20 to +80 °C | 26 Nov.2003 | < 0.23 % |
| Pressures | | | | | |
| Exhaust gas | Dewetron | PAD-V8-P | 0-100 mbar | 28 Nov. 2003 | < 0.5 % |
| Inlet manifold | Dewetron | PAD-V8-P | 0-10 mbar | 28 Nov. 2003 | < 0.5 % |
| Atmospheric | Greisinger | Type GMDP | 0 - 1100 hPa | | +/- 1 hPa |
| Vapor pressure | | | | | |
| Intake air | | | | | |
| Dew Point | | | | | |
| Intake air | Rotronic Hydroclip | Type S | 0 to 100 % rH | | +/- 1.5 % |

Fuel Characteristics

| Fuel type | | | | | |
|------------------------------------|----------|--------------------------|--------------------------------|-------|--------|
| Fuel properties: DIN EN 590 | | | | | |
| Density | | | Fuel elemental analysis | | |
| Viscosity | ISO 3675 | 831.4 kg/l | Carbon | 86.45 | % mass |
| | ISO 3104 | 2.379 mm ² /s | Hydrogen | 13.54 | % mass |
| | | | Nitrogen | < 0.1 | % mass |
| | | | Oxygen | < 0.1 | % mass |
| | | | Sulphur | < 1.0 | % mass |

* If Applicable

Ambient and Gaseous Emissions Data*

| Emissions Test Report No.: | | | | | | | | | Sheet 4/5 |
|------------------------------------|-----|-----|-----|-----|---------|---------|---------|----------|--------------|
| Mode | 1 | 2 | 3 | 4 | 5 | 6 | 7 | 8 | |
| Power/Torque % | 100 | 75 | 50 | 10 | 100 | 75 | 50 | 0 | |
| Speed % | 100 | 100 | 100 | 100 | Peak T. | Peak T. | Peak T. | Low Idle | |
| Time at beginning of mode hh:mm | NA | NA | NA | NA | NA | NA | NA | NA | NA |

| Ambient Data | | | | | | | | | |
|---------------------------|---------|---------|---------|---------|---------|---------|---------|--------|--|
| Atmospheric pressure kPa | 100.108 | 100.108 | 100.108 | 100.108 | 100.148 | 100.148 | 100.148 | 100.25 | |
| Intake air temperature °C | 25.5 | 25.5 | 25.6 | 25.2 | 24.9 | 24.8 | 25.4 | 25.4 | |
| Intake air humidity % | 57.9 | 55.1 | 51.0 | 50.2 | 56.0 | 52.5 | 48.1 | 39.2 | |
| Atmospheric factor (fa) | 1.008 | 1.007 | 1.007 | 1.004 | 1.004 | 1.003 | 1.005 | 1.002 | |

| Gaseous Emissions Data: | | | | | | | | | |
|---------------------------------|-------|-------|-------|-------|-------|-------|-------|-------|--|
| NOx concentration dry ppm | 785 | 761 | 651 | 240 | 1259 | 1305 | 1352 | 493 | |
| CO concentration dry ppm | 106 | 86 | 87 | 224 | 840 | 688 | 516 | 95 | |
| CO2 concentration dry % | 7.08 | 6.31 | 5.64 | 3.14 | 9.13 | 8.89 | 7.91 | 1.63 | |
| O2 concentration dry % | 10.64 | 11.86 | 12.83 | 16.69 | 7.48 | 8.0 | 9.58 | 18.85 | |
| HC concentration wet ppm | 25 | 35 | 32 | 88 | 12 | 17 | 31 | 67 | |
| NOx humidity correction factor | 1.024 | 1.012 | 0.997 | 0.990 | 1.008 | 0.993 | 0.984 | 0.953 | |
| Fuel specification factor (FFH) | 1.826 | 1.834 | 1.839 | 1.863 | 1.808 | 1.811 | 1.820 | 1.877 | |
| Dry/wet correction factor | 0.915 | 0.923 | 0.931 | 0.955 | 0.898 | 0.902 | 0.912 | 0.973 | |
| NOx mass flow kg/hr | 2.787 | 2.239 | 1.487 | .374 | 2.704 | 2.157 | 1.729 | .235 | |
| CO mass flow kg/hr | 0.245 | 0.166 | 0.130 | 0.225 | 1.211 | 0.783 | 0.456 | 0.030 | |
| CO2 mass flow kg/hr | N/A | N/A | N/A | N/A | N/A | N/A | N/A | N/A | |
| O2 mass flow kg/hr | N/A | N/A | N/A | N/A | N/A | N/A | N/A | N/A | |
| HC mass flow kg/hr | 0.026 | 0.031 | 0.022 | 0.042 | 0.008 | 0.008 | 0.012 | 0.010 | |
| SO2 mass flow kg/hr | N/A | N/A | N/A | N/A | N/A | N/A | N/A | N/A | |
| NOx specific g/kW hr | 7.47 | 7.99 | 7.95 | 10.0 | 8.5 | 9.0 | 10.87 | 100.5 | |

* If applicable

Engine Test Data*

| Emissions Test Report No.: C15-1 | | | | | | | | Sheet 5/5 | |
|-------------------------------------|---|-----|-----|-----|-----|---------|---------|--------------|----------|
| Mode | 1 | 2 | 3 | 4 | 5 | 6 | 7 | 8 | |
| Power/Torque | % | 100 | 75 | 50 | 10 | 100 | 75 | 50 | 0 |
| Speed | % | 100 | 100 | 100 | 100 | Peak T. | Peak T. | Peak T. | Low Idle |
| Time at beginning of mode | | NA | NA | NA | NA | NA | NA | NA | NA |

| Engine Data | | | | | | | | | |
|------------------------------------|--------|-------|-------|--------|--------|--------|--------|--------|--------|
| Speed | rpm | 2100 | 2100 | 2100 | 2100 | 1400 | 1400 | 1400 | 800 |
| Auxiliary power | kW | 0 | 0 | 0 | 0 | 0 | 0 | 0 | 0 |
| Dynamometer setting | Nm | 1694 | 1269 | 845 | 171 | 2330 | 1749 | 1163 | 11 |
| Power | kW | 372.5 | 278.9 | 185.9 | 37.6 | 341.6 | 256.4 | 170.5 | 0.7 |
| Mean effective pressure | bar | 6.654 | 4.983 | 3.321 | 0.672 | 9.151 | 6.868 | 4.569 | 0.042 |
| Fuel rack | mm | 3.876 | 1.141 | -1.337 | -5.022 | 4.108 | 1.791 | -0.753 | -4.914 |
| Uncorrected spec. fuel consumption | g/kWhr | 216 | 214 | 224 | 484 | 204 | 205 | 209 | 1031 |
| Fuel flow | kg/hr | 81.7 | 60.4 | 42.2 | 15.5 | 65.8 | 49.5 | 33.5 | 2.4 |
| Air flow | kg/hr | 2305 | 1925 | 1499 | 1032 | 1426 | 1120 | 858 | 322 |
| Exhaust flow (gexhw) | kg/hr | 2387 | 1985 | 1541 | 1048 | 1492 | 1170 | 892 | 324.4 |
| Exhaust temperature | °C | 519 | 461 | 417 | 281 | 601 | 567 | 503 | 140 |
| Exhaust back pressure | mbar | 75.2 | 46.4 | 26.5 | 9.2 | 27.5 | 16.7 | 8.4 | 2.8 |
| Cylinder Coolant temperature out | °C | 84.7 | 84.0 | 84.1 | 83.1 | 85.6 | 84.8 | 84.1 | 82.8 |
| Cylinder Coolant temperature in | °C | NA | NA | NA | NA | NA | NA | NA | NA |
| Cylinder Coolant pressure | bar | 1.57 | 1.58 | 1.58 | 1.58 | 0.7409 | 0.7428 | 0.7455 | 0.2902 |
| Temperature intercooled air | °C | 93.8 | 87.1 | 81.8 | 78.3 | 84.5 | 80.1 | 78.3 | 76.9 |
| Lubricant temperature | °C | 96.7 | 95.4 | 94.1 | 92.2 | 93.6 | 91.9 | 91.0 | 85.0 |
| Lubricant pressure | bar | 4.02 | 4.08 | 4.16 | 4.26 | 3.83 | 3.90 | 3.95 | 3.6287 |
| Inlet depression | mbar | 40.3 | 31.6 | 39.5 | 39.4 | 41.78 | 45.48 | 37.58 | 35.1 |

* If applicable

** Before functional thermostat

STATEMENT OF COMPLIANCE WITH THE NO_x TECHNICAL CODE

THIS STATEMENT OF COMPLIANCE SHALL BE SUPPLEMENTED BY A RECORD OF CONSTRUCTION,
TECHNICAL FILE AND MEANS OF VERIFICATION
ISSUED TO DOCUMENT COMPLIANCE WITH REGULATION 13 OF ANNEX VI TO MARPOL 73/78
AT THE REQUEST OF

Caterpillar

Engine Builder

by J.M. Kelly
Surveyor, American Bureau of Shipping

| Engine Manufacturer | Model Number | Serial Number | Test Cycle(s) | Rated Power (kW) And Speed (RPM) | Engine Approval Number |
|---------------------|--------------------|---------------|---------------|----------------------------------|---------------------------|
| Caterpillar | 3412C (0K-2777) | 38S25392 | C1 | 567 kW @ 2100RPM | ABSHS-NTC-1049-0004-00198 |

THIS IS TO CERTIFY:

1. That the above-mentioned marine diesel engine has been surveyed for pre-certification in accordance with the requirements of the Technical Code on Control of Emission of Nitrogen Oxides from Marine Diesel Engines made mandatory by Annex VI of the Convention; and
2. That the pre-certification survey shows that the engine, its components, adjustable features, and Technical File, prior to the engine's installation and/or service on board a ship, fully comply with the applicable requirements of regulation 13 of Annex VI of the Convention.

This Statement of Compliance is valid for the life of the engine, subject to the engine being operated and maintained in accordance with the relevant sections of the ABS approved Technical File.

This Certificate is valid only when "Supplement to Statement of Compliance" issued at Chicago, Illinois USA on 19 October 2009 is attached.

Issued at Chicago, Illinois USA 19 October 2009
(Place of issue) (Date of issue)



J.M. Kelly
J.M. Kelly
Surveyor, American Bureau of Shipping

This Statement of Compliance evidences ABS' evaluation of compliance with one or more of the requirements of an IMO Convention, as interpreted by ABS, as of the date of its issuance or endorsement and is issued solely for the use of its client. This Statement of Compliance is a representation only that the vessel, equipment, structure, item of material, machinery or any other item covered by this Statement of Compliance has met one or more of the requirements of an IMO Convention, as interpreted by ABS. The validity, applicability and interpretation of this Statement of Compliance is governed by ABS, which shall remain the sole judge thereof. Nothing contained in this Statement of Compliance shall be deemed to relieve any designer, builder, owner, manufacturer, seller, supplier, repairer operator or other entity of any warranty, express or implied. This Statement of Compliance is not an IMO Convention Certificate issued under the authority of a government.

SUPPLEMENT TO STATEMENT OF COMPLIANCE WITH THE NO_x TECHNICAL CODE

RECORD OF CONSTRUCTION, TECHNICAL FILE AND MEANS OF VERIFICATION

In respect of the provisions of Annex VI of the International Convention for the Prevention of Pollution from Ships, 1973, as modified by the Protocols of 1978 and 1997 relating thereto (hereinafter referred to as "the Convention") and of the Technical Code on Control of Emission of Nitrogen Oxides from Marine Diesel Engines (hereinafter referred to as the "NO_x Technical Code").

Notes:

1. This Record and its attachments shall be permanently attached to the Statement of Compliance with the NO_x Technical Code. The Statement of Compliance with the NO_x Technical Code shall accompany the engine throughout its life and shall be available on board the ship at all times.
2. If the language of the original Record is neither English nor French, the text shall include a translation into one of these languages.
3. Unless otherwise stated, regulations mentioned in this Record refer to regulations of Annex VI of the Convention and the requirements for an engine's Technical File and Means of Verification refer to mandatory requirements of the NO_x Technical Code.

1 Particulars of the engine

1.1 Name and address of manufacturer

| | |
|---------|---|
| Name | Caterpillar, Inc. |
| Address | 100 N.E. Adams Street Peoria, IL 47905, U.S.A. |

1.2 Place of engine build Caterpillar Inc., Route 29 and Galena Road, Mossville, IL 61552

1.3 Date of engine build 25 June 2009

1.4 Place of pre-certification survey Caterpillar Inc., Route 29 and Galena Road, Mossville, IL 61552

1.5 Date of pre-certification survey 18 August 2009

1.6 Engine type and model number Caterpillar Model: 3412C (0K-2777)

1.7 Engine serial number 38S25392

1.8 If applicable, the engine is a parent engine or a member engine of the following engine family or engine group

C1 Cycle: Variable Speed and Variable Load

1.9 Test cycle(s) (see chapter 3 of the NO_x Technical Code) Auxiliary Engine Application

1.10 Rated Power (kW) and Speed (RPM) 567 kW @ 2100 RPM

1.11 Engine approval number ABSHS-NTC-1049-0004-00198

1.12 Specification(s) of test fuel ISO 8217, DMX

1.13 NO_x reducing device designated approval number (if installed) N/A

1.14 Applicable NO_x Emission Limit (g/kWh) (regulation 13 of Annex VI) 9.8

1.15 Engine's actual NO_x Emission Value (g/kWh) 8.5

2 Particulars of the Technical File*

2.1 Technical File identification/approval number ABSHS-NTC-1049-0004-00198

2.2 Technical File approval date 19 October 2009

* The Technical File, as required by chapter 2 of NO_x Technical Code, is an essential part of the Statement of Compliance with the NO_x Technical Code and must always accompany an engine throughout its life and always be available on board a ship.

3 Specifications for the On-board NO_x Verification Procedures for the Engine Parameter Survey**

3.1 On-board NO_x verification procedures identification/approval number ABSHS-NTC-1049-0004-00198

3.2 On-board NO_x verification procedures approval date 19 October 2009

** The specifications for the on-board NO_x verification procedures, as required by chapter 6 of the NO_x Technical Code, is an essential part of the Statement of Compliance with the NO_x Technical Code and must always accompany an engine through its life and always be available on board a ship.

THIS IS TO CERTIFY that this Record is correct in all respects.

Issued at Chicago, Illinois USA the 19 October 2009



J.M. Kelly
Surveyor, American Bureau of Shipping



AMERICAN BUREAU OF SHIPPING

| | | | |
|------------------|-------------------------|--------------------|---------------------|
| Customer Name | CATERPILLAR INC. | Purchase Order No. | |
| Attending Office | Chicago, IL | Report Number | CH1735601.R1 |
| First Visit Date | 30-Sep-2009 | Last Visit Date | 30-Sep-2009 |

Certification Of: Diesel Engine Quantity: One (1)
 Manufacturer: CATERPILLAR INC.

Survey Location : ABS chicago

Equipment Data

Item Name Diesel Engine
 Designer Name "HYS298"
 Purchaser Name Hyundai Heavy Ind.

Design Details

Design State Type Approved
 ABS Reviewing Organization Houston SED - Ship Equipment
 Drawing Number 3406C OK-2777

This is to Certify that the undersigned surveyor(s) to this Bureau did, at the request of the customer, carry out the following survey and report as follows:

The principal data has been verified in accordance with the applicable Rules/specifications and approved plans, and confirmed to be within acceptable tolerances.

**Surveyor(s) to The American Bureau of Shipping
 Attending Surveyors**

Kelly Joseph M

Reviewed By

NOTE: This report evidences that the survey reported herein was carried out in compliance with one or more of the Rules, guides, standards or other criteria of the American Bureau of Shipping and is issued solely for the use of the Bureau, its committees, its clients or other authorized entities. This Report is a representation only that the vessel, structure, item or material equipment, machinery or any other item covered by this Report has been examined for compliance with, or has met one or more of the Rules, guides, standards or other criteria of American Bureau of Shipping. The validity, applicability and interpretation of this report is governed by the Rules and standards of American Bureau of Shipping who shall remain the sole judge thereof. Nothing contained in this Report or in any notation made in the contemplation of this Report shall be deemed to relieve any designer, builder, owner, manufacturer, seller, supplier, repairer, operator or other entity of any warranty express or implied.