

# *Grizzly* **Industrial, Inc.**®

## **MODEL G0623X/G0623X3 10" SLIDING TABLE SAW**

### **OWNER'S MANUAL**

*(For models manufactured since 05/22)*



G0623X ONLY



181721

COPYRIGHT © NOVEMBER, 2007 BY GRIZZLY INDUSTRIAL, INC., REVISED JULY, 2022 (KS)

**WARNING: NO PORTION OF THIS MANUAL MAY BE REPRODUCED IN ANY SHAPE  
OR FORM WITHOUT THE WRITTEN APPROVAL OF GRIZZLY INDUSTRIAL, INC.**

#TR9147 PRINTED IN TAIWAN

V6.07.22

**\*\*\*Keep for Future Reference\*\*\***

 **WARNING!**

**This manual provides critical safety instructions on the proper setup, operation, maintenance, and service of this machine/tool. Save this document, refer to it often, and use it to instruct other operators.**

**Failure to read, understand and follow the instructions in this manual may result in fire or serious personal injury—including amputation, electrocution, or death.**

**The owner of this machine/tool is solely responsible for its safe use. This responsibility includes but is not limited to proper installation in a safe environment, personnel training and usage authorization, proper inspection and maintenance, manual availability and comprehension, application of safety devices, cutting/sanding/grinding tool integrity, and the usage of personal protective equipment.**

**The manufacturer will not be held liable for injury or property damage from negligence, improper training, machine modifications or misuse.**

 **WARNING!**

**Some dust created by power sanding, sawing, grinding, drilling, and other construction activities contains chemicals known to the State of California to cause cancer, birth defects or other reproductive harm. Some examples of these chemicals are:**

- **Lead from lead-based paints.**
- **Crystalline silica from bricks, cement and other masonry products.**
- **Arsenic and chromium from chemically-treated lumber.**

**Your risk from these exposures varies, depending on how often you do this type of work. To reduce your exposure to these chemicals: Work in a well ventilated area, and work with approved safety equipment, such as those dust masks that are specially designed to filter out microscopic particles.**

# Table of Contents

<b>INTRODUCTION</b> .....	<b>2</b>	<b>SECTION 6: ACCESSORIES</b> .....	<b>62</b>
Contact Info.....	2	<b>SECTION 7: MAINTENANCE</b> .....	<b>66</b>
Manual Accuracy .....	2	Schedule.....	66
Identification.....	3	Cleaning.....	66
Machine Data Sheets .....	4	Unpainted Cast Iron.....	66
<b>SECTION 1: SAFETY</b> .....	<b>8</b>	Lubrication .....	67
Safety Instructions for Machinery .....	8	<b>SECTION 8: SERVICE</b> .....	<b>68</b>
Additional Safety for Sliding Table Saws.....	10	Troubleshooting .....	68
Preventing Kickback .....	11	Belt Replacement.....	70
Protecting Yourself From Kickback.....	11	Blade Tilt Calibration.....	71
Glossary of Terms .....	12	Sliding Table Parallel Adjustment.....	72
<b>SECTION 2: POWER SUPPLY</b> .....	<b>13</b>	Sliding Table Adjustment.....	73
G0623X3 440V Voltage Conversion.....	16	Squaring Crosscut Fence to Blade.....	74
<b>SECTION 3: SETUP</b> .....	<b>17</b>	Splitter/Riving Knife Mounting Block.....	75
Needed for Setup.....	17	<b>SECTION 9: WIRING</b> .....	<b>76</b>
Unpacking .....	17	Wiring Safety Instructions .....	76
Inventory .....	18	G0623X Wiring Diagram.....	77
Hardware Recognition Chart .....	20	G0623X3 7.5 HP 220V Wiring Diagram .....	78
Cleanup.....	21	G0623X3 7.5 HP 440V Wiring Diagram .....	79
Site Considerations.....	22	<b>SECTION 10: PARTS</b> .....	<b>80</b>
Lifting & Placing.....	23	Cabinet.....	80
Assembly .....	24	Main Trunnion.....	81
Power Connection.....	32	Main Motor.....	82
Test Run .....	33	Sliding Table .....	84
<b>SECTION 4: OPERATIONS</b> .....	<b>35</b>	Tables .....	86
Operation Overview .....	35	Rip Fence.....	87
Workpiece Inspection.....	36	Handwheels .....	88
Non-Through & Through Cuts .....	36	Scoring Trunnion.....	89
Blade Guard & Splitter/Riving Knife.....	37	Crosscut Table.....	90
Safety Tips.....	40	Swing Arm.....	91
Blade Requirements .....	40	Miter Gauge .....	92
Blade Selection.....	40	Crosscut Fence.....	93
Changing Main Blade .....	42	Labels & Cosmetics .....	94
Changing/Adjusting Scoring Blade .....	43	<b>WARRANTY</b> .....	<b>97</b>
Rip Cutting .....	44		
Crosscutting.....	46		
Miter Cutting.....	48		
Dado Cutting.....	49		
Rabbet Cutting.....	51		
Resawing .....	53		
<b>SECTION 5: SHOP-MADE ACCESSORIES</b> .....	<b>55</b>		
Featherboards.....	55		
Push Sticks .....	58		
Push Blocks .....	59		
Zero-Clearance Insert.....	60		
Outfeed Table .....	61		

# INTRODUCTION

## Contact Info

We stand behind our machines! If you have questions or need help, contact us with the information below. Before contacting, make sure you get the **serial number** and **manufacture date** from the machine ID label. This will help us help you faster.

Grizzly Technical Support  
1815 W. Battlefield  
Springfield, MO 65807  
Phone: (570) 546-9663  
Email: techsupport@grizzly.com

We want your feedback on this manual. What did you like about it? Where could it be improved? Please take a few minutes to give us feedback.

Grizzly Documentation Manager  
P.O. Box 2069  
Bellingham, WA 98227-2069  
Email: manuals@grizzly.com

### **WARNING**

Like all machinery there is potential danger when operating this machine. Accidents are frequently caused by lack of familiarity or failure to pay attention. Use this machine with respect and caution to decrease the risk of operator injury. If normal safety precautions are overlooked or ignored, serious personal injury may occur.

### **CAUTION**

No list of safety guidelines can be complete. Every shop environment is different. Always consider safety first, as it applies to your individual working conditions. Use this and other machinery with caution and respect. Failure to do so could result in serious personal injury, damage to equipment, or poor work results.

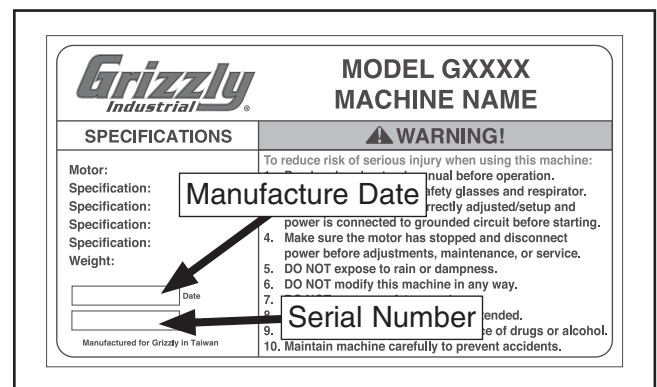
## Manual Accuracy

We are proud to provide a high-quality owner's manual with your new machine!

We made every effort to be exact with the instructions, specifications, drawings, and photographs in this manual. Sometimes we make mistakes, but our policy of continuous improvement also means that **sometimes the machine you receive is slightly different than shown in the manual.**

If you find this to be the case, and the difference between the manual and machine leaves you confused or unsure about something, check our website for an updated version. We post current manuals and manual updates for free on our website at [www.grizzly.com](http://www.grizzly.com).

Alternatively, you can call our Technical Support for help. Before calling, make sure you write down the **manufacture date** and **serial number** from the machine ID label (see below). This information is required for us to provide proper tech support, and it helps us determine if updated documentation is available for your machine.



Grizzly Industrial		MODEL GXXXX MACHINE NAME
SPECIFICATIONS		<b>WARNING!</b>
Motor:		To reduce risk of serious injury when using this machine:
Specification:		1. Read manual before operation.
Specification:		2. Wear safety glasses and respirator.
Specification:		3. Make sure power is connected to grounded circuit before starting.
Specification:		4. Make sure the motor has stopped and disconnect power before adjustments, maintenance, or service.
Weight:		5. DO NOT expose to rain or dampness.
		6. DO NOT modify this machine in any way.
		7.
		8.
		9.
		10. Maintain machine carefully to prevent accidents.

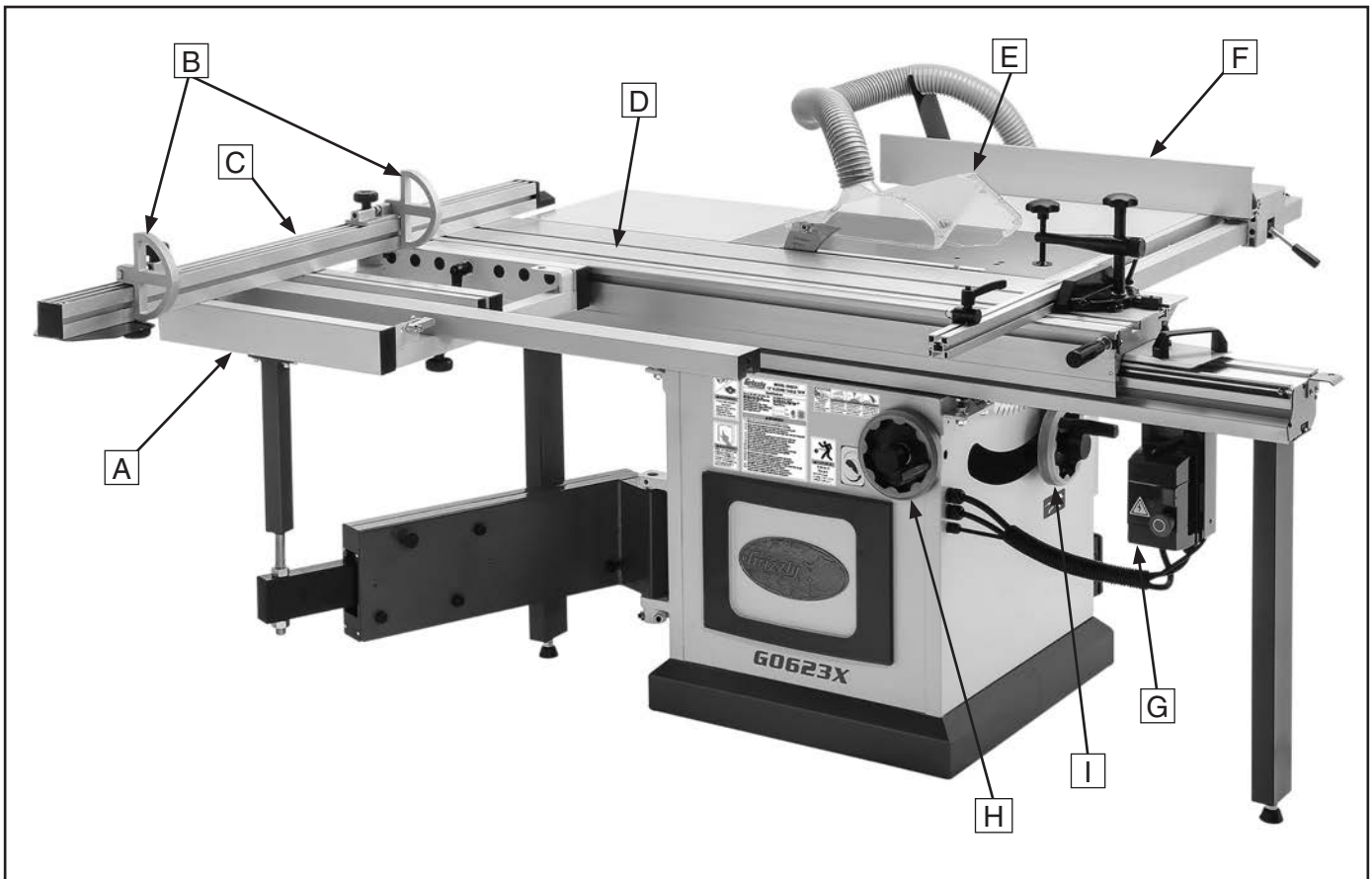
Manufacture Date: \_\_\_\_\_

Serial Number: \_\_\_\_\_

Manufactured for Grizzly in Taiwan



# Identification



- A. Crosscut Table:** Provides a wide, stable platform for supporting full-size panels during crosscutting operations.
- B. Flip Stops:** Used for quick measurements for crosscutting.
- C. Crosscut Fence:** Used during crosscutting operations. Features a scale and multiple flip-style stop blocks for precise, repeatable crosscutting operations.
- D. Sliding Table:** Glides workpiece through blade with effortless precision and ease.
- E. Blade Guard:** Fully-adjustable blade guard maintains maximum protection around saw blade, and a 2½" dust port effectively extracts dust from cutting operation.
- F. Rip Fence:** Fully adjustable with micro-adjustment knob for precision adjustments. Fence face can be positioned for standard cutting operations, or in lower position for blade guard clearance during narrow ripping operations.
- G. Magnetic ON/OFF Switch:** Green start button turns motor **ON**. Red Emergency Stop button turns motor **OFF**; for safety purposes, this button will remain depressed and prevent restarting until reset. Reset by rotating clockwise until it pops out.
- H. Blade Angle Handwheel:** Adjusts angle of saw blades.
- I. Blade Elevation Handwheel:** Adjusts height of main saw blade.



# MODEL G0623X & G0623X3 10" SLIDING TABLE SAW SPECIFICATIONS

Model Number	G0623X	G0623X3
<b>Product Dimensions</b>		
Weight	533 lbs	
Width (side-to-side)/Depth (front-to-back)/Height	76 x 125 x 46 in.	
Foot Print (Width/Depth)	25-1/2 x 28 in.	25-1/2 x 28 in.
<b>Shipping Dimensions</b>		
<b>Carton 1</b>		
Type	Wood Crate	
Content	Machine	
Weight	570 lbs.	556 lbs.
Width (side-to-side)/Depth (front-to-back)/Height	45 x 42 x 42 in.	
<b>Carton 2</b>		
Type	Cardboard	
Content	Sliding Table & Fence	
Weight	118 lbs.	
Width (side-to-side)/Depth (front-to-back)/Height	66 x 18 x 9 in.	
<b>Electrical</b>		
Power Requirement	230V, Single-Phase, 60 Hz	220V or 440V, 3-Phase, 60 Hz
Prewired Voltage	230V	220V
Full-Load Current Rating	19A	18A @ 220V, 9A at 440V
Minimum Circuit Size	30A	30A @ 220V, 15A @ 440V
Switch	Magnetic with Thermal Overload Protection	
Power Cord	"S"-Type, 3-Wire, 12 AWG, 300 VAC	Recommend "S"-Type, 4-Wire, 10 AWG, 300 VAC for 220V; Permanent Connection for 440V
Plug Included	Yes	No
Plug/Outlet Type	L6-30	Recommend L15-30 for 220V; Permanent Connection for 440V
Voltage Conversion Kit	Not Applicable	Requires Part# G440VG0623X3
Recommended Phase Converter	Not Applicable	G5845
<b>Main Motor</b>		
Type	TEFC Capacitor-Start Induction	TEFC Induction
Horsepower	5 HP	7.5 HP
Voltage	230V	220V/440V
Prewired	Not Applicable	220V
Phase	Single-Phase	3-Phase
Amps	19A	18A @ 220V, 9A @ 440V
Speed	3450 RPM	
Centrifugal Switch/Contacts	External	
Power Transfer	V-Belt Drive	
Bearings	Sealed and Lubricated	



<b>Model Number</b>	<b>G0623X</b>	<b>G0623X3</b>
<b>Operation Information</b>		
Main Blade Size	10 in.	
Main Arbor Size	5/8 in.	
Scoring Blade Size	3-1/8 in.	
Scoring Blade Arbor Size	22mm	
Maximum Width of Dado	13/16 in.	
Main Blade Tilt	0 - 45 deg	
Main Blade Speed	4000 RPM	
Scoring Blade Tilt	0 - 45 deg	
Scoring Blade Speed	8000 RPM	
<b>Cutting Capacities</b>		
Max Depth of Cut At 90 Deg	3-1/8 in.	
Max Depth of Cut At 45 Deg	2-1/4 in.	
Table With Rip Fence Max Cut Width	33 in.	
Sliding Table With Cross Fence Max Cut Width	78-1/2 in.	
Sliding Table With Cross Fence Max Cut Length	63 in.	
Miter Fence Cut Width At 45 Deg	63 in.	
<b>Table Information</b>		
Floor To Table Height	33-5/8 in.	
Table Size Length	27 in.	
Table Size Width	14-3/8 in.	
Table Size Thickness	2 in.	
Table Size With Ext Wings Length	47 in.	
Table Size With Ext Wings Width	40 in.	
Table Size With Ext Wings Thickness	2 in.	
Sliding Table Length	63 in.	
Sliding Table Width	12-1/4 in.	
Sliding Table Thickness	3-1/2 in.	
Sliding Table T-Slot Top Width	5/8 in.	
Sliding Table T-Slot Height	1/2 in.	
Sliding Table T-Slot Bottom Width	1-1/4 in.	
<b>Fence Information</b>		
Fence Type	Single Lever Locking, Extruded Aluminum	
Fence Size Length	33-1/2 in.	
Fence Size Width	2 in.	
Fence Size Height	4-1/4 in.	
Fence Stops	2	



<b>Model Number</b>	<b>G0623X</b>	<b>G0623X3</b>
<b>Construction Materials</b>		
Table	Precision-Ground Cast Iron	
Sliding Table	Aluminum	
Cabinet	Steel	
Rip Fence Rails	Extruded Aluminum	
Guard	Plastic	
Spindle Bearing Type	Sealed & Permanently Lubricated	
Cabinet Paint Type/Finish	Powder Coated	
<b>Other Related Information</b>		
No of Dust Ports	2	
Dust Port Size	4, 2-1/2 in.	
<b>Other Specifications</b>		
Country of Origin	Taiwan	
Warranty	1 Year	
Approximate Setup Time	1-1/2 Hours	
Serial Number Location	ID Label	
ISO 9001 Factory	Yes	



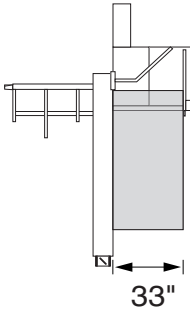
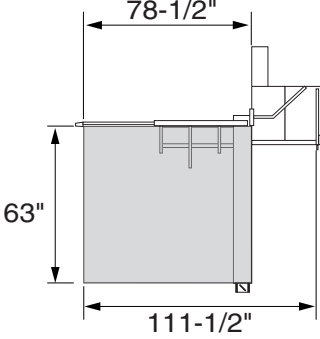
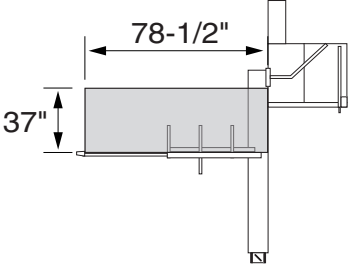
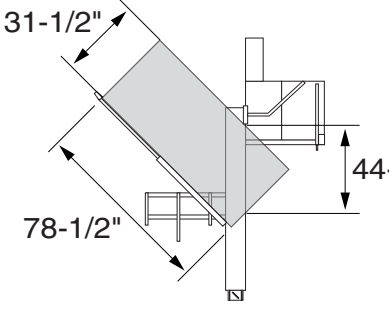
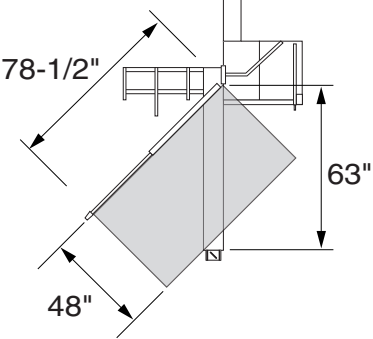
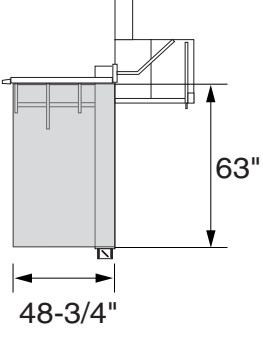
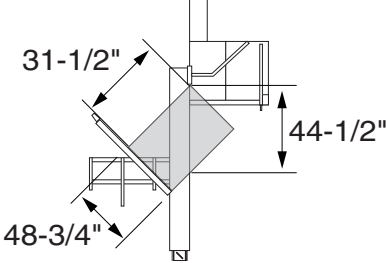
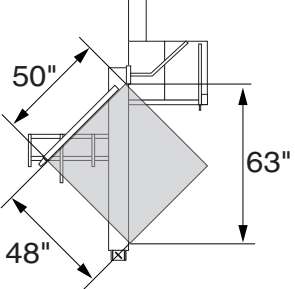




# SLIDING TABLE SAW CAPACITIES

Customer Service #: (570) 546-9663 • To Order Call: (800) 523-4777 • Fax #: (800) 438-5901

## MODEL G0623X/G0623X3 10" SLIDING TABLE SAW

 <p>Ripping Width</p>	 <p>Cross Cut</p>
 <p>Miter Cut 90° (push cut)</p>	 <p>Miter Cut 45° (push cut)</p>
 <p>Miter Cut 45°</p>	 <p>Cross Cut (fence not extended)</p>
 <p>Miter Cut 45° (push cut, fence not extended)</p>	 <p>Miter Cut 45° (fence not extended)</p>



# SECTION 1: SAFETY

## For Your Own Safety, Read Instruction Manual Before Operating This Machine

The purpose of safety symbols is to attract your attention to possible hazardous conditions. This manual uses a series of symbols and signal words intended to convey the level of importance of the safety messages. The progression of symbols is described below. Remember that safety messages by themselves do not eliminate danger and are not a substitute for proper accident prevention measures. Always use common sense and good judgment.

**⚠ DANGER** Indicates an imminently hazardous situation which, if not avoided, **WILL** result in death or serious injury.

**⚠ WARNING** Indicates a potentially hazardous situation which, if not avoided, **COULD** result in death or serious injury.

**⚠ CAUTION** Indicates a potentially hazardous situation which, if not avoided, **MAY** result in minor or moderate injury. It may also be used to alert against unsafe practices.

**NOTICE** Alerts the user to useful information about proper operation of the machine to avoid machine damage.

## Safety Instructions for Machinery

### ⚠ WARNING

**OWNER'S MANUAL.** Read and understand this owner's manual **BEFORE** using machine.

**TRAINED OPERATORS ONLY.** Untrained operators have a higher risk of being hurt or killed. Only allow trained/supervised people to use this machine. When machine is not being used, disconnect power, remove switch keys, or lock-out machine to prevent unauthorized use—especially around children. Make your workshop kid proof!

**DANGEROUS ENVIRONMENTS.** Do not use machinery in areas that are wet, cluttered, or have poor lighting. Operating machinery in these areas greatly increases the risk of accidents and injury.

**MENTAL ALERTNESS REQUIRED.** Full mental alertness is required for safe operation of machinery. Never operate under the influence of drugs or alcohol, when tired, or when distracted.

**ELECTRICAL EQUIPMENT INJURY RISKS.** You can be shocked, burned, or killed by touching live electrical components or improperly grounded machinery. To reduce this risk, only allow qualified service personnel to do electrical installation or repair work, and always disconnect power before accessing or exposing electrical equipment.

**DISCONNECT POWER FIRST.** Always disconnect machine from power supply **BEFORE** making adjustments, changing tooling, or servicing machine. This prevents an injury risk from unintended startup or contact with live electrical components.

**EYE PROTECTION.** Always wear ANSI-approved safety glasses or a face shield when operating or observing machinery to reduce the risk of eye injury or blindness from flying particles. Everyday eyeglasses are **NOT** approved safety glasses.



# WARNING

**WEARING PROPER APPAREL.** Do not wear clothing, apparel or jewelry that can become entangled in moving parts. Always tie back or cover long hair. Wear non-slip footwear to reduce risk of slipping and losing control or accidentally contacting cutting tool or moving parts.

**HAZARDOUS DUST.** Dust created by machinery operations may cause cancer, birth defects, or long-term respiratory damage. Be aware of dust hazards associated with each workpiece material. Always wear a NIOSH-approved respirator to reduce your risk.

**HEARING PROTECTION.** Always wear hearing protection when operating or observing loud machinery. Extended exposure to this noise without hearing protection can cause permanent hearing loss.

**REMOVE ADJUSTING TOOLS.** Tools left on machinery can become dangerous projectiles upon startup. Never leave chuck keys, wrenches, or any other tools on machine. Always verify removal before starting!

**USE CORRECT TOOL FOR THE JOB.** Only use this tool for its intended purpose—do not force it or an attachment to do a job for which it was not designed. Never make unapproved modifications—modifying tool or using it differently than intended may result in malfunction or mechanical failure that can lead to personal injury or death!

**AWKWARD POSITIONS.** Keep proper footing and balance at all times when operating machine. Do not overreach! Avoid awkward hand positions that make workpiece control difficult or increase the risk of accidental injury.

**CHILDREN & BYSTANDERS.** Keep children and bystanders at a safe distance from the work area. Stop using machine if they become a distraction.

**GUARDS & COVERS.** Guards and covers reduce accidental contact with moving parts or flying debris. Make sure they are properly installed, undamaged, and working correctly **BEFORE** operating machine.

**FORCING MACHINERY.** Do not force machine. It will do the job safer and better at the rate for which it was designed.

**NEVER STAND ON MACHINE.** Serious injury may occur if machine is tipped or if the cutting tool is unintentionally contacted.

**STABLE MACHINE.** Unexpected movement during operation greatly increases risk of injury or loss of control. Before starting, verify machine is stable and mobile base (if used) is locked.

**USE RECOMMENDED ACCESSORIES.** Consult this owner's manual or the manufacturer for recommended accessories. Using improper accessories will increase the risk of serious injury.

**UNATTENDED OPERATION.** To reduce the risk of accidental injury, turn machine **OFF** and ensure all moving parts completely stop before walking away. Never leave machine running while unattended.

**MAINTAIN WITH CARE.** Follow all maintenance instructions and lubrication schedules to keep machine in good working condition. A machine that is improperly maintained could malfunction, leading to serious personal injury or death.

**DAMAGED PARTS.** Regularly inspect machine for damaged, loose, or mis-adjusted parts—or any condition that could affect safe operation. Immediately repair/replace **BEFORE** operating machine. For your own safety, **DO NOT** operate machine with damaged parts!

**MAINTAIN POWER CORDS.** When disconnecting cord-connected machines from power, grab and pull the plug—**NOT** the cord. Pulling the cord may damage the wires inside. Do not handle cord/plug with wet hands. Avoid cord damage by keeping it away from heated surfaces, high traffic areas, harsh chemicals, and wet/damp locations.

**EXPERIENCING DIFFICULTIES.** If at any time you experience difficulties performing the intended operation, stop using the machine! Contact our Technical Support at (570) 546-9663.



# Additional Safety for Sliding Table Saws

## **WARNING**

Serious injury or death can occur from getting cut or having body parts, such as fingers, amputated by rotating saw blade. Workpieces thrown by kickback can strike operators or bystanders with deadly force. Flying particles from cutting operations or broken blades can cause eye injuries or blindness. To minimize risk of getting hurt or killed, anyone operating machine **MUST** completely heed hazards and warnings below.

**HAND & BODY POSITIONING.** Keep hands away from saw blade and out of blade path during operation, so they cannot slip accidentally into blade. Stand to side of blade path. Never reach around, behind, or over blade. Only operate at front of machine.

**BLADE GUARD.** Use blade guard for all cuts that allow it to be used safely. Make sure blade guard is installed and adjusted correctly. Promptly repair or replace if damaged. Re-install blade guard immediately after operations that require its removal.

**RIVING KNIFE.** Use riving knife for all cuts. Make sure riving knife is aligned and positioned correctly. Promptly repair or replace it if damaged.

**KICKBACK.** Kickback occurs when saw blade ejects workpiece back toward operator. Know how to reduce risk of kickback. Learn how to protect yourself if it does occur.

**WORKPIECE CONTROL.** Feeding workpiece incorrectly increases risk of kickback. Make sure workpiece is in stable position on tables and supported by rip fence or crosscut fence during cutting operation. Never start saw with workpiece touching blade. Allow blade to reach full speed before cutting. Only feed workpiece against direction of main blade rotation. Always use some type of guide to feed workpiece in a straight line. Never back workpiece out of cut or move it backwards or sideways after starting a cut. Feed cuts all the way through to completion. Never perform any operation “freehand”. Turn OFF saw and wait until blade is completely stopped before removing workpiece.

**FENCE ADJUSTMENTS.** Make sure rip fence remains properly adjusted and parallel with blade. Never move fence while blade is rotating. Adjusting fence during operation increases risk of crashing fence and sending metal fragments flying with deadly force at operator or bystanders. Only adjust fence when blade is completely stopped and saw is **OFF**. Always lock fence before using.

**PUSH STICKS/BLOCKS.** Use push sticks or push blocks whenever possible to keep your hands farther away from blade while cutting. In event of an accident these devices will often take damage that would have happened to hands/fingers.

**BLADE ADJUSTMENTS.** Adjusting blade height or tilt during operation increases risk of crashing blade and sending metal fragments flying with deadly force at operator or bystanders. Only adjust blade height and tilt when blade is completely stopped and saw is **OFF**.

**CHANGING BLADES.** Always disconnect power before changing blades. Changing blades while saw is connected to power greatly increases injury risk if saw is accidentally powered up.

**DAMAGED SAW BLADES.** Never use blades that have been dropped or otherwise damaged.

**CUTTING CORRECT MATERIAL.** Never cut materials not intended for this saw. Only cut natural and man-made wood products, laminate covered wood products, and some plastics. Cutting metal, glass, stone, tile, etc. increases risk of operator injury due to kickback or flying particles.



# Preventing Kickback

---

Below are ways to avoid the most common causes of kickback:

- Only cut workpieces with at least one smooth and straight edge. DO NOT cut excessively warped, cupped or twisted wood. If the workpiece warpage is questionable, always choose another workpiece.
- Never attempt freehand cuts. If the workpiece is not fed parallel with the blade, a kickback will likely occur. Always use the rip fence or crosscut fence to support the workpiece.
- Make sure the splitter/riving knife is aligned with the blade. A misaligned splitter/riving knife can cause the workpiece to catch or bind, increasing the chance of kickback. If you think that your splitter/riving knife is not aligned with the blade, check it immediately!
- Ensure that your table slides parallel with the blade; otherwise, the chances of kickback are greatly increased. Take the time to check and adjust the sliding table to be parallel with the blade.
- Do not remove the splitter/riving knife. The splitter/riving knife maintains the kerf in the workpiece, reducing the chance of kickback.
- Keep the blade guard installed and working correctly for all through cuts.
- Feed cuts through to completion. Anytime you stop feeding a workpiece in the middle of a cut, the chance of kickback is increased.
- Never move the workpiece backwards while cutting or try to back it out of a cut while the blade is moving. If you cannot complete a cut for some reason, stop the saw motor and allow the blade to completely stop moving before backing the workpiece out. Promptly fix the condition that prevented you from completing the cut, before starting the saw again.

# Protecting Yourself From Kickback

---

Even if you know how to prevent kickback, it may still happen. Here are some tips to protect yourself if kickback DOES occur:

- Stand to the side of the blade during every cut. If a kickback does occur, the thrown workpiece usually travels directly in front of the blade.
- Wear safety glasses or a face shield. In the event of a kickback, your eyes and face are the most vulnerable part of your body.
- Never, for any reason, place your hand behind the blade. Should kickback occur, your hand will be pulled into the blade, which could cause amputation.
- Use a push stick to keep your hands farther away from the moving blade. If a kickback occurs, the push stick will most likely take the damage that your hand would have received.
- Use featherboards or anti-kickback devices to assist with feeding and prevent or slow down kickback.

## **WARNING**

Statistics show that most common accidents among table saw users can be linked to kickback. Kickback is typically defined as the high-speed ejection of stock from the table saw toward its operator. In addition to the danger of the operator or others in the area being struck by the flying stock, it is often the case that the operator's hands are pulled into the blade during the kickback.



# Glossary of Terms

---

The following is a list of common definitions, terms and phrases used throughout this manual as they relate to this table saw and woodworking in general. Become familiar with these terms for assembling, adjusting or operating this machine.

**Arbor:** The metal shaft on which the blade is mounted.

**Bevel Edge Cut:** A cut made along the edge of a workpiece with the saw blade tilted between 0° and 45°. Refer to **Page 72** for more details.

**Blade Guard Assembly:** A safety device that mounts over the saw blade to help prevent accidental contact with the saw blade and to contain flying chips and dust. Refer to **Page 38** for more details.

**Crosscut:** Cutting operation in which the miter gauge is used to hold the workpiece while it is cut across its shortest width. Refer to **Page 47** for more details.

**Dado Blade:** Blade or set of blades that are used to cut grooves and rabbets.

**Dado Cut:** Cutting operation that uses a dado blade to cut a flat bottomed groove into the face of the workpiece. Refer to **Page 50** for more details.

**Featherboard:** Safety device used to keep the workpiece held firmly against the rip fence or table surface. Refer to **Page 56** for more details.

**Kerf:** The resulting cut or gap in the workpiece after the saw blade passes through during a cutting operation.

**Kickback:** An event in which the spinning blade ejects the workpiece toward the front of the saw at a high rate of speed.

**Non-Through Cut:** A cut in which the blade does not cut through the top of the workpiece. Refer to **Page 37** for more details.

**Parallel:** Being an equal distance apart at every point along two given lines or planes (i.e. the rip fence face is parallel to the face of the saw blade).

**Perpendicular:** Lines or planes that intersect and form right angles (i.e. the blade is perpendicular to the table surface).

**Push Stick:** Safety device used to push the workpiece through a cutting operation. Used most often when rip cutting thin workpieces. Refer to **Page 59** for more details.

**Rabbet:** Cutting operation that creates an L-shaped channel along the edge of the workpiece. Refer to **Page 52** for more details.

**Rip Cut:** Cutting operation in which the rip fence is used to cut across the widest width of the workpiece. Refer to **Page 45** for more details.

**Splitter/Riving Knife:** Curved metal plate located behind the blade. Maintains kerf opening in wood when performing a cutting operation. Acts as a barrier behind blade to shield hands from being pulled into the blade if a kickback occurs. Refer to **Page 40** for more details.

**Straightedge:** A tool used to check the flatness, parallelism, or consistency of a surface(s).

**Thin Kerf Blade:** A blade with a kerf or thickness that is thinner than a standard blade cannot be used on this saw.

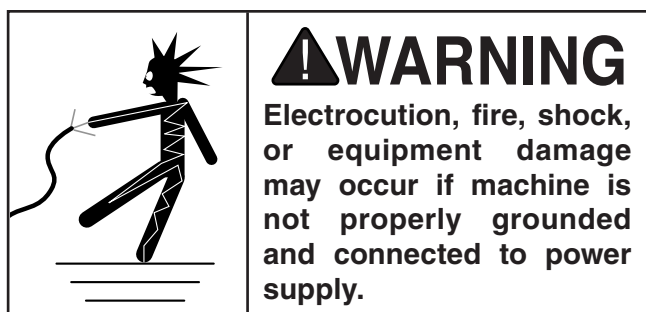
**Through Cut:** A cut in which the blade cuts completely through the workpiece (refer to **Page 37**).



# SECTION 2: POWER SUPPLY

## Availability

Before installing the machine, consider the availability and proximity of the required power supply circuit. If an existing circuit does not meet the requirements for this machine, a new circuit must be installed. To minimize the risk of electrocution, fire, or equipment damage, installation work and electrical wiring must be done by an electrician or qualified service personnel in accordance with all applicable codes and standards.



## Full-Load Current Rating

The full-load current rating is the amperage a machine draws at 100% of the rated output power. On machines with multiple motors, this is the amperage drawn by the largest motor or sum of all motors and electrical devices that might operate at one time during normal operations.

**G0623X at 230V, 1-Ph..... 19 Amps**

**G0623X3 at 220V, 3-Ph..... 18 Amps**

**G0623X3 at 440V, 3-Ph..... 9 Amps**

The full-load current is not the maximum amount of amps that the machine will draw. If the machine is overloaded, it will draw additional amps beyond the full-load rating.

If the machine is overloaded for a sufficient length of time, damage, overheating, or fire may result—especially if connected to an undersized circuit. To reduce the risk of these hazards, avoid overloading the machine during operation and make sure it is connected to a power supply circuit that meets the specified circuit requirements.

## Circuit Information

A power supply circuit includes all electrical equipment between the breaker box or fuse panel in the building and the machine. The power supply circuit used for this machine must be sized to safely handle the full-load current drawn from the machine for an extended period of time. (If this machine is connected to a circuit protected by fuses, use a time delay fuse marked D.)

**Note:** *Circuit requirements in this manual apply to a dedicated circuit—where only one machine will be running on the circuit at a time. If machine will be connected to a shared circuit where multiple machines may be running at the same time, consult an electrician or qualified service personnel to ensure circuit is properly sized for safe operation.*



## Grounding Requirements

This machine **MUST** be grounded. In the event of certain malfunctions or breakdowns, grounding reduces the risk of electric shock by providing a path of least resistance for electric current.

Improper connection of the equipment-grounding wire can result in a risk of electric shock. The wire with green insulation (with or without yellow stripes) is the equipment-grounding wire. If repair or replacement of the power cord or plug is necessary, do not connect the equipment-grounding wire to a live (current carrying) terminal.

Check with a qualified electrician or service personnel if you do not understand these grounding requirements, or if you are in doubt about whether the tool is properly grounded. If you ever notice that a cord or plug is damaged or worn, disconnect it from power, and immediately replace it with a new one.

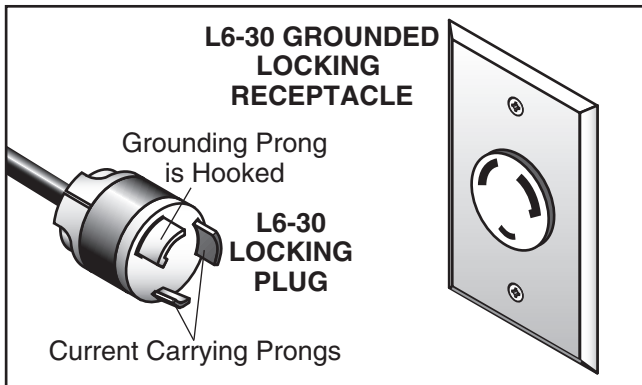


## G0623X Circuit Requirements

This machine is prewired to operate on a power supply circuit that has a verified ground and meets the following requirements:

**Nominal Voltage** .....208V, 220V, 230V, 240V  
**Cycle**.....60 Hz  
**Phase**..... Single-Phase  
**Circuit Rating**..... 30 Amps  
**Plug/Receptacle** .....L6-30

This machine is equipped with a power cord that has an equipment-grounding wire and a grounding plug. Only insert plug into a matching receptacle (outlet) that is properly installed and grounded in accordance with all local codes and ordinances. **DO NOT** modify the provided plug!



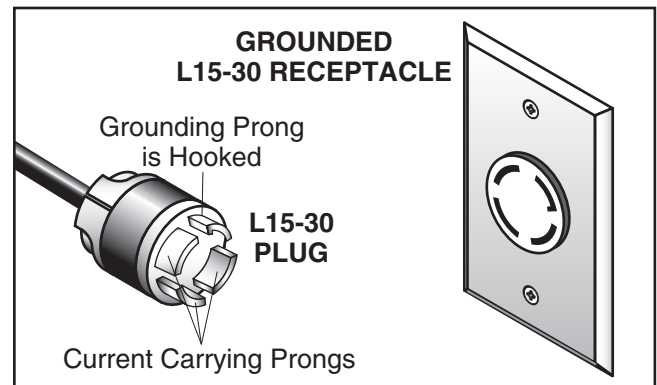
**Figure 1.** Typical L6-30 plug and receptacle.

## G0623X3 Circuit Requirements 220V

This machine is prewired to operate on a power supply circuit that has a verified ground and meets the following requirements:

**Nominal Voltage** .....208V, 220V, 230V, 240V  
**Cycle**.....60 Hz  
**Phase**..... 3-Phase  
**Power Supply Circuit** ..... 30 Amps  
**Plug/Receptacle** ..... L15-30  
**Cord**..... "S"-Type, 4-Wire, 10 AWG, 300 VAC

The power cord and plug used on this machine must have an equipment-grounding wire and grounding prong. The plug must only be inserted into a matching receptacle (outlet) that is properly installed and grounded in accordance with all local codes and ordinances (see figure below).



**Figure 2.** Typical L15-30 plug and receptacle.

**⚠ CAUTION**

**No adapter should be used with plug. If plug does not fit available receptacle, or if machine must be reconnected for use on a different type of circuit, reconnection must be performed by an electrician or qualified service personnel, and it must comply with all local codes and ordinances.**

**⚠ CAUTION**

**No adapter should be used with plug. If plug does not fit available receptacle, or if machine must be reconnected for use on a different type of circuit, reconnection must be performed by an electrician or qualified service personnel, and it must comply with all local codes and ordinances.**



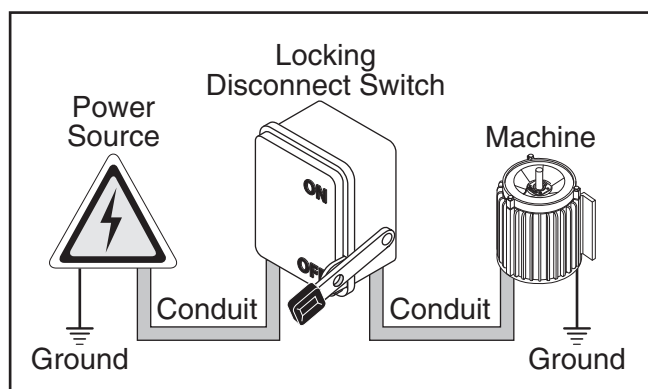


## G0623X3 Circuit Requirements 440V

This machine can be converted to operate on a power supply circuit that has a verified ground and meets the requirements listed below. (Refer to **Voltage Conversion** instructions for details.)

**Nominal Voltage** ..... 440V, 480V  
**Cycle** ..... 60 Hz  
**Phase** ..... 3-Phase  
**Power Supply Circuit** ..... 15 Amps  
**Connection Type** ..... Permanent (Hardwire)

A permanently connected (hardwired) power supply is typically installed with wires running through mounted and secured conduit. A disconnecting means, such as a locking switch (see following figure), must be provided to allow the machine to be disconnected (isolated) from the power supply when required. This installation must be performed by an electrician in accordance with all applicable electrical codes and ordinances.



**Figure 3.** Typical setup of a permanently connected (hardwired) machine.

In the event of a malfunction or breakdown, grounding provides a path of least resistance for electrical current to reduce the risk of electric shock. A permanently connected machine must be connected to a grounded metal permanent wiring system; or to a system having an equipment-grounding conductor. All grounds must be verified and rated for the electrical requirements of the machine. Improper grounding can increase the risk of electric shock!

## Extension Cords

We do not recommend using an extension cord with this machine. If you must use an extension cord, only use it if absolutely necessary and only on a temporary basis.

Extension cords cause voltage drop, which can damage electrical components and shorten motor life. Voltage drop increases as the extension cord size gets longer and the gauge size gets smaller (higher gauge numbers indicate smaller sizes).

Any extension cord used with this machine must be in good condition and contain a ground wire and matching plug/receptacle. Additionally, it must meet the following size requirements:

**G0623X** ..... 3 Wire, 10 AWG, 50 ft. or less  
**G0623X3 (220V)** 4 Wire, 10 AWG, 50 ft. or less  
**G0623X3 (440V)** .....N/A (Hardwired)



# G0623X3 440V Voltage Conversion

---

The Model G0623X3 is prewired for 220V 3-phase operation, but can be rewired for 440V operation.

To complete this conversion procedure, you must buy a 440V magnetic switch and rewire the motor for 440V operation. The 440V magnetic switch, Part P0623X30346A, can be purchased from Grizzly by calling 1-800-523-4777.

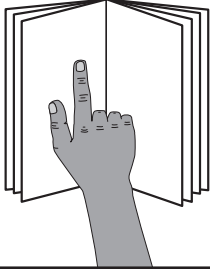
This rewiring job must be inspected by a qualified electrician before the saw is connected to the power source. Also, the junction box on the motor can be accessed easier for rewiring if the blade is moved to 0° (90° to table) before beginning.

## To rewire the machine for 440V operation:

1. DISCONNECT MACHINE FROM POWER!
2. Remove cover of magnetic switch.
3. Disconnect all wires from incoming power cords.
4. Remove magnetic switch and install new magnetic switch in same manner as old switch was installed. Refer to wiring diagram on **Page 80** if you need help remembering where wires are attached.
5. Remove cabinet cover from back of machine.
6. Rewire motor to 440V as shown in diagram on **Page 80**.
7. Replace junction box cover, cabinet door cover, and magnetic switch cover.



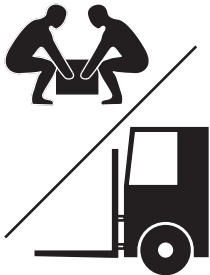
# SECTION 3: SETUP



**!WARNING**  
This machine presents serious injury hazards to untrained users. Read through this entire manual to become familiar with the controls and operations before starting the machine!



**!WARNING**  
Wear safety glasses during the entire setup process!



**!WARNING**  
**HEAVY LIFT!**  
Straining or crushing injury may occur from improperly lifting machine or some of its parts. To reduce this risk, get help from other people and use a forklift (or other lifting equipment) rated for weight of this machine.

## Needed for Setup

The following are needed to complete the setup process, but are not included with your machine.

Items Needed	Qty
• Additional People .....	2
• Safety Glasses (for each person) .....	1
• Heavy Leather Gloves.....	1 Pair
• Forklift (Rated for at least 800 lbs.).....	1
• Lifting Straps .....	2
• Cleaner/Degreaser ( <b>Page 22</b> )....	As Needed
• Disposable Shop Rags.....	As Needed
• Disposable Gloves .....	As Needed
• Main Saw Blade ( <b>Page 41</b> ) .....	1
• Prybar .....	1
• Straightedge 4' .....	1
• Level.....	1
• Phillips Screwdriver #2.....	1
• Open-End Wrenches 8, 10, 13mm .....	1 Ea.
• Hex Wrenches 3, 4, 5, 6, 8mm .....	1 Ea.
• Dust Collection System .....	1
• Dust Hose 4" .....	1
• Hose Clamps 4" .....	2
• Branch Line 4".....	As Needed
• Y-Fitting 2½" x 4" x 4" .....	As Needed
• NEMA L15-30 Plug (G0623X3)..	As Needed

## Unpacking

This machine was carefully packaged for safe transport. When unpacking, separate all enclosed items from packaging materials and inspect them for shipping damage. ***If items are damaged, please call us immediately at (570) 546-9663.***

**IMPORTANT:** Save all packaging materials until you are completely satisfied with the machine and have resolved any issues between Grizzly or the shipping agent. ***You MUST have the original packaging to file a freight claim. It is also extremely helpful if you need to return your machine later.***



# Inventory

The following is a list of items shipped with your machine. Before beginning setup, lay these items out and inventory them.

If any non-proprietary parts are missing (e.g. a nut or a washer), we will gladly replace them; or for the sake of expediency, replacements can be obtained at your local hardware store.

## NOTICE

If you cannot find an item on this list, carefully check around/inside the machine and packaging materials. Often, these items get lost in packaging materials while unpacking or they are pre-installed at the factory.

Crate Inventory (Figure 4)	Qty
A. Table Saw Body .....	1

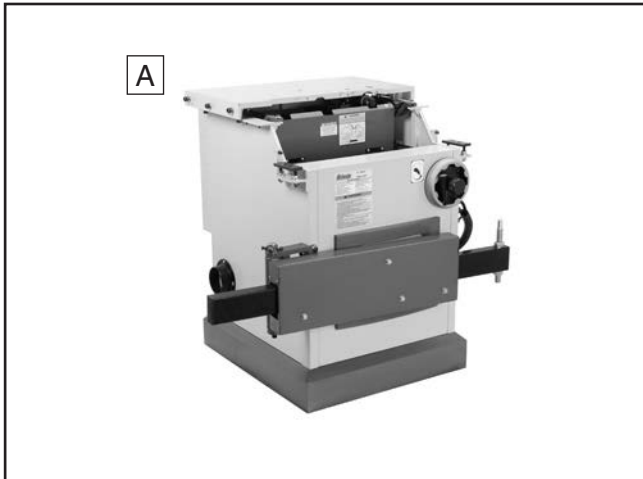


Figure 4. Table saw.

Inventory Items (Figure 5)	Qty
B. Large Extension Table .....	1
C. Small Extension Table.....	1
D. Hose Support .....	1

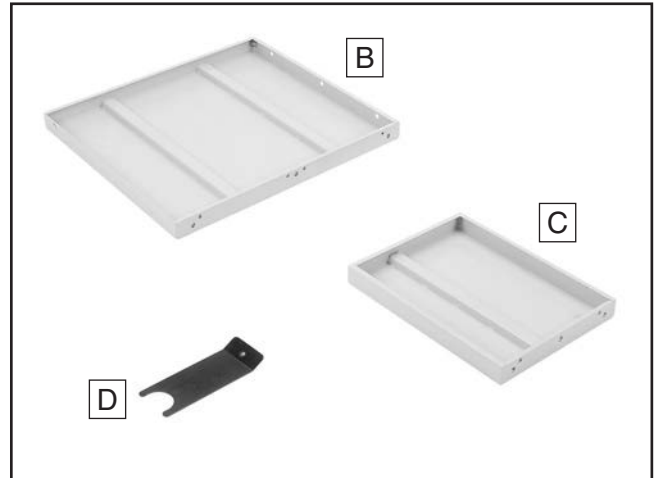


Figure 5. Extension table items.

Inventory Items (Figure 6)	Qty
E. Crosscut Fence .....	1
F. Support Bar .....	1
G. Crosscut Table .....	1
H. Crosscut Table Support Leg.....	1
I. Flip Stops .....	2
J. Lock Lever M12-1.75 x 55.....	1
K. Flat Washer 12mm .....	1
L. T-Nut M12-1.75.....	1

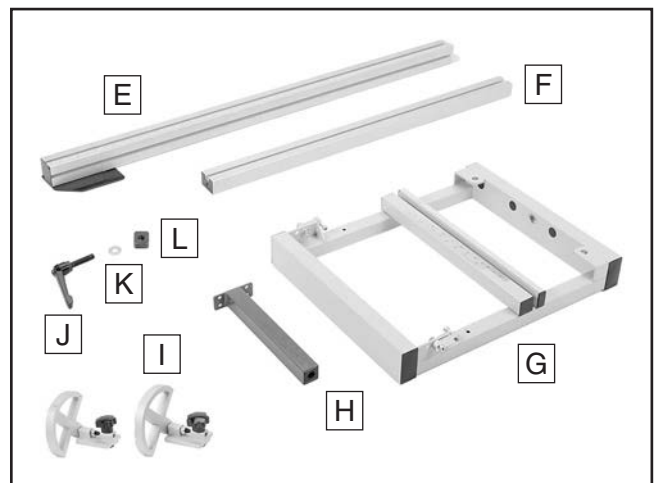
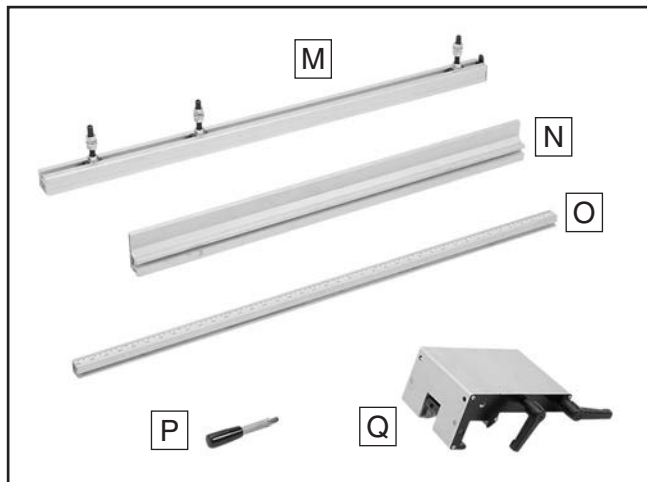


Figure 6. Crosscut table items.

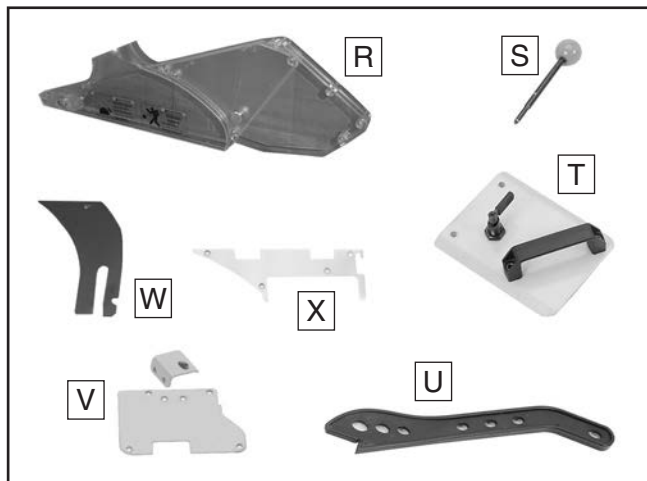


Inventory Items (Figure 7)	Qty
M. Rip Fence Rail.....	1
N. Rip Fence .....	1
O. Rip Fence Scale.....	1
P. Rip Fence Lever w/Hex Nut M8-1.25 .....	1
Q. Rip Fence Base.....	1



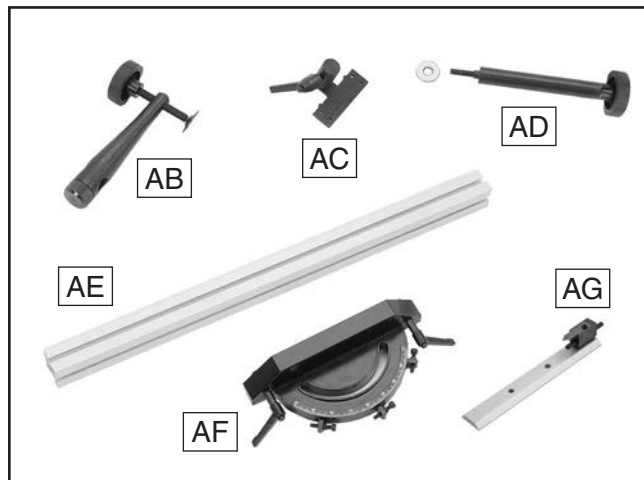
**Figure 7.** Rip fence items.

Inventory Items (Figure 8)	Qty
R. Blade Guard w/Cap Screw & Lock Nut.....	1
S. Arbor Lock Tool .....	1
T. Sliding Table Handle w/Lock .....	1
U. Push Stick .....	1
V. End Cover w/Bracket.....	1
W. Splitter/Riving Knife .....	1
X. Fixed Table End Cover .....	1
Y. Combo Wrench 17mm (Not Shown).....	1
Z. Closed-End Wrench 19/22mm (Not Shown) .	1
AA. Arbor Wrench (Not Shown) .....	1



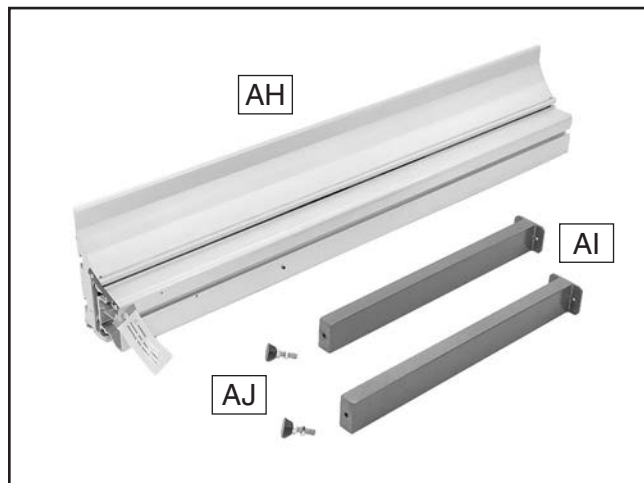
**Figure 8.** Miscellaneous components.

Inventory Items (Figure 9)	Qty
AB. Miter Clamp .....	1
AC. Miter Flip Stop .....	1
AD. Miter Handle w/Fender Washer 10mm.....	1
AE. Miter Gauge Fence.....	1
AF. Miter Gauge Body .....	1
AG. Miter Guide Bar .....	1



**Figure 9.** Miter gauge items.

Inventory Items (Figure 10)	Qty
AH. Sliding Table .....	1
AI. Sliding Table Support Legs .....	2
AJ. Feet M12-1.75 x 75 w/Nuts .....	2

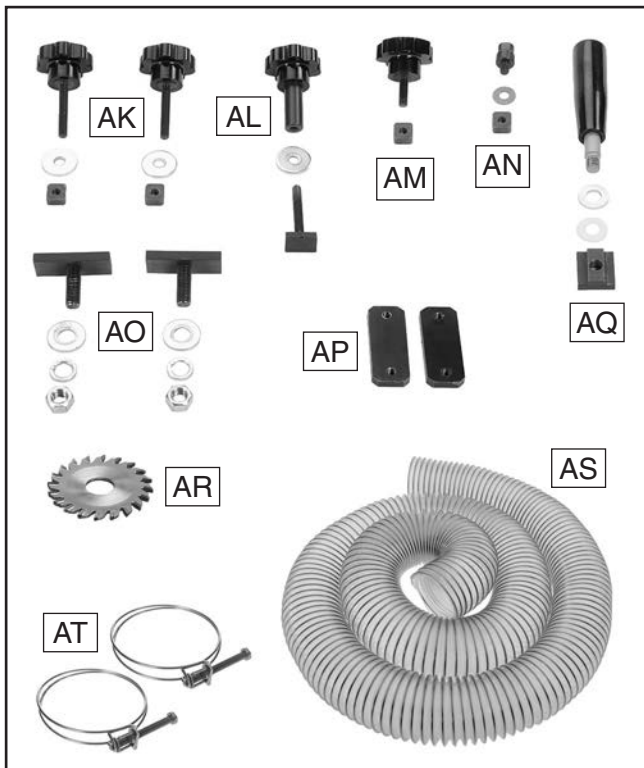


**Figure 10.** Sliding table items.



<b>Inventory Items (Figure 11)</b>	<b>Qty</b>
<b>AK.</b> Crosscut Brace Knobs M8-1.25 x 50 .....	2
—Flat Washers 8mm .....	2
—Square Nuts M8-1.25.....	2
<b>AL.</b> Crosscut Fence Knob M8-1.25.....	1
—Flat Washer 8mm .....	1
—Crosscut Fence T-Bolt M8-1.25 x 60.....	1
<b>AM.</b> Crosscut Fence Lock Knob M8-1.25 x 25..	1
—Square Nut M8-1.25.....	1
<b>AN.</b> Pivot Stud .....	1
—Special Washer 8 x 20mm .....	1
—Square Nut M8-1.25.....	1
<b>AO.</b> Push Handle M12-1.75 x 14 .....	1
—Flat Washer 12mm.....	1
—Plastic Washer 12mm.....	1
—Push Handle T-Nut M12-1.75 .....	1
<b>AP.</b> Support Leg T-Slot Plates .....	2
<b>AQ.</b> Sliding Table T-Studs M12-1.75 x 35 .....	2
—Flat Washers 12mm .....	2
—Lock Washers 12mm.....	2
—Hex Nuts M12-1.75.....	2
<b>AR.</b> Scoring Blade.....	1
<b>AS.</b> Dust Hose 2½" .....	1
<b>AT.</b> Hose Clamps 2½" .....	2

<b>Other Hardware (Not Shown)</b>	<b>Qty</b>
Cap Screws M10-1.5 x 25 (Extension Tables)..	5
Flat Washers 10mm (Extension Tables).....	5
Lock Washers 10mm (Extension Tables) .....	5
Set Screws M8-1.25 x 25 (Extension Tables)...	5
Hex Nuts M8-1.25 (Extension Tables) .....	5
Hex Bolts M6-1 x 16 (Fence Scale) .....	2
Hex Bolt M6-1 x 25 (Fence Scale).....	1
Flat Washers 6mm (Fence Scale).....	3
Lock Washers 6mm (Fence Scale) .....	3
Hex Nuts M6-1 (Fence Scale).....	3
Cap Screws M6-1 x 16 (CT Support Leg).....	4
Lock Washers 6mm (CT Support Leg) .....	4
Flat Washers 6mm (CT Support Leg) .....	4
Button Head Screws M5-.8 x 25 (Switch) .....	2
Flange Nuts M5-.8 (Switch).....	2
Cap Screws M8-1.25 x 20 (ST Leg Plates) .....	4
Lock Washers 8mm (ST Leg Plates) .....	4
Lock Nut M10-1.5 (Hose Support) .....	1
Lock Washer 10mm (Hose Support).....	1
Cap Screw M10-1.5 x 25 (Hose Support) .....	1
Flat Washers 10mm (Hose Support).....	2
Button Head Cap Screws M6-1 x 16	
(ST Handle) .....	2
Lock Washers 6mm (ST Handle) .....	2
Flat Washers 6mm (ST Handle).....	4
Hex Nuts M6-1 (ST Handle).....	2



**Figure 11.** Miscellaneous components.



# Hardware Recognition Chart

USE THIS CHART TO MATCH UP  
HARDWARE DURING THE INVENTORY  
AND ASSEMBLY PROCESS.

MEASURE BOLT DIAMETER BY PLACING INSIDE CIRCLE

#10

1/4"

5/16"

3/8"

7/16"

1/2"

4mm

5mm

6mm

8mm

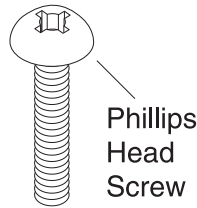
10mm

12mm

16mm



Hex  
Wrench



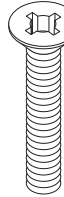
Phillips  
Head  
Screw



Lock  
Nut



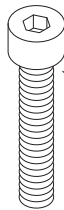
Wing  
Nut



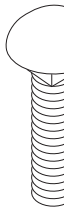
Flat  
Head  
Screw



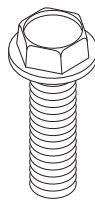
Flat  
Head  
Cap  
Screw



Cap  
Screw



Carriage  
Bolt



Flange  
Bolt



Button  
Head  
Screw



Tap  
Screw



External  
Retaining  
Ring



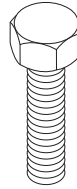
Internal  
Retaining  
Ring



E-Clip



Set  
Screw



Hex  
Bolt



Key



Flat Washer

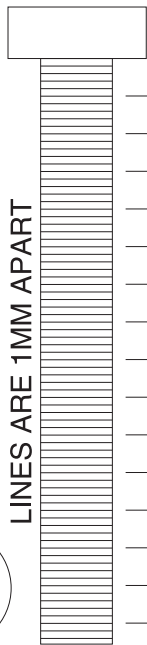


Lock  
Washer



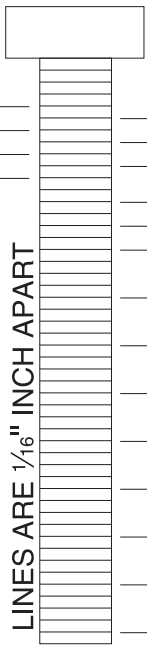
Hex  
Nut

LINES ARE 1MM APART



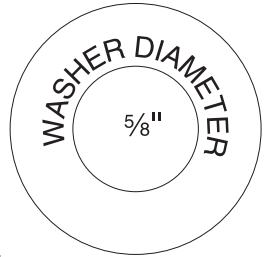
5mm  
10mm  
15mm  
20mm  
25mm  
30mm  
35mm  
40mm  
45mm  
50mm  
55mm  
60mm  
65mm  
70mm  
75mm

LINES ARE 1/16" INCH APART

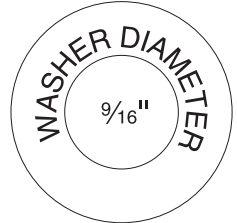


1/4"  
3/8"  
1/2"  
5/8"  
5/16"  
7/16"  
9/16"  
3/4"  
7/8"  
1"  
1 1/4"  
1 1/2"  
1 3/4"  
2  
2 1/4"  
2 1/2"  
2 3/4"  
3

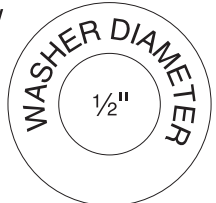
WASHERS ARE MEASURED BY THE INSIDE DIAMETER



WASHER DIAMETER  
5/8"



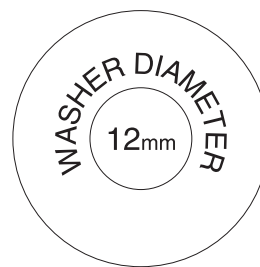
WASHER DIAMETER  
9/16"



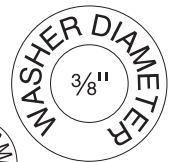
WASHER DIAMETER  
1/2"



WASHER DIAMETER  
7/16"



WASHER DIAMETER  
12mm



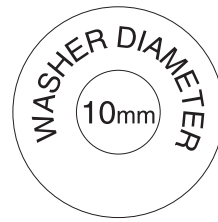
WASHER DIAMETER  
3/8"



4mm



WASHER DIAMETER  
5/16"



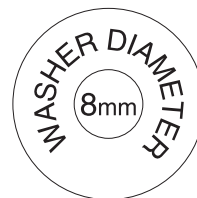
WASHER DIAMETER  
10mm



5mm



WASHER DIAMETER  
1/4"



WASHER DIAMETER  
8mm



6mm



#10



# Cleanup

The unpainted surfaces of your machine are coated with a heavy-duty rust preventative that prevents corrosion during shipment and storage. This rust preventative works extremely well, but it will take a little time to clean.

Be patient and do a thorough job cleaning your machine. The time you spend doing this now will give you a better appreciation for the proper care of your machine's unpainted surfaces.

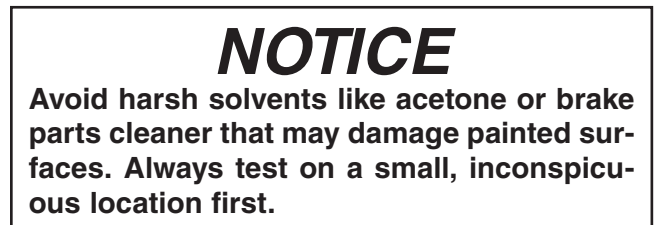
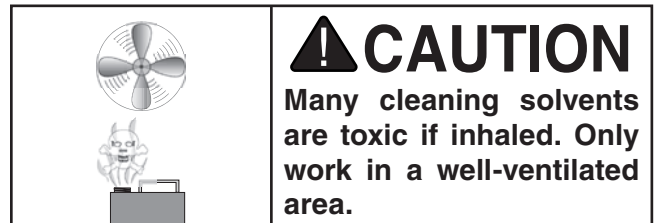
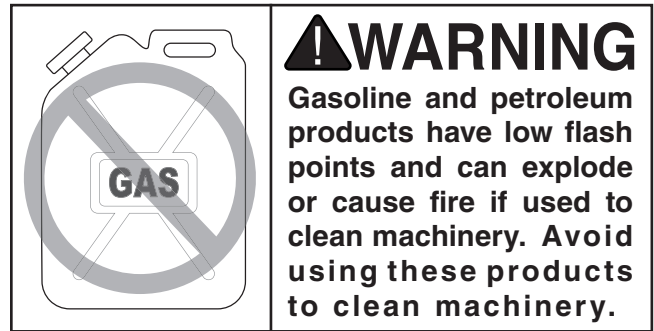
There are many ways to remove this rust preventative, but the following steps work well in a wide variety of situations. Always follow the manufacturer's instructions with any cleaning product you use and make sure you work in a well-ventilated area to minimize exposure to toxic fumes.

## Before cleaning, gather the following:

- Disposable rags
- Cleaner/degreaser (WD•40 works well)
- Safety glasses & disposable gloves
- Plastic paint scraper (optional)

## Basic steps for removing rust preventative:

1. Put on safety glasses.
2. Coat the rust preventative with a liberal amount of cleaner/degreaser, then let it soak for 5–10 minutes.
3. Wipe off the surfaces. If your cleaner/degreaser is effective, the rust preventative will wipe off easily. If you have a plastic paint scraper, scrape off as much as you can first, then wipe off the rest with the rag.
4. Repeat **Steps 2–3** as necessary until clean, then coat all unpainted surfaces with a quality metal protectant to prevent rust.



## T23692—Orange Power Degreaser

A great product for removing the waxy shipping grease from the **non-painted** parts of the machine during clean up.



Figure 12. T23692 Orange Power Degreaser.





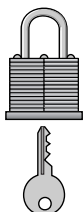
# Site Considerations

## Weight Load

Refer to the **Machine Data Sheet** for the weight of your machine. Make sure that the surface upon which the machine is placed will bear the weight of the machine, additional equipment that may be installed on the machine, and the heaviest workpiece that will be used. Additionally, consider the weight of the operator and any dynamic loading that may occur when operating the machine.

## Space Allocation

Consider the largest size of workpiece that will be processed through this machine and provide enough space around the machine for adequate operator material handling or the installation of auxiliary equipment. With permanent installations, leave enough space around the machine to open or remove doors/covers as required by the maintenance and service described in this manual. **See below for required space allocation.**

	<p><b>CAUTION</b></p> <p>Children or untrained people may be seriously injured by this machine. Only install in an access restricted location.</p>
---	--

## Physical Environment

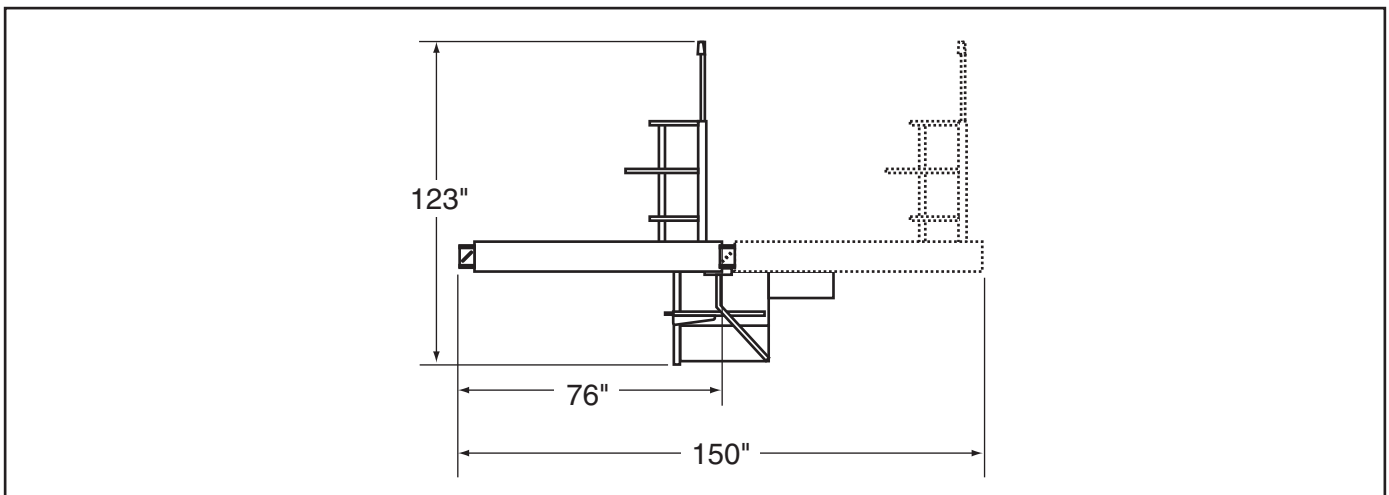
The physical environment where the machine is operated is important for safe operation and longevity of machine components. For best results, operate this machine in a dry environment that is free from excessive moisture, hazardous chemicals, airborne abrasives, or extreme conditions. Extreme conditions for this type of machinery are generally those where the ambient temperature range exceeds 41°–104°F; the relative humidity range exceeds 20%–95% (non-condensing); or the environment is subject to vibration, shocks, or bumps.

## Electrical Installation

Place this machine near an existing power source. Make sure all power cords are protected from traffic, material handling, moisture, chemicals, or other hazards. Make sure to leave enough space around machine to disconnect power supply or apply a lockout/tagout device, if required.

## Lighting

Lighting around the machine must be adequate enough that operations can be performed safely. Shadows, glare, or strobe effects that may distract or impede the operator must be eliminated.

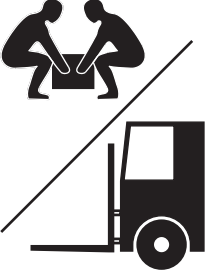


**Figure 13.** Minimum working clearances.



# Lifting & Placing

We strongly recommend using a forklift to move this saw. This will greatly reduce the risk of a lifting injury. If a forklift is *not* available, a *minimum* of four strong people are required to move the saw off the pallet. The saw can be "walked" off the pallet, then moved into place with a dolly or by sliding it.

	<p><b>⚠️ WARNING</b>  <b>HEAVY LIFT!</b>          Straining or crushing injury may occur from improperly lifting machine or some of its parts. To reduce this risk, get help from other people and use a forklift (or other lifting equipment) rated for weight of this machine.</p>
---	--

Items Needed	Qty
Additional People .....	2
Forklift (rated for 800 lbs.) .....	1
Lifting Straps .....	2

### To lift and place machine:

1. Feed lifting straps around lifting bolts on back of table and sliding table saw mounts on front of cabinet (see **Figure 14**). Attach the ends of lifting straps to forklift forks



**Figure 14.** Lifting the table saw cabinet.

## ⚠️ WARNING

**DO NOT** lift the table saw any higher than necessary to clear the floor. Serious personal injury and damage to the machine may occur if safe moving methods are not followed.

2. Lift table saw cabinet and move it to your predetermined location.
3. Remove red lifting bolts from back of table.
4. Place a level on cast-iron table to level table saw cabinet side to side and front to back. This will allow table to slide smoothly.

**Note:** There are three options for leveling the saw: 1) Place it on a mobile base (see **Page 66**) and use the mobile base controls to level it, 2) shim under the cabinet, and 3) thread bolts down into the nuts welded on the stand corners (see **Figure 15**).



**Figure 15.** Hex bolt in stand corners for leveling; the hex nut is used to secure bolt position.

## NOTICE

We strongly recommend securing your machine to the floor if it is hardwired to the power source. Consult with your electrician to ensure compliance with local codes.



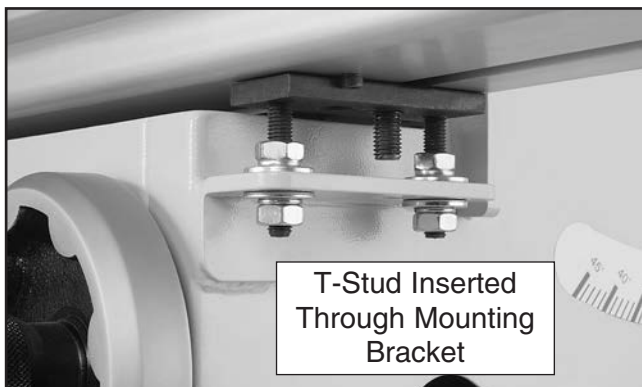
# Assembly

Before shipping, the sliding table was installed on the machine and calibrated to the main table and blade. When the sliding table was removed for shipping, the lock nuts on the sliding table mounting brackets were carefully left in position to make re-installation easier. As such, be careful not to move any pre-installed nuts when installing the sliding table.

The sliding table and extension tables are heavy so you must get help lifting and holding them during the installation process. We recommend using a forklift or four strong helpers to lift the sliding table during installation.

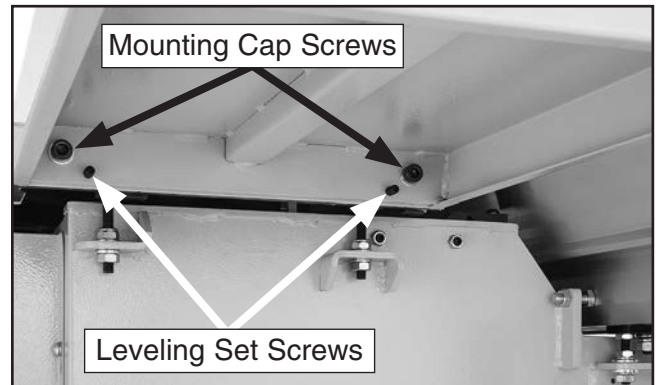
## To assemble the sliding table saw:

1. Place sliding table on cabinet.
2. On each side of sliding table, slide a T-stud down the center bottom T-slot until it is next to mounting bracket.
3. Lift one side of sliding table, position T-stud over hole in mounting bracket, then lower sliding table so T-stud fits through hole, as shown in **Figure 16**. Repeat on other side.



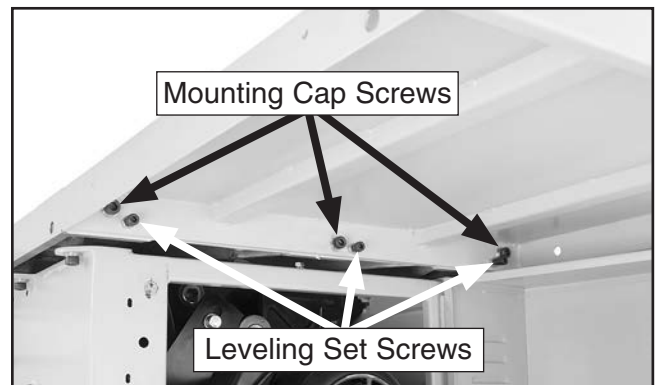
**Figure 16.** T-stud inserted in mounting bracket.

4. Put 12mm flat washer, lock washer and hex nut onto bottom of each T-stud and tighten hex nut to secure sliding table in place.
5. Install small extension table with two M10-1.5 x 25 cap screws, flat washers and lock washers (see **Figure 17**).
6. Thread one M8-1.25 hex nut halfway onto each M8-1.25 x 25 set screw, then thread two set screws where shown in **Figure 17**, to act as leveling set screws in a later step.



**Figure 17.** Small extension table installed.

7. Install large extension table with three M10-1.5 x 25 cap screws, flat washers, and lock washers (see **Figure 18**).
8. Thread three M8-1.25 x 25 set screws with hex nuts where shown in **Figure 18**, to act as leveling set screws in a later step.



**Figure 18.** Large extension table installed.



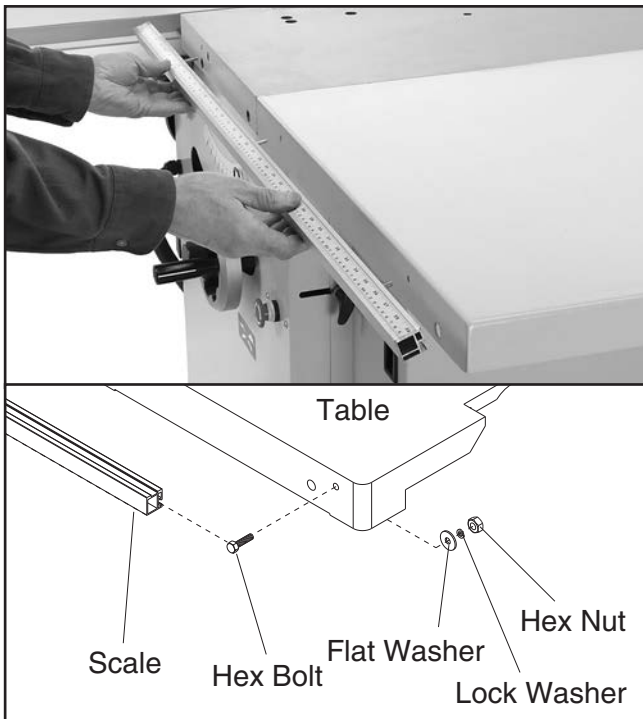
- Level top of extension tables even with top of cast-iron table.

Using straightedge as a guide (**Figure 19**), adjust leveling set screws to align top of extension tables with top of cast-iron table. Tighten hex nuts on leveling set screws against extension table to lock set screws when tables are aligned.



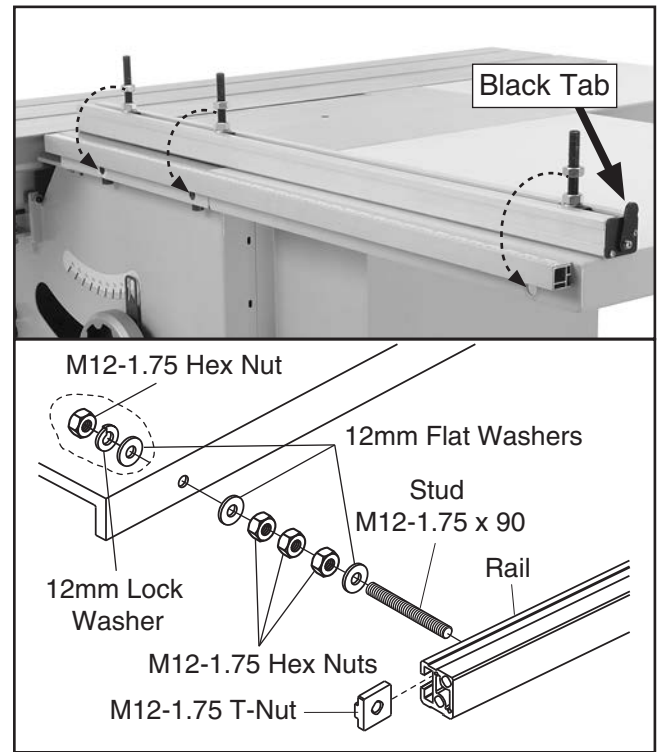
**Figure 19.** Extension wings mounted and even with cast-iron table.

- Mount rip fence scale to large extension table and cast-iron table (**Figure 20**) using three M6-1 hex nuts, lock washers, flat washers, two M6-1 x 16 hex bolts, and one M6-1 x 25 hex bolt. (The longer hex bolt is used in the cast-iron table.) Secure scale height so it is even with table tops.



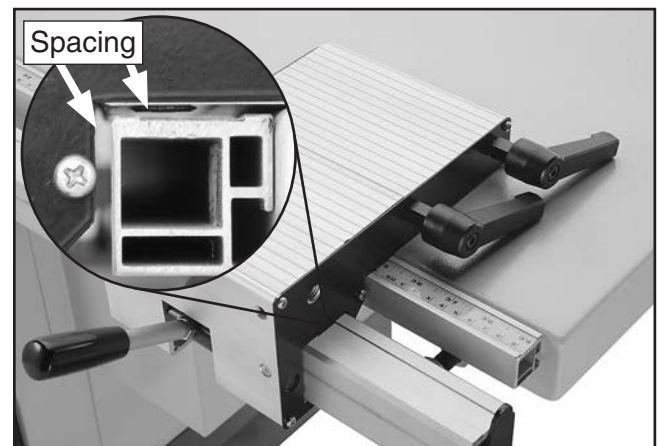
**Figure 20.** Mounting rip fence scale.

- Mount rip fence rail as shown in **Figure 21**. Make sure black tab is toward back end of saw. Adjust hex nuts so gap between rail and tables is even, but leave rail slightly loose for now.



**Figure 21.** Rip fence rail mounting.

- Slide rip fence base on rail, and check spacing between rip fence base and scale bar (see **Figure 22**). There should be a minimum of 1/8" between scale bar and fence base. Adjust mounting position of rip fence rail to create this space evenly along length of scale bar, then tighten rail mounting nuts.

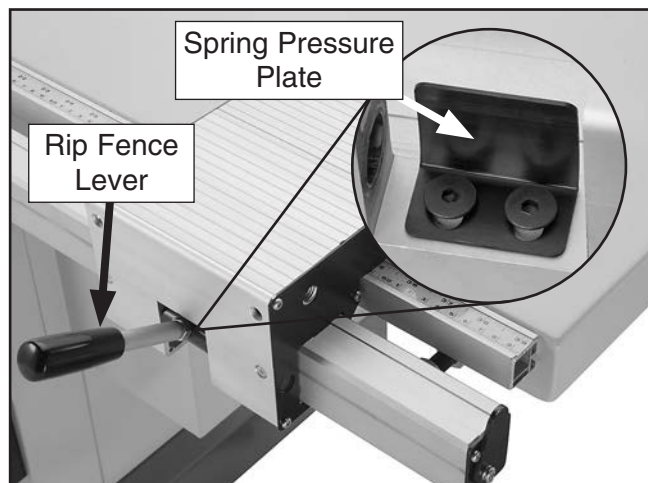


**Figure 22.** Fence base installed; spacing between fence base and scale bar.



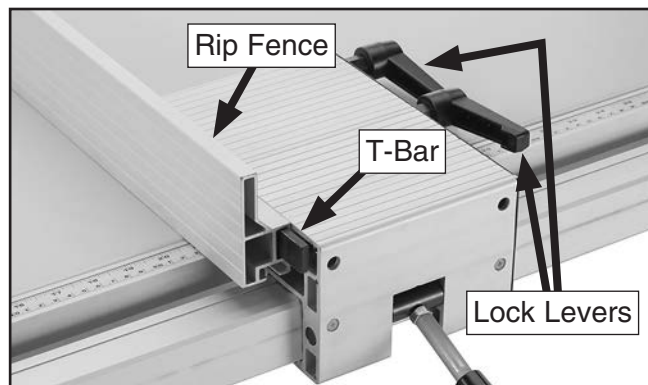
**Note:** The fence should slide smoothly on the rail; if it doesn't, remove the fence base and adjust the spring pressure plate mounting position on the fence base (see **Figure 23**).

13. Thread rip fence lever into fence base (**Figure 23**), tighten hex nut against rip fence base to keep lever in place.



**Figure 23.** Location of spring pressure plate for fence slide adjustments.

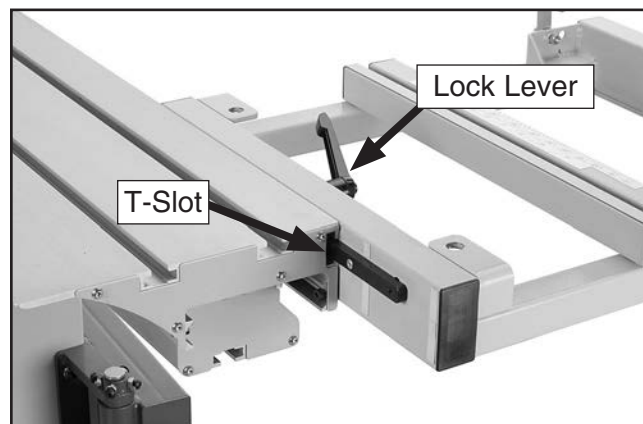
14. Slide rip fence on fence base T-bar as shown in **Figure 24**. Use two lock levers on opposite side of fence base to secure fence in position.



**Figure 24.** Rip fence installed on fence base.

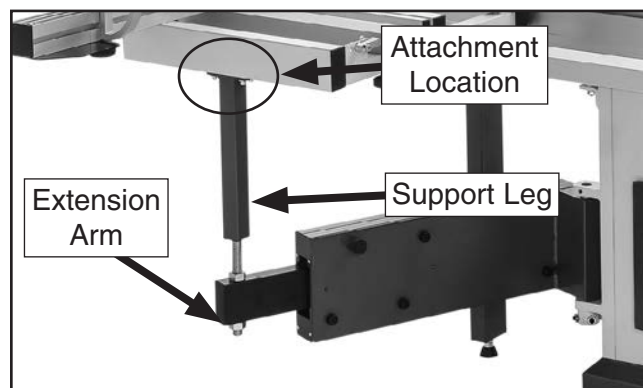
15. Place 12mm flat washer on crosscut table lock lever, then insert it through crosscut fence and thread M12-1.75 T-nut onto end approximately two turns.

16. Align T-slot bars and T-nuts on crosscut table with T-slot in face of sliding table, then slide crosscut table into position on sliding table and tighten crosscut table lock lever (see **Figure 25**).



**Figure 25.** Crosscut table installation.

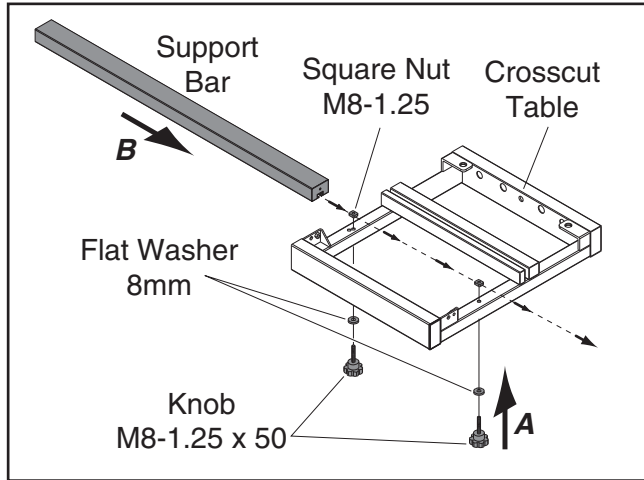
17. Place crosscut table support leg on extension arm, and attach it to crosscut table with four M6-1 x 16 cap screws, 6mm lock washers, and 6mm flat washers (see **Figure 26**).



**Figure 26.** Support leg installed.

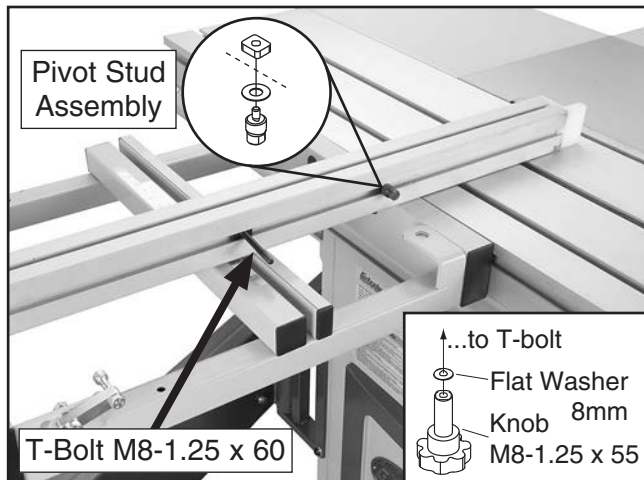


18. Insert two crosscut brace knobs with 8mm flat washers through crosscut table, then thread square nuts onto ends of knob threads (**Figure 27, A**). Slide T-slot in support bar over both T-nuts, and tighten knobs (**Figure 27, B**).



**Figure 27.** Installing support bar on crosscut table.

19. Slide pivot stud assembly and M8-1.25 x 60 T-bolt into crosscut fence T-slot, as shown in **Figure 28**.
20. Align T-bolt and pivot stud with crosscut table insertion points (see **Figure 28**), and install fence on table.

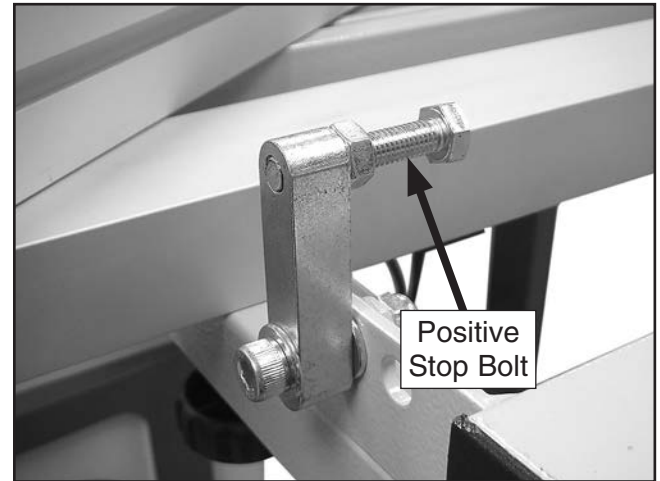


**Figure 28.** Pivot stud and T-bolt installed in crosscut fence.

21. Thread M8-1.25 knob with an 8mm flat washer onto bottom of T-bolt from underside of table.

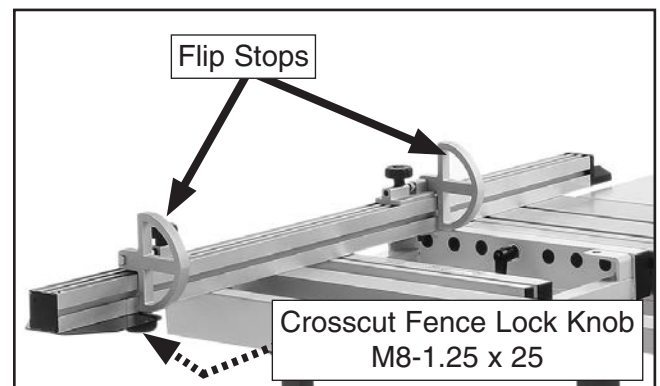
22. Hold crosscut fence against positive stop bolt, shown in **Figure 29**, then tighten knob underneath crosscut table to lock crosscut fence in position.

**Note:** This positive stop bolt can be fine-tuned later to ensure that the crosscut fence is square to the blade.



**Figure 29.** Use positive stop bolt to position the crosscut fence.

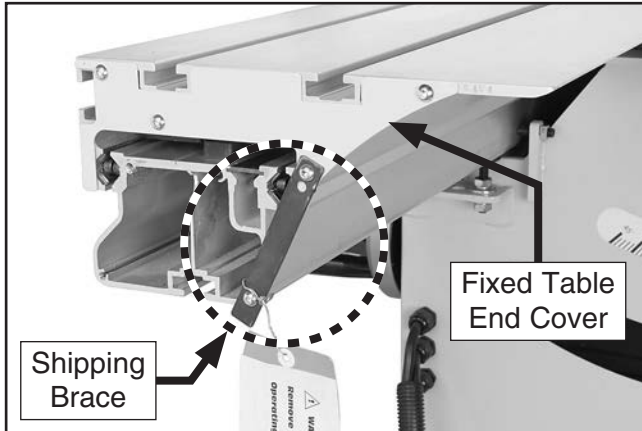
23. Install flip stops in T-slot on crosscut fence, as shown in **Figure 30**, and use crosscut fence lock knob to secure extendable end of fence in position.



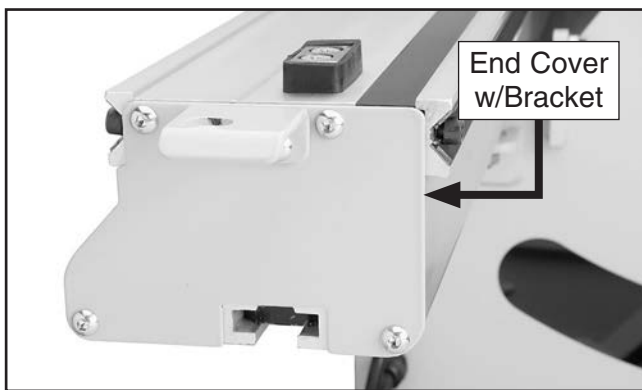
**Figure 30.** Flip stops installed on crosscut fence.



24. Remove shipping brace from sliding table (see **Figure 31**), and install fixed table end cover over fixed part of sliding table end, then install end cover w/bracket over sliding table end using premounted hardware (see **Figures 31–32**).

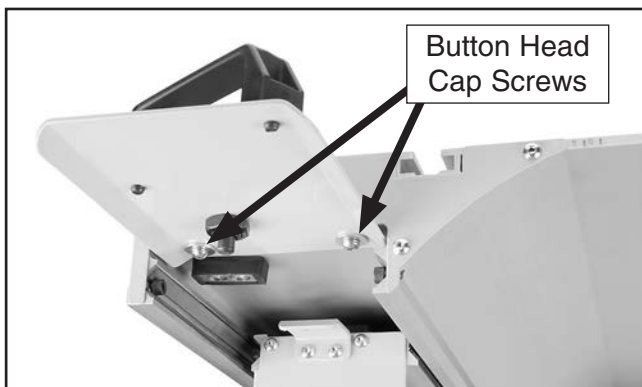


**Figure 31.** Fixed table components location.



**Figure 32.** Sliding table end cover installed.

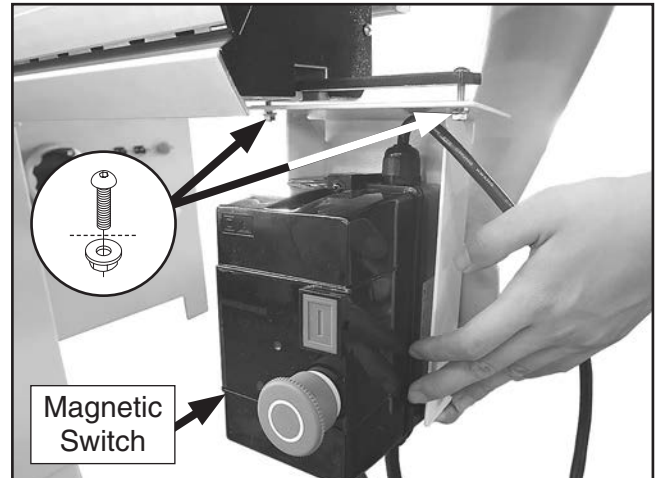
25. Attach sliding table handle, as shown in **Figure 33**, with two button head screws and flat washers, using premounted hardware.



**Figure 33.** Sliding table handle attached to end of sliding table.

26. Verify that two M5-.8 x 25 button head screws are threaded tightly into magnetic switch mounting bracket. Loosen two attached M5-.8 flange nuts for clearance if needed, then slide mounting bracket and switch into sliding table base T-slot.

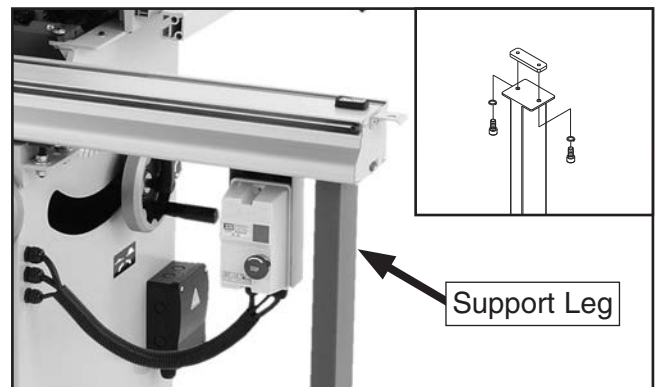
27. Adjust switch location, then tighten M5-.8 flange nuts to secure (see **Figure 34**).



**Figure 34.** Magnetic switch attached with flange nuts adjusts for location.

28. Thread feet fully into bottom of support legs. DO NOT remove hex nuts pre-installed on bottom of feet. They will be used to secure feet after legs are installed.

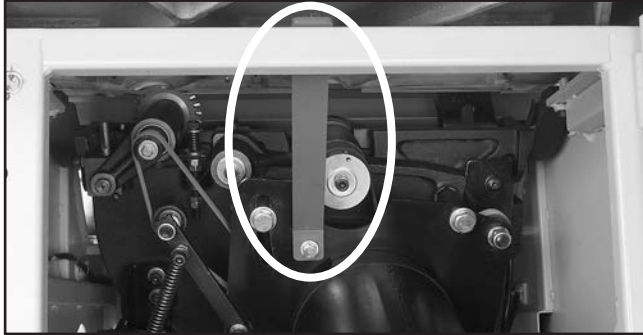
29. Thread two M8-1.25 x 20 cap screws and 8mm lock washers through each support leg and part way into T-slot plates for legs, slide T-slot plates into both ends of sliding table base, and tighten cap screws (see **Figure 35**).



**Figure 35.** Support leg installed (1 of 2 shown).



- 30. Adjust feet downward so they press against floor, then tighten hex nuts up against support leg so feet are locked in place.
- 31. Open cabinet door and remove motor shipping brace shown in **Figure 36**.



**Figure 36.** Motor shipping brace.

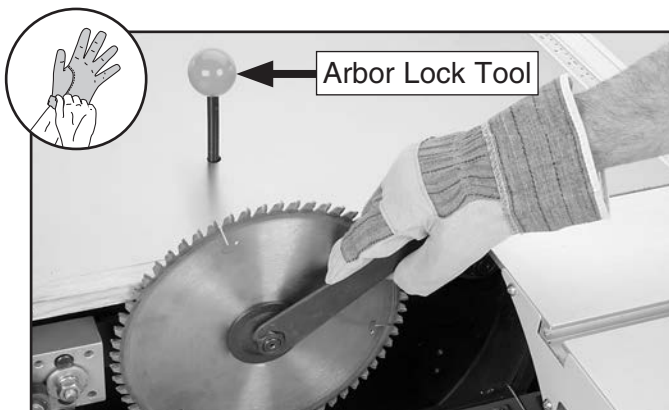
- 32. Tilt blade assembly to 0°, then slide sliding table forward all the way until you can open lower blade guard cover and access blade arbors.

## **NOTICE**

**The Model G0623X and G0623X3 do not ship with a 10" main blade. See *Blade Requirements/Blade Selection* beginning on Page 41 when purchasing main blade.**

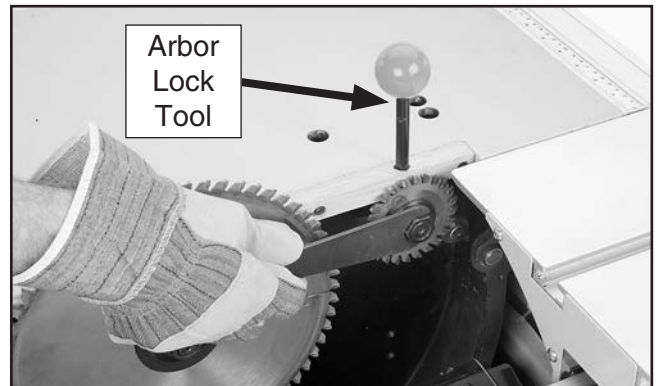
- 33. Insert arbor lock tool into hole shown in **Figure 37**, rotate arbor until arbor lock tool seats, then install main blade according to **Step 7 of Changing Main Blade on Page 43**.

**IMPORTANT:** There MUST be an arbor flange on both sides of blade.



**Figure 37.** Installing main blade.

- 34. Insert arbor lock tool into hole shown in **Figure 38**, rotate arbor until arbor lock tool seats, then install scoring blade, using arbor wrench. There MUST be an arbor flange on both sides of blade.



**Figure 38.** Installing scoring blade.

- 35. Install splitter/riving knife (see **Figure 39**). DO NOT tighten mounting bolt at this time.



**Figure 39.** Installing splitter/riving knife.

- 36. Adjust splitter/riving knife approximately 1/8" away from main blade, using a 1/8" or 3mm hex wrench as guide (see **Figure 40**).



**Figure 40.** Adjusting the riving knife spacing.

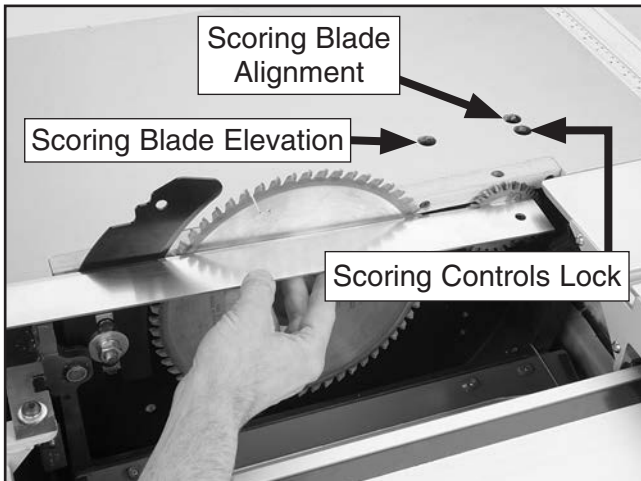




**37.** Use straightedge to make sure splitter/riving knife and scoring blade are aligned with main blade. Alignment should be with blade bodies, not the carbide teeth.

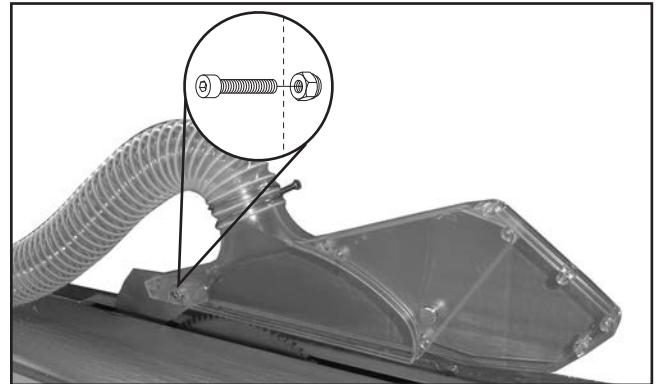
—Splitter/riving knife position can be changed by adjusting set screws at splitter/riving knife mounting block. Refer to **Page 76** for more details.

—Scoring blade alignment can be changed by adjusting set screws accessible through table top (see **Figure 41**).



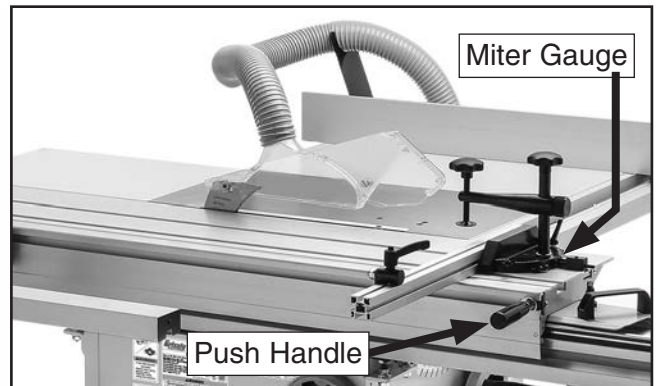
**Figure 41.** Access holes for scoring blade adjustment controls.

**38.** Install blade guard on splitter/riving knife, as shown in **Figure 42**, with M10-1.5 x 25 cap screw and M10-1.5 lock nut shipped in blade guard assembly. (Blade guard/dust hood **MUST** be installed.)



**Figure 42.** Blade guard installed.

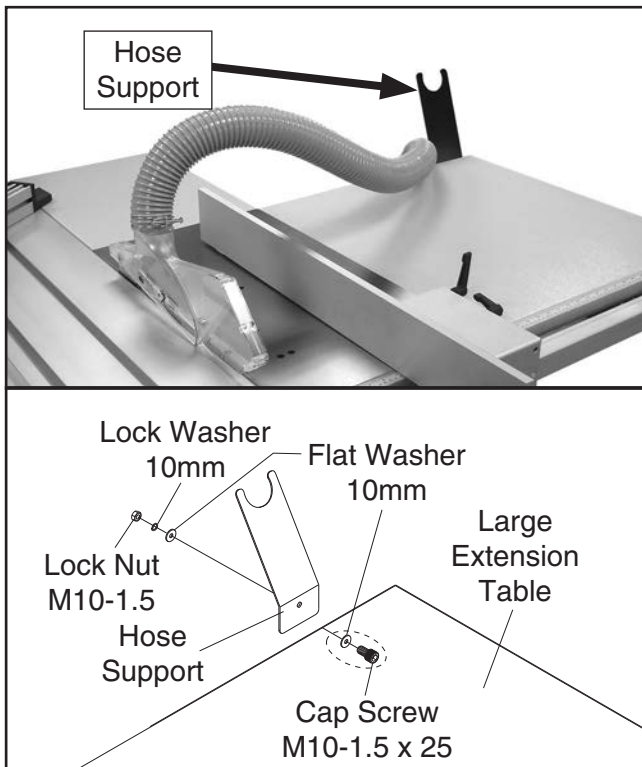
**39.** Assemble miter gauge and push handle as shown in **Figure 43**.



**Figure 43.** Miter gauge and push handle installed.



40. Attach hose support to large extension table as shown in **Figure 44**.



**Figure 44.** Attaching hose support to large extension table..

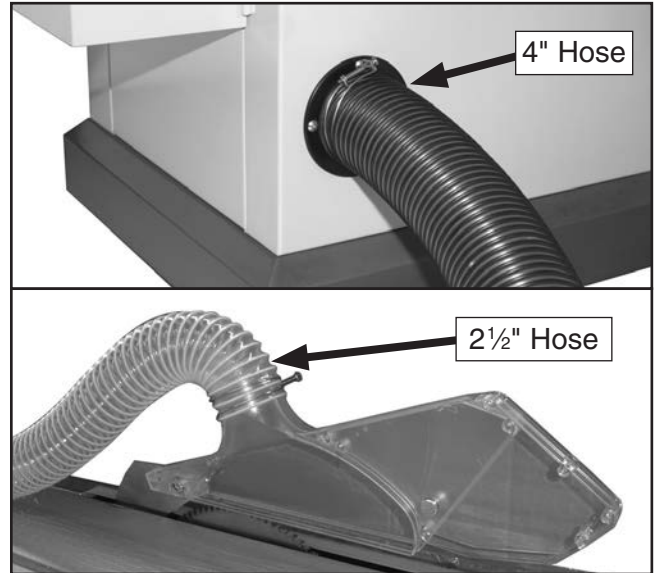
## **! CAUTION**

**DO NOT** operate this saw without an adequate dust collection system. This saw creates substantial amounts of wood dust while operating. Failure to use a dust collection system can result in short and long-term respiratory illness.

**Minimum CFM at 4" Dust Port: 400 CFM**  
**Minimum CFM at 2½" Dust Port: 150 CFM**

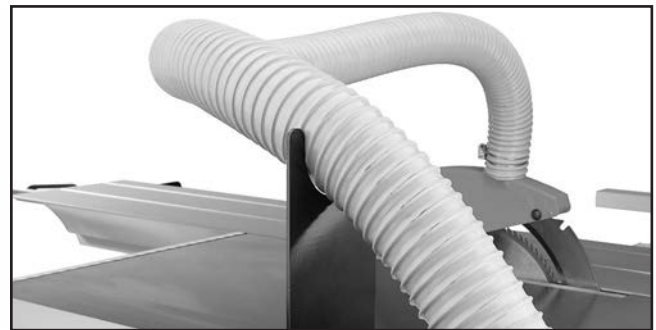
*Do not confuse this CFM recommendation with the rating of the dust collector. To determine the CFM at the dust port, you must consider these variables: (1) CFM rating of the dust collector, (2) hose type and length between the dust collector and the machine, (3) number of branches or wyes, and (4) amount of other open lines throughout the system. Explaining how to calculate these variables is beyond the scope of this manual. Consult an expert or purchase a good dust collection "how-to" book.*

41. Secure 4" dust hose to dust port located under saw table and 2½" dust hose to blade guard (see **Figure 45**).



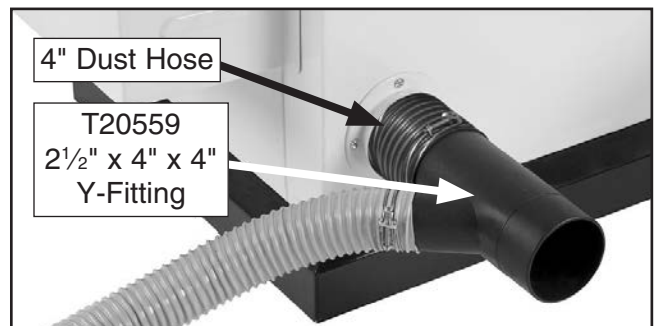
**Figure 45.** Dust hoses attached.

42. Run 2½" hose over hose support, as shown in **Figure 46**.



**Figure 46.** Dust hose placement on hose support.

**Tip:** Connect saw to a single dust collection branch line, using optional accessory shown in **Figure 47**.



**Figure 47.** Optional accessories for consolidating dust lines.



# Power Connection

Before the machine can be connected to the power source, an electrical circuit must be made available that meets the minimum specifications given in Circuit Requirements on **Page 14**. If a power circuit has not been prepared for the machine, do that now. To ensure a safe and code-compliant setup, we strongly recommend that all electrical work be done by an electrician or qualified service personnel.

## G0623X/G0623X3 230V/220V Power Connection

Insert the plug into a matching NEMA receptacle, (see **Figure 1** for G0623X and **Figure 2** for G0623X3 on **Page 14**).

## G0623X3 440V Power Connection

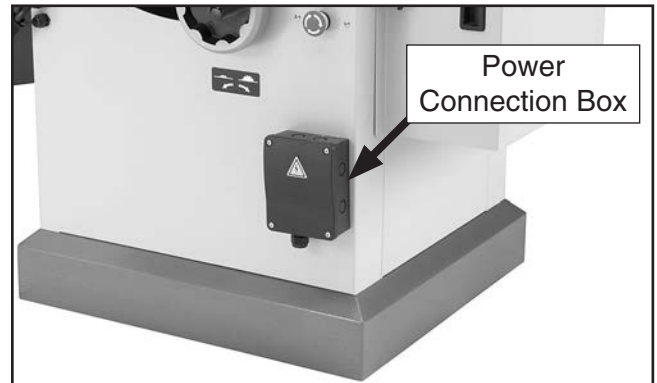
Hardwire setups require power supply lines to be enclosed inside conduit, which is securely mounted and constructed in adherence to applicable electrical codes.

A hardwire setup for this machine must be equipped with a locking disconnect switch as a means to disconnect the power during adjustments or maintenance, which is a typical requirement for lock-out/tag-out safety programs (commonly required by OSHA).

**Figure 3** on **Page 15** shows a simple diagram of a hardwire setup with a locking disconnect switch between the power source and the machine. Due to the complexity required for planning, bending, and installing the conduit necessary for a hardwire setup, this type of setup should only be performed by an experienced electrician.

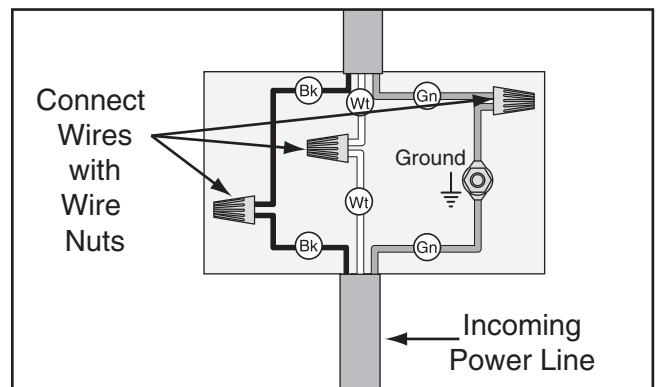
To connect the Model G0623X3 to power:

1. Open power connection box shown in **Figure 48**.



**Figure 48.** Power connection box.

2. Loosen strain relief on bottom of connection box, then insert incoming power wires into connection box.
3. Connect incoming power wires and ground wire to wires in connection box using wire nuts, (see **Figure 49**), then wrap each wire nut and their respective wires with electrical tape to secure them together.

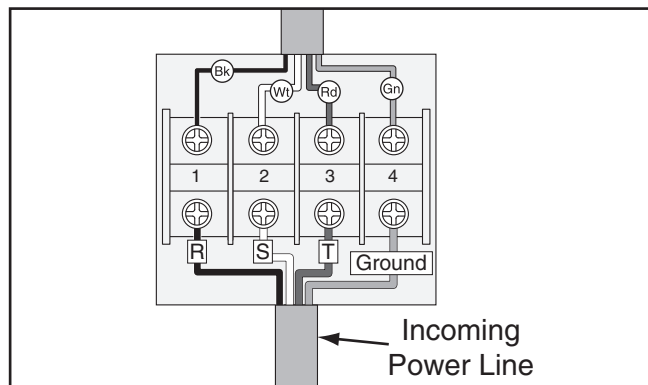


**Figure 49.** Model G0623X incoming power wires connected.



Connect incoming power wires to terminals shown in **Figure 50**.

**Note:** If using a phase converter, connect the manufactured power leg to the #2 terminal to prevent damage.



**Figure 50.** G0623X3 power connection terminals.

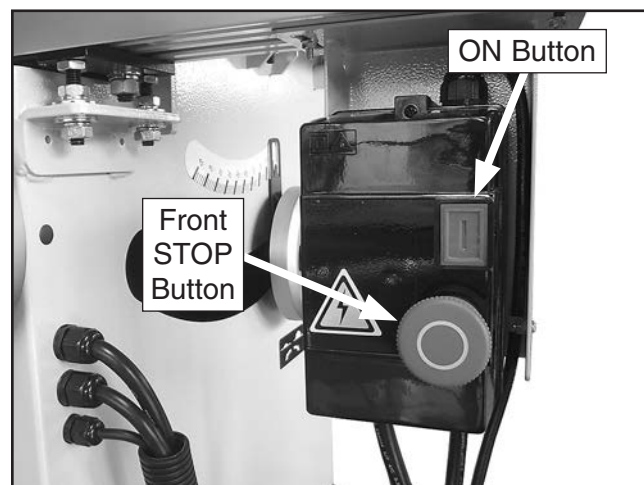
4. Tighten strain relief on bottom of connection box against power cord (G0623X or G0623X3, 230V/220V) or conduit (G0623X3, 440V)—not directly against power cord or wires—then close cover. Leave a little slack in wires inside box.

## Test Run

After the machine has been connected to the power source, the machine **MUST** be test run to make sure all the controls and safety components function properly before the machine is placed into regular operation.

It is extremely important that all steps in this section be followed very closely, in the order given, to ensure that the safety features are tested correctly.

Before beginning the test run, review the power controls shown in **Figure 51** and **Identification** on **Page 3**.



**Figure 51.** Main power controls.

### **!WARNING**

If the machine does not operate as stated in this section, review the Troubleshooting section on Page 69. If you need additional help, call Tech Support at (570) 546-9663. **DO NOT** place a machine into regular operation if you suspect that it is malfunctioning, or serious injury could occur.



### To test run the machine:

1. Put on safety glasses, make sure any bystanders are out of the way, and that all tools have been removed from saw.
2. Push in, then rotate both STOP buttons clockwise until they pop out. This resets switch so machine can be started.
3. Press ON button. Blades should start up and run smoothly without any problems. *If any problems occur, immediately press the STOP button.*
4. Press STOP button. As main blade comes to a stop, watch the direction that it spins.

—The main blade should spin clockwise if you are standing at the front of the machine. If this is true, continue to **Step 5**.

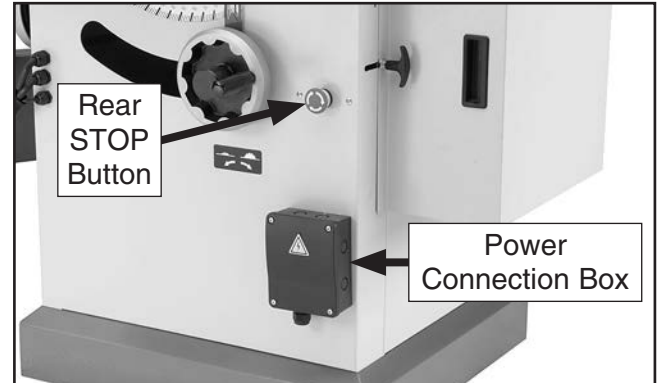
—If the main blade rotates counterclockwise, disconnect the saw from power and exchange wires R & T in the power connection box to change the motor direction (Model G0623X3 only). After exchanging the wires and closing the power connection box, connect the saw to power, and repeat **Steps 3–4**.

5. Make sure STOP button is pushed in, then press ON button.

—The saw should NOT start if the disabling feature on the STOP button is working correctly. If this is true, continue to **Step 6**.

—If the saw DOES start when the STOP button is pushed in, then the safety feature on the STOP button is not working correctly. Call Tech Support for advice before proceeding any further with the test run or machine operations.

6. Rotate STOP button clockwise so it pops out, then repeat **Step 5** on rear STOP button (see **Figure 52**).



**Figure 52.** Rear STOP button location.

7. DISCONNECT MACHINE FROM POWER!
8. Move sliding table all the way forward, then open orange blade guard (refer to **Page 43** for details on accessing and opening blade guard). Opening blade guard triggers limit switch.
9. Connect saw to power source.
10. (During this step, be prepared to immediately press STOP button if blades start operating.) Press ON button.

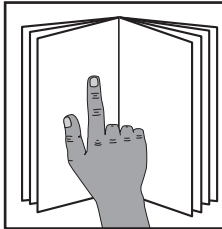
—If the blade guard limit switch functions correctly, the machine will not start. If this is true, continue to **Step 10**.

—If the machine starts during this test, the limit switch is NOT functioning correctly. Disconnect the saw from power, and call Tech Support for advice before proceeding any further with the test run or machine operations.

11. Close orange blade guard and move sliding table back to center of machine.



# SECTION 4: OPERATIONS

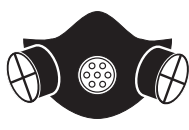


## **!WARNING**

To reduce your risk of serious injury, read this entire manual **BEFORE** using machine.

## **!WARNING**

Eye injuries, respiratory problems, or hearing loss can occur while operating this tool. Wear personal protective equipment to reduce your risk from these hazards.



## **!WARNING**

**For Your Own Safety Read Instruction Manual Before Operating Saw**

- Wear eye protection.
- Use saw-blade guard and splitter/riving knife for every operation for which it can be used, including all through sawing.
- Keep hands out of the line of saw blade.
- Use a push-stick when required.
- Pay particular attention to instructions on reducing risk of kickback.
- Do not perform any operation freehand.
- Never reach around or over saw blade.

## **NOTICE**

If you are not experienced with this type of machine, **WE STRONGLY RECOMMEND** that you seek additional training outside of this manual. Read books/magazines or get formal training before beginning any projects. Regardless of the content in this section, Grizzly Industrial will not be held liable for accidents caused by lack of training.

## Operation Overview

The purpose of this overview is to provide the novice machine operator with a basic understanding of how the machine is used during a typical operation, so the controls/components discussed later in this manual are easier to understand.

Due to the generic nature of this overview, it is not intended to be an instructional guide. To learn more about specific operations, read this entire manual, read "how to" books, and seek additional training from experienced machine operators.

**To complete a typical operation, the operator does the following:**

- Examines the workpiece to make sure it is suitable for cutting.
- Adjusts the blade tilt, if necessary, to the correct angle of the desired cut.
- Adjusts the blade height approximately ¼" higher than the thickness of the workpiece.
- Adjusts the fence to the desired width of cut then locks it in place.
- Checks the outfeed side of the machine for proper support and to make sure the workpiece can safely pass all the way through the blade without interference.
- Puts on safety glasses, respirator, and hearing protection. Locates push sticks, if needed.
- Turns on dust collection system.
- Feeds workpiece all the way through blade while maintaining firm pressure on workpiece against table and fence.
- Turns machine **OFF** immediately after cut is complete and waits for blades to completely stop before removing workpiece.



# Workpiece Inspection

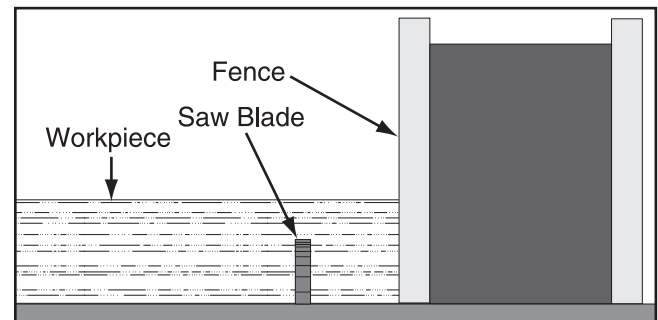
Some workpieces are not safe to cut on this machine or may need to be modified before they can be safely cut. **Before cutting, inspect all workpieces for the following:**

- **Material Type:** This machine is intended for cutting natural and man-made wood products, laminate-covered wood products, and some plastics. Cutting drywall or cementitious backer board creates extremely fine dust and may reduce the life of the motor bearings. This machine is NOT designed to cut metal, glass, stone, tile, etc.; cutting these materials with a table saw greatly increases the risk of injury and damage to the saw or blade.
- **Foreign Objects:** Nails, staples, dirt, rocks and other foreign objects are often embedded in wood. While cutting, these objects can become dislodged and hit the operator, cause kickback, or break the blade, which might then fly apart. Always visually inspect your workpiece for these items. If they can't be removed, DO NOT cut the workpiece.
- **Large/Loose Knots:** Loose knots can become dislodged during the cutting operation. Large knots can cause kickback and machine damage. Choose workpieces that do not have large/loose knots or plan ahead to avoid cutting through them.
- **Wet or "Green" Stock:** Cutting wood with a moisture content over 20% causes unnecessary wear on the blades, increases the risk of kickback, and yields poor results.
- **Excessive Warping:** Workpieces with excessive cupping, bowing, or twisting are dangerous to cut because they are unstable and may move unpredictably when being cut.
- **Minor Warping:** Slightly cupped workpieces can be safely supported with cupped side facing the table or fence; however, workpieces supported on the bowed side will rock

# Non-Through & Through Cuts

## Non-Through Cuts

A non-through cut is a sawing operation where the blade does not protrude above the top face of the wood stock, as shown in the **Figure** below.



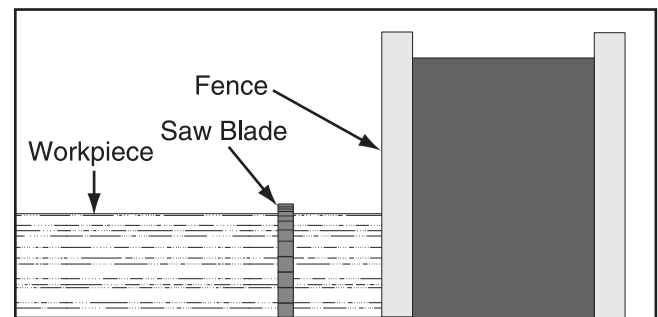
**Figure 53.** Example of a non-through cut.

Examples of non-through cuts include dados and rabbets. Non-through cuts have a higher risk of injury from kickback because the blade guard must be removed. However, the riving knife **MUST** be installed because it still provides some protection.

**IMPORTANT:** When making non-through cuts with a dado blade, do not attempt to cut the full depth in one pass. Instead, take multiple light passes to reduce the load on the blade.

## Through Cuts

A through cut is a sawing operation in which the workpiece is completely sawn through, as shown in the **Figure** below. Examples of through cuts are rip cuts, cross cuts, miter cuts, and beveled cuts. The blade guard assembly **MUST** be used when performing through cuts.

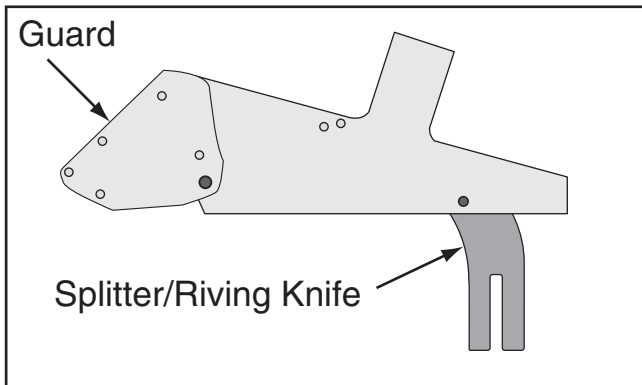


**Figure 54.** Example of a through cut (blade guard not shown for illustrative clarity).



# Blade Guard & Splitter/Riving Knife

The term "blade guard" refers to the assembly that consists of the guard and splitter/riving knife assembly (see **Figure 55** below). Each of these components have important safety functions.



**Figure 55.** Blade guard assembly components.

## Understanding the Blade Guard

The guard encloses the top of the blade to reduce the risk of accidental blade contact and contain flying chips or dust.

The guard is designed to lift as the workpiece is pushed into the blade, remain in contact with the workpiece during the cut, then return to a resting position against the table when the cut is complete. When installed and properly maintained, the guard is an excellent tool for reducing the risk of injury when operating the table saw.

To ensure that the guard does its job effectively, it **MUST** be installed and adjusted so that it moves up and down properly to accommodate workpieces and maintain coverage over the blade.

## Understanding Splitter/Riving Knife

The splitter/riving knife is a metal plate that prevents the freshly cut pieces of the workpiece from pinching the backside of the blade and causing a kickback. It also acts as a barrier behind the blade to shield hands from being pulled into the blade if a kickback occurs and the operator is reaching behind the blade. (Reaching behind the blade is a major safety risk and should not be done).

## **!WARNING**

To ensure that the splitter/riving knife works safely, it **MUST** be aligned with and correctly adjusted to the blade.

## When to Use the Blade Guard

The blade guard **MUST** be installed on the saw for all normal through cuts (defined on owner's manual **Page 37**).

Sometimes the blade guard or its components can get in the way when cutting very narrow workpieces or other specialized cuts. Because the blade guard is provided to decrease your risk of injury, it should not be used if it gets in the way of making a safe cut. Use good judgment!

In general, the blade guard **MUST** remain installed on the saw—unless a specific operation requires its removal. If the blade guard is removed for specific operations, always immediately replace it after those operations are complete.

## When to Use Riving Knife Only

Use the splitter/riving knife without the blade guard for any non-through cuts (defined on owner's manual **Page 37**) or narrow/specialized cuts in which the blade guard gets in the way of a safe cut.

Always immediately replace the blade guard when these cuts are complete!

## When Not to Use Riving Knife

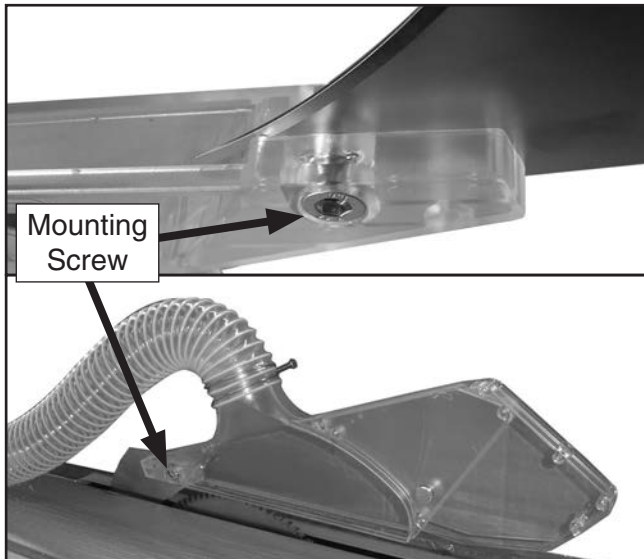
If you use a dado blade that has a diameter smaller than 10", the splitter/riving knife will be taller than the top of the blade, which will prevent the cut from being completed. In this case, the only way to complete the cut is to remove the splitter/riving knife.





## Blade Guard Installation & Removal

The blade guard fits over the splitter/riving knife and is secured in place with an M10-1.5 x 25 cap screw and an M10-1.5 lock nut (see "Mounting Screw" in **Figure 56**). These are the only fasteners that need to be installed/removed when installing or removing the blade guard.



**Figure 56.** Blade guard mounted to riving knife.

When installing the blade guard, the mounting screw and lock nut must be left loose enough that the guard can freely pivot up and down, but not so loose that there is side-to-side play when pivoting.

## Testing Guard for Correct Operation

After installing the blade guard, you must verify that it functions correctly before making a cut. To test the blade guard operation, lift up the front end about 4" then release it.

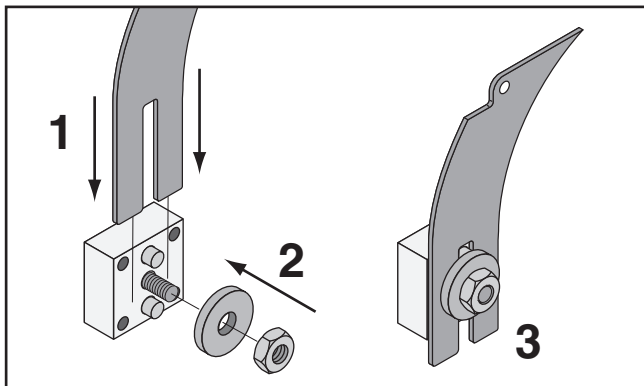
- If the blade guard freely drops down against the table surface, then it is functioning correctly and is ready for operation.
- If the blade guard remains in the position where you released it, or it does not drop down against the surface of the table, then the mounting screw and lock nut are too tight. Loosen it slightly and repeat this test until the guard functions correctly.
- If the blade guard feels loose and easily moves back and forth as you raise it, then the mounting screw and lock nut are too loose. Tighten it slightly and repeat this test until the guard functions correctly.



## Splitter/Riving Knife Installation & Removal

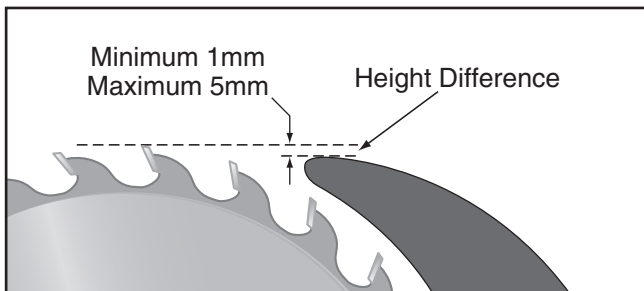
The splitter/riving knife must be correctly installed, adjusted, and aligned in order to provide the maximum safety benefit.

The splitter/riving knife attaches to the mounting block as shown in **Figure 57**. Always firmly tighten the hex nut when securing the splitter/riving knife in place.



**Figure 57.** Installing splitter/riving knife on mounting block.

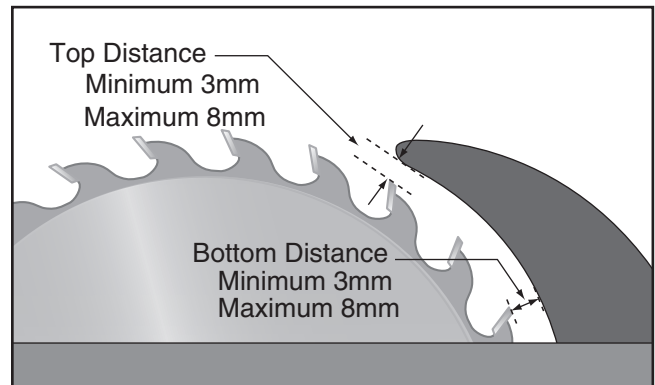
Secure the splitter/riving knife so that the top of it is 1–5mm below the top level of the blade, as shown in **Figure 58**.



**Figure 58.** Height difference between splitter/riving knife and blade.

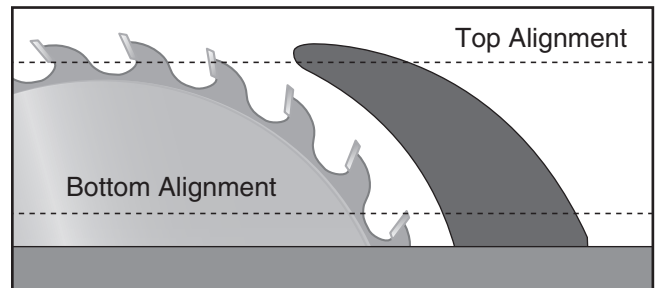
The height difference between the splitter/riving knife and the blade allows the workpiece to pass over the blade during non-through cuts (those in which the blade does not cut all the way through the thickness of the workpiece).

The splitter/riving knife also prevents the freshly cut sides of the workpiece from pinching the blade and causing kickback. For maximum effectiveness of this safety design, the splitter/riving knife must be positioned within 3–8mm from the blade, as shown in **Figure 59**.



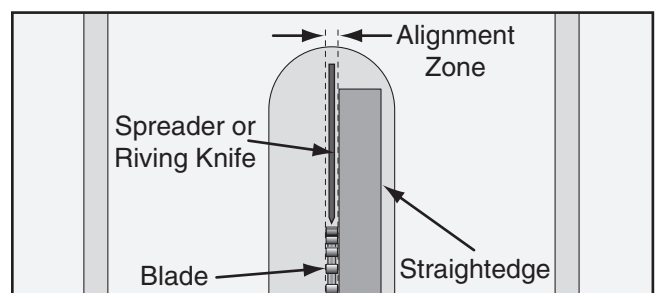
**Figure 59.** Allowable top and bottom distances between splitter/riving knife and blade.

Once the splitter/riving knife is properly positioned at the correct distance from the blade, verify that it is aligned with the blade by checking the alignment with a straightedge in the top and bottom locations shown in **Figure 60**.



**Figure 60.** Checking top and bottom splitter/riving knife alignment with blade.

The splitter/riving knife should be parallel with the blade along its length at both positions and should be in the "Alignment Zone" shown in **Figure 61**.



**Figure 61.** Verifying that splitter/riving knife is in the alignment zone behind the blade.

If the splitter/riving knife is not aligned or parallel with the blade, refer to **Splitter/Riving Knife Mounting Block** on **Page 76**.



# Safety Tips

---

Your safety is important. The tips below are intended to supplement **SECTION 1: SAFETY**. But remember, no safety list can cover every situation. The operator is ultimately responsible for their own safety, as well as the safety of bystanders. Every cutting operation is uniquely different and may require safety equipment or safety procedures not mentioned in this manual.

**Please follow these safety tips EVERY time you use your saw:**

- Stand to the left of the blade line-of-cut when performing a cutting operation.
- Turn **OFF** the saw and allow the blade to come to a complete stop before removing cut-off pieces.
- Make sure that the splitter/riving knife is always aligned with the main blade before cutting!
- Always position the blade guard to the correct height above the workpiece.
- Carefully plan each cutting operation to avoid injuries.
- When you release the sliding table lock, make sure that the knob is positioned so that it will not lock the table during a cut.
- Plan your cut to avoid putting your hands near the blade or reaching across the blade.

# Blade Requirements

---

The splitter/riving knife included with this machine is 0.090" (2.3mm) thick and is only designed for 10" diameter blades.

When choosing a main blade, make sure the blade size meets the requirements listed below. The thickness of the blade body and teeth can be measured with calipers or any precision measuring device.

## Blade Size Requirements:

- Body Thickness: 0.079"–0.090" (2.0mm–2.3mm)
- Kerf (Tooth) Thickness: 0.122"–0.129" (3.1mm–3.3mm)

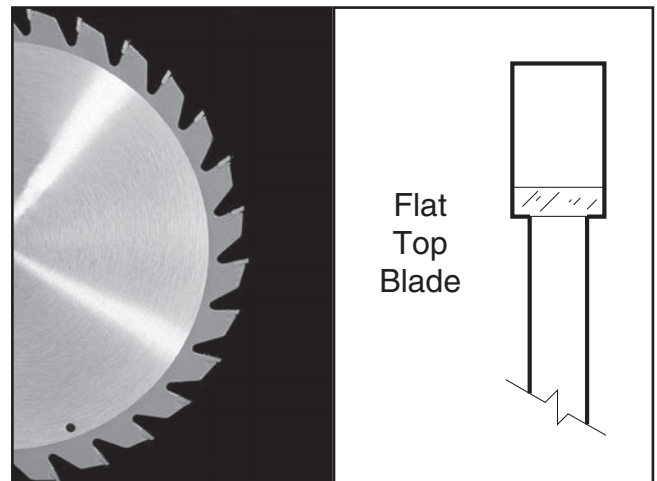
# Blade Selection

---

This section on blade selection is by no means comprehensive. Always follow the saw blade manufacturer's recommendations to ensure safe and efficient operation of your table saw.

## Ripping Blade Features:

- Best for cutting with the grain
- 20-40 teeth
- Flat-top ground tooth profile
- Large gullets for large chip removal



**Figure 62.** Ripping blade.



### Crosscut blade features:

- Best for cutting across the grain
- 60-80 teeth
- Alternate top bevel tooth profile
- Small hook angle and a shallow gullet

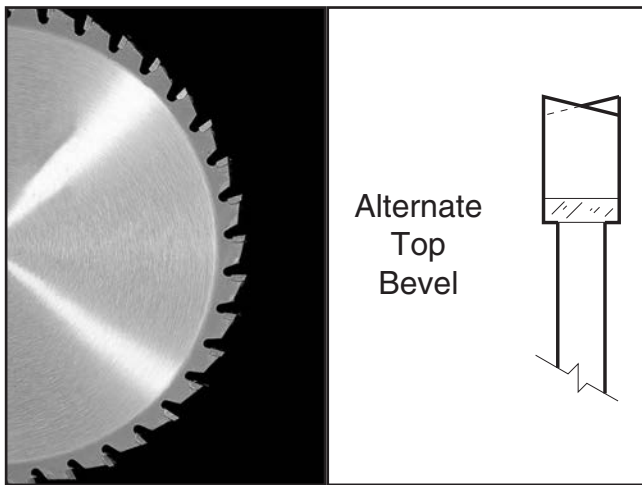


Figure 63. Crosscutting blade.

### Laminate blade features:

- Best for cutting plywood or veneer
- 40-80 teeth
- Triple chip tooth profile
- Very shallow gullet

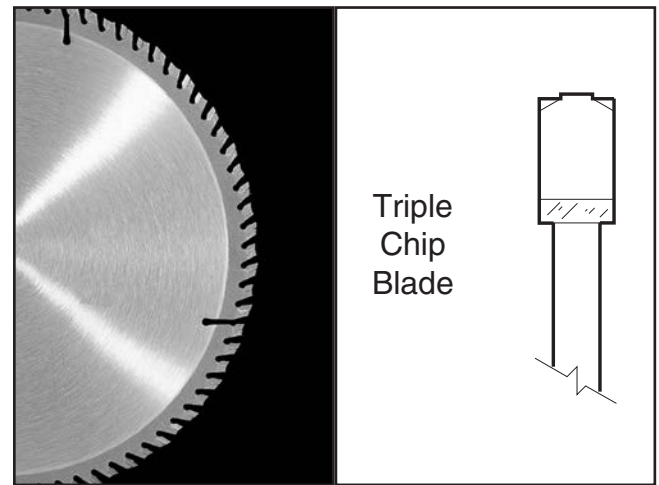


Figure 65. Laminate blade.

### Combination blade features:

- Designed to cut both with and across grain
- 40-50 teeth
- Alternate top bevel and flat, or alternate top bevel and raker tooth profile
- Teeth are arranged in groups
- Gullets are small and shallow (similar to a cross-cut blade), then large and deep (similar to a ripping blade)

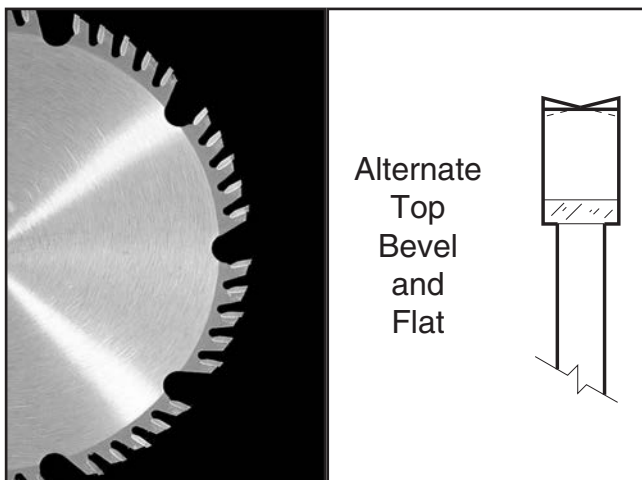


Figure 64. Combination blade.

**Thin Kerf Blade:** A blade with thinner kerf than a standard blade. Since the spreader/riving knife included with this table saw is sized for standard blades, thin kerf blades cannot be used on this saw unless they meet the **Blade Requirements** specified in this manual; otherwise, they will increase the risk of kickback.

### Dado Blades

**Stacked Dado Blade (see below):** Multiple blades are stacked together to control the cutting width. Stacked dado blades are more expensive than wobble blades, but typically produce higher quality results.

**Wobble Dado Blade:** A single blade mounted at a slight angle on an arbor hub. The blade angle is adjustable on the hub, and the width of the dado cut is controlled by the angle setting of the blade.

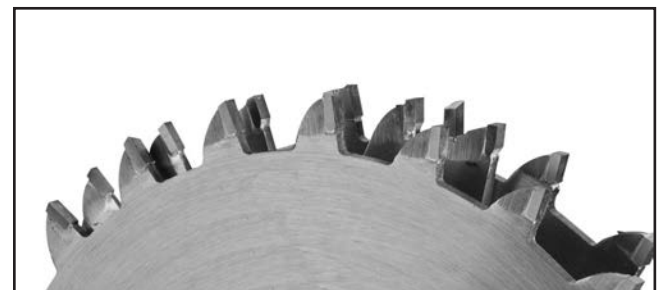


Figure 66. Stacked dado blade.

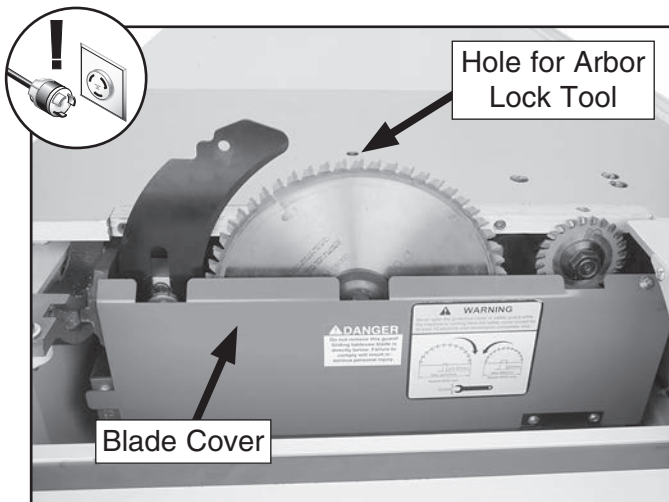


# Changing Main Blade

This saw performs best with high-quality sharp blades. Whenever the blades become dull, replace or have them sharpened.

## To change the main blade:

1. DISCONNECT MACHINE FROM POWER!
2. Move blade tilt to 0° (blade 90° to table) and raise main blade as far as it will go.
3. Move sliding table out of the way to expose lower blade cover that covers blades and splitter/riving knife, as shown in **Figure 67**.



**Figure 67.** Blade cover made accessible with sliding table moved out of the way.

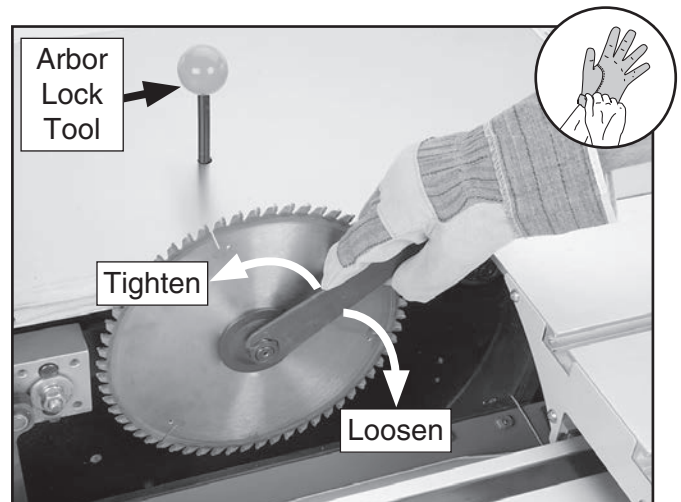
4. Pull blade cover away from blades to expose mounting assembly (blade cover is held closed with a magnet).

## ⚠ CAUTION

Before proceeding with the next step, wear gloves to protect your hands while handling and installing the blade.

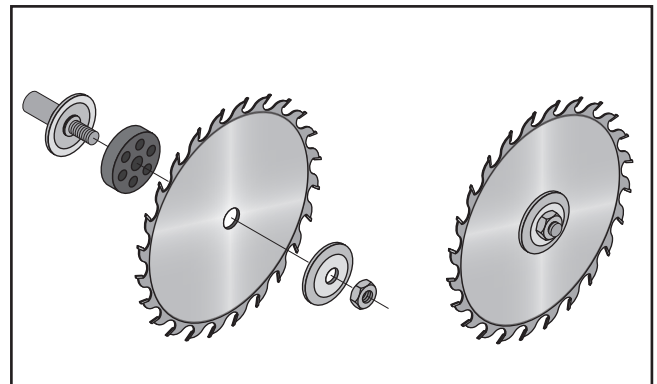
5. Insert arbor lock tool into hole shown in **Figure 67**, then rotate blade by hand until arbor lock tool seats.

6. Use arbor wrenches to remove arbor nut and arbor flange, as shown in **Figure 68**, then pull old blade off the arbor. *Arbor nut has left-hand threads and loosens by turning clockwise.*



**Figure 68.** Replacing the main blade.

7. Install blade as shown in **Figure 69**, making sure teeth face toward scoring blade. DO NOT overtighten arbor nut.



**Figure 69.** Main blade installation and order of assembly.

— If you changed the diameter of the blade during this procedure, adjust the splitter/riving knife according to **Splitter/Riving Knife Installation & Removal on Page 76**.

8. Move blade cover back into its original position next to blades, then center sliding table.

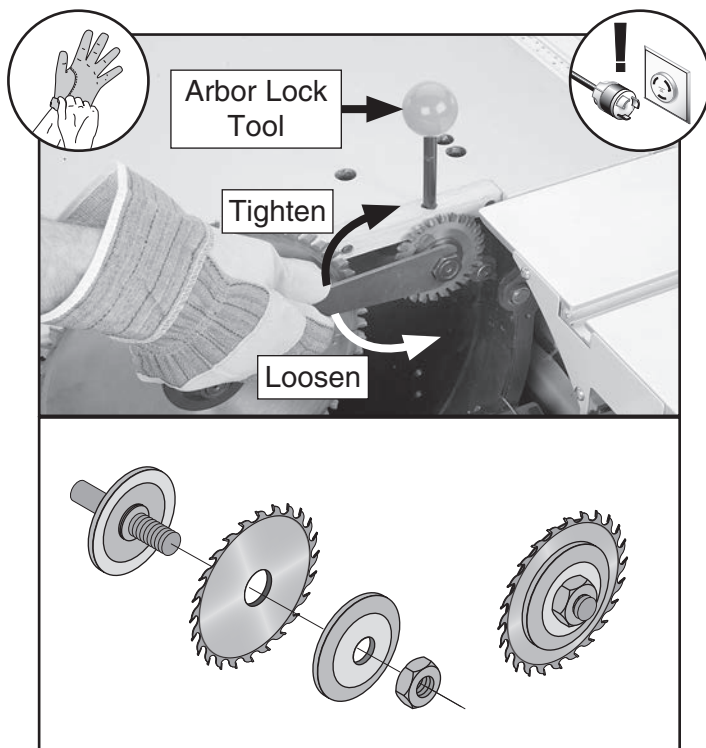


# Changing/Adjusting Scoring Blade

The scoring blade included with the Model G0623X/G0623X3 has wedge shaped teeth. With this style of scoring blade, the kerf thickness is adjusted by changing the height of the scoring blade. Raising the scoring blade higher increases the kerf thickness.

## Changing Scoring Blade

1. DISCONNECT MACHINE FROM POWER!
2. Remove blade guard and move blade tilt to 0° (blade 90° to table).
3. Move sliding table to side and pull blade cover open.
4. Insert arbor lock tool in table, rotate scoring blade to seat arbor lock tool, and use arbor wrenches to remove arbor nut and scoring blade (see **Figure 70**).

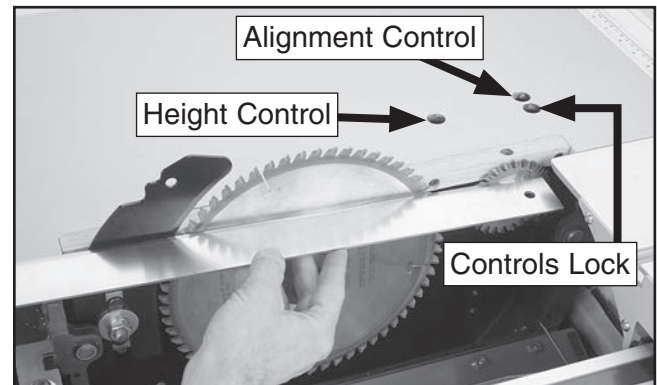


**Figure 70.** Removing/installing scoring blade.

5. Install new scoring blade as shown in **Figure 70**, tighten arbor nut, and adjust scoring blade alignment and height as necessary.

## Adjusting Scoring Blade

1. DISCONNECT MACHINE FROM POWER!
2. Unlock scoring blade controls by inserting 6mm hex wrench into controls lock hole shown in **Figure 71** and turning mechanism inside counterclockwise until loose.



**Figure 71.** Checking and adjusting scoring blade positioning.

3. Place straightedge across body of main blade (not the teeth) and align body of scoring blade to main blade by turning alignment control (**Figure 71**) with 6mm hex wrench.
4. Adjust height of scoring blade by turning height control (**Figure 71**) with a 6mm hex wrench, until exposed portion equals kerf thickness of main blade.

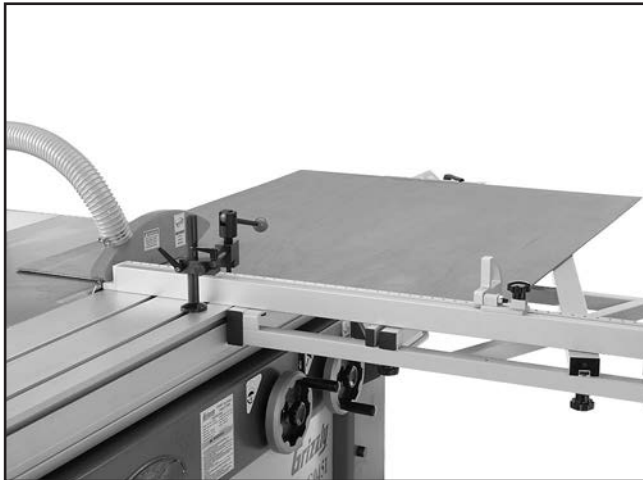
**Note:** The easiest way to match the scoring blade kerf is by laying a straightedge on the table, and placing it up against the main blade teeth and beyond the scoring blade, then adjusting the scoring blade height until its teeth align with the main blade teeth. Also check on the other side of the blades to verify that the kerf thickness matches and the scoring blade is aligned with the main blade.

5. Tighten controls lock.
6. Move blade cover back into its original position next to blades, then center sliding table.
7. Perform test cut and check for chip out on underside of test piece. If there is chip out, make adjustments necessary to match kerfs.



# Rip Cutting

This saw has the capability of rip cutting large panels (see **Figure 72**). The sliding table removes the burden of sliding a large and heavy panel over a stationary table surface.



**Figure 72.** Rip cutting with typical sliding table.

This saw also has the capability of rip cutting smaller boards, using the machine as a traditional table saw (see **Figure 73**). Smaller, lighter boards are easier to slide across the stationary cast iron table surface to the right of the saw blade.



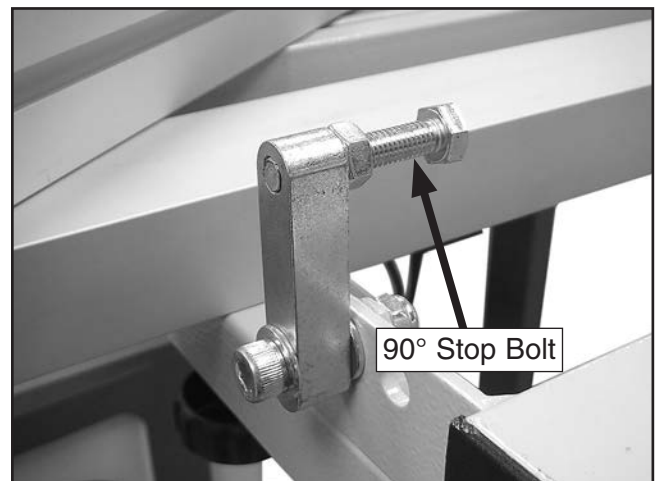
**Figure 73.** Traditional rip cutting using the miter gauge and rip fence.

Determine which cutting operation will be best suited for the workpiece to be ripped.

- To use the sliding table, read the instructions titled “Rip Cutting w/Sliding Table.”
- To use the machine as a traditional table saw, skip ahead to “Rip Cutting w/Rip Fence.”

## Rip Cutting with Sliding Table

1. Install crosscut fence on crosscut table, and rotate it until fence touches 90° stop bolt (**Figure 74**).



**Figure 74.** Place crosscut fence against 90° stop bolt.

2. Check to make sure fence is at 90° and, if necessary, adjust it as described in **Squaring Crosscut Fence to Blade** on **Page 75**.
3. Slide fence so plastic block on end is next to blade teeth—this calibrates scale to zero—then tighten lock knob.

**Note:** Avoid cutting the plastic block on the end of the fence.

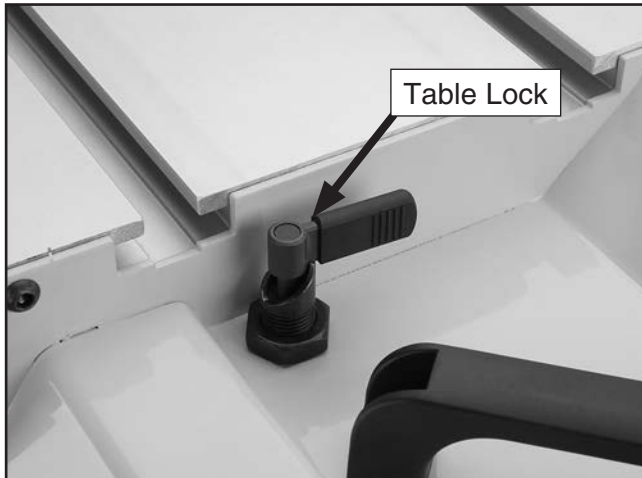
4. Set flip stop to desired width-of-cut.
5. Position blade guard to correct height for your workpiece.
6. Load workpiece onto table saw. Set up should look similar to **Figure 72**.
7. Take all necessary safety precautions, then perform cutting operation.



## Rip Cutting with Rip Fence

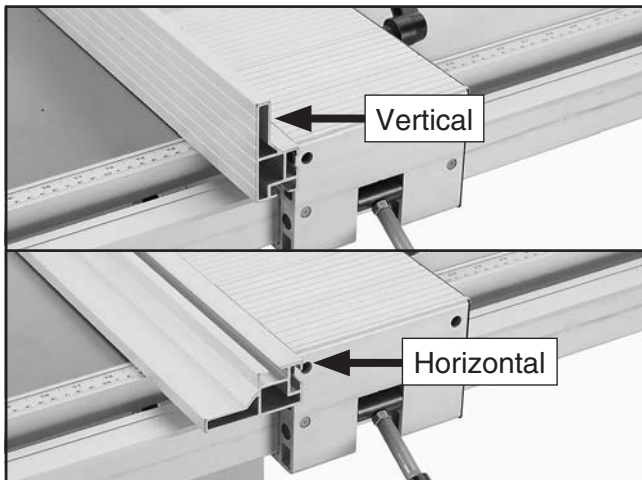
1. Slide crosscut table out of the way.
2. Lock sliding table into a stationary position (see **Figure 75**).

**Note:** The table will only lock in place when it is centered with the saw cabinet.



**Figure 75.** Sliding table lock.

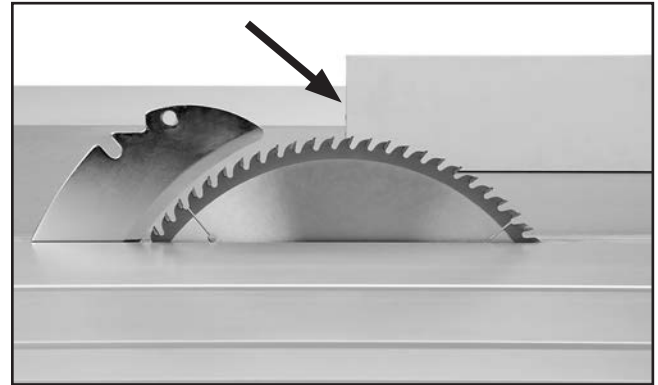
3. Place fence in vertical position for larger workpieces, or in horizontal position for angled cuts and for small workpieces (see **Figure 76**).



**Figure 76.** Rip fence positions.

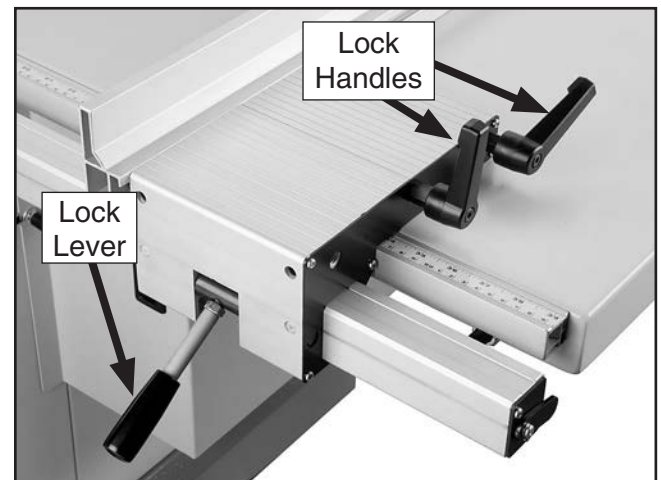
4. Slide leading end of rip fence so it is even with center of main saw blade as shown in **Figure 77**.

**Note:** This technique allows the finished cut-off piece to “fall” away from the blade when the cutting operation is complete; reducing the possibility of kickback.



**Figure 77.** Rip fence even with center of blade (blade guard removed for clarity).

5. Tighten lock handles (see **Figure 78**) to secure rip fence against base.



**Figure 78.** Rip fence micro-adjusting controls.

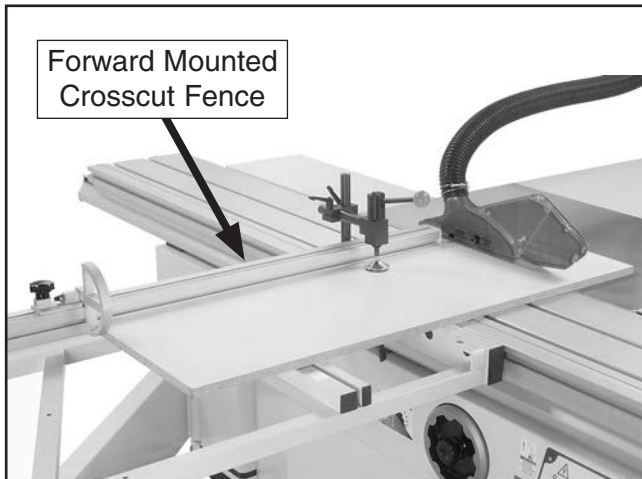
6. Pull up lock lever to loosen fence base on rail, position fence at correct distance away from blade (as needed for cut), then push down lock lever to lock fence base in position.
7. Take all necessary safety precautions, then make cut as you would with a traditional table saw.





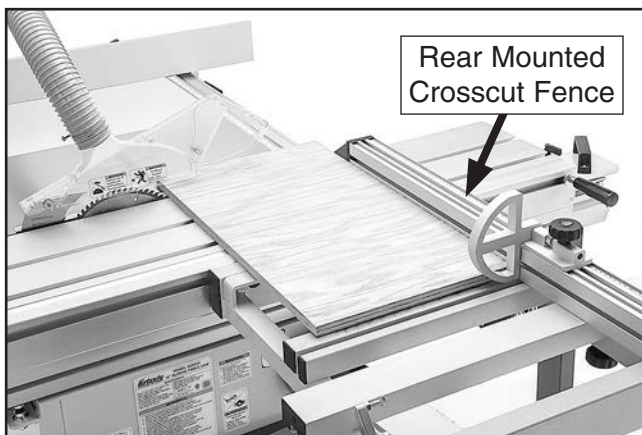
# Crosscutting

The Model G0623X/G0623X3 can crosscut full-size panels with the fence in the forward or rear position, although it is easier to load full-size panels with the crosscut fence mounted in the forward position (see **Figure 79**).



**Figure 79.** Crosscutting full-size panel.

Mounting the crosscut fence in the rear position (**Figure 80**) gives greater stability for crosscutting smaller panels.



**Figure 80.** Crosscutting smaller panels.

Additionally, this machine has the capability of crosscutting workpieces while using the rip fence as a cut-off gauge (**Figure 81**).



**Figure 81.** Crosscutting workpieces using the rip fence as a cut-off gauge.

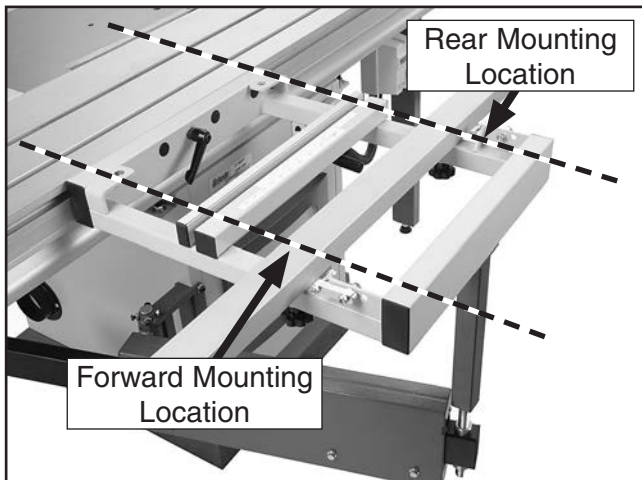
Determine which cutting operation will be best suited for the workpiece to be crosscut.

- If you will be crosscutting full-size panels, then skip ahead to **Crosscutting Full-Size Panels**.
- If you will be crosscutting smaller panels, then skip ahead to **Crosscutting Smaller Panels**.
- If you will be crosscutting workpieces using the rip fence as a cut-off gauge, then skip ahead to **Crosscutting Using Rip Fence as a Cut-Off Gauge**.



## Crosscutting Full-Size Panels

1. Install crosscut fence in forward mounting location shown in **Figure 82** and lock it in place.
2. Check to make sure fence is at 90° and adjust it as described in **Squaring Crosscut Fence to Blade** on **Page 75** if necessary.



**Figure 82.** Crosscut fence mounting points.

3. Set either flip stop to desired width-of-cut.  
**Note:** *Extend the crosscut fence slide if the workpiece is more than 74".*
4. Load workpiece onto table saw. Setup should look similar to **Figure 79**.
5. Once all necessary safety precautions have been taken, perform cutting operation.

## Crosscutting Smaller Panels

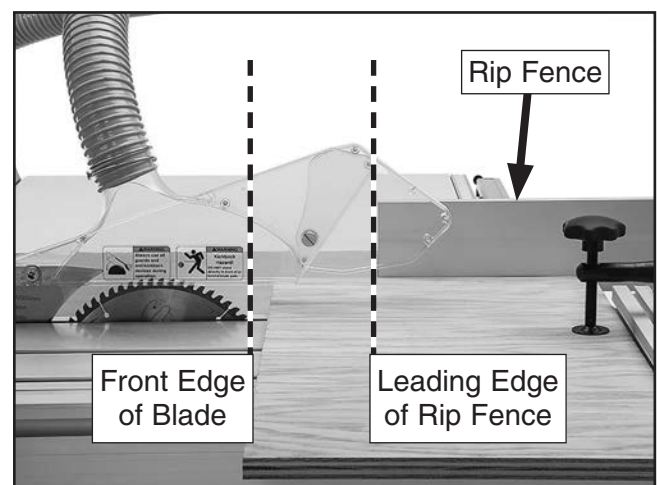
1. Install crosscut fence in rear mounting points shown in **Figure 82** and lock it in place.
2. Check to make sure fence is at 90° and adjust it as described in **Squaring Crosscut Fence to Blade** on **Page 75** if necessary.
3. Set either flip stop to desired width-of-cut.

**Note:** *Extend the crosscut fence slide if the workpiece is more than 74".*

4. Load workpiece onto table saw. Setup should look similar to **Figure 80**.
5. Once all necessary safety precautions have been taken, perform cutting operation.

## Crosscutting Using Rip Fence as a Cut-Off Gauge

1. Install crosscut fence in rear mounting points shown in **Figure 82** and lock it in place.
2. Check to make sure fence is at 90° and adjust it as described in **Squaring Crosscut Fence to Blade** on **Page 75** if necessary.
3. Position rip fence for desired width.
4. Load workpiece onto table saw. Setup should look similar to **Figure 81**.
5. Slide leading end of rip fence behind front edge of blade as shown in **Figure 83**. (**This step is critical to reduce the risk of blade binding and kickback.**)



**Figure 83.** Correct rip fence position when using it as a cut-off gauge.

6. Take all necessary safety precautions, then perform cutting operation.



# Miter Cutting

The crosscut fence allows miter cuts from 0° through 135°. The table mounted miter scale has a resolution of 1°.

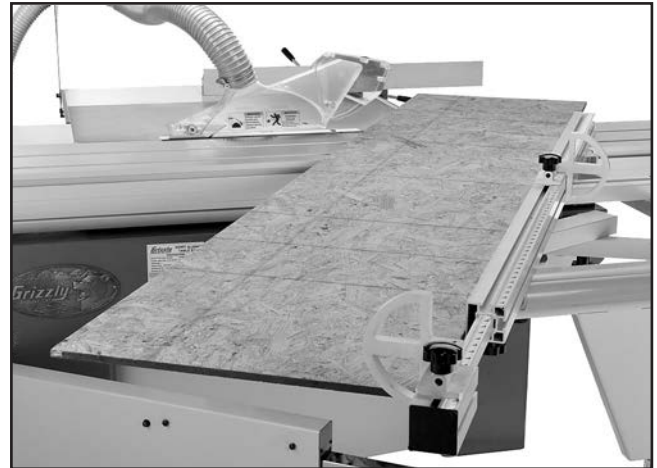
## To perform a miter cut:

1. Slide crosscut table to front edge of sliding table and lock it in place.
2. Place crosscut fence center stud in left or right stud hole of crosscut table. Fence can be installed as shown in **Figure 84** for 90° to 135° cuts, or as shown in **Figure 85** for 0° to 90° cuts.



**Figure 84.** Fence set-up for 90° to 135° cuts.

3. Rotate fence to desired angle and lock it in place.
4. Position flip stop according to length of workpiece you want to cut off to the left of the blade.
5. Load workpiece onto table saw. Setup should look similar to **Figure 85**.



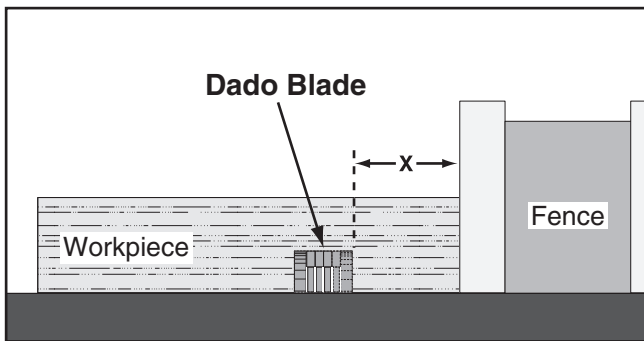
**Figure 85.** Example of miter cutting operation.

6. Once all necessary safety precautions have been taken, perform cutting operation.



# Dado Cutting

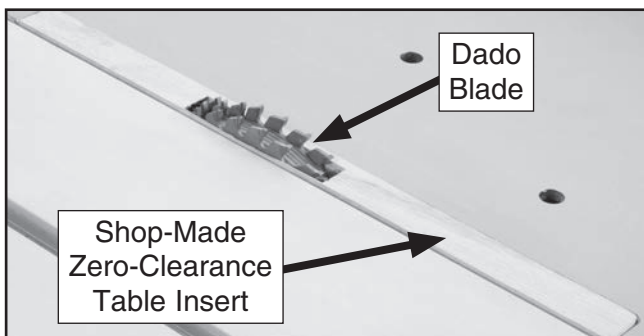
Commonly used in furniture joinery, a dado is a straight channel cut in the face of the workpiece. Dadoes are "non-through" cuts that can be made with a dado blade or a standard saw blade. The **Figure** below shows a cutaway view of a dado cut being made with a dado blade.



**Figure 86.** Example of a dado being cut with a dado blade.

This saw can only accept a dado blade with  $\frac{5}{8}$ " arbor hole and maximum width of  $\frac{13}{16}$ ". If you have any doubts or questions about the size of dado blade you want to install, call our Technical Support before proceeding.

In order to install a dado blade, the scoring blade should be removed and a zero-clearance table insert must be made specifically for the dado blade you will install (see **Figure 87**). Refer to **Zero-Clearance Insert** on **Page 61** for instructions on how to do this.

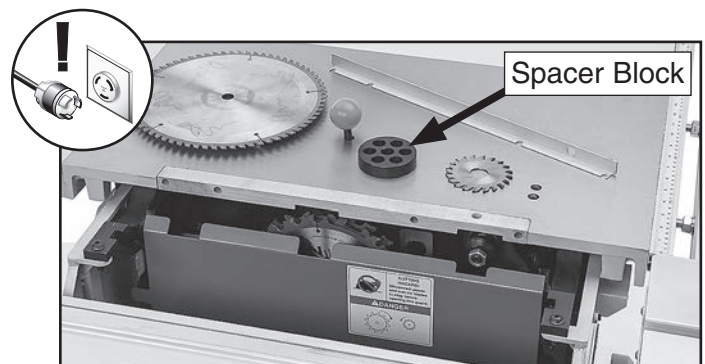


**Figure 87.** Dado blade raised into shop-made zero-clearance table insert.

If you plan on making dadoes at varying widths, we strongly recommend making a zero-clearance table insert for each thickness of dado blade that will be used.

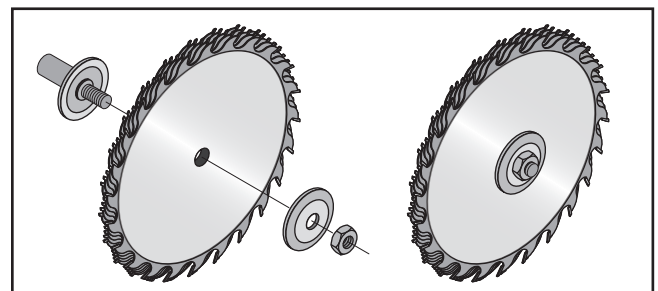
## Installing Dado Blade

1. DISCONNECT MACHINE FROM POWER!
2. Move sliding table out of the way to expose lower blade cover.
3. Remove standard blade. To loosen arbor nut, insert arbor lock tool that came with saw and turn arbor nut clockwise (it has left-hand threads).
4. Remove spacer block installed on arbor behind standard blade you removed in **Step 3**. Spacer block is not used when dado blades are installed (see **Figure 88**).



**Figure 88.** Dado blade installed on saw with new zero-clearance table insert.

5. Assemble/adjust dado blade system to desired width of cut, according to dado blade manufacturer's instructions.
6. Install dado blade on arbor shaft, as shown in **Figure 89**.



**Figure 89.** Installing a dado blade.

## **!**WARNING

**DO NOT** make through cuts with a dado blade. Dado blades are only intended for non-through cuts. Failure to heed this warning could result in serious injury.



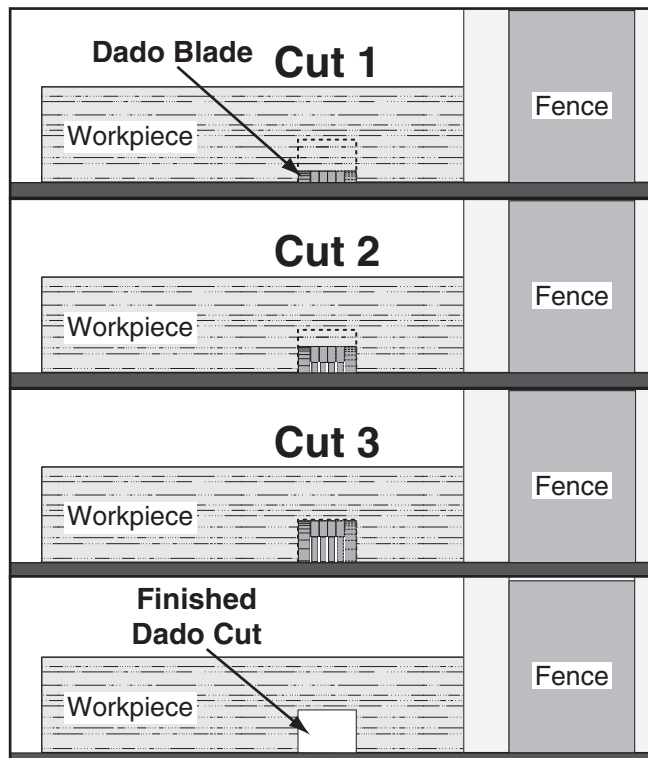
## Cutting Dados with a Dado Blade

Because dado blades are much wider than standard blades, they place a greater amount of force against the workpiece when cutting. This additional force increases the risk of kickback, requiring the operator to take additional steps when cutting to keep their injury risk at an acceptable level.

### **!WARNING**

**Dado blades have a higher risk of kickback than normal blades because their larger size applies stronger forces to the workpiece. This risk increases relative to the depth and width of the cut. To minimize your risk of serious personal injury, ensure that stock is flat and straight, and make multiple light cuts (rather than one deep cut) to achieve the desired cutting depth.**

The **Figure** below demonstrates the sequential process of making multiple, light cuts that get progressively deeper. The actual number of cuts used should be determined by workpiece hardness, total dado depth, and feed rate. In general, if you hear the motor slow down during the cut, you are cutting too deep or feeding too fast.



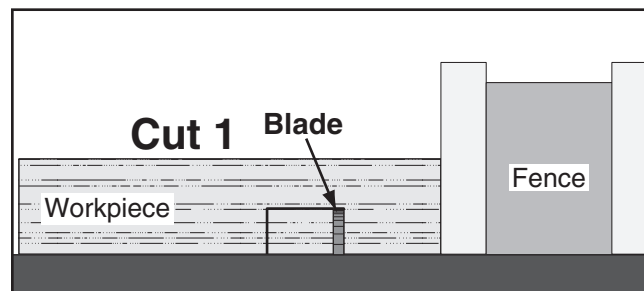
**Figure 90.** Example of dado being cut with multiple light cuts, instead of one deep cut.

## Cutting Dados with a Standard Blade

A ripping blade is typically the best blade to use for cutting dados when using a standard blade because it removes sawdust very efficiently. See **Page 45** for blade details.

**To use a standard saw blade to cut dados:**

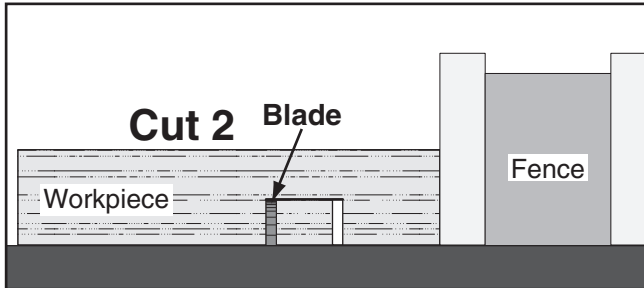
1. DISCONNECT MACHINE FROM POWER!
2. Mark width of dado cut on workpiece. Include marks on edge of workpiece so cut path can be aligned when workpiece is lying on table.
3. Raise blade up to desired depth of cut (depth of dado channel desired).
4. Set saw up for type of cut you need to make, depending on if it is a rip cut (**Page 45**) or crosscut (**Page 47**).
5. Align blade to cut one of the dado sides, as shown in **Figure 91**.



**Figure 91.** First cut for a single-blade dado.

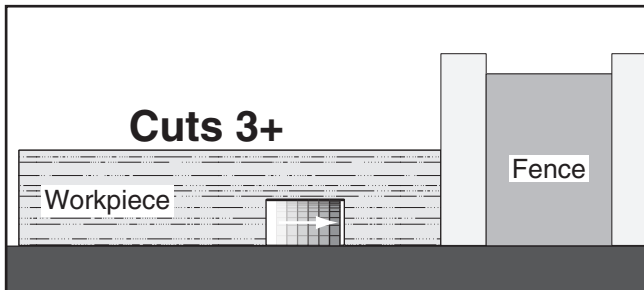


- Reconnect saw to power source and turn saw **ON**. Allow blade to reach full speed, then perform cutting operation.
- Repeat cutting operation on other side of dado channel, as in **Figure 92**.



**Figure 92.** Second cut for a single-blade dado.

- Make additional cuts in center of dado to clear out necessary material. The dado is complete when channel is completely cleared out.

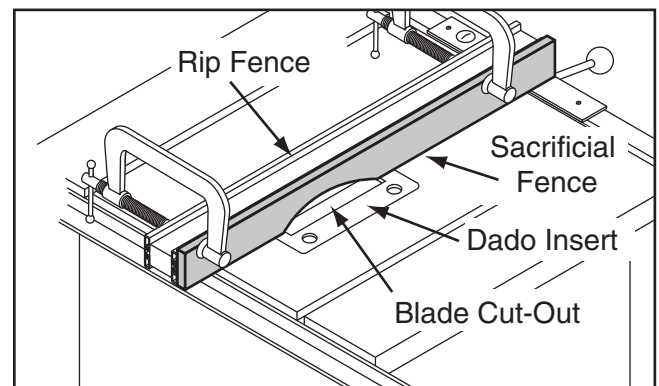


**Figure 93.** Successive cuts in the middle to complete the dado.

## Rabbet Cutting

Commonly used in furniture joinery, a rabbet is an L-shaped groove cut in the edge of the workpiece. Rabbets can be cut with either a dado blade or a standard saw blade.

Rabbet cutting on the edge of the workpiece with a dado blade requires a sacrificial fence (**Figure 94**). Make the sacrificial fence the same length as the fence and  $\frac{3}{4}$ " thick. Attach it to the fence with screws or clamps, making sure they are all secure and tight. Raise the blade into the sacrificial fence to the height needed.



**Figure 94.** Sacrificial fence.

### ⚠ WARNING

Dado blades have a higher risk of kickback than normal blades because their larger size applies stronger forces to the workpiece. This risk increases relative to the depth and width of the cut. To minimize your risk of serious personal injury, ensure that stock is flat and straight, and make multiple light cuts (rather than one deep cut) to achieve the desired cutting depth.

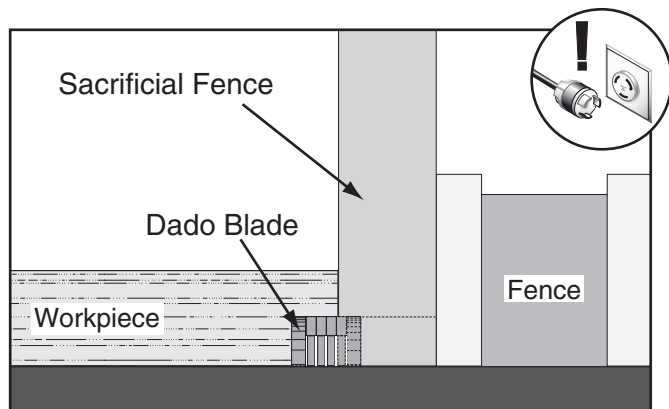
### ⚠ CAUTION

Always use push sticks, featherboards, push paddles and other safety accessories whenever possible to increase safety and control during operations which require that the blade guard to be removed from the saw. **ALWAYS** replace the blade guard after dadoing is complete.



## Cutting Rabbets with a Dado Blade

1. DISCONNECT MACHINE FROM POWER!
2. Adjust dado blade to height needed for rabbeting operation. When cutting deep rabbets, take more than one pass to reduce risk of kickback.
3. Adjust fence and align workpiece to perform cutting operation as shown in **Figure 95**.



**Figure 95.** Rabbet cutting with a dado blade.

4. Reconnect saw to power source and turn saw **ON**. When blade has reached full speed, perform test cut with scrap piece of wood.  
—If the cut is satisfactory, repeat the cut with the final workpiece.

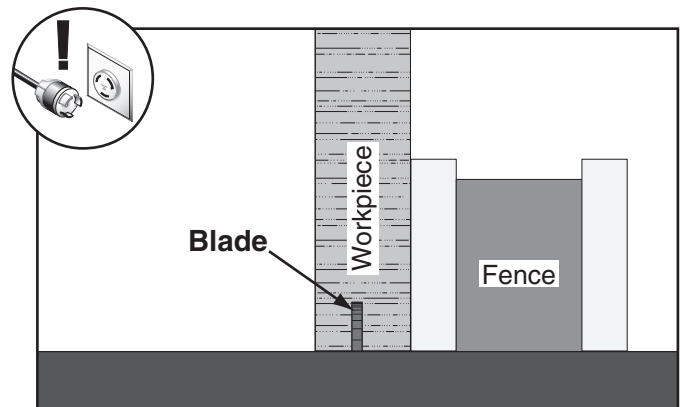
## Cutting Rabbets with a Standard Blade

A ripping blade is typically the best blade to use for cutting rabbets when using a standard blade because it removes sawdust very efficiently. (See **Page 45** for blade details.) Also, a sacrificial fence is not required when cutting rabbets with a standard blade.

### To cut rabbets with the standard blade:

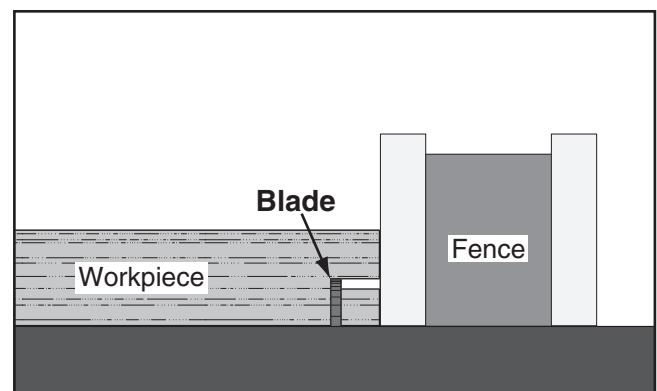
1. DISCONNECT MACHINE FROM POWER!
2. Mark width of rabbet cut on edge of workpiece, so you can clearly identify intended cut while it is laying flat on saw table.

3. Raise blade up to desired depth of cut (depth of rabbet channel desired).
4. Adjust fence so blade is aligned with inside of your rabbet channel as shown in **Figure 96**.



**Figure 96.** Rabbet cutting with a standard blade.

5. Reconnect saw to power source and turn saw **ON**. When blade has reached full speed, perform test cut with scrap piece of wood.  
—If the cut is satisfactory, repeat the cut with the final workpiece.
6. Lay workpiece on its side, as shown in **Figure 97**, adjust saw blade height to intersect with first cut, and perform second cut to complete the rabbet.



**Figure 97.** Second cut to create a rabbet.



# Resawing

## **!WARNING**

Resawing operations require proper procedures to avoid serious injury. Extra care must be taken to prevent kickback when resawing. Any tilting or movement of the workpiece away from the fence will cause kickback. Be certain that stock is flat and straight. Failure to follow these warnings could result in serious personal injury.

Resawing is the process of cutting a thick piece of stock into one or more thinner pieces. Although resawing can be done with a table saw, we strongly recommend that you use a bandsaw instead.

A bandsaw is the ideal machine for resawing, and resawing with one is fairly easy and safe. A table saw is not intended for resawing, and resawing with one is difficult and dangerous due to the increased risk of kickback from binding and deep cuts, and the increased risk of injury from having to remove the guard.

If you insist on resawing with a table saw, DO NOT do so without using a resaw barrier and wearing a full face shield. The following instructions describe how to build a resaw barrier that can be used with the rip fence when resawing to reduce the risk injury.

**Note:** To determine the maximum resawing height for this table saw, find the maximum blade height, then double it and subtract  $\frac{1}{8}$ ".

## Making Resaw Barrier

The resaw barrier acts in tandem with the rip fence when resawing to provide tall support for the workpiece to minimize the probability of it binding against the blade and causing kickback.

Tools Needed:	Qty
Table Saw .....	1
Jointer and Planer .....	Recommended
Clamps .....	2 Minimum
Drill and Drill Bits .....	1

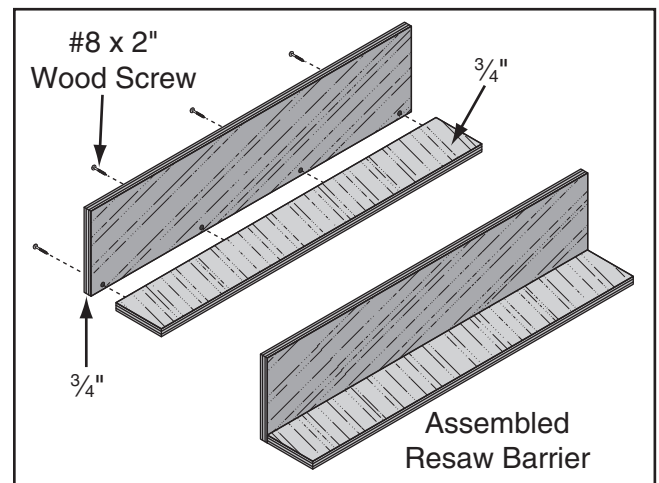
### Components Needed for Resaw Barrier:

Wood* $\frac{3}{4}$ " x $5\frac{1}{2}$ " x Length of Fence .....	1
Wood* $\frac{3}{4}$ " x 3" x Length of Fence .....	1
Wood Screws #8 x 2" .....	8
Wood Glue .....	As Needed

\* Only use furniture grade plywood or kiln dried hardwood to prevent warping.

### To build the resaw barrier:

1. Cut your wood pieces to size specified above. If you are using hardwood, cut pieces over-size, then joint and plane them to correct size to make sure they are square and flat.
2. Pre-drill and countersink four holes approximately  $\frac{3}{8}$ " from bottom of  $5\frac{1}{2}$ " tall wood piece.
3. Glue end of 3" board, then clamp boards at a  $90^\circ$  angle with larger board in vertical position, as shown in **Figure 98**, fasten together with wood screws.



**Figure 98.** Resaw barrier.





## Resawing Operations

The table saw motor is pushed to its limits when resawing. If the motor starts to bog down, slow down your feed rate. Motor overloading and blade wear can be reduced by using a ripping blade. Ripping blades are designed to clear the sawdust quickly.

### Components Needed for Resawing:

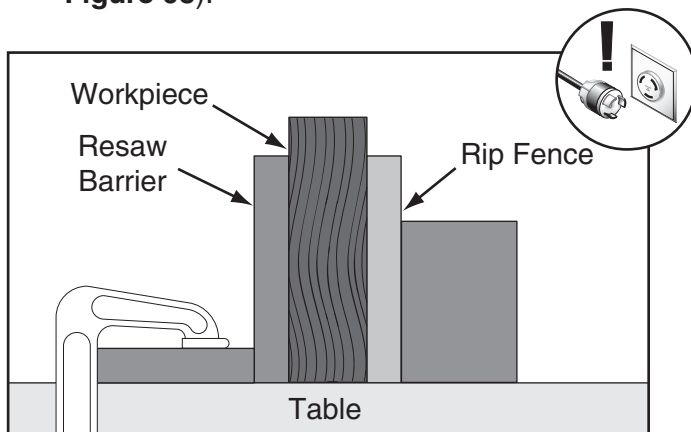
Zero-clearance Insert .....	1
Ripping Blade 10".....	1
Clamps .....	2
Shop Made Auxiliary Fence .....	1
Shop Made Resaw Barrier .....	1

## **!WARNING**

You may experience kickback during this procedure. Stand to the side of the blade path and wear safety glasses or a face shield to prevent injury.

### To perform resawing operations:

1. DISCONNECT MACHINE FROM POWER!
2. Install rip fence in vertical position.
3. Place workpiece against rip fence and slide resaw barrier against workpiece. Now clamp resaw barrier to top of the table saw (see **Figure 98**).



**Figure 99.** Resaw setup with barrier.

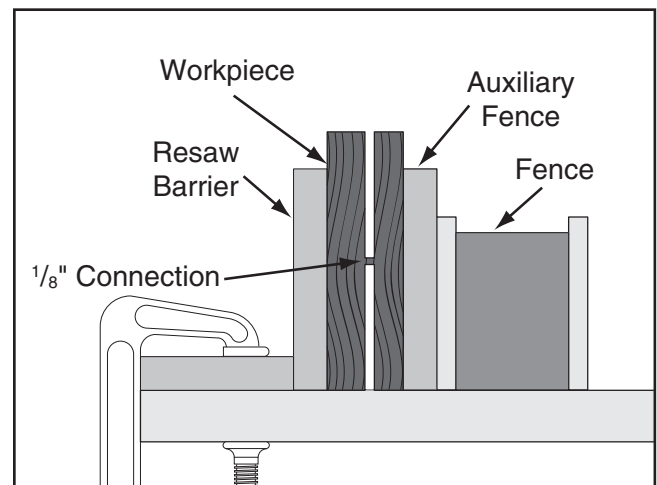
4. Lower blade completely below table, and slide workpiece over blade to make sure it moves smoothly and fits between resaw barrier and fence.

5. Raise blade approximately 1", or close to half the height of workpiece, whichever is less.

## **!WARNING**

Operations requiring the blade guard to be removed increase the risk of accidental contact with the blade. To reduce this risk, use push sticks/paddles and featherboards to keep your hands at a safe distance from the blade throughout the entire cut. Always replace guard after completing the cut!

6. Connect power to saw, turn it **ON**, and use push stick to feed workpiece through cut using a slow, steady feed rate.
7. Flip workpiece end for end, keeping same side against fence, and cut other side of workpiece.
8. Repeat **Steps 4–6** until blade is close to half of the height of the board to be resawn. The ideal completed resaw cut will leave a  $\frac{1}{8}$ " connection when resawing is complete as shown in **Figure 100**. Leaving a  $\frac{1}{8}$ " connection will reduce risk of kickback.



**Figure 100.** Ideal completed resaw cut.

9. Turn **OFF** table saw, then separate parts of workpiece and hand plane remaining ridge.
10. When finished resawing, remove resaw barrier and re-install blade guard/splitter.



# SECTION 5: SHOP-MADE SAFETY ACCESSORIES

## Featherboards

Easily made from scrap stock, featherboards provide an added degree of protection against kickback, especially when used together with push sticks. They also maintain pressure on the workpiece to keep it against the fence or table while cutting, which makes the operation easier and safer because the cut can be completed without the operator's hands getting near the blade. The angled ends and flexibility of the fingers allow the workpiece to move in only one direction.

### Making a Featherboard

This sub-section covers the two basic types of featherboards: 1) Those secured by clamps to the table or fence, or 2) those secured by a wood runner that mounts in the table saw miter slot.

#### Material Needed for Featherboard Mounted with Clamps

- Hardwood  $\frac{3}{4}$ " x 3" x 10" (Minimum)
- Hardwood  $\frac{3}{4}$ " x 6" x 28" (Maximum) ..... 1

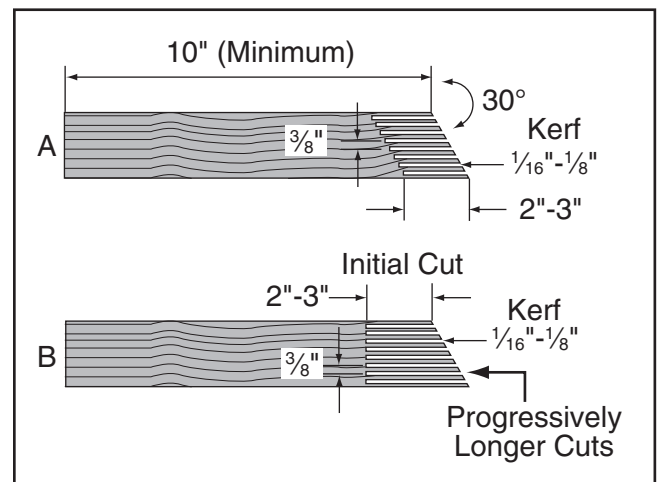
#### Material Needed for Featherboard Mounted in Miter Slot

- Hardwood  $\frac{3}{4}$ " x 3" x 10" (Minimum)
- Hardwood  $\frac{3}{4}$ " x 6" x 28" (Maximum) ..... 1
- Hardwood  $\frac{3}{8}$ " x (Miter Slot Width) x 5"L ..... 1
- Wing Nut  $\frac{1}{4}$ "-20..... 1
- Flat Head Screw  $\frac{1}{4}$ "-20 x 2" ..... 1
- Flat Washer  $\frac{1}{4}$ "-20..... 1

#### To make a featherboard:

1. Cut hardwood board approximately  $\frac{3}{4}$ " thick to size. Length and width of board can vary according to your design. Most featherboards are 10"–28" long and 3"–6" wide. Make sure wood grain runs parallel with length of featherboard, so the fingers you will create in **Step 3** will bend without breaking.

2. Cut a 30° angle at one end of board.
3. Make a series of end cuts with the grain  $\frac{3}{8}$ "– $\frac{1}{4}$ " apart and 2"–3" long, as shown in **Figure 101 (A)**. Alternatively, start cuts at 2"–3" deep, then make them progressively deeper, as shown in **Figure 101 (B)**. Cuts made across the grain will result in weak fingers that will easily break.



**Figure 101.** Patterns for featherboards (top view shown).

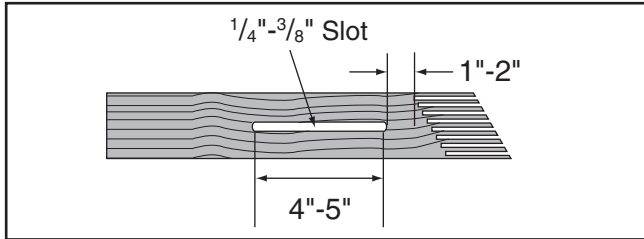
When complete, the fingers should flex when pushed with moderate pressure. If the fingers do not flex, they are too thick.

**Note:** We recommend using a bandsaw for making fingers because it tends to be safer. A table saw can be used, but it will over-cut the underside of the ends, produce a thicker kerf, and require you to stop the blade half-way through the cut, which can be dangerous.

If you are securing the featherboard with clamps, no further steps are necessary. Your featherboard is complete! If you are making a featherboard that mounts in the miter slot, continue with **Step 4**.



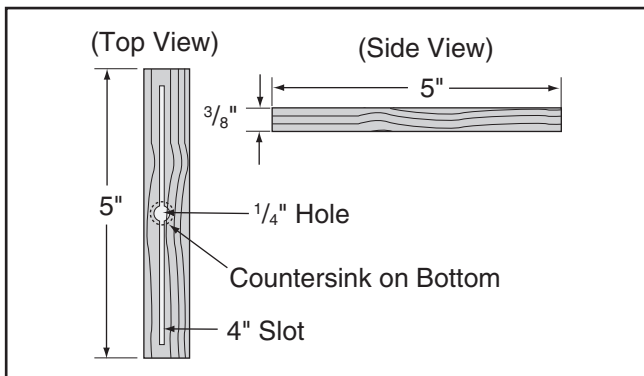
4. Rout a  $\frac{1}{4}$ "– $\frac{3}{8}$ " wide slot 4"–5" long in workpiece and 1"–2" from short end of featherboard (see **Figure 102**).



**Figure 102.** Slot routed in featherboard.

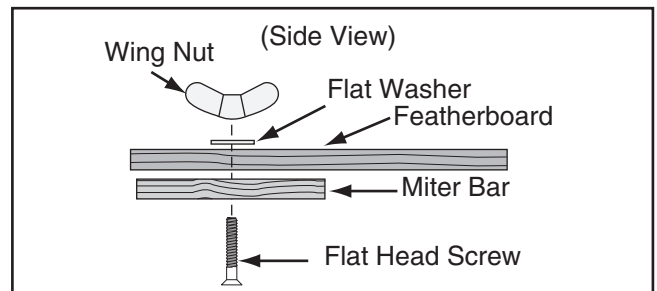
5. Cut a miter bar that will fit in table miter slot approximately 5" long (see **Figure 103**).

**Tip:** Consider making the miter bar longer for larger featherboards—approximately half the length of the total featherboard—to support the force applied to the featherboard during use.



**Figure 103.** Miter bar pattern.

6. Drill  $\frac{1}{4}$ " hole in center of bar, then countersink bottom to fit  $\frac{1}{4}$ "-20 flat head screw.
7. Mark 4" line through center of countersunk hole in center, then use jig saw with narrow blade to cut it out.
8. Assemble miter bar and featherboard with  $\frac{1}{4}$ "-20 x flat head screw, flat washer, and wing nut or star knob (see **Figure 104**). Congratulations! Your featherboard is complete.



**Figure 104.** Assembling miter slot featherboard components.

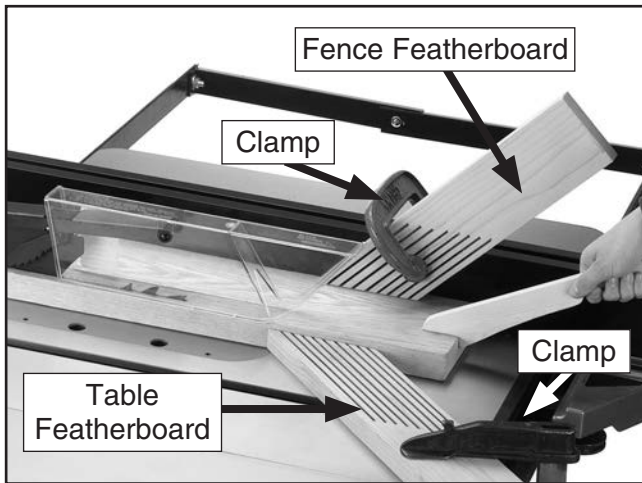
**Tip:** The length of the flat head screw depends on the thickness of the featherboard—though  $1\frac{1}{2}$ " to 2" lengths usually work.

Now, proceed to **Mounting Featherboard in Miter Slot** on **Page 58**.



## Mounting Featherboards w/Clamps

1. Lower saw blade, then adjust fence to desired width and secure it.
2. Place workpiece against fence, making sure it is 1" in front of the blade.
3. Place featherboard on table away from blade so all fingers point forward and contact workpiece (see **Figure 105**).

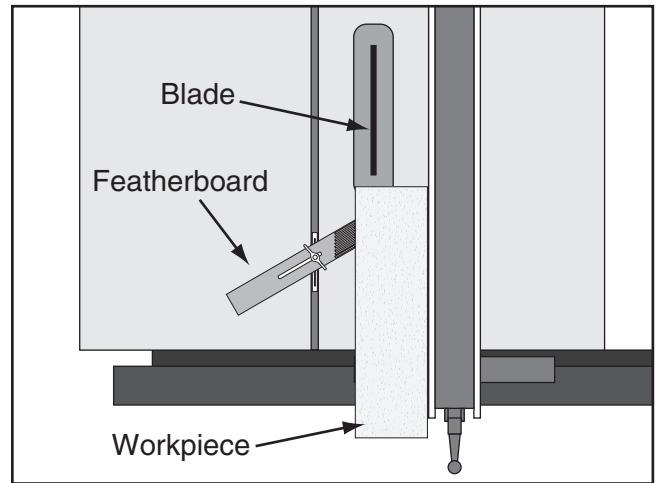


**Figure 105.** Example of featherboards secured with clamps.

4. Secure featherboard to table with clamp.
5. Check featherboard by pushing it with your thumb to ensure it is secure.  
—If the featherboard moves, tighten the clamp more.
6. Mount second featherboard to fence with another clamp (see **Figure 105**), then repeat **Step 5** to ensure it is secure.

## Mounting Featherboard in Miter Slot

1. Lower saw blade, then adjust fence to desired width and secure it.
2. Place workpiece evenly against fence, making sure it is 1" in front of blade.
3. Slide featherboard miter bar into miter slot, making sure fingers slant toward blade, as shown in **Figure 106**.



**Figure 106.** Featherboard installed in miter slot and supporting workpiece for ripping cut.

4. Position fingered edge of featherboard against edge of workpiece, so that all fingers contact workpiece. Slide featherboard toward blade until first finger is nearly even with end of workpiece, which should be 1" away from blade.
5. Double check workpiece and featherboard to ensure they are properly positioned as described in **Step 4**. Then secure featherboard to table. Check featherboard by hand to make sure it is tight.

**Note:** *The featherboard should be placed firmly enough against the workpiece to keep it against the fence but not so tight that it is difficult to feed the workpiece.*



# Push Sticks

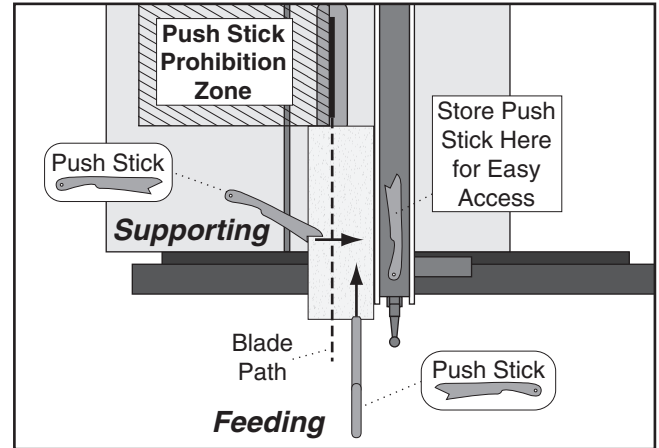
When used correctly, push sticks reduce the risk of injury by keeping hands away from the blade while cutting. In the event of an accident, a push stick can also absorb damage that would have otherwise happened to hands or fingers.

## Using a Push Stick

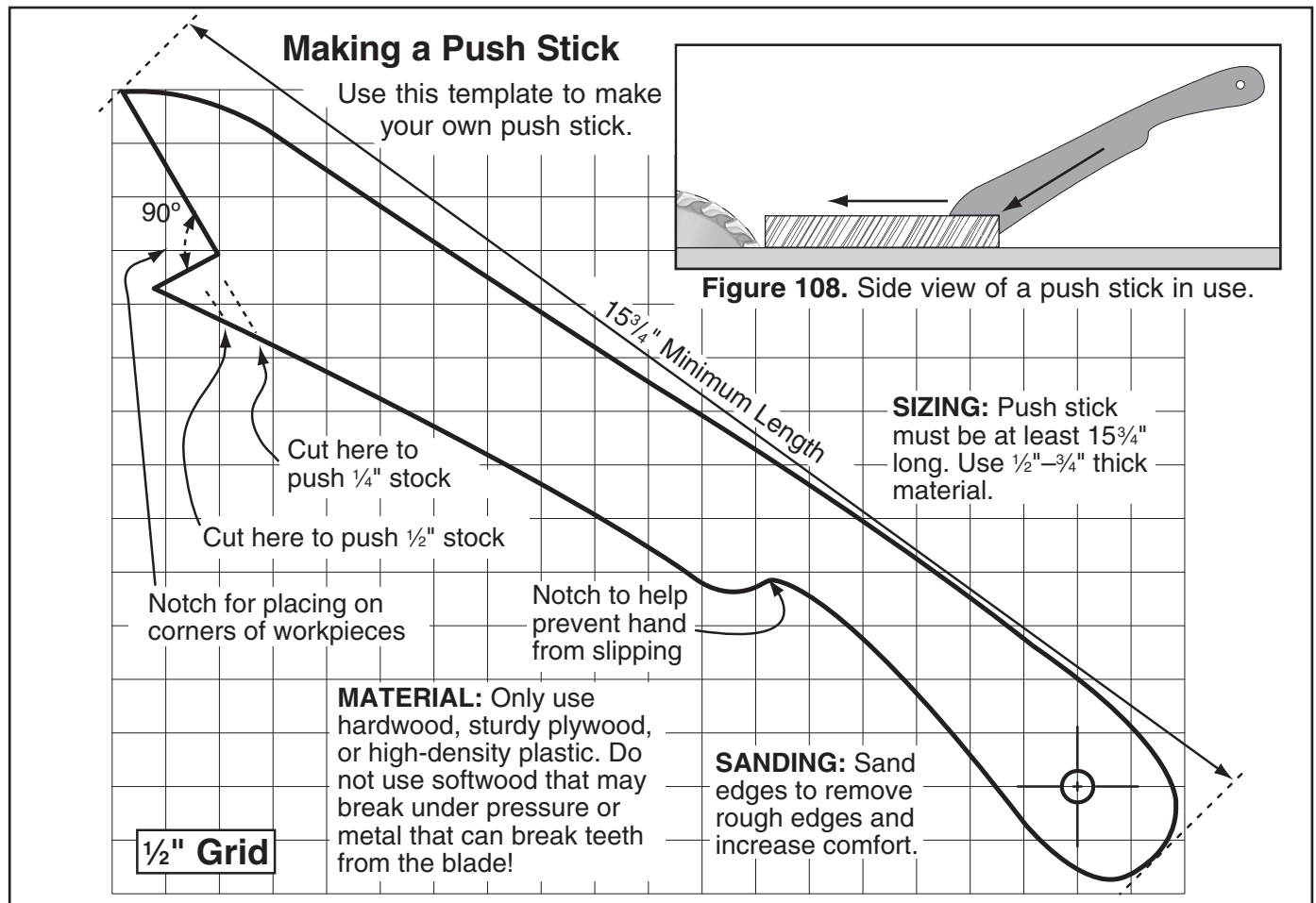
Use push sticks whenever your hands will get within 12" of the blade. To maintain control when cutting large workpieces, start the cut by feeding with your hands then use push sticks to finish the cut, so your hands are not on the end of the workpiece as it passes through the blade.

**Feeding:** Place the notched end of the push stick against the end of the workpiece (see inset **Figure** below), and move the workpiece into the blade with steady downward and forward pressure.

**Supporting:** A second push stick can be used to keep the workpiece firmly against the fence while cutting. When using a push stick in this manner, only apply pressure before the blade; otherwise, pushing the workpiece against or behind the blade will increase the risk of kickback (see "Push Stick Prohibition Zone" in the **Figure** below).



**Figure 107.** Using push sticks to rip narrow stock.



**Figure 108.** Side view of a push stick in use.

**Figure 109.** Template for a basic shop-made push stick (not shown at actual size).



# Push Blocks

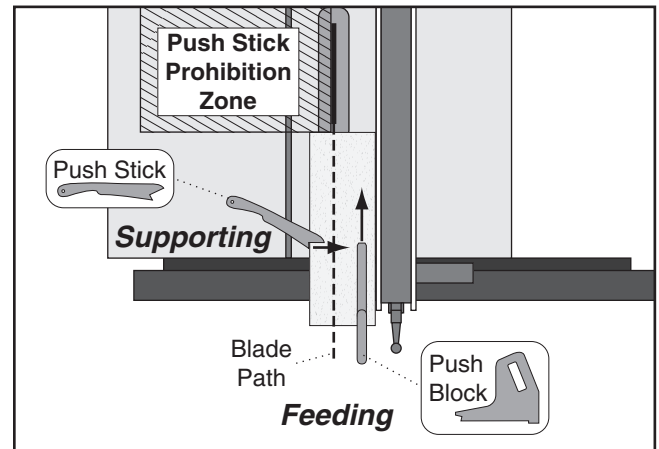
When used correctly, a push block reduces the risk of injury by keeping hands away from the blade while cutting. In the event of an accident, a push block often takes the damage that would have otherwise happened to hands or fingers.

## Using a Push Block

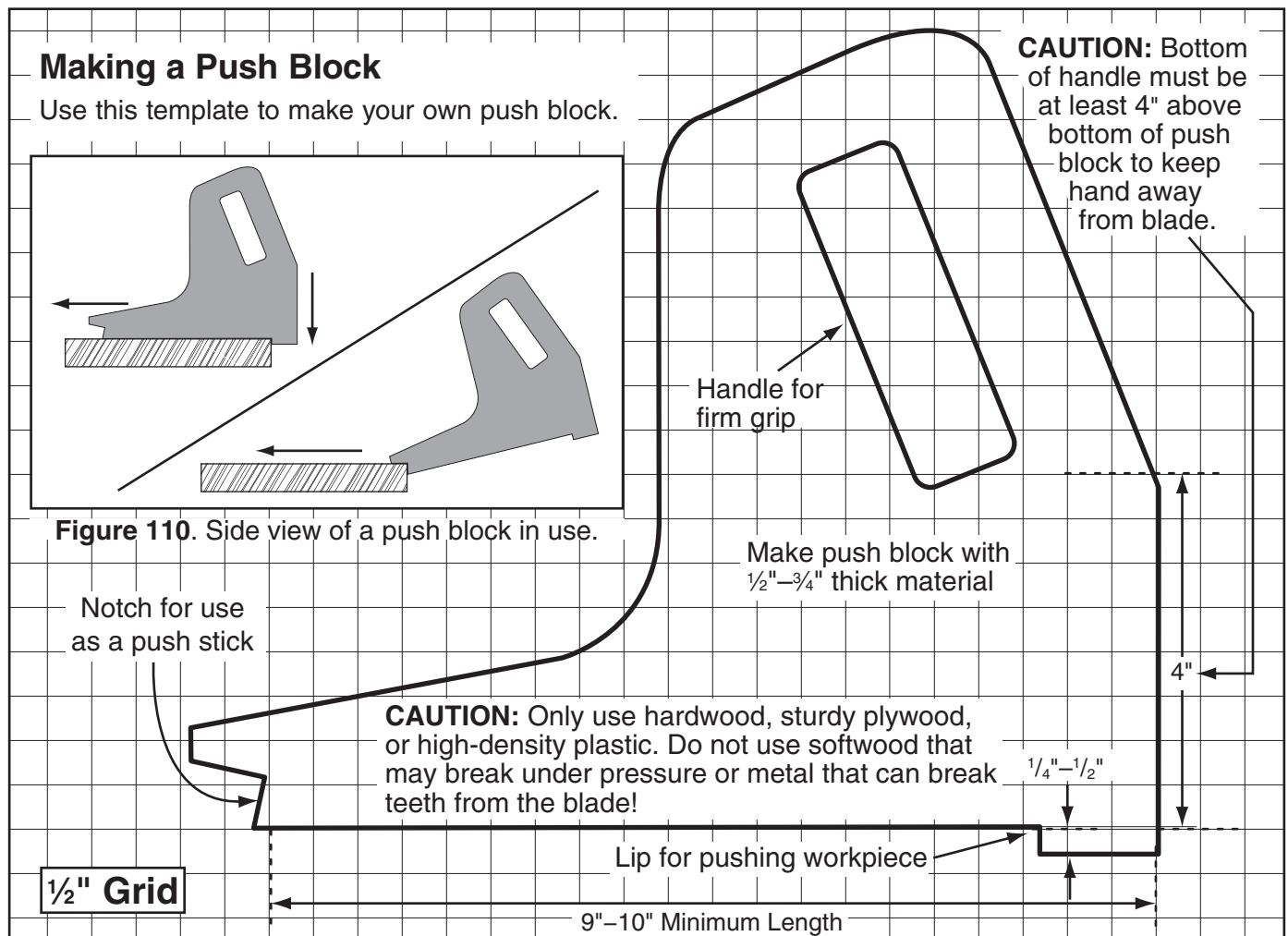
A push block can be used in place of or in addition to a push stick for feeding workpieces into the blade. Due to their design, push blocks allow the operator to apply firm downward pressure on the workpiece that could not otherwise be achieved with a push stick.

The push block design on this page can be used in two different ways (see inset **Figure** below). Typically, the bottom of the push block is used until the end of the workpiece reaches the blade.

The notched end of the push block is then used to push the workpiece the rest of the way through the cut, keeping the operator's hands at a safe distance from the blade. A push stick is often used at the same time in the other hand to support the workpiece during the cut (see "Using a Push Stick" on previous page).



**Figure 111.** Using a push block and push stick to make a rip cut.



**Figure 112.** Template for a shop-made push block (shown at 50% of full size).



# Zero-Clearance Insert

A zero-clearance insert can be made for the saw in about 30 minutes, and must be made of  $\frac{3}{4}$ " furniture quality plywood or hardwood. (We recommend making at least 6–12 while you are going through the process, so you have plenty on hand for varying blade widths, heights, or angles.)

A zero-clearance insert is required if you want to install a dado blade. When a dado blade is installed, the scoring blade and splitter/riving knife are removed—as neither will properly perform their intended function.

If you plan to use a standard blade with a zero-clearance insert, additional modifications will need to be made in order to install the scoring blade and splitter/riving knife.

## ⚠️ WARNING

If you must use this saw to cut the dimensions of the zero-clearance insert you will fabricate in these instructions, make sure you **DO NOT** make any cuts while the included table insert is removed. **THIS IS DANGEROUS.** You must re-install the table insert, reassemble all saw components, and remove all tools before cutting.

Items Needed	Qty
Table Saw .....	1
Drill Press .....	1
Sander .....	1
Drill Bits $\frac{7}{32}$ " and $\frac{13}{32}$ " .....	1 Each
Plywood/Hardwood Piece 14" x $\frac{11}{16}$ " x $\frac{3}{4}$ " .....	1
Bandsaw or Jigsaw (Optional) .....	1
Clamp (Optional) .....	1

### To make a zero-clearance table insert:

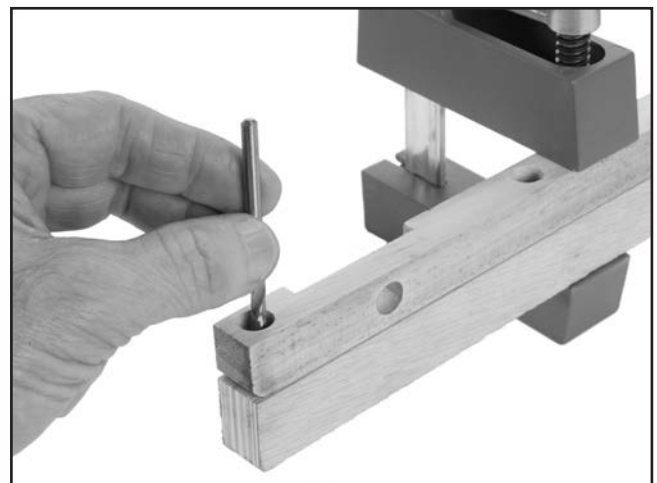
1. DISCONNECT MACHINE FROM POWER!
2. Lower main blade all the way, remove blade guard, splitter/riving knife, and scoring blade. After removing scoring blade, reinstall and tighten scoring blade flanges and arbor nut.

3. Remove main blade and spacer block behind it (see **Figure 113**).



**Figure 113.** Original table insert and all necessary components removed.

4. Remove table insert installed on saw.
5. Cut new table insert to exact length of included table insert and  $\frac{11}{16}$ " wide.
6. Use included table insert as template, as shown in **Figure 114**, to mark mounting holes on new table insert. (Clamping pieces together while you do this will allow you to ensure hole spacing is exact.)

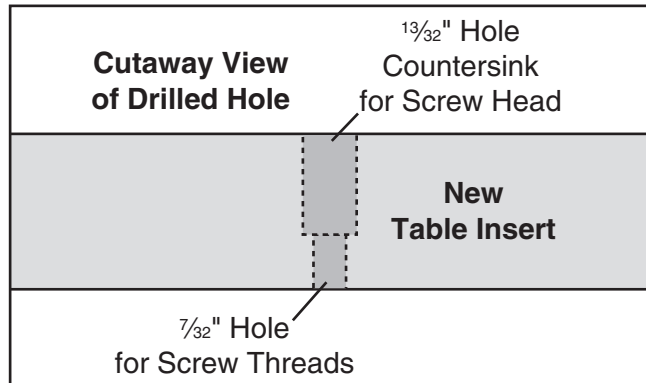


**Figure 114.** Marking location for mounting holes in new insert.

7. Use  $\frac{7}{32}$ " drill bit to drill holes completely through new table insert.
8. Install  $\frac{13}{32}$ " drill bit and use included table insert as guide to set depth stop on your drill press to countersink holes.



- Countersink holes you drilled in **Step 7** (see **Figure 115**), so heads of mounting screws can be recessed into table insert when installed.



**Figure 115.** Countersinking mounting holes.

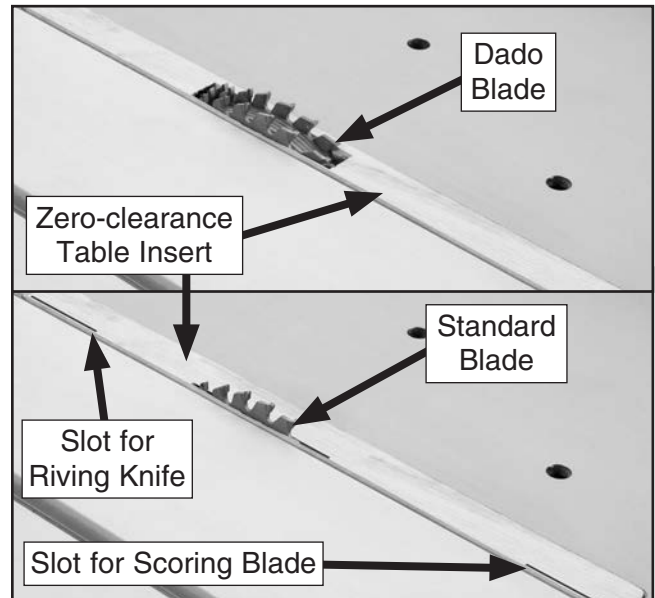
- Install blade you will use to cut insert, making sure blade flange is used on front of blade behind arbor nut, then lower blade fully.
- Test fit new table insert in table, then sand corners or trim ends as necessary to get a precise fit.
- Mount new table insert into table and check to make sure that it is flush with top of table. If necessary, remove insert and sand top of it down until it will mount up flush with table top (see **Figure 116**).



**Figure 116.** New zero-clearance table insert installed to be cut with a dado blade.

- (This step only for standard blades.)* Use bandsaw or jigsaw to cut slots or notches that will allow riving blade to be installed with minimal open space around it. If you plan to use scoring knife, do the same for that blade. (We do not recommend using the scoring blade to cut the slot in the insert because the adjustment screw is inside the cabinet).

- Close cover over blade and move sliding table to center of saw.
- Connect saw to power, start motor, and slowly raise blade into zero-clearance table insert (see **Figure 117**) only as high as you intend to cut with insert.



**Figure 117.** Zero-clearance table inserts for dado and standard blades.

## Outfeed Table

One of the best accessories for improving the safety and ease of using a table saw is simply placing a large table (outfeed table) behind the saw to catch the workpiece.



**Figure 118.** Example of outfeed table.





# SECTION 6: ACCESSORIES

## ⚠ WARNING

Installing unapproved accessories may cause machine to malfunction, resulting in serious personal injury or machine damage. To reduce this risk, only install accessories recommended for this machine by Grizzly.

## NOTICE

Refer to our website or latest catalog for additional recommended accessories.

### 10" Main Saw Blade

#### H4753—10" x 5/8" 80T Laminate Veneer Blade

This blade works especially well for most sliding table saw applications and is manufactured for heavy-duty, industrial use.

#### T24417—10" x 5/8" 40T General Purpose Blade

#### T24427—10" x 5/8" 80T Plywood Saw Blade

#### T21382—Scoring Blade

Replacement scoring blade. Measures 80mm in diameter with 22mm arbor hole. Blade is a solid, one-piece wedge-type blade. Kerf width is controlled by changing the height of the exposed portion of the blade from the table.

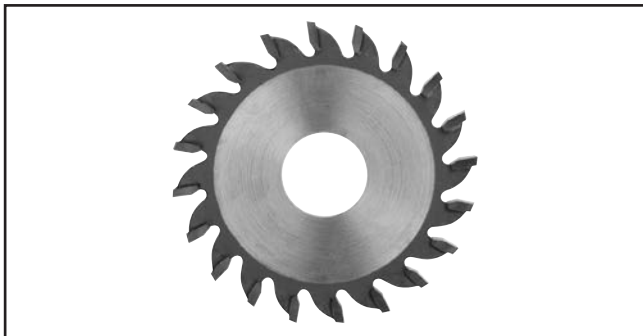


Figure 119. Model T21382 Scoring Blade.

#### G5562—SLIPIT® 1 Qt. Gel

#### G5563—SLIPIT® 12 Oz Spray

#### G2871—Boeshield® T-9 12 Oz Spray

#### G2870—Boeshield® T-9 4 Oz Spray

#### H3788—G96® Gun Treatment 12 Oz Spray



Figure 120. Recommended products for protecting unpainted cast-iron/steel parts on machinery.

#### T26419—NLGI#2 Syn-O-Gen Synthetic Grease

Formulated with 100% pure synthesized hydrocarbon basestocks that are compounded with special thickeners and additives to make Syn-O-Gen non-melt, tacky, and water resistant. Extremely low pour point, extremely high temperature oxidation, and thermal stability produce a grease that is unmatched in performance.



Figure 121. Model T26419 Syn-O-Gen Synthetic Grease.

**order online at [www.grizzly.com](http://www.grizzly.com) or call 1-800-523-4777**



- H2499—Small Half-Mask Respirator**
- H3631—Medium Half-Mask Respirator**
- H3632—Large Half-Mask Respirator**
- H3635—Cartridge Filter Pair P100**

Wood dust has been linked to nasal cancer and severe respiratory illnesses. If you work around dust every day, a half-mask respirator can be a lifesaver. Also compatible with safety glasses!



**Figure 122.** Half-mask respirator with disposable cartridge filters.

- H4978—Deluxe Earmuffs - 27dB**
- H4979—Twin Cup Hearing Protector - 29dB**
- T31622—Silicon Plugs, 3-Pk. - 20dB**

Protect yourself comfortably with a pair of cushioned earmuffs or moldable ear plugs. Especially important if you or employees operate for hours at a time.



**Figure 123.** Hearing protection.

**G0944—1½ HP Wall-Mount Dust Collector**  
 With an airflow capacity of 1250 CFM and a canister filter with a 1-micron filtration rating, this is the beast you need for all your small shop dust-capturing needs. The easy-to-hang French cleat-style mount makes hanging this unit quick, and clears up your floor space allowing for more room in a small shop.



**Figure 124.** Model G0944 1½ HP Wall-Mount Dust Collector with Canister Filter.

**order online at [www.grizzly.com](http://www.grizzly.com) or call 1-800-523-4777**



### H8029—5-Piece Safety Kit

This kit has four essential jigs. Includes two push blocks, push stick, featherboard, and combination saw and router gauge. Featherboard fits  $\frac{3}{8}$ " x  $\frac{3}{4}$ " miter slots. Made of high-visibility yellow plastic.



Figure 125. Model H8029 5-Piece Safety Kit.

### H4758 & H4759—Blade Stiffeners

For smoother, quieter cuts, a single FORREST Dampener-Stiffener is highly recommended for all applications. Made from top-quality saw steel and precision ground to within 0.001" of side runout. Mount one stiffener against the outside of the blade.



Figure 126. Models H4758 & H4759 Blade Stiffeners for 10" blades.

D4206—Clear Flexible Hose 4" x 10'

D4256—45° Elbow 4"

D4216—Black Flexible Hose 4" x 10'

W1034—Heavy-Duty Clear Flex Hose 4" x 10'

D2107—Hose Hanger 4 $\frac{1}{4}$ "

W1015—Y-Fitting 4" x 4" x 4"

W1017—90° Elbow 4"

W1019—Hose Coupler (Splice) 4"

W1317—Wire Hose Clamp 4"

W1007—Plastic Blast Gate 4"

W1053—Anti-Static Grounding Kit

Hand-picked selection of commonly used dust collection components for 4" dust ports.



Figure 127. Recommended dust collection accessories.

**order online at [www.grizzly.com](http://www.grizzly.com) or call 1-800-523-4777**

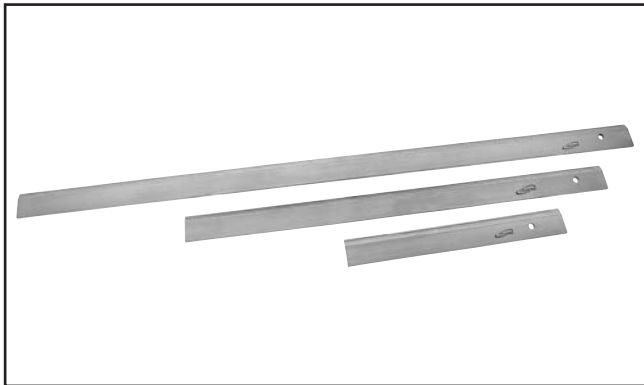


**T21578—12" Bevel Straight Edge w/ Scale**

**T21579—24" Bevel Straight Edge w/ Scale**

**T21580—36" Bevel Straight Edge w/ Scale**

These Bevel Straight Edges are made from hardened steel and feature a satin chrome finish and are ground and lapped for straightness and parallelism. Each straightedge offers true right angles for all edges, along with a beveled edge with scale in US standard. Accuracy of 0.001", and a resolution of 1/64".



**Figure 128.** Models T21578, T21579, and T21580 straightedge.

**D2271—Roller Table**

Use these versatile roller tables wherever you need extra workpiece support. Features all-steel welded construction and measures 19" x 65" long. Comes with 9 ball bearing rollers and has four independently adjustable legs for any leveling requirement. Adjustable in height from 26 3/8" to 44 1/8". Approximate shipping weight: 62 lbs. 1000 Lb. Capacity!



**Figure 129.** Model D2271 Roller Table.

**D2058A—Super Heavy-Duty Mobile Base**

This patented, super heavy-duty mobile machine base is the strongest mobile base on the market. 18" x 24 1/2" minimum and adjusts to 28 1/2" x 33 1/2" maximum. 1200 lb. capacity. This base is extremely stable with outrigger type supports and a four wheel system. Weighs 38 lbs.



**Figure 130.** Model D2058A Mobile Base (should not be used with hardwired Model G0623X3).

**Basic Eye Protection**

**T20501—Face Shield Crown Protector 4"**

**T20502—Face Shield Crown Protector 7"**

**T20503—Face Shield Window**

**T20451—"Kirova" Clear Safety Glasses**

**T20456—DAKURA Safety Glasses, Black/Clear**

**T28175—S3960HS Stealth Safety Glasses**



**Figure 131.** Eye protection assortment.

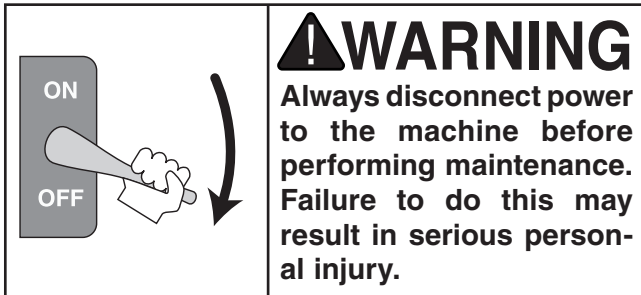
**order online at [www.grizzly.com](http://www.grizzly.com) or call 1-800-523-4777**



# SECTION 7: MAINTENANCE

---

---



## Schedule

---

---

The frequency of maintenance necessary for any machine will always depend on the operating conditions and environment. The schedule below is a basic guideline for keeping your machine in proper operating condition. Always repair any adverse conditions immediately upon discovery.

### Daily (Ongoing)

- Loose mounting bolts.
- Worn or damaged saw blades.
- Worn or damaged switches or wires.
- Any other unsafe condition.

### Weekly

- Clean sliding table surface and grooves.
- Lubricate the sliding table ways (**Page 68**).
- Clean the cast iron saw table.
- Clean the sliding table roller guideways.
- Clean the rip fence.
- Clean the rip fence bracket and rail.

### Monthly

- Clean/vacuum dust buildup from inside cabinet and off motor.
- Check V-belt tension, damage, or wear.

### Every 6–12 Months

- Lubricate the trunnions (**Page 68**).
- Lubricate the elevation and tilt leadscrews (**Page 68**).

**Note:** To ensure optimum power transmission from the motor to the blades, the V-belts must be in good condition (free from cracks, fraying and wear) and operate under proper tension.

## Cleaning

---

---

Cleaning the Model G0623X/G0623X3 is relatively easy. Vacuum excess wood chips and sawdust from the table saw and inside the cabinet. Wipe off the remaining dust with a dry cloth.

Use compressed air (make sure to wear safety glasses and a respirator when doing this) to blow dust from between the two sections of the sliding table. If any resin has built up, use a resin dissolving cleaner to remove it. Treat all unpainted cast iron and steel with a non-staining lubricant after cleaning.

## Unpainted Cast Iron

---

---

Protect the unpainted cast-iron surfaces on the table by wiping the table clean after every use—this ensures moisture from wood dust does not remain on bare metal surfaces. DO NOT clean cast iron with water or it will rust!

Keep tables rust-free with regular applications of products like G96® Gun Treatment, SLIPIT®, or Boeshield® T-9 (see **Page 63** for more details).



# Lubrication

**Bearings:** The bearings are sealed and pre-lubricated; they require no lubrication.

**Trunnions:** Use multi-purpose grease in the trunnion grooves (**Figure 133**) every 6–12 months, depending on the frequency of use. To grease the blade height trunnion, move the blade height all the way down and smear a dab of grease into the trunnion groove, behind the plate shown in **Figure 133**, then move the blade up all the way, then down all the way to spread the grease.

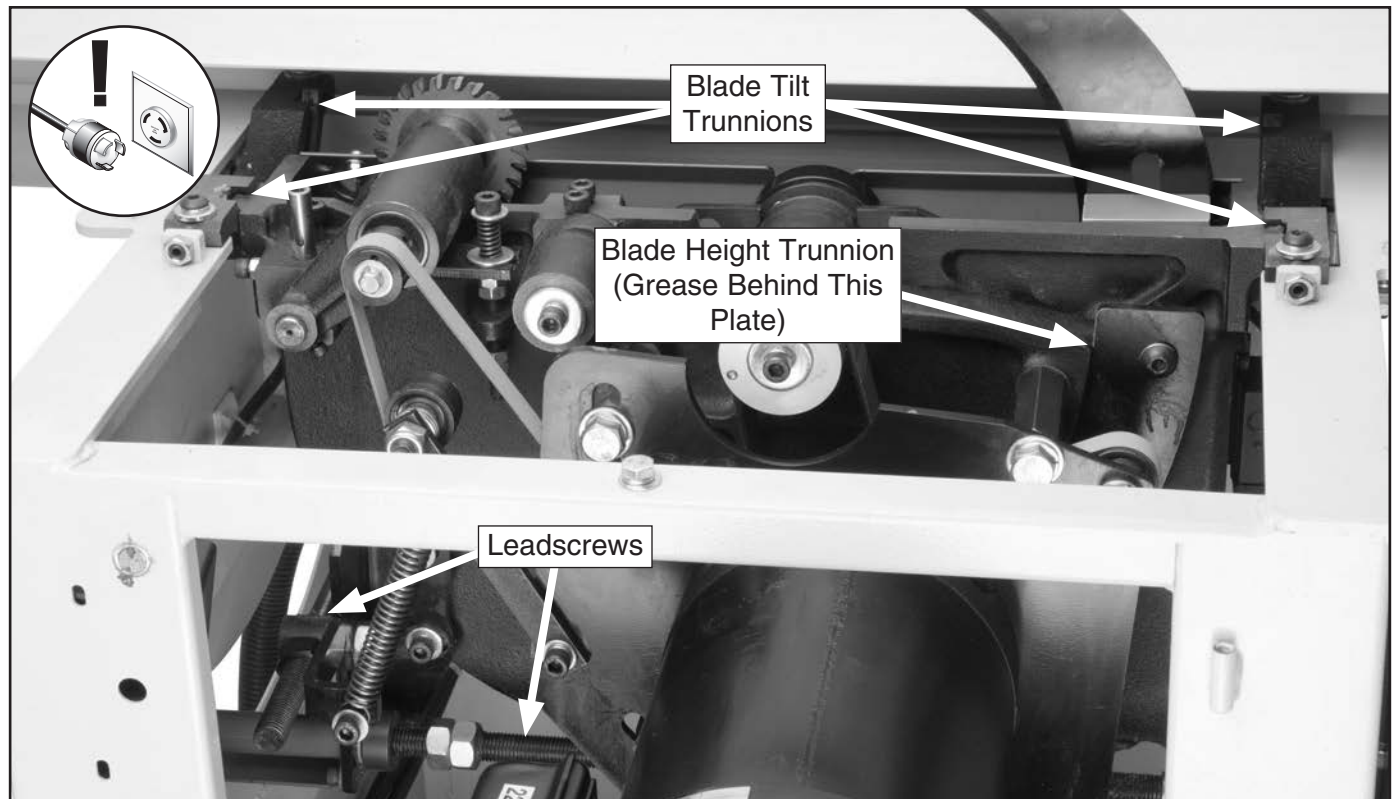
To grease the blade tilt trunnions, move the sliding table out of the way and open the blade guard. Tilt the blade to 90°. From the front of the saw, smear a dab of grease in the front of the trunnion grooves on both sides. Now, tilt the blade to 45° and reach inside the cabinet and smear a dab of grease into the back of the trunnion grooves on both sides. Tilt the blade back and forth to distribute the grease evenly.

**Leadscrews:** Use multi-purpose grease on the leadscrews (**Figure 133**) every 6-12 months, at the same time you lubricate the trunnions. Wipe the leadscrews clean with a dry rag and brush a light coat of new grease on them with a clean, dry brush. Only grease the area of the leadscrew between the stop nuts. Move the blade height and tilt back and forth to distribute the grease evenly.

**Sliding Table Ways & Rip Fence Rail:** Wipe on a light machine oil (such as Boeshield shown on **Page 63**) down the entire length of the sliding table steel rods (**Figure 132**) and rip fence rail.



**Figure 132.** Sliding table ways.



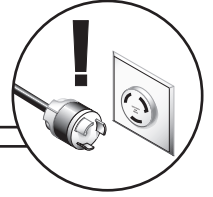
**Figure 133.** Lubrication locations (table removed for clarity).



# SECTION 8: SERVICE

Review the troubleshooting procedures in this section if a problem develops with your machine. If you need replacement parts or additional help with a procedure, call our Technical Support. **Note:** *Please gather the serial number and manufacture date of your machine before calling.*

## Troubleshooting



### Motor & Electrical

Symptom	Possible Cause	Possible Solution
Machine does not start or a breaker trips.	<ol style="list-style-type: none"> <li>1. Stop push-button is engaged/faulty.</li> <li>2. Power supply switched OFF or is at fault.</li> <li>3. Motor connection wired incorrectly.</li> <li>4. Thermal overload relay has tripped.</li> <li>5. Wall fuse/circuit breaker is blown/tripped.</li> <li>6. Contactor not getting energized/has burnt contacts.</li> <li>7. Wiring is open/has high resistance.</li> <li>8. Motor ON button or ON/OFF switch is at fault.</li> <li>9. Motor is at fault.</li> </ol>	<ol style="list-style-type: none"> <li>1. Rotate clockwise slightly until it pops out/replace it.</li> <li>2. Ensure power supply is switched on; ensure power supply has the correct voltage.</li> <li>3. Correct motor wiring connections.</li> <li>4. Wait for it to cool down, then it will reset automatically. If necessary, disconnect power and reset manually by pushing reset button inside switch.</li> <li>5. Ensure circuit size is suitable for this machine; replace weak breaker.</li> <li>6. Test for power on all legs and contactor operation. Replace unit if faulty.</li> <li>7. Check for broken wires or disconnected/corroded connections, and repair/replace as necessary.</li> <li>8. Replace faulty ON button or ON/OFF switch.</li> <li>9. Test/repair/replace.</li> </ol>
Machine stalls or is underpowered.	<ol style="list-style-type: none"> <li>1. Feed rate/cutting speed too fast for task.</li> <li>2. Workpiece material is not suitable for this machine.</li> <li>3. Belt(s) slipping.</li> <li>4. Motor connection is wired incorrectly.</li> <li>5. Motor bearings are at fault.</li> <li>6. Start delay module is at fault.</li> <li>7. Motor is at fault.</li> </ol>	<ol style="list-style-type: none"> <li>1. Decrease feed rate/cutting speed.</li> <li>2. Only cut wood products; make sure moisture content is below 20% and there are no foreign materials in the workpiece.</li> <li>3. Replace bad belt(s), align pulleys, and re-tension.</li> <li>4. Correct motor wiring connections.</li> <li>5. Test by rotating shaft; rotational grinding/loose shaft requires bearing replacement.</li> <li>6. Adjust to correct delay; replace module.</li> <li>7. Test/repair/replace.</li> </ol>



Symptom	Possible Cause	Possible Solution
Machine has vibration or noisy operation.	<ol style="list-style-type: none"> <li>1. Motor or component is loose.</li> <li>2. Blade is at fault.</li> <li>3. Belt(s) worn or loose.</li> <li>4. Pulley is loose.</li> <li>5. Motor mount loose/broken.</li> <li>6. Machine is incorrectly mounted or sits unevenly.</li> <li>7. Arbor pulley is loose.</li> <li>8. Motor fan is rubbing on fan cover.</li> <li>9. Arbor bearings are at fault.</li> <li>10. Motor bearings are at fault.</li> </ol>	<ol style="list-style-type: none"> <li>1. Inspect/replace stripped or damaged bolts/nuts, and re-tighten with thread locking fluid.</li> <li>2. Replace warped, bent, or twisted blade; resharpen dull blade.</li> <li>3. Inspect/replace belts (refer to <b>Page 71</b>).</li> <li>4. Realign/replace shaft, pulley, setscrew, and key as required.</li> <li>5. Tighten/replace.</li> <li>6. Tighten/replace anchor studs in floor; relocate/shim machine.</li> <li>7. Retighten/replace arbor pulley with shaft and thread locking liquid.</li> <li>8. Replace dented fan cover; replace loose/damaged fan.</li> <li>9. Replace arbor housing bearings; replace arbor.</li> <li>10. Test by rotating shaft; rotational grinding/loose shaft requires bearing replacement.</li> </ol>
Main blade runs backwards (G0623X3 only).	<ol style="list-style-type: none"> <li>1. Two of the power wires are reversed (3-phase version only).</li> </ol>	<ol style="list-style-type: none"> <li>1. Exchange wires R &amp; T in the terminal box (3-phase version only).</li> </ol>

## Operation

Symptom	Possible Cause	Possible Solution
Workpiece has burned edges, binds, or kicks back.	<ol style="list-style-type: none"> <li>1. Sliding table is not parallel to blade.</li> <li>2. Riving knife is not aligned with the blade.</li> <li>3. Blade is warped.</li> </ol>	<ol style="list-style-type: none"> <li>1. Adjust sliding table parallel with the blade (<b>Page 73</b>).</li> <li>2. Adjust the riving knife to align it with the main blade.</li> <li>3. Replace the blade.</li> </ol>
Workpiece has chip out on the bottom edge.	<ol style="list-style-type: none"> <li>1. Scoring blade height is incorrect.</li> <li>2. Scoring blade is not aligned with the main blade.</li> <li>3. Scoring blade kerf does not match the main blade.</li> </ol>	<ol style="list-style-type: none"> <li>1. Adjust the height of the scoring blade.</li> <li>2. Align the scoring blade (<b>Page 44</b>).</li> <li>3. Adjust the scoring blade kerf (<b>Page 44</b>).</li> </ol>
Cuts are not square.	<ol style="list-style-type: none"> <li>1. Sliding table is not parallel to blade.</li> <li>2. Rip fence is not parallel to blade.</li> <li>3. Crosscut fence is not perpendicular to the blade.</li> </ol>	<ol style="list-style-type: none"> <li>1. Adjust the sliding table (<b>Page 74</b>).</li> <li>2. Adjust the rip fence parallel to blade.</li> <li>3. Adjust the crosscut fence perpendicular to the blade.</li> </ol>
Fence hits table top when sliding across table.	<ol style="list-style-type: none"> <li>1. Front rail is too low.</li> <li>2. Rip fence roller is too low.</li> </ol>	<ol style="list-style-type: none"> <li>1. Raise the front rail.</li> <li>2. Adjust the rip fence roller.</li> </ol>
Blade does not reach 90°, or blade does not reach 45°.	<ol style="list-style-type: none"> <li>2. Blade tilt stop bolts are out of adjustment.</li> </ol>	<ol style="list-style-type: none"> <li>2. Adjust the tilt stop bolts (<b>Page 72</b>).</li> </ol>
The rip fence scale is not accurate.	<ol style="list-style-type: none"> <li>1. The rip fence scale is out of calibration or was not set up correctly.</li> </ol>	<ol style="list-style-type: none"> <li>1. Adjust the rip fence scale so it is accurately calibrated with the blade.</li> </ol>
Handwheels for blade adjustments will not turn or are difficult to turn.	<ol style="list-style-type: none"> <li>1. Shipping braces still attached.</li> <li>2. Lock knob is tight.</li> <li>3. Gears caked with dust.</li> </ol>	<ol style="list-style-type: none"> <li>1. Remove shipping braces.</li> <li>2. Release the lock knob.</li> <li>3. Clean out dust and grease the gears.</li> </ol>



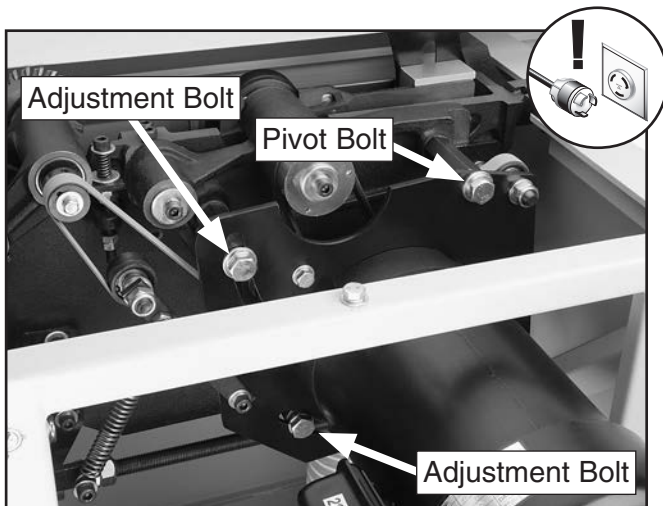


# Belt Replacement

## Main Belt Replacement

1. DISCONNECT MACHINE FROM POWER!
2. Tilt blade to 45° and lower it as far as it will go.
3. Remove motor cabinet door.
4. Loosen pivot bolt and two adjustment bolts (**Figure 134**).

**Note:** DO NOT loosen these bolts more than 1/2" or you run the risk of the motor mount bolts coming out of their holes, which will be difficult to thread back in.



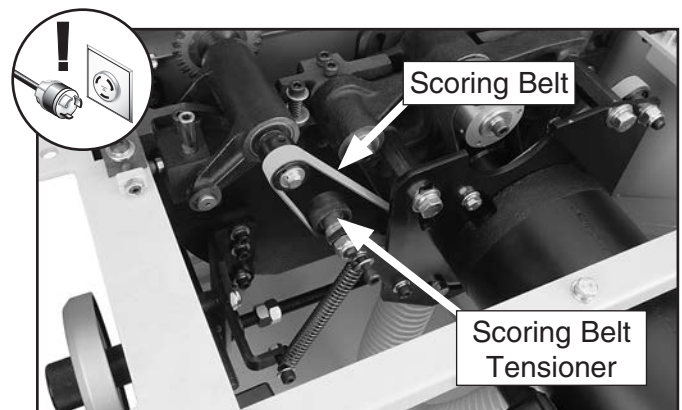
**Figure 134.** Main blade belt tension controls.

5. Push and hold motor all the way up to relieve tension on belt, remove belts from top pulley, and squeeze them between lower pulley and casting.
6. Fit new belts onto pulleys in same manner that you removed old belts.
7. Push down on motor with one hand, and tighten adjustment and pivot bolts with the other hand or have someone help you. The belts should be tight enough that they only deflect approximately 1/4" when pushed in the center with your thumb or index finger.
8. Replace motor cabinet door.

## Scoring Belt Replacement

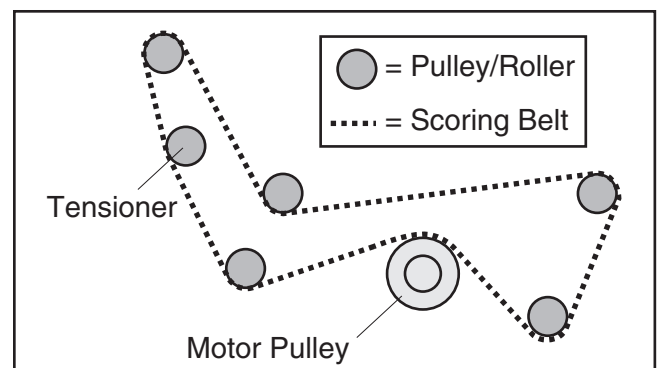
1. DISCONNECT MACHINE FROM POWER!
2. Tilt blade to 45° and lower it as far as it will go.
3. Remove motor cabinet door.
4. Pull tensioner away from scoring belt (**Figure 135**) to relieve belt tension and remove scoring belt from the pulleys.

**Note:** Turn the belt sideways to squeeze the flat part through the small gap between the bottom pulley and the casting.



**Figure 135.** Replacing the scoring motor belt.

5. Put the scoring belt on pulleys as shown in **Figure 136**, and push tensioner against scoring belt to take up any slack.



**Figure 136.** Scoring belt installation configuration.

6. Replace motor cabinet door.



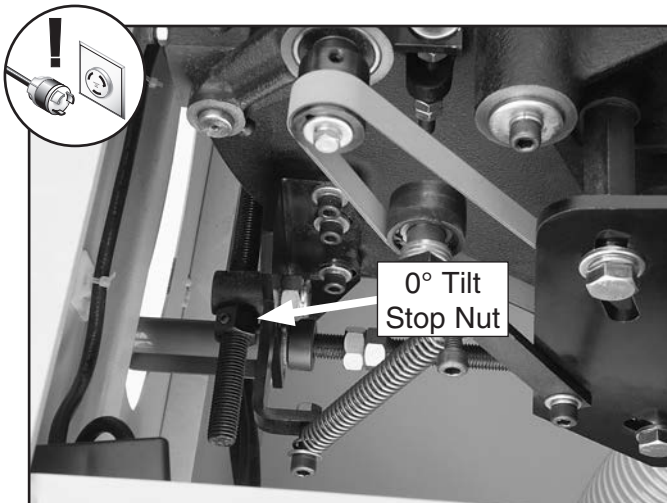
# Blade Tilt Calibration

The blade tilt is calibrated at the factory, but can be recalibrated if it changes during the life of the machine. The 0° stop positions the blade square with the table.

## 0° Stop

1. DISCONNECT MACHINE FROM POWER!
2. Move blade tilt to 0° according to gauge, and raise main blade as far as it will go.
3. Use a machinist's square to check if blade is square to table.

—If the blade is not square to the table, loosen the two set screws that secure the 0° tilt stop nut shown in **Figure 137**.



**Figure 137.** Blade tilt stop nut (0°).

4. Adjust stop nut and recheck blade tilt as many times as necessary until blade is square to table.
5. Tighten two set screws in stop nut.
6. Check blade tilt pointer mechanism to ensure that it points to 0°.

—If the blade tilt pointer shows an incorrect tilt, adjust it by loosening the cap screws, rotating the pointer until it points to 0°, then tightening the cap screws.

## 45° Stop

1. DISCONNECT MACHINE FROM POWER!
2. Adjust blade angle until you hit the 45° positive stop and check blade angle with a 45° square.

—If the blade is not 45° to the table, loosen the two set screws that secure the 45° tilt stop nut shown in **Figure 138**. (This nut can also be accessed from the front of the saw by moving the sliding table all the way forward.)



**Figure 138.** Blade tilt stop nut (45°).

3. Adjust stop nut and recheck blade tilt as many times as necessary until blade is 45° to table.
4. Tighten two set screws in stop nut.



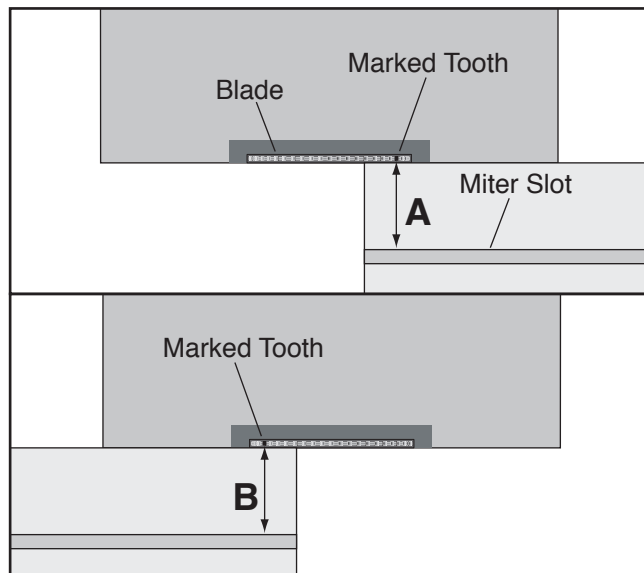
# Sliding Table Parallel Adjustment

The table is calibrated at the factory, but can be adjusted slightly if it is not parallel to the blade.

Tools Needed:	Qty
Felt Tip Pen.....	1
90° Square .....	1
Precise Measuring Tool.....	1
Wrench 17mm .....	1
Hex Wrench 5mm.....	1

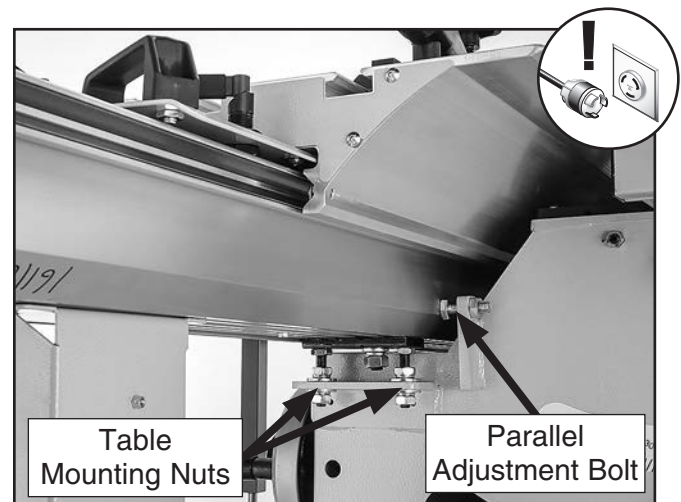
**To adjust the sliding table parallel with the main blade:**

1. DISCONNECT MACHINE FROM POWER!
2. Move blade tilt to 0° (blade 90° to table), and raise main blade up to maximum height.
3. Mark one blade tooth with a felt-tip pen. This will be your reference point when taking measuring points, so you take them in the same location each time.
4. Move sliding table all the way back, and measure distance "A" in **Figure 139**, between marked tooth and edge of miter slot.



**Figure 139.** Measuring distance between table and blade.

5. Rotate blade 180°, move sliding table all the way forward, and measure distance between "B" in **Figure 139**.
6. Note difference between the two positions.
  - If the gap is the same on both sides or the difference is 0.004" or less, no adjustments to the table parallelism need to be made.
  - If the difference is greater than 0.004", then the sliding table parallelism must be adjusted. Proceed to **Step 7**.
7. Loosen sliding table mounting nuts (see **Figure 140**) at both mounting locations.



**Figure 140.** Table parallelism adjustment controls.

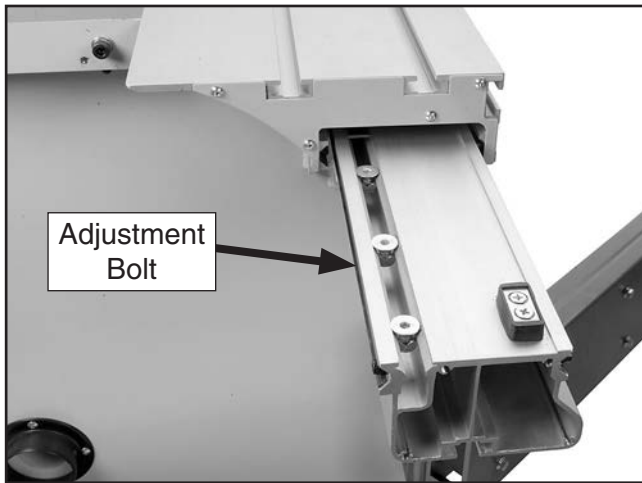
8. At side of the table that needs to move, loosen hex nut on parallel adjustment bolt.
9. Slowly rotate parallel adjustment bolt (see **Figure 140**) as necessary to move table. If you move adjustment bolt away from table, push table against bolt before proceeding.
10. Tighten hex nut on parallel adjustment bolt to secure it in place, then tighten table mounting nuts. Repeat **Steps 4–6** as necessary until sliding table is parallel with blade.



# Sliding Table Adjustment

---

The sliding table features an adjustment bar with bolts that control how easily the sliding table moves across the base (see **Figure 141**). These adjustment bolts are factory set. They can only be accessed by removing the end covers from both ends of the sliding table base and sliding the plastic plate out of the way.



**Figure 141.** Adjustment bolt access location.

If the adjustment bolts do require adjustments, turning them counterclockwise increases pressure against the steel rails. This reduces table movement slop, which increases accuracy, but makes it harder to slide the table.

Turning the adjustment bolts clockwise decreases the pressure against the steel rails. This increases table movement slop, which reduces accuracy, but makes it easier to slide the table.

Adjusting this part of the sliding table correctly is a matter of trial-and-error by making adjustments, moving the sliding table, then making additional adjustments. Ultimately, the table must move easily without any slop.



# Squaring Crosscut Fence to Blade

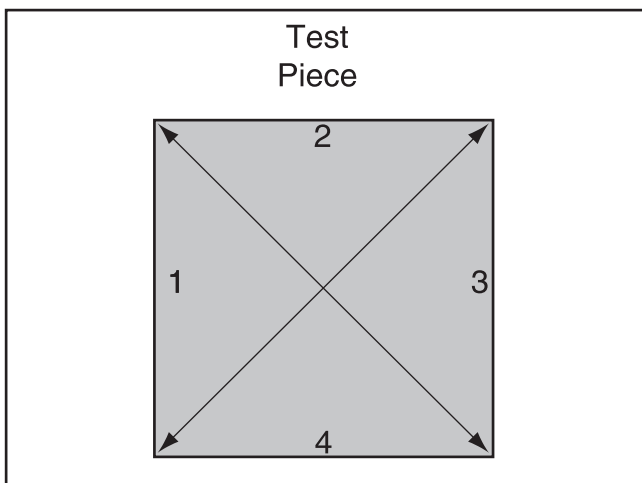
Squaring the crosscut fence to the blade ensures that cuts made with the crosscut fence will be square. This procedure can be done by using a piece of scrap plywood as a test piece and making five test cuts, then adjusting the fence as necessary.

## To square the crosscut fence with the blade:

1. Make sure blade is parallel with sliding table and that crosscut fence is resting against 90° stop bolt (see **Figure 143** for locations).
2. Prepare scrap test piece by cutting it to 32" x 32", then number all four sides of test piece.
3. Use crosscut fence to cut 1/2" off of each side of test piece, then cut side 1 again (make five cuts total).
4. Measure test piece diagonally from corner-to-corner as shown in **Figure 142**.

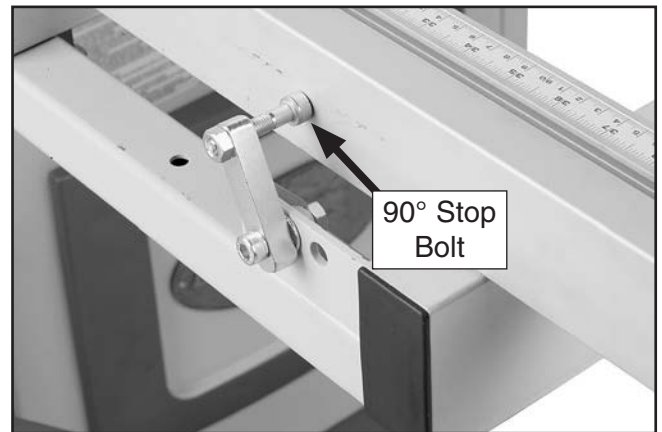
—If both measurements are not within 1/16", then the crosscut fence needs to be adjusted. Proceed to **Steps 5–8**.

—If both measurements are within 1/16" then no adjustments need to be made. You are finished with this procedure.



**Figure 142.** Fence adjustment test piece.

5. Loosen knob on crosscut fence to allow it to pivot (make sure 90° stop bolt remains against fence during adjustments).
6. Loosen hex nut on 90° stop bolt shown in **Figure 143**, and rotate 90° stop bolt to square crosscut fence.



**Figure 143.** Crosscut fence adjustment cam.

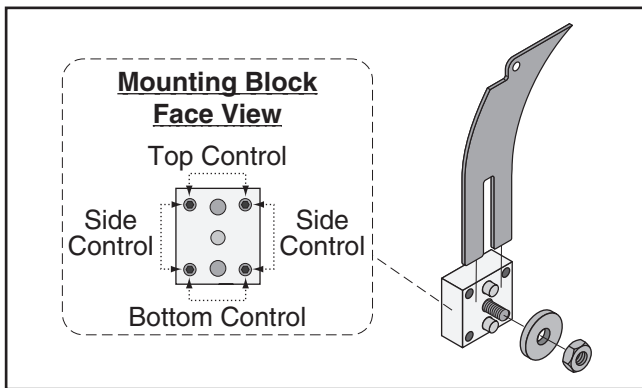
7. Tighten hex nut on 90° stop bolt, then tighten crosscut fence knob, making sure block is touching 90° stop bolt.
8. Repeat **Steps 3-4**.



# Splitter/Riving Knife Mounting Block

The splitter/riving knife must be aligned with the blade when installed. If the splitter/riving knife is not aligned with the blade, then the workpiece will be forced sideways during the cut, which will increase the risk of kickback.

The splitter/riving knife mounts to a block that can be repositioned to correctly align the splitter/riving knife to the blade. The mounting block adjusts by turning the set screws in each corner of the block. **Figure 144** shows the set screws associated with controlling the mounting block position. Have patience when adjusting the mounting block, because it requires trial-and-error to perform with accuracy.



**Figure 144.** Splitter/riving knife mounting block adjustment controls.

All adjustment and alignment positions for the splitter/riving knife are covered on **Page 40** in the subsection **Splitter/Riving Knife Installation & Removal**; the mounting block should not be adjusted unless you have been unable to mount the splitter/riving knife as instructed by these procedures.

Tools Needed	Qty
Straightedge .....	1
Wrench 17mm .....	1
Hex Wrench 4mm.....	1

## To adjust the splitter/riving knife mount block:

1. DISCONNECT MACHINE FROM POWER!
2. Raise blade all the way up, move sliding table to side, and open lower blade cover to gain access to splitter/riving knife mounting block.
3. Loosen lock nut that secures splitter/riving knife to mounting block, and remove splitter/riving knife.
4. Adjust each pair of set screws that controls direction required to move mounting block so splitter/riving knife can be aligned with blade. Make sure to move both set screws in even increments.
5. Reinstall splitter/riving knife and check alignment with blade. Repeat **Step 4** as necessary until splitter/riving knife is properly aligned to blade.  
  
**Note:** *If you discover that the splitter/riving knife is bent and cannot be properly aligned with the blade, it is possible to bend it into alignment, but make sure that the final result is precisely aligned so the risk of kickback is not increased. If the splitter/riving knife is bent, and you cannot easily bend it back into alignment, we recommend replacing it with a new one.*
6. Properly re-install splitter/riving knife as described on **Page 40**, close blade cover, and move sliding table back to center position.



# SECTION 9: WIRING

These pages are current at the time of printing. However, in the spirit of improvement, we may make changes to the electrical systems of future machines. Compare the manufacture date of your machine to the one stated in this manual, and study this section carefully.

If there are differences between your machine and what is shown in this section, call Technical Support at (570) 546-9663 for assistance BEFORE making any changes to the wiring on your machine. An updated wiring diagram may be available. **Note:** *Please gather the serial number and manufacture date of your machine before calling. This information can be found on the main machine label.*

## WARNING

### Wiring Safety Instructions

**SHOCK HAZARD.** Working on wiring that is connected to a power source is extremely dangerous. Touching electrified parts will result in personal injury including but not limited to severe burns, electrocution, or death. Disconnect the power from the machine before servicing electrical components!

**MODIFICATIONS.** Modifying the wiring beyond what is shown in the diagram may lead to unpredictable results, including serious injury or fire. This includes the installation of unapproved after-market parts.

**WIRE CONNECTIONS.** All connections must be tight to prevent wires from loosening during machine operation. Double-check all wires disconnected or connected during any wiring task to ensure tight connections.

**CIRCUIT REQUIREMENTS.** You MUST follow the requirements at the beginning of this manual when connecting your machine to a power source.

**WIRE/COMPONENT DAMAGE.** Damaged wires or components increase the risk of serious personal injury, fire, or machine damage. If you notice that any wires or components are damaged while performing a wiring task, replace those wires or components.

**MOTOR WIRING.** The motor wiring shown in these diagrams is current at the time of printing but may not match your machine. If you find this to be the case, use the wiring diagram inside the motor junction box.
















**CAPACITORS/INVERTERS.** Some capacitors and power inverters store an electrical charge for up to 10 minutes after being disconnected from the power source. To reduce the risk of being shocked, wait at least this long before working on capacitors.

**EXPERIENCING DIFFICULTIES.** If you are experiencing difficulties understanding the information included in this section, contact our Technical Support at (570) 546-9663.

#### NOTICE

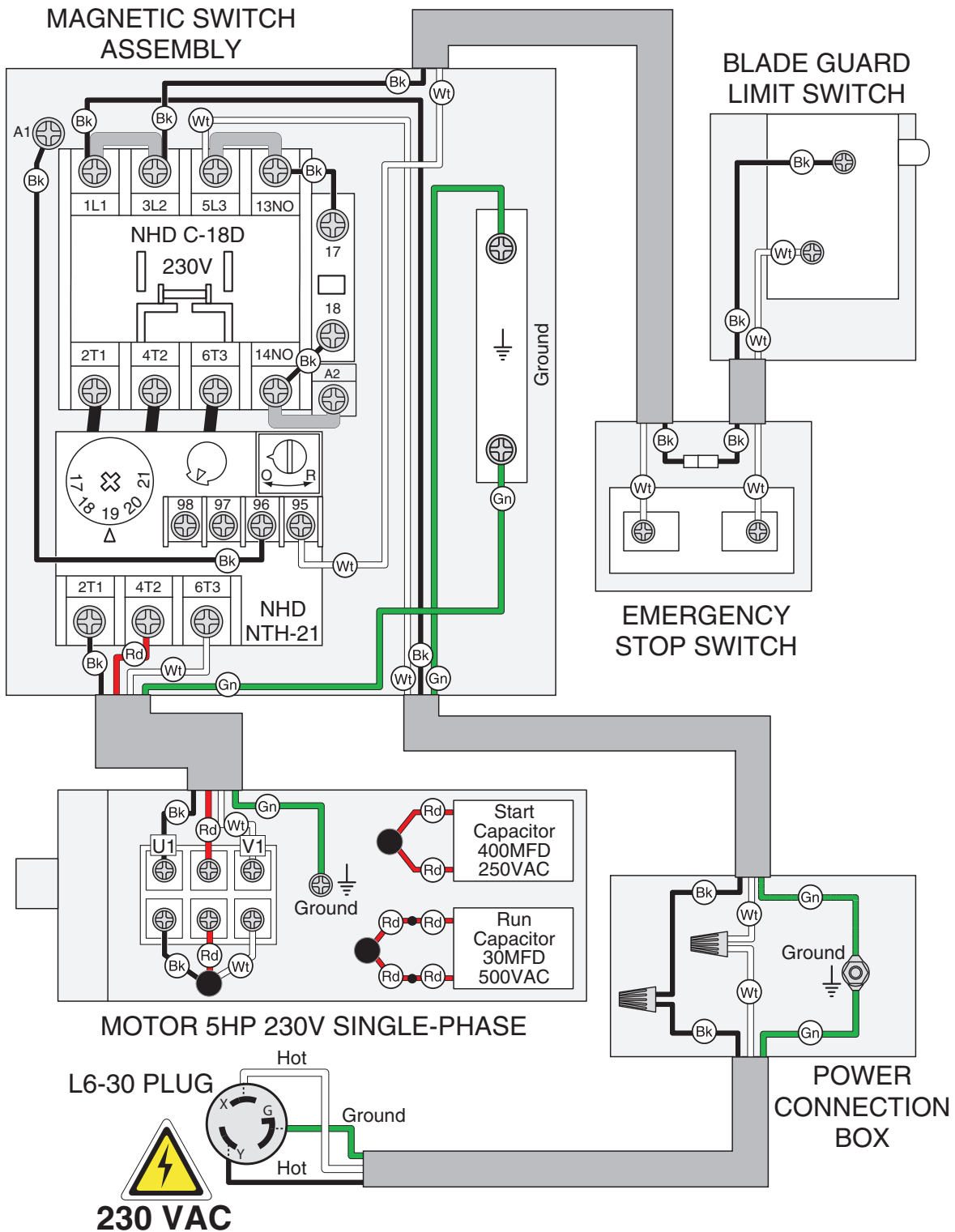
The photos and diagrams included in this section are best viewed in color. You can view these pages in color at [www.grizzly.com](http://www.grizzly.com).

#### COLOR KEY

BLACK 	BLUE 	YELLOW 	LIGHT BLUE 
WHITE 	BROWN 	YELLOW GREEN 	BLUE WHITE 
GREEN 	GRAY 	PURPLE 	TURQUOISE 
RED 	ORANGE 	PINK 	

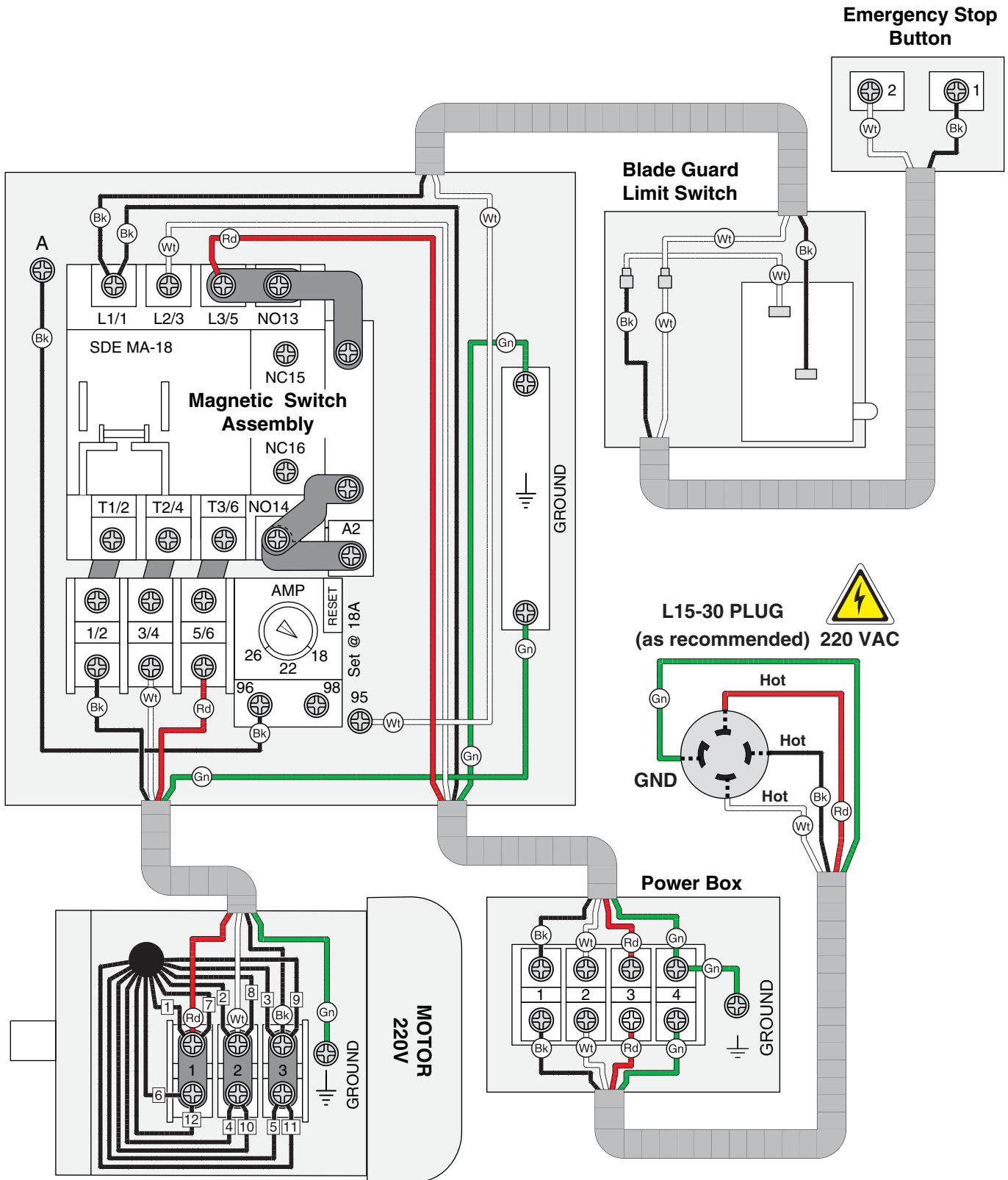


# G0623X Wiring Diagram

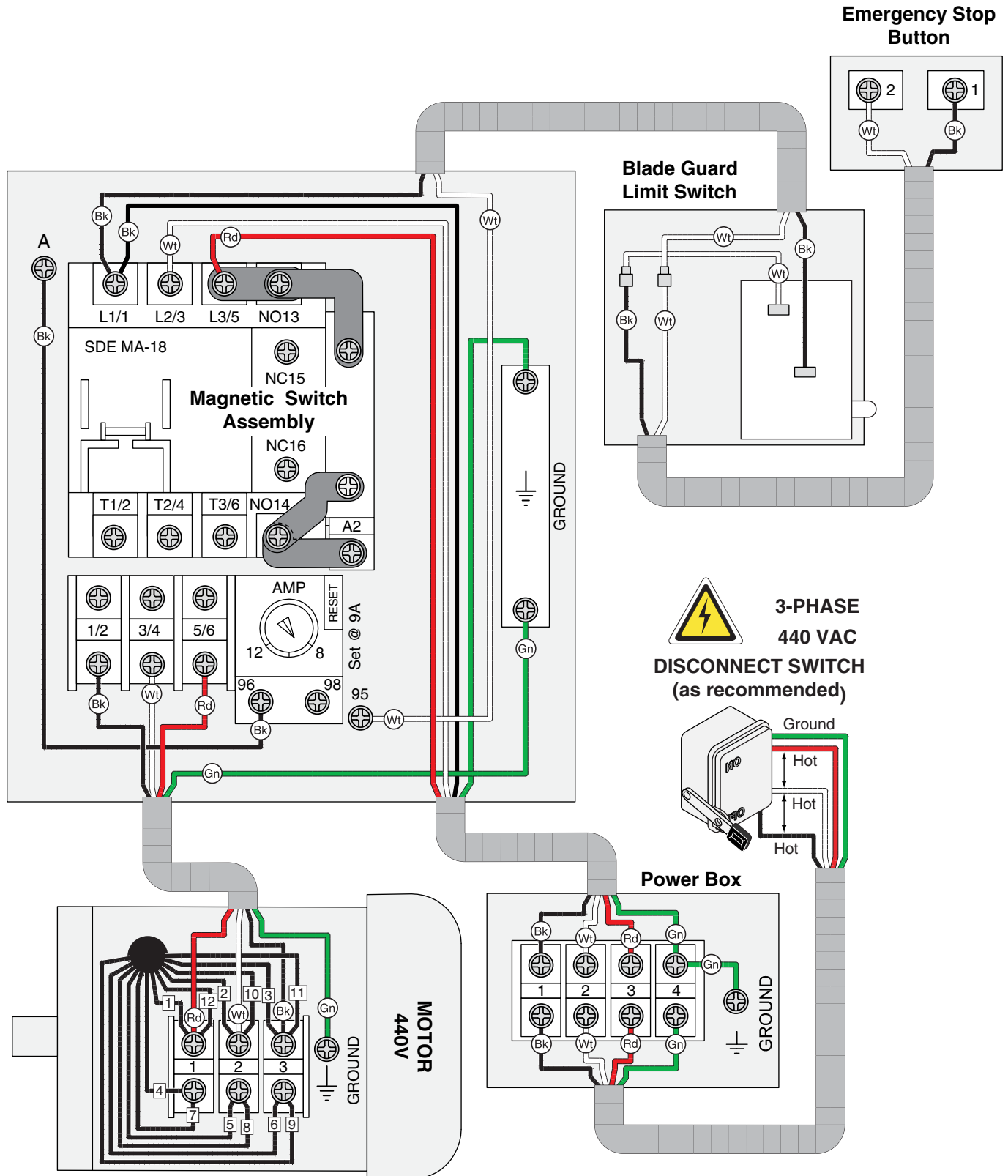




# G0623X3 7.5 HP 220V Wiring Diagram



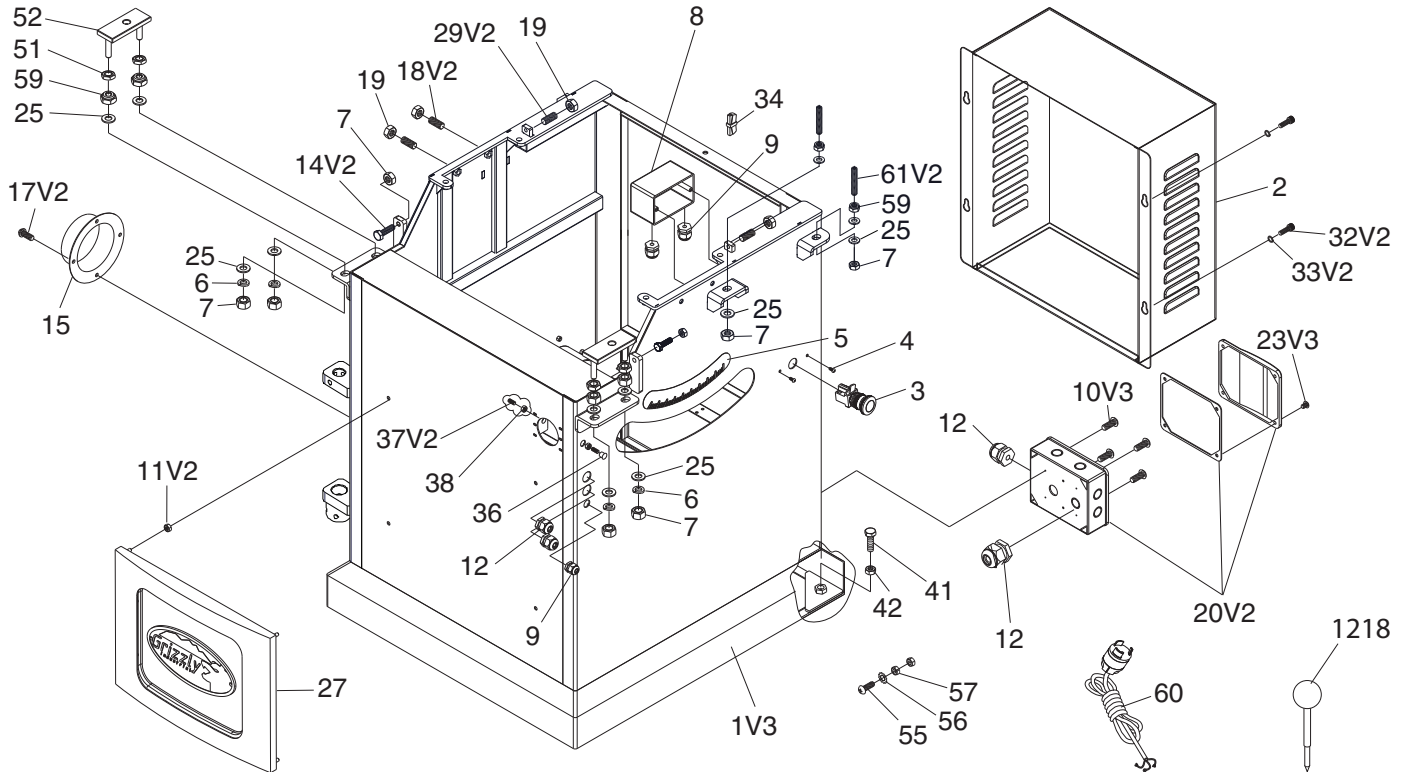
# G0623X3 7.5 HP 440V Wiring Diagram



# SECTION 10: PARTS

We do our best to stock replacement parts when possible, but we cannot guarantee that all parts shown are available for purchase. Call (800) 523-4777 or visit [www.grizzly.com/parts](http://www.grizzly.com/parts) to check for availability.

## Cabinet

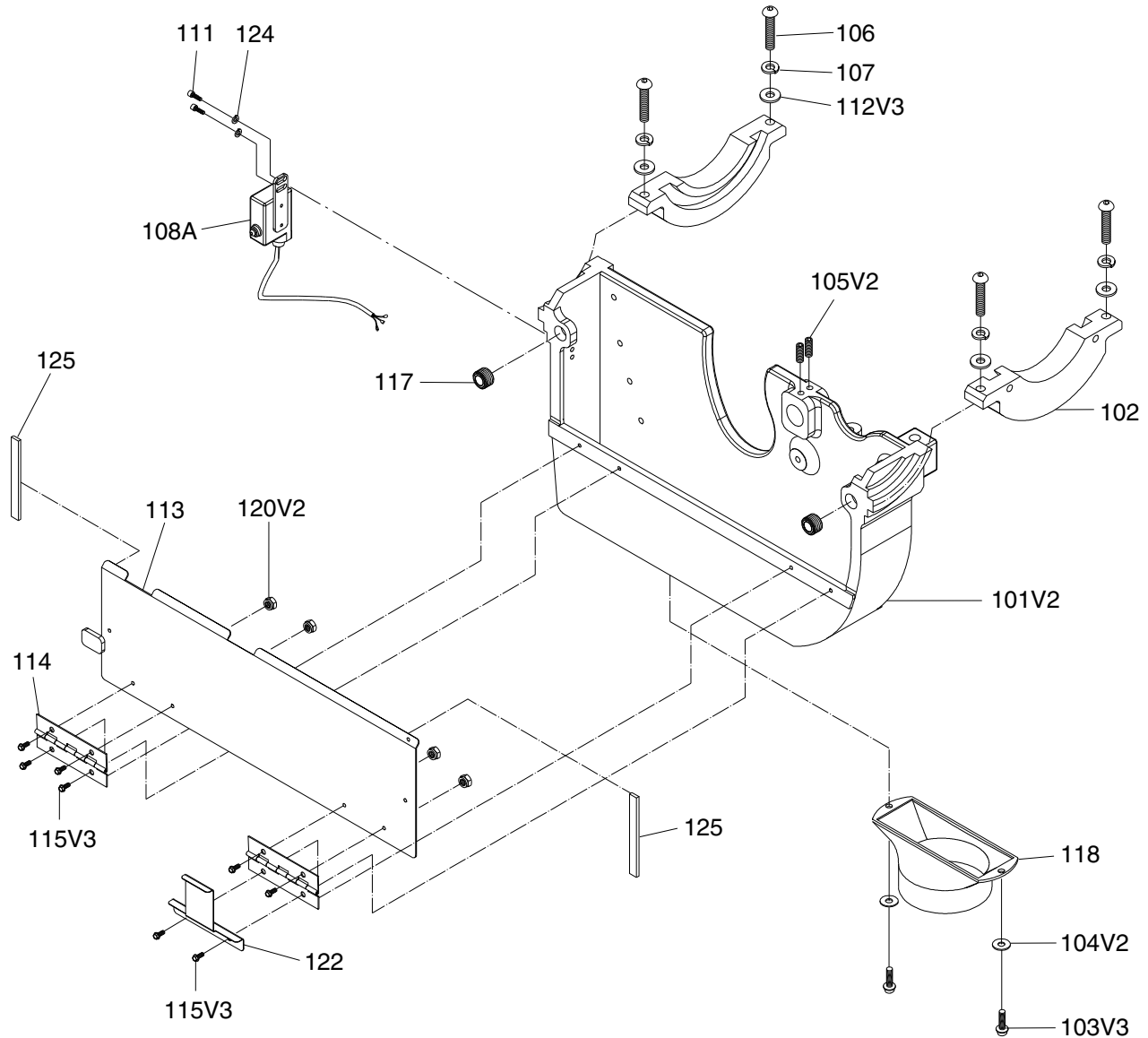


REF	PART #	DESCRIPTION
1V3	P0623X0001V3	CABINET V3.10.16
2	P0623X0002	COVER PLATE
3	P0623X0003	EMERGENCY STOP BUTTON
4	P0623X0004	TAP SCREW M5 X 16
5	P0623X0005	BLADE TILT SCALE
6	P0623X0006	LOCK WASHER 10MM
7	P0623X0007	HEX NUT M10-1.5
8	P0623X0008	SWITCH BOX
9	P0623X0009	STRAIN RELIEF TYPE-3 PG-9
10V3	P0623X0010V3	FLANGE SCREW M6-1 X 10
11V2	P0623X0011V2	FLANGE NUT M6-1
12	P0623X0012	STRAIN RELIEF TYPE-3 PG-13.5
14V2	P0623X0014V2	HEX BOLT M10-1.5 X 35
15	P0623X0015	DUST PORT 4"
17V2	P0623X0017V2	FLANGE SCREW M6-1 X 10
18V2	P0623X0018V2	SET SCREW M8-1.25 X 30
19	P0623X0019	HEX NUT M8-1.25
20V2	P0623X0020V2	JUNCTION BOX V2.08.14
23V3	P0623X0023V3	PHLP HD SCR M5-.8 X 20
25	P0623X0025	FENDER WASHER 10MM

REF	PART #	DESCRIPTION
27	P0623X0027	DECORATIVE PLATE
29V2	P0623X0029V2	SET SCREW M8-1.25 X 30
32V2	P0623X0032V2	BUTTON HD CAP SCR M8-1.25 X 16
33V2	P0623X0033V2	LOCK WASHER 8MM
34	P0623X0034	WIRE CONNECTOR
36	P0623X0036	PLUG 10MM
37V2	P0623X0037V2	SET SCREW M12-1.75 X 30
38	P0623X0038	HEX NUT M12-1.75
41	P0623X0041	HEX BOLT M12-1.75 X 40
42	P0623X0042	HEX NUT M12-1.75
51	P0623X0051	HEX NUT M10-1.5 THIN
52	P0623X0052	S. TABLE MOUNTING PLATE
55	P0623X0055	PHLP HD SCR M5-.8 X 25
56	P0623X0056	EXT TOOTH WASHER 5MM
57	P0623X0057	HEX NUT M5-.8
59	P0623X0059	LOCK NUT M10-1.5
60	P0623X0060	POWER CORD 12AWG 3W 72" L6-30P
61V2	P0623X0061V2	SET SCREW M10-1.5 X 90
1218	P0623X1218	ARBOR LOCK TOOL



# Main Trunnion



REF	PART #	DESCRIPTION
101V2	P0623X0101V2	CHANNEL BASE BLADE SHROUD V2.12.12
102	P0623X0102	TRUNNION BRACKET
103V3	P0623X0103V3	FLANGE BOLT M5-.8 X 8
104V2	P0623X0104V2	FLAT WASHER 6MM
105V2	P0623X0105V2	SET SCREW M8-1.25 X 12
106	P0623X0106	BUTTON HD CAP SCR M8-1.25 X 35
107	P0623X0107	LOCK WASHER 8MM
108A	P0623X0108A	LIMIT SWITCH ASSEMBLY
111	P0623X0111	CAP SCREW M5-.8 X 10
112V3	P0623X0112V3	FLAT WASHER 8MM

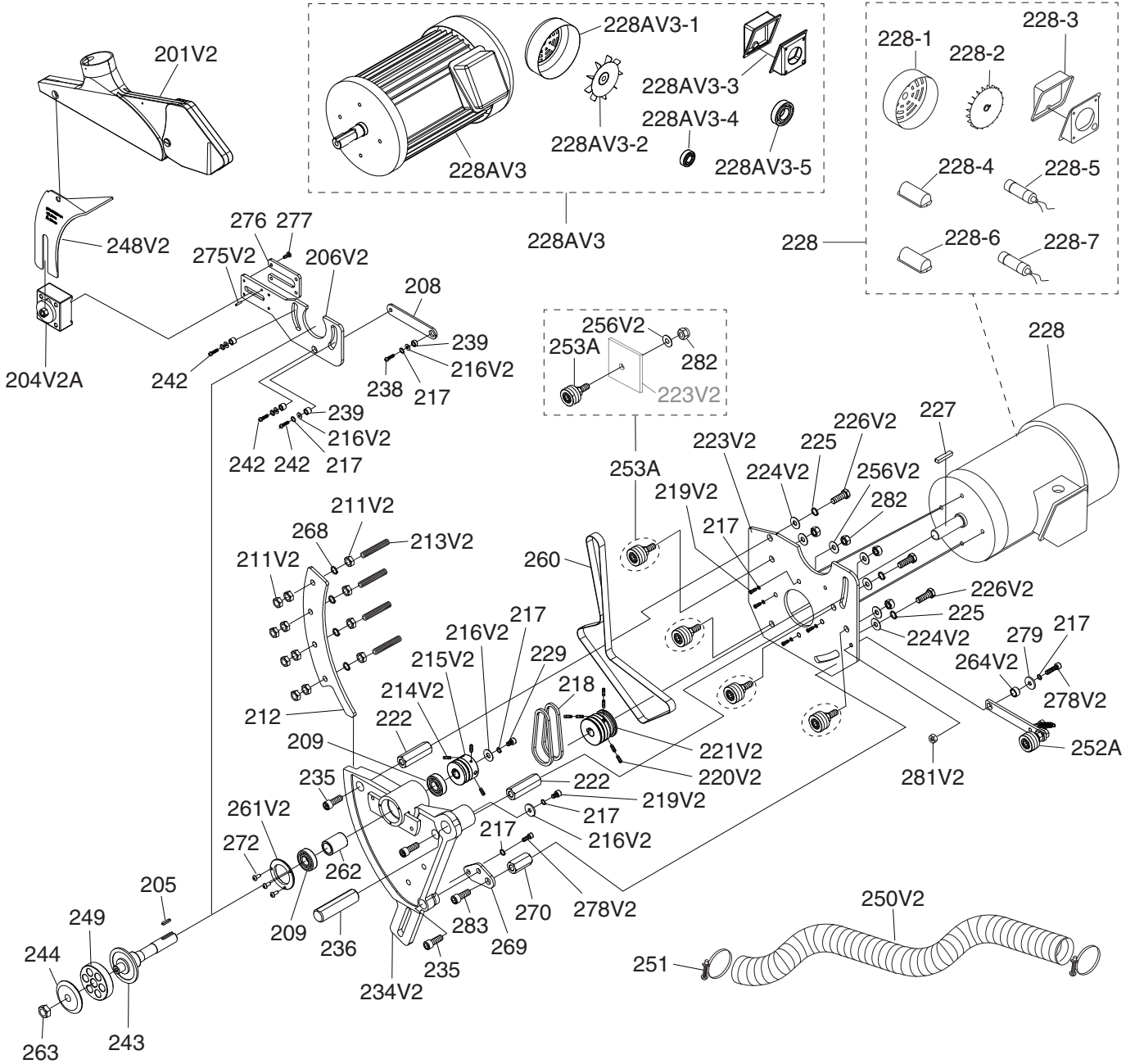
REF	PART #	DESCRIPTION
113	P0623X0113	BLADE GUARD PLATE
114	P0623X0114	HINGE
115V3	P0623X0115V3	FLANGE BOLT M5-.8 X 8
117	P0623X0117	MAGNET ASSEMBLY
118	P0623X0118	BLADE SHROUD DUST PORT
120V2	P0623X0120V2	FLANGE NUT M5-.8
122	P0623X0122	KEEPER PLATE
124	P0623X0124	LOCK WASHER 5MM
125	P0623X0125	PAD



# Main Motor

G0623X3 7.5-HP 220V/440V MOTOR

G0623X 5-HP 230V MOTOR



# Main Motor Parts List

REF	PART #	DESCRIPTION
201V2	P0623X0201V2	BLADE GUARD V2.02.12
204V2A	P0623X0204V2A	MOUNTING BLOCK ASSY V2.04.12
205	P0623X0205	KEY 5 X 5 X 20
206V2	P0623X0206V2	LOCATING BLOCK V2.08.10
208	P0623X0208	LINK PLATE
209	P0623X0209	BALL BEARING 6004LLB
211V2	P0623X0211V2	HEX NUT M10-1.5
212	P0623X0212	GIB PLATE
213V2	P0623X0213V2	SET SCREW M10-1.5 X 45
214V2	P0623X0214V2	SET SCREW M5-.8 X 10
215V2	P0623X0215V2	ARBOR PULLEY (FLAT) V2.01.08
216V2	P0623X0216V2	DOCK WASHER 8 X 30 X 3MM
217	P0623X0217	LOCK WASHER 8MM
218	P0623X0218	V-BELT M20 3L200
219V2	P0623X0219V2	CAP SCREW M8-1.25 X 20
220V2	P0623X0220V2	SET SCREW M8-1.25 X 8
221V2	P0623X0221V2	MOTOR PULLEY (TYPE-M20) V2.01.08
222	P0623X0222	HEX SHAFT M12-1.75 LONG
223V2	P0623X0223V2	MOTOR MOUNT PLATE V2.06.12
224V2	P0623X0224V2	DOCK WASHER 12 X 24 X 3MM
225	P0623X0225	LOCK WASHER 12MM
226V2	P0623X0226V2	HEX BOLT M12-1.75 X 30
227	P0623X0227	KEY 7 X 7 X 30
229	P0623X0229	CAP SCREW M8-1.25 X 20
234V2	P0623X0234V2	ROTATE PLATE V2.12.12
235	P0623X0235	CAP SCREW M12-1.75 X 45
236	P0623X0236	SHAFT
238	P0623X0238	BUTTON HD CAP SCR M8-1.25 X 20
239	P0623X0239	BUSHING 5MM
242	P0623X0242	BUTTON HD CAP SCR M8-1.25 X 16
243	P0623X0243	MAIN ARBOR CSA
244	P0623X0244	ARBOR FLANGE CSA
248V2	P0623X0248V2	RIVING KNIFE V2.05.12
249	P0623X0249	ARBOR WASHER CSA
250V2	P0623X0250V2	HOSE 3" X 37" V2.10.16
251	P0623X0251	HOSE CLAMP 3-1/4"
252A	P0623X0252A	ROTATING ARM IDLER ASSY

REF	PART #	DESCRIPTION
253A	P0623X0253A	IDLER PULLEY ASSY
256V2	P0623X0256V2	FLAT WASHER 12MM
260	P0623X0260	BELT 15 X 1140MM
261V2	P0623X0261V2	PLATE V2.08.14
262	P0623X0262	BUSHING
263	P0623X0263	ARBOR HEX NUT 5/8-12 LH
264V2	P0623X0264V2	BUSHING 6.1MM V2.10.16
268	P0623X0268	LOCK WASHER 10MM
269	P0623X0269	MOUNTING PLATE
270	P0623X0270	HEX SHAFT M12-1.75 SHORT
272	P0623X0272	BUTTON HD CAP SCR M5-.8 X 12
275V2	P0623X0275V2	ROLL PIN 4 X 10
276	P0623X0276	SECONDARY BLOCK
277	P0623X0277	BUTTON HD CAP SCR M5-.8 X 8
278V2	P0623X0278V2	CAP SCREW M8-1.25 X 20
279	P0623X0279	FLAT WASHER 8MM
281V2	P0623X0281V2	HEX NUT M8-1.25
282	P0623X0282	LOCK NUT M12-1.75
283	P0623X0283	CAP SCREW M12-1.75 X 25

## G0623X 5HP, 230V, SINGLE-PHASE MOTOR

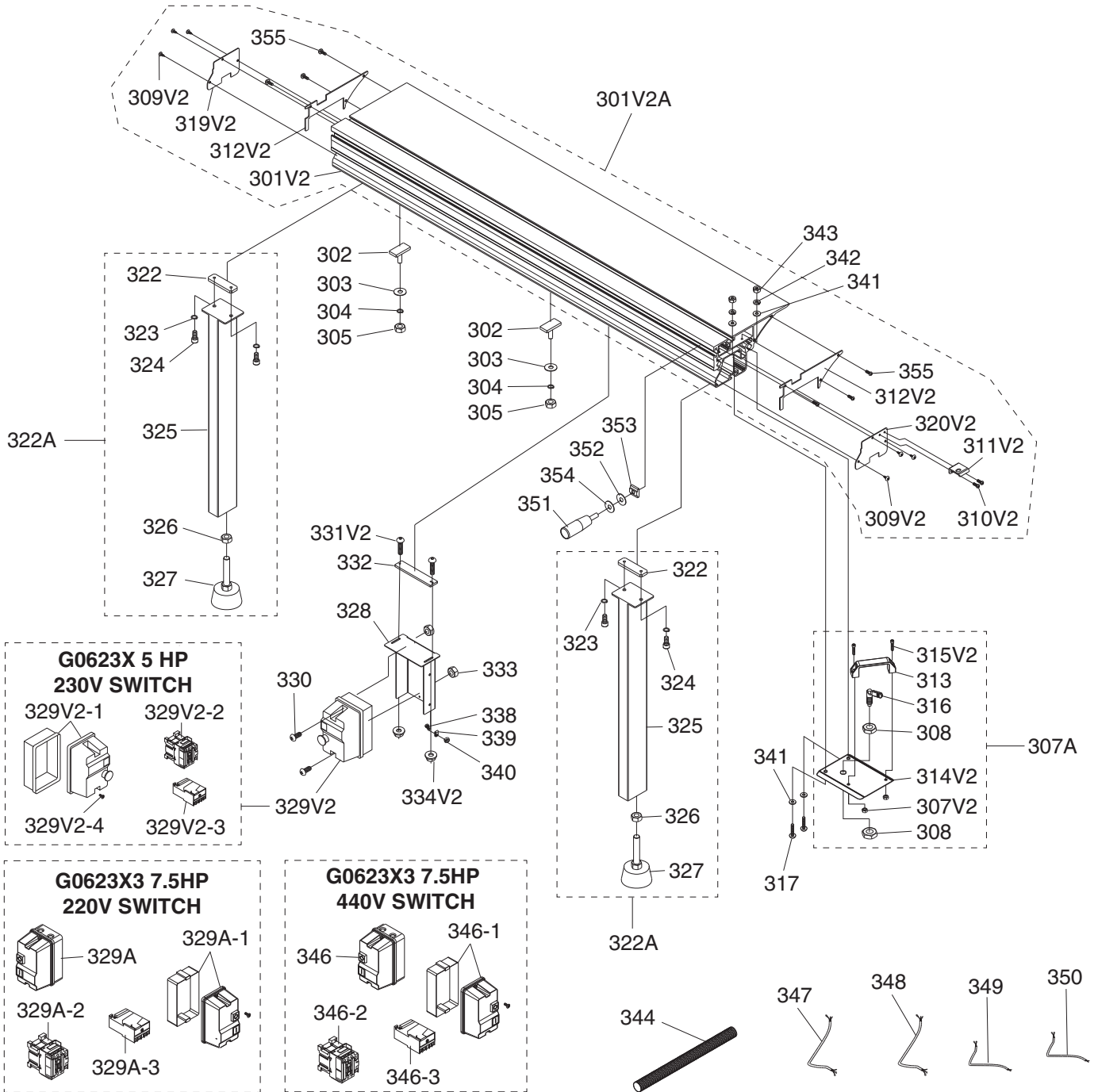
228	P0623X0228	MOTOR 5HP 230V 1-PH
228-1	P0623X0228-1	MOTOR FAN COVER
228-2	P0623X0228-2	MOTOR FAN
228-3	P0623X0228-3	JUNCTION BOX
228-4	P0623X0228-4	CAPACITOR COVER
228-5	P0623X0228-5	S CAPACITOR 400M 250V 1-3/4 X 3-1/2
228-6	P0623X0228-6	CAPACITOR COVER
228-7	P0623X0228-7	R CAPACITOR 30M 500V 1-1/2 X 3-3/8

## G0623X3 7.5HP, 220/440V 3-PHASE MOTOR

228AV3	P0623X30228AV3	MOTOR 7.5 HP 220V 3-PH V3.10.16
228AV3-1	P0623X30228AV3-1	MOTOR FAN COVER
228AV3-2	P0623X30228AV3-2	MOTOR FAN
228AV3-3	P0623X30228AV3-3	JUNCTION BOX
228AV3-4	P0623X30228AV3-4	BALL BEARING 6203ZZ
228AV3-5	P0623X30228AV3-5	BALL BEARING 6206ZZ



# Sliding Table



# Sliding Table Parts List

REF	PART #	DESCRIPTION
301V2	P0623X0301V2	SLIDING TABLE W/BASE 688 X 316 V2.03.14
301V2A	P0623X0301V2A	SLIDING TABLE ASSEMBLY V2.03.14
302	P0623X0302	T-SCREW M12-1.75 X 35
303	P0623X0303	FLAT WASHER 12MM
304	P0623X0304	LOCK WASHER 12MM
305	P0623X0305	HEX NUT M12-1.75
307V2	P0623X0307V2	HEX NUT M8-1.25 THIN
307A	P0623X0307A	S. TABLE HANDLE PLATE ASSY
308	P0623X0308	HEX NUT M16-1.5 THIN
309V2	P0623X0309V2	TAP SCREW M4 X 8
310V2	P0623X0310V2	BUTTON HD CAP SCR M6-1 X 12
311V2	P0623X0311V2	LOCK RECEIVER PLATE V2.03.14
312V2	P0623X0312V2	S. TABLE END PLATE (UPPER) V2.03.14
313	P0623X0313	HANDLE
314V2	P0623X0314V2	S. TABLE HANDLE PLATE V2.03.14
315V2	P0623X0315V2	CAP SCREW M8-1.25 X 16
316	P0623X0316	PIN LOCK
317	P0623X0317	BUTTON HD CAP SCR M6-1 X 16
319V2	P0623X0319V2	SLIDING TABLE END PLATE (FR) V2.03.14
320V2	P0623X0320V2	SLIDING TABLE END PLATE (RR) V2.03.14
322	P0623X0322	SUPPORT LEG T-SLOT PLATE
322A	P0623X0322A	SUPPORT LEG ASSEMBLY
323	P0623X0323	LOCK WASHER 8MM
324	P0623X0324	CAP SCREW M8-1.25 X 20
325	P0623X0325	SUPPORT LEG
326	P0623X0326	HEX NUT M12-1.75
327	P0623X0327	ADJUST FOOT
328	P0623X0328	SWITCH MOUNTING BRACKET
330	P0623X0330	PHLP HD SCR M4-.7 X 16
331V2	P0623X0331V2	BUTTON HD CAP SCR M5-.8 X 25
332	P0623X0332	SWITCH T-SLOT PLATE
333	P0623X0333	HEX NUT M5-.8
334V2	P0623X0334V2	FLANGE NUT M5-.8
338	P0623X0338	CAP SCREW M5-.8 X 12
339	P0623X0339	FLAT WASHER 5MM

REF	PART #	DESCRIPTION
340	P0623X0340	HEX NUT M5-.8
341	P0623X0341	FLAT WASHER 6MM
342	P0623X0342	LOCK WASHER 6MM
343	P0623X0343	HEX NUT M6-1
344	P0623X0344	FLEXIBLE CONDUIT
347	P0623X0347	MOTOR CORD 12G 4W
348	P0623X0348	POWER BOX CORD 12G 3W (G0623X)
348	P0623X030348	POWER BOX CORD 12G 4W (G0623X3)
349	P0623X0349	LIMIT SWITCH CORD 18G 2W
350	P0623X0350	E-STOP CORD 18G 2W
351	P0623X0351	FIXED HANDLE 30 X 132, M12-1.75 X 14
352	P0623X0352	PLASTIC WASHER 12MM
353	P0623X0353	T-NUT M12-1.75
354	P0623X0354	FENDER WASHER 12MM
355	P0623X0355	BUTTON HD CAP SCR M5-.8 X 10

## G0623X 5HP, 230V, 1-PH SWITCH

329V2	P0623X0329V2	MAG SWITCH NHD MS 1-18D V2.09.10
329V2-1	P0623X0329V2-1	SWITCH BOX NHD
329V2-2	P0623X0329V2-2	CONTACTOR NHD C-18D 230V
329V2-3	P0623X0329V2-3	OL RELAY NHD NTH-21 17-21A
329V2-4	P0623X0329V2-4	WHITE SWITCH COVER SCREW

## G0623X3 7.5HP, 220V, 3-PH SWITCH

329A	P0623X30329A	SWITCH MP-18 7.5HP 220V 3PH
329A-1	P0623X30329A-1	SWITCH BOX
329A-2	P0623X30329A-2	CONTACTOR SDE MA-18 220V
329A-3	P0623X30329A-3	RELAY SDE RA-30 18-26A

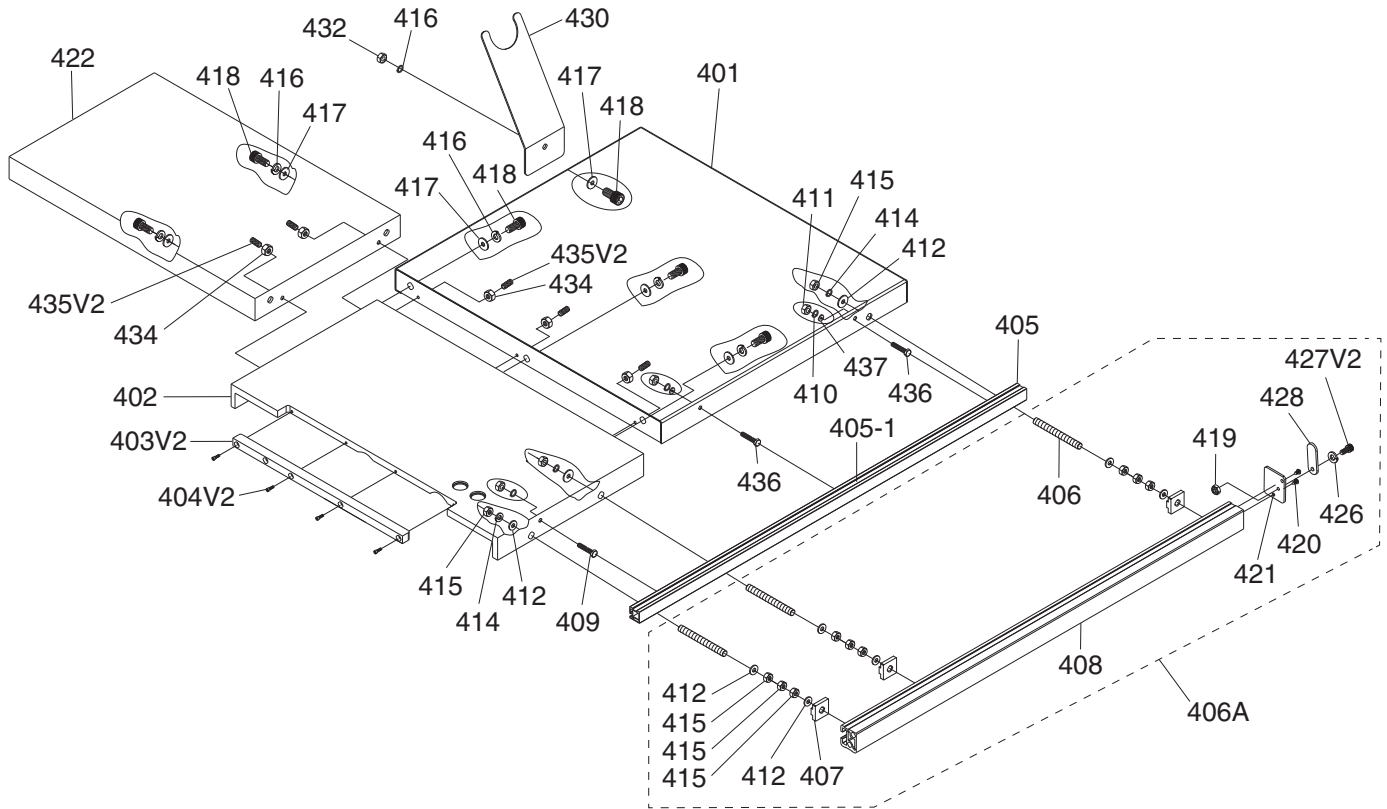
## G0623X3 7.5HP, 440V, 3-PH SWITCH

346	P0623X30346	MAG SWITCH MP-18 7.5HP 440V 3PH
346-1	P0623X30346-1	SWITCH BOX
346-2	P0623X30346-2	CONTACTOR SDE MA-18 440V
346-3	P0623X30346-3	RELAY SDE RA-20 8-12A





# Tables

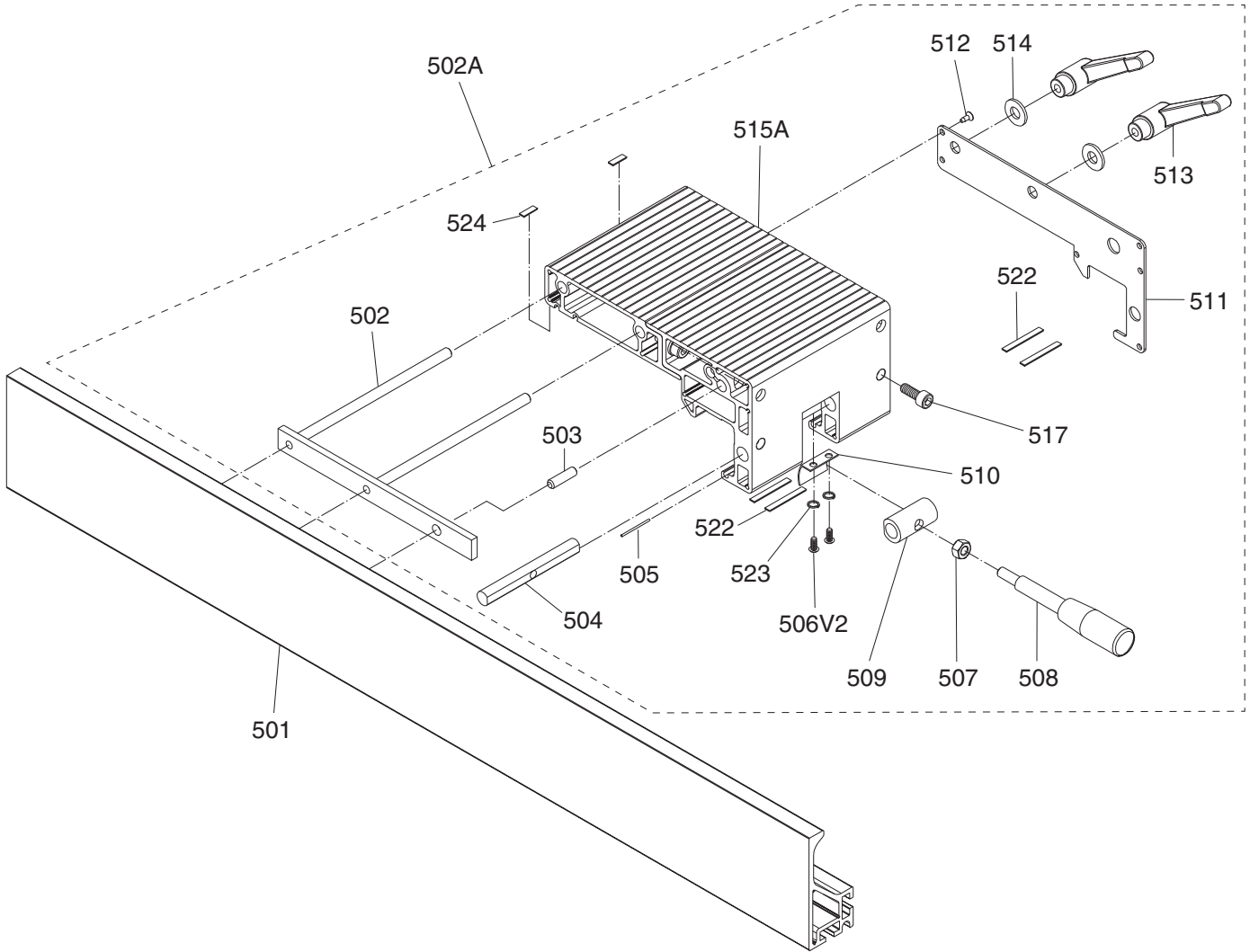


REF	PART #	DESCRIPTION
401	P0623X0401	LARGE EXTENSION TABLE
402	P0623X0402	CAST IRON TABLE
403V2	P0623X0403V2	TABLE INSERT (ALUM.) V2.11.16
404V2	P0623X0404V2	BUTTON HD CAP SCR M5-.8 X 12
405	P0623X0405	RAIL SCALE
405-1	P0623X0405-1	SCALE 0-39.25"
406	P0623X0406	STUD-FT M12-1.75 X 90
406A	P0623X0406A	RIP FENCE RAIL ASSEMBLY
407	P0623X0407	T-NUT M12-1.75
408	P0623X0408	RIP FENCE RAIL
409	P0623X0409	HEX BOLT M6-1 X 25
410	P0623X0410	LOCK WASHER 6MM
411	P0623X0411	HEX NUT M6-1
412	P0623X0412	FLAT WASHER 12MM
414	P0623X0414	LOCK WASHER 12MM
415	P0623X0415	HEX NUT M12-1.75

REF	PART #	DESCRIPTION
416	P0623X0416	LOCK WASHER 10MM
417	P0623X0417	FLAT WASHER 10MM
418	P0623X0418	CAP SCREW M10-1.5 X 25
419	P0623X0419	LOCK NUT M5-.8
420	P0623X0420	TAP SCREW M4 X 10
421	P0623X0421	RAIL END PLATE
422	P0623X0422	SMALL EXTENSION TABLE
426	P0623X0426	LOCK WASHER 5MM
427V2	P0623X0427V2	CAP SCREW M5-.8 X 12
428	P0623X0428	STOP TAB
430	P0623X0430	DUST HOSE SUPPORT
432	P0623X0432	LOCK NUT M10-1.5
434	P0623X0434	HEX NUT M8-1.25
435V2	P0623X0435V2	SET SCREW M8-1.25 X 25
436	P0623X0436	HEX BOLT M6-1 X 16
437	P0623X0437	FLAT WASHER 6MM



# Rip Fence

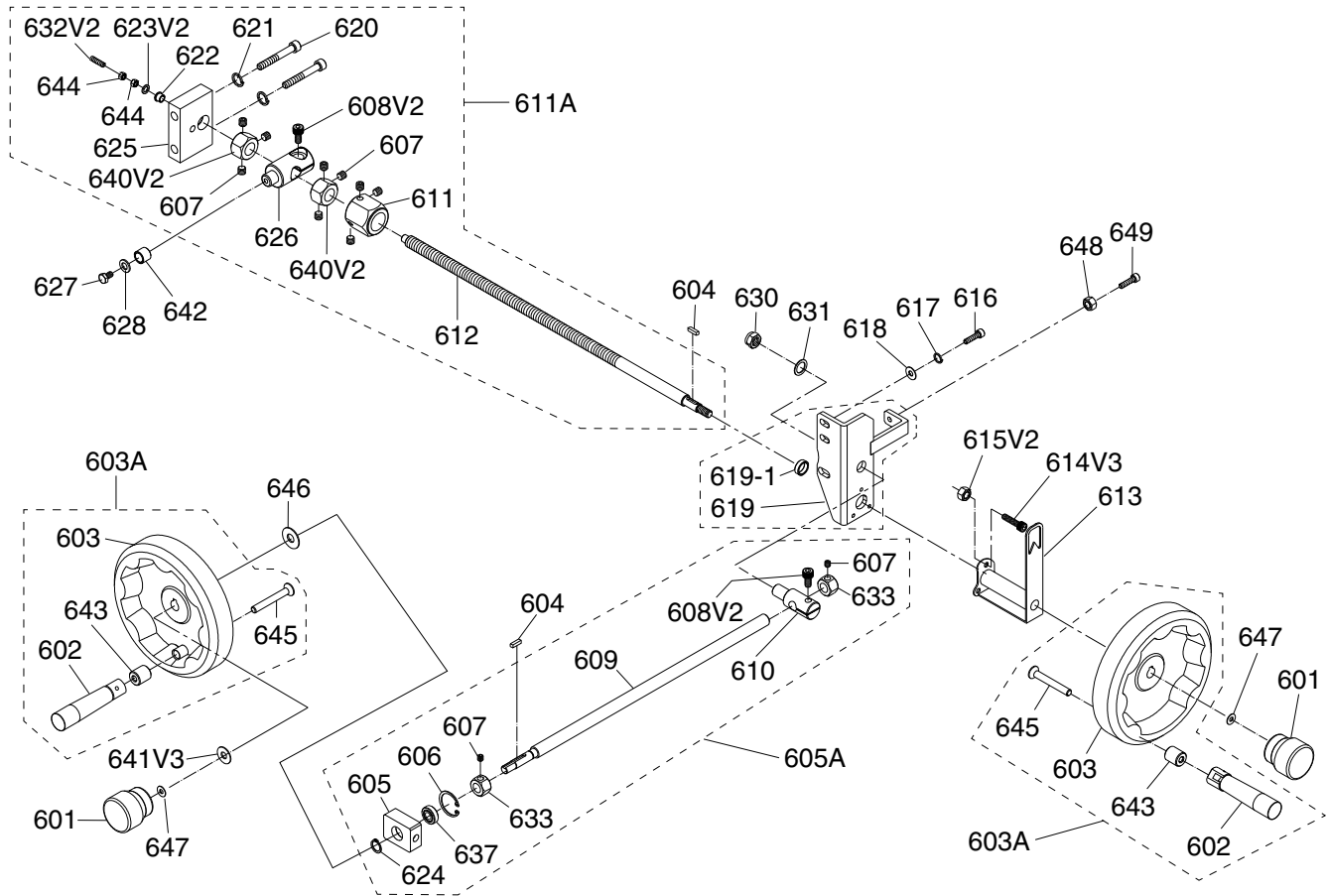


REF	PART #	DESCRIPTION
501	P0623X0501	RIP FENCE
502	P0623X0502	CLAMP PLATE
502A	P0623X0502A	REAR FENCE ASSEMBLY
503	P0623X0503	ROLL PIN 8 X 30
504	P0623X0504	ROD
505	P0623X0505	HDPE STRIP
506V2	P0623X0506V2	PHLP HD SCR M5-.8 X 10
507	P0623X0507	HEX NUT M8-1.25
508	P0623X0508	FIXED HANDLE 23 X 138, M8-1.25 X 22
509	P0623X0509	SLEEVE

REF	PART #	DESCRIPTION
510	P0623X0510	SPRING PRESSURE PLATE
511	P0623X0511	COVER PLATE
512	P0623X0512	TAP SCREW M4 X 8
513	P0623X0513	ADJ. HANDLE 67L, M8-1.25
514	P0623X0514	FLAT WASHER 8MM
515A	P0623X0515A	RIP FENCE HOUSING ASSY
517	P0623X0517	PLASTIC SCREW
522	P0623X0522	HDPE STRIP 50 X 5MM
523	P0623X0523	EXT TOOTH WASHER 5MM
524	P0623X0524	HDPE STRIP



# Handwheels

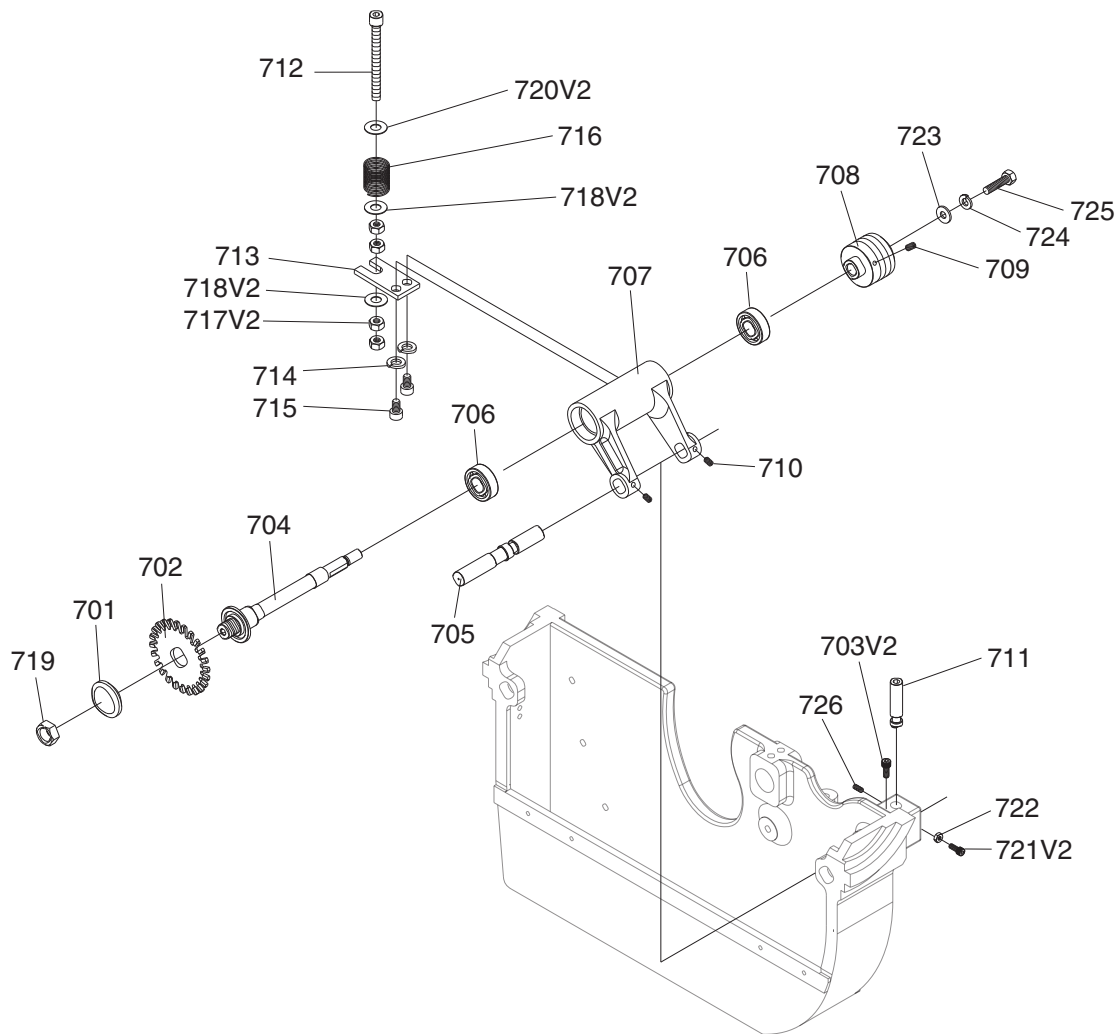


REF	PART #	DESCRIPTION
601	P0623X0601	LOCK KNOB M10-1.5, D50
602	P0623X0602	FOLDING HANDLE M6-1, 28 X 110
603	P0623X0603	HANDWHEEL TYPE-12 160D X 12B-K X M6-1
603A	P0623X0603A	HANDWHEEL ASSEMBLY
604	P0623X0604	MACHINE KEY 5 X 5 X 20
605	P0623X0605	ANGLE SEAT
605A	P0623X0605A	TILT MECHANISM ASSEMBLY
606	P0623X0606	INT RETAINING RING 28MM
607	P0623X0607	SET SCREW M6-1 X 6
608V2	P0623X0608V2	CAP SCREW M10-1.5 X 25
609	P0623X0609	LEADSCREW M16 X 2P X 2T
610	P0623X0610	LEADSCREW CAM
611	P0623X0611	LOCATE RING
611A	P0623X0611A	HEIGHT MECHANISM ASSY
612	P0623X0612	JACK SCREW M16 X 2P X 2T
613	P0623X0613	FINGER GUIDE
614V3	P0623X0614V3	CAP SCREW M6-1 X 16
615V2	P0623X0615V2	HEX NUT M6-1
616	P0623X0616	CAP SCREW M8-1.25 X 20
617	P0623X0617	LOCK WASHER 8MM
618	P0623X0618	FLAT WASHER 8MM
619	P0623X0619	STRUT BOARD
619-1	P0623X0619-1	SLEEVE
620	P0623X0620	CAP SCREW M8-1.25 X 50

REF	PART #	DESCRIPTION
621	P0623X0621	LOCK WASHER 8MM
622	P0623X0622	BEARING SELF-LUBRICATING
623V2	P0623X0623V2	FENDER WASHER 6MM
624	P0623X0624	EXT RETAINING RING 12MM
625	P0623X0625	LOCATE BLOCK
626	P0623X0626	JACK SCREW CAM
627	P0623X0627	CAP SCREW M6-1 X 10
628	P0623X0628	FLAT WASHER 6MM
630	P0623X0630	LOCK NUT M16-2
631	P0623X0631	FLAT WASHER 17 X 24MM, COPPER
632V2	P0623X0632V2	SET SCREW M6-1 X 30
633	P0623X0633	STOP NUT M16-2 (1 SET SCREW)
637	P0623X0637	BALL BEARING 6001ZZ
640V2	P0623X0640V2	STOP NUT M16-2 (3 SET SCREWS)
641V3	P0623X0641V3	DOCK WASHER 10 X 40 X 3 V3.09.17
642	P0623X0642	BUSHING
643	P0623X0643	HANDLE EXTENSION 7 X 20 X 22MM
644	P0623X0644	HEX NUT M6-1
645	P0623X0645	FLAT HD SCR M6-1 X 35
646	P0623X0646	DOCK WASHER 13 X 30 X 2.5MM
647	P0623X0647	FLAT WASHER 10MM
648	P0623X0648	HEX NUT M8-1.25
649	P0623X0649	CAP SCREW M8-1.25 X 25



# Scoring Trunnion

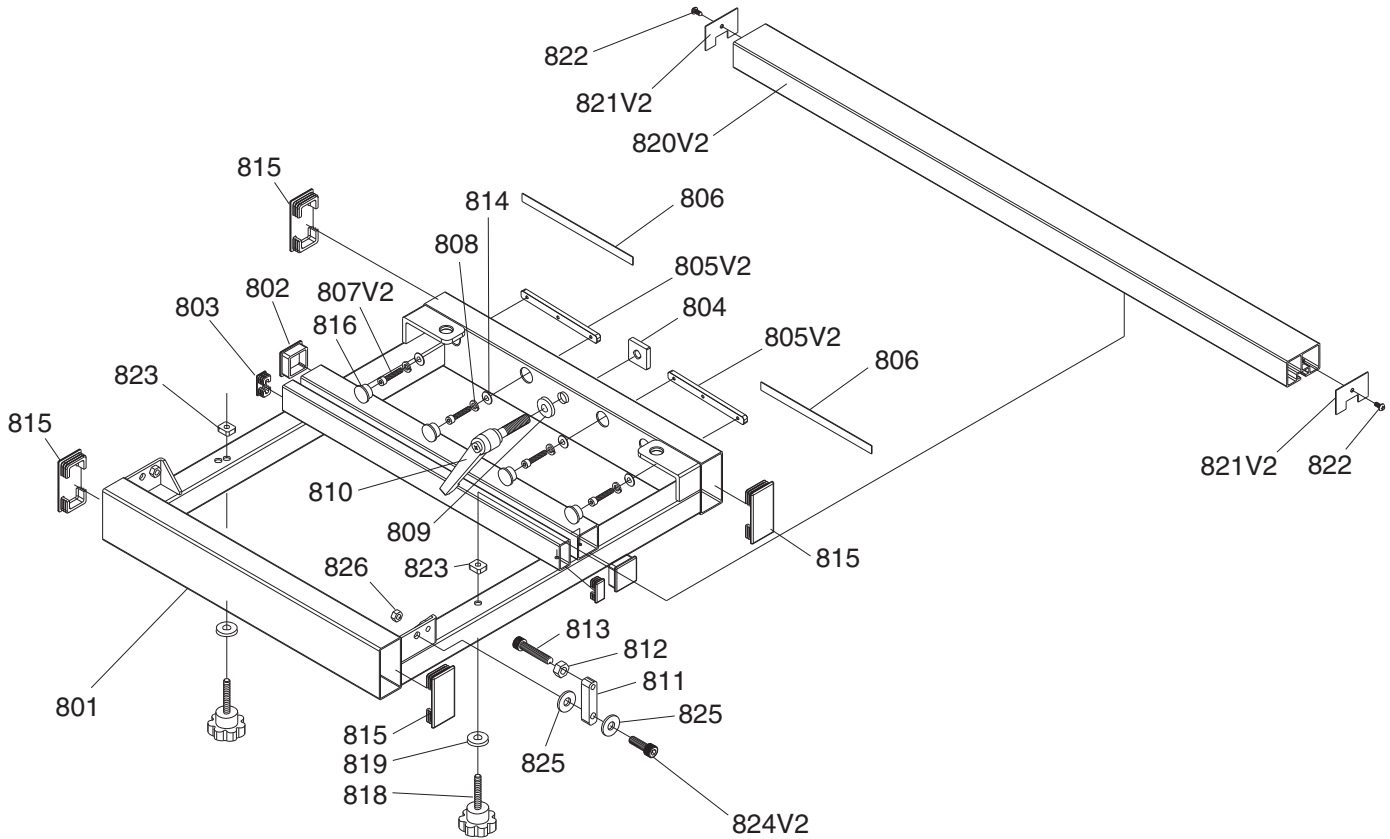


REF	PART #	DESCRIPTION
701	P0623X0701	ARBOR FLANGE
702	P0623X0702	SCORING SAW BLADE CSA 22MM
703V2	P0623X0703V2	CAP SCREW M8-1.25 X 25
704	P0623X0704	SHAFT CSA 22MM
705	P0623X0705	SHAFT
706	P0623X0706	BALL BEARING 6202LLB
707	P0623X0707	REGULATOR
708	P0623X0708	SCORING PULLEY 60HZ
709	P0623X0709	SET SCREW M6-1 X 6
710	P0623X0710	SET SCREW M6-1 X 6
711	P0623X0711	ADJUST SHAFT
712	P0623X0712	CAP SCREW M8-1.25 X 100
713	P0623X0713	PLATE

REF	PART #	DESCRIPTION
714	P0623X0714	LOCK WASHER 8MM
715	P0623X0715	CAP SCREW M8-1.25 X 25
716	P0623X0716	LOCK COMPRESSION SPRING
717V2	P0623X0717V2	HEX NUT M8-1.25
718V2	P0623X0718V2	DOCK WASHER 8 X 23 X 2MM
719	P0623X0719	HEX NUT M12-1.75 LH
720V2	P0623X0720V2	DOCK WASHER 8 X 18 X 2MM
721V2	P0623X0721V2	CAP SCREW M6-1 X 25
722	P0623X0722	HEX NUT M6-1
723	P0623X0723	DOCK WASHER 6 X 30 X 3MM
724	P0623X0724	LOCK WASHER 6MM
725	P0623X0725	HEX BOLT M6-1 X 16 LH
726	P0623X0726	SET SCREW M6-1 X 8



# Crosscut Table

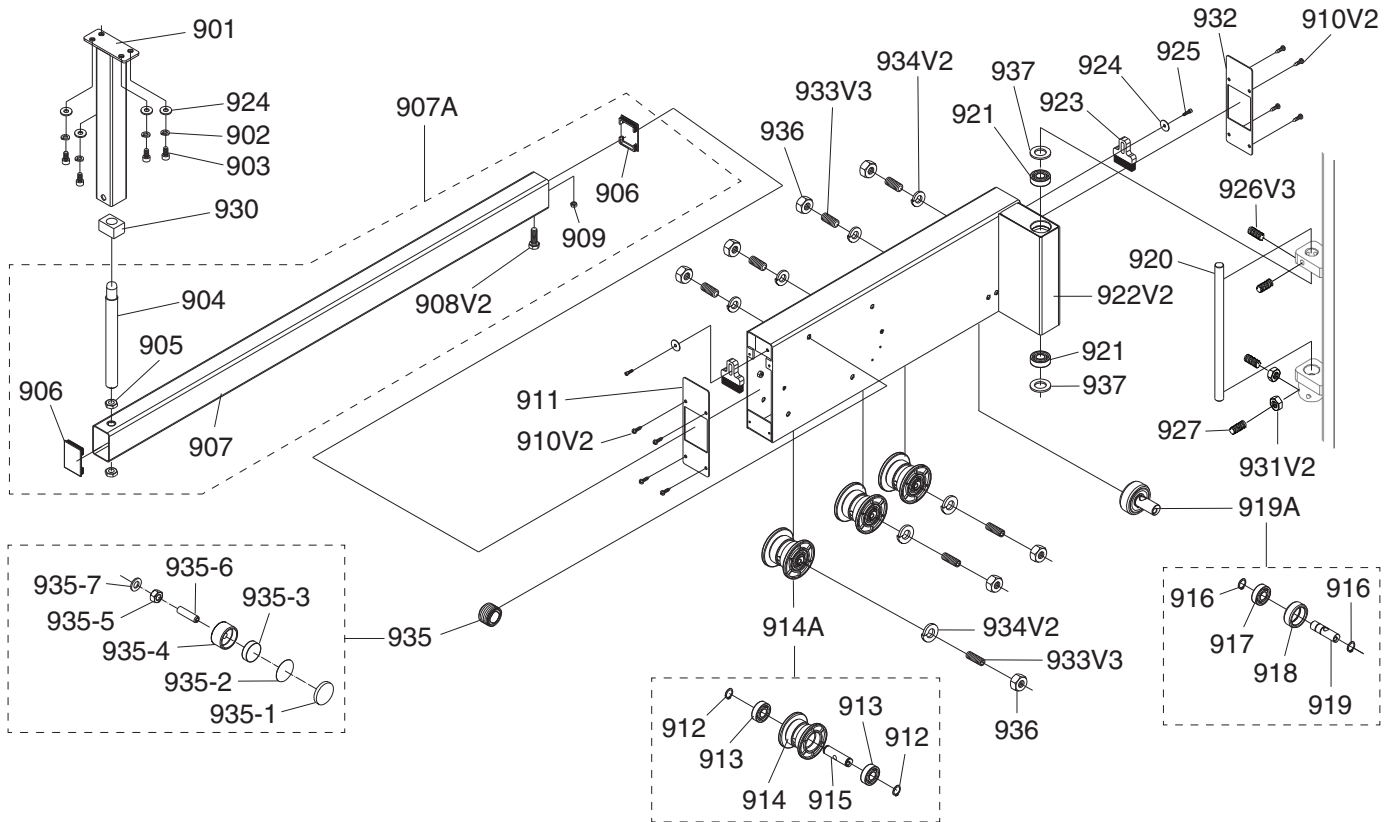


REF	PART #	DESCRIPTION
801	P0623X0801	SUPPORT FRAME
802	P0623X0802	PLUG 38 X 38MM
803	P0623X0803	PLUG 40 X 20MM
804	P0623X0804	T-NUT M12-1.75
805V2	P0623X0805V2	T-SLOT BAR V2.12.12
806	P0623X0806	PAD
807V2	P0623X0807V2	CAP SCREW M6-1 X 16
808	P0623X0808	LOCK WASHER 6MM
809	P0623X0809	FENDER WASHER 12MM
810	P0623X0810	ADJ. HANDLE 95L, M12-1.75 X 55
811	P0623X0811	FENCE ADJUSTMENT CAM
812	P0623X0812	HEX NUT M8-1.25
813	P0623X0813	HEX BOLT M8-1.25 X 40

REF	PART #	DESCRIPTION
814	P0623X0814	FLAT WASHER 6MM
815	P0623X0815	PLUG 80 X 40MM
816	P0623X0816	PLASTIC PLUG
818	P0623X0818	KNOB BOLT M8-1.25 X 50, 12-LOBE D50
819	P0623X0819	DOCK WASHER 8 X 30 X 3MM
820V2	P0623X0820V2	SQUARE BRACE 70MM WIDE V2.11.13
821V2	P0623X0821V2	COVER 70MM WIDE V2.11.13
822	P0623X0822	TAP SCREW #8 X 3/8
823	P0623X0823	T-NUT M8-1.25
824V2	P0623X0824V2	CAP SCREW M8-1.25 X 35
825	P0623X0825	FENDER WASHER 8MM
826	P0623X0826	LOCK NUT M8-1.25



# Swing Arm

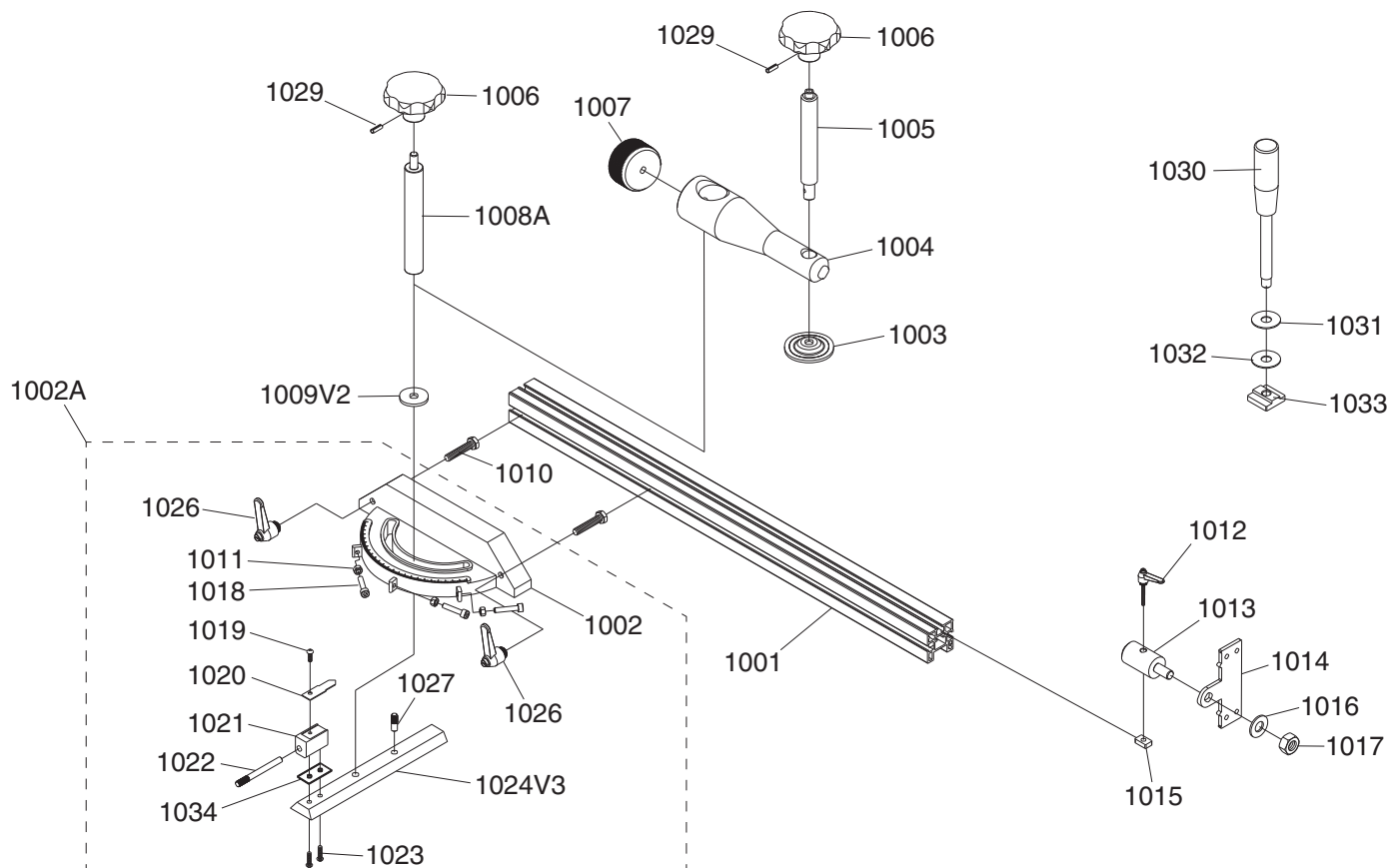


REF	PART #	DESCRIPTION
901	P0623X0901	CROSSCUT TABLE SUPPORT LEG
902	P0623X0902	LOCK WASHER 6MM
903	P0623X0903	CAP SCREW M6-1 X 16
904	P0623X0904	ROTARY SHAFT
905	P0623X0905	HEX NUT M20-2.5
906	P0623X0906	PLUG 40 X 80MM
907	P0623X0907	SLIDING TUBE
907A	P0623X0907A	SLIDING TUBE ASSEMBLY
908V2	P0623X0908V2	CAP SCREW M8-1.25 X 12
909	P0623X0909	HEX NUT M8-1.25
910V2	P0623X0910V2	BUTTON HD CAP SCR M4-.7 X 6
911	P0623X0911	COVER
912	P0623X0912	EXT RETAINING RING 15MM
913	P0623X0913	BALL BEARING 6202ZZ
914	P0623X0914	ROLLER
914A	P0623X0914A	ROLLER ASSEMBLY
915	P0623X0915	ADJUST SHAFT
916	P0623X0916	EXT RETAINING RING 15MM
917	P0623X0917	BALL BEARING 6202ZZ
918	P0623X0918	RING
919	P0623X0919	ADJUST SHAFT
919A	P0623X0919A	ADJUST SHAFT ASSEMBLY
920	P0623X0920	SWING ARM SHAFT

REF	PART #	DESCRIPTION
921	P0623X0921	BALL BEARING 6202ZZ
922V2	P0623X0922V2	SWING ARM V2.10.16
923	P0623X0923	BRUSH
924	P0623X0924	FLAT WASHER 6MM
925	P0623X0925	CAP SCREW M6-1 X 20
926V3	P0623X0926V3	SET SCREW M10-1.5 X 16
927	P0623X0927	SET SCREW M10-1.5 X 25
930	P0623X0930	ROTARY SHAFT COLLAR
931V2	P0623X0931V2	HEX NUT M10-1.5 THIN
932	P0623X0932	COVER
933V3	P0623X0933V3	SET SCREW M8-1.25 X 30
934V2	P0623X0934V2	LOCK WASHER 8MM
935	P0623X0935	MAGNET BASE ASSEMBLY
935-1	P0623X0935-1	FOAM GASKET 28MM
935-2	P0623X0935-2	RETAINING RING 28MM
935-3	P0623X0935-3	MAGNET
935-4	P0623X0935-4	MAGNET BASE
935-5	P0623X0935-5	HEX NUT M8-1.25
935-6	P0623X0935-6	SET SCREW M8-1.25 X 35
935-7	P0623X0935-7	FENDER WASHER 8MM
936	P0623X0936	HEX NUT M8-1.25
937	P0623X0937	DOCK WASHER 17 X 30 X 3MM



# Miter Gauge

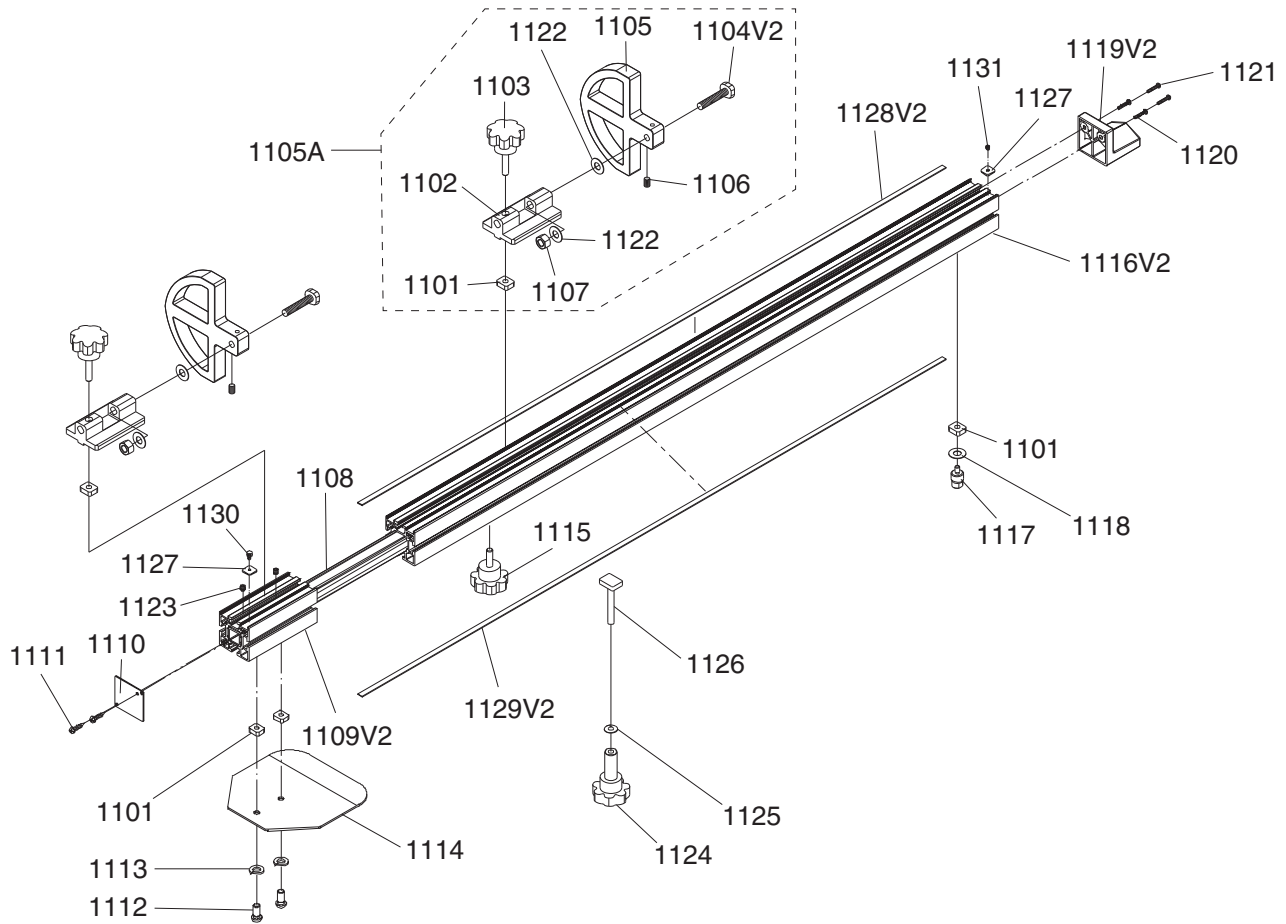


REF	PART #	DESCRIPTION
1001	P0623X1001	MITER GAUGE FENCE
1002	P0623X1002	MITER GAUGE BODY
1002A	P0623X1002A	MITER GAUGE BODY ASSEMBLY
1003	P0623X1003	LARGE WASHER
1004	P0623X1004	SLIDING MITER CLAMP SHAFT
1005	P0623X1005	CLAMP SHAFT
1006	P0623X1006	KNOB (PINNED) 7-LOBE D60
1007	P0623X1007	KNOB (KNURLED) 36D X 20L
1008A	P0623X1008A	MITER HANDLE SHAFT ASSY
1009V2	P0623X1009V2	DOCK WASHER 10 X 27 X 3MM
1010	P0623X1010	HEX BOLT M6-1 X 30
1011	P0623X1011	HEX NUT M5-.8
1012	P0623X1012	ADJ. HANDLE 65L, M6-1 X 30
1013	P0623X1013	LOCK SHAFT
1014	P0623X1014	MITER FLIP STOP
1015	P0623X1015	SQUARE NUT M6-1
1016	P0623X1016	FLAT WASHER 10MM

REF	PART #	DESCRIPTION
1017	P0623X1017	LOCK NUT M10-1.5
1018	P0623X1018	CAP SCREW M5-.8 X 25
1019	P0623X1019	PHLP HD SCR M4-.7 X 12
1020	P0623X1020	POINTER
1021	P0623X1021	FIXED BLOCK
1022	P0623X1022	STOP BAR
1023	P0623X1023	PHLP HD SCR M4-.7 X 16
1024V3	P0623X1024V3	MITER GAUGE BAR V3.10.16
1026	P0623X1026	ADJUSTABLE HANDLE 42L, M6-1
1027	P0623X1027	SHAFT
1029	P0623X1029	ROLL PIN 3 X 20
1030	P0623X1030	FIXED HANDLE 30 X 132, M12-1.75 X 14
1031	P0623X1031	FLAT WASHER 12MM
1032	P0623X1032	FLAT WASHER 12MM PLASTIC
1033	P0623X1033	T-NUT M12-1.75
1034	P0623X1034	SPACING PLATE



# Crosscut Fence



REF	PART #	DESCRIPTION
1101	P0623X1101	T-NUT M8-1.25
1102	P0623X1102	STOP BRACKET
1103	P0623X1103	KNOB BOLT M8-1.25 X 40, 12-LOBE D50
1104V2	P0623X1104V2	T-BOLT M10-1.5 X 70 V2.09.17
1105	P0623X1105	FLIP STOP
1105A	P0623X1105A	FLIP STOP ASSEMBLY
1106	P0623X1106	SET SCREW M6-1 X 10
1107	P0623X1107	LOCK NUT M10-1.5
1108	P0623X1108	SQUARE TUBE
1109V2	P0623X1109V2	EXT FENCE V2.06.13
1110	P0623X1110	COVER
1111	P0623X1111	TAP SCREW M4 X 10
1112	P0623X1112	BUTTON HD CAP SCR M8-1.25 X 16
1113	P0623X1113	LOCK WASHER 8MM
1114	P0623X1114	LOCATE PLATE
1115	P0623X1115	KNOB BOLT M8-1.25 X 27 PLASTIC TIP

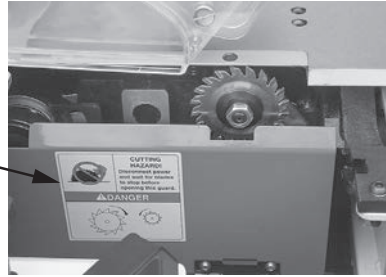
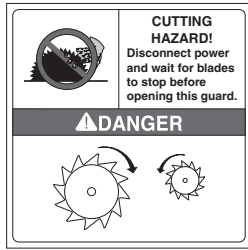
REF	PART #	DESCRIPTION
1116V2	P0623X1116V2	SQUARE FENCE V2.06.13
1117	P0623X1117	ROTATE SHAFT
1118	P0623X1118	FLAT WASHER 8MM
1119V2	P0623X1119V2	END PIECE ABS V2.06.13
1120	P0623X1120	PHLP HD SCR M4-.7 X 10
1121	P0623X1121	PHLP HD SCR M4-.7 X 35
1122	P0623X1122	FLAT WASHER 10MM BRASS
1123	P0623X1123	SET SCREW M6-1 X 6
1124	P0623X1124	KNOB M8-1.25, 12-LOBE, 60D X 75L
1125	P0623X1125	FENDER WASHER 8MM
1126	P0623X1126	T-BOLT M8-1.25 X 60
1127	P0623X1127	T-NUT M5-.8
1128V2	P0623X1128V2	SCALE 2000-0MM (78.75-0") ST V2.06.13
1129V2	P0623X1129V2	SCALE 0-2000MM (0-78.75") ST V2.06.13
1130	P0623X1130	CAP SCREW M5-.8 X 6
1131	P0623X1131	SET SCREW M5-.8 X 5



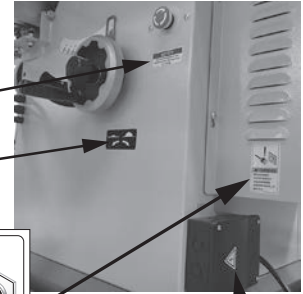
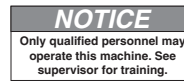


# Labels & Cosmetics

1205



1206



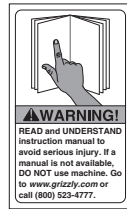
1214

1204



1207

1201



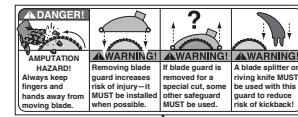
1208



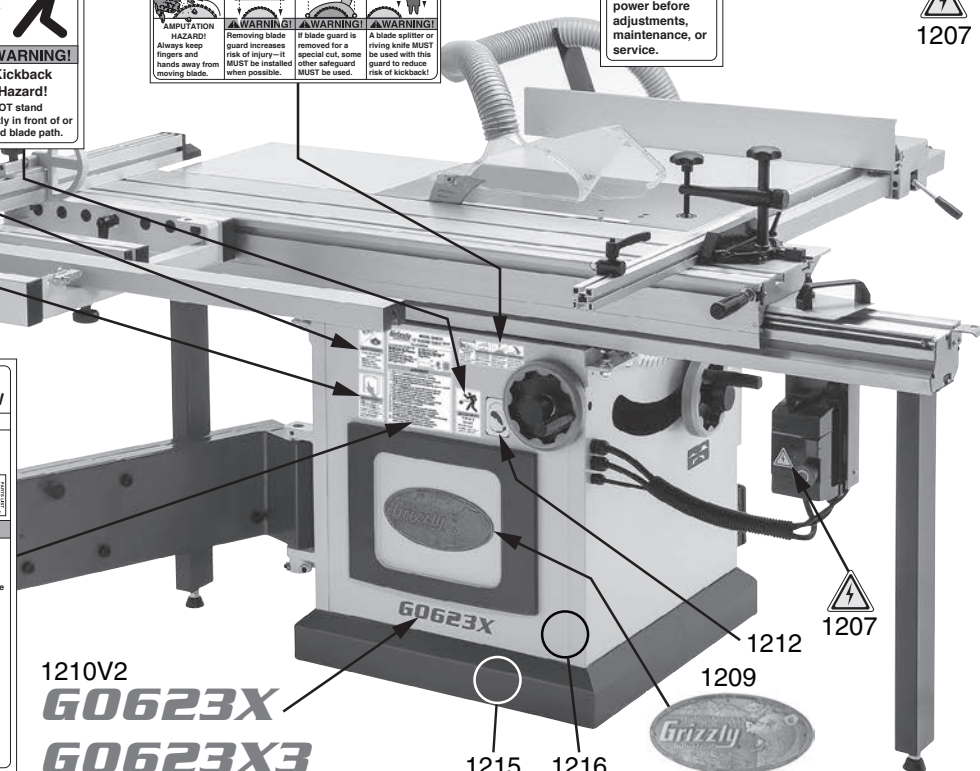
1203



1218



1211V3 1211V2



REF	PART #	DESCRIPTION
1201	P0623X1201	READ MANUAL LABEL
1203	P0623X1203	KICKBACK HAZARD LABEL
1204	P0623X1204	DISCONNECT POWER LABEL
1205	P0623X1205	BLADE GUARD DANGER LABEL
1206	P0623X1206	QUALIFIED PERSONNEL LABEL
1207	P0623X1207	ELECTRICITY LABEL
1208	P0623X1208	GLASSES/RESPIRATOR LABEL
1209	P0623X1209	GRIZZLY NAMEPLATE-SMALL
1210V2	P0623X1210V2	MODEL NO. LABEL V2.12.16 (G0623X)

REF	PART #	DESCRIPTION
1210V2	P0623X31210V2	MODEL NO. LABEL V2.12.16 (G0623X3)
1211V3	P0623X1211V3	MACHINE ID CSA V3.12.13 (G0623X)
1211V2	P0623X31211V2	MACHINE ID V2.12.13 (G0623X3)
1212	P0623X1212	BLADE TILT LABEL
1214	P0623X1214	BLADE ELEVATION LABEL
1215	P0623X1215	TOUCH-UP PAINT, GRIZZLY GREEN
1216	P0623X1216	TOUCH-UP PAINT, GRIZZLY PUTTY
1218	P0623X1218	BLADE WARNING LABEL

## WARNING

Safety labels warn about machine hazards and ways to prevent injury. The owner of this machine **MUST** maintain the original location and readability of the labels on the machine. If any label is removed or becomes unreadable, **REPLACE** that label before using the machine again. Contact Grizzly at (800) 523-4777 or [www.grizzly.com](http://www.grizzly.com) to order new labels.





# WARRANTY

---

---

Grizzly Industrial, Inc. warrants every product it sells for a period of **1 year** to the original purchaser from the date of purchase. This warranty does not apply to defects due directly or indirectly to misuse, abuse, negligence, accidents, repairs or alterations or lack of maintenance. This is Grizzly's sole written warranty and any and all warranties that may be implied by law, including any merchantability or fitness, for any particular purpose, are hereby limited to the duration of this written warranty. We do not warrant or represent that the merchandise complies with the provisions of any law or acts unless the manufacturer so warrants. In no event shall Grizzly's liability under this warranty exceed the purchase price paid for the product and any legal actions brought against Grizzly shall be tried in the State of Washington, County of Whatcom.

We shall in no event be liable for death, injuries to persons or property or for incidental, contingent, special, or consequential damages arising from the use of our products.

The manufacturers reserve the right to change specifications at any time because they constantly strive to achieve better quality equipment. We make every effort to ensure that our products meet high quality and durability standards and we hope you never need to use this warranty.

In the event you need to use this warranty, contact us by mail or phone and give us all the details. We will then issue you a "Return Number," which must be clearly posted on the outside as well as the inside of the carton. We will not accept any item back without this number. Proof of purchase must accompany the merchandise.

Please feel free to write or call us if you have any questions about the machine or the manual.

Thank you again for your business and continued support. We hope to serve you again soon.

To take advantage of this warranty, you must register it at <https://www.grizzly.com/forms/warranty>, or you can scan the QR code below to be automatically directed to our warranty registration page. Enter all applicable information for the product.



**grizzly.com**<sup>®</sup>  
**TOOL WEBSITE**

Buy Direct and Save with Grizzly<sup>®</sup> – Trusted, Proven and a Great Value!  
~Since 1983~

*Visit Our Website Today For  
Current Specials!*

**ORDER  
24 HOURS A DAY!  
1-800-523-4777**

