

Tetra Pak® Ice Cream Robot Filler M1

Smart and compact tub filling table

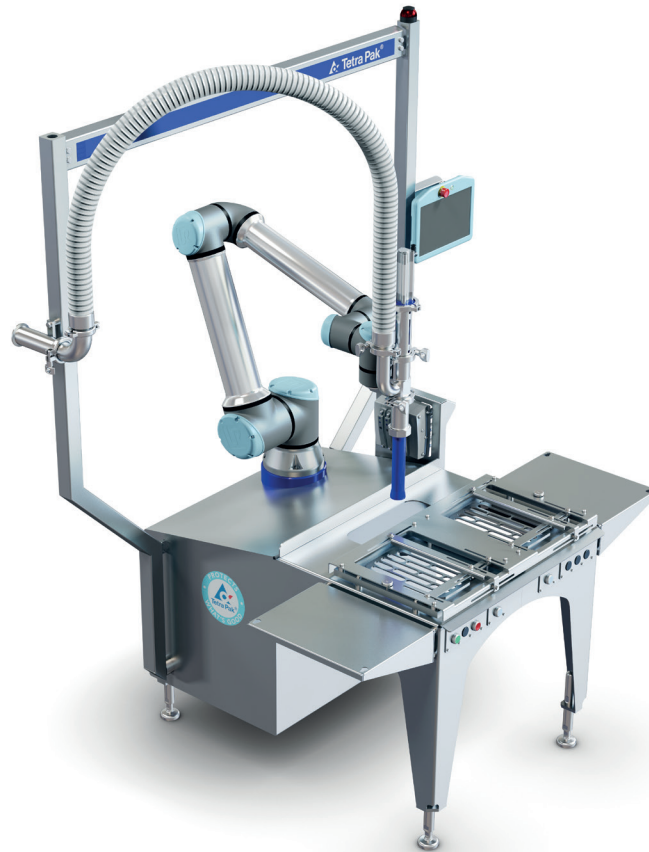

APPLICATION

Tetra Pak® Ice Cream Robot Filler M1 is an advanced, semi-automated unit for filling ice cream tub products with flexible, artisan-like patterns.

HIGHLIGHTS

- Collaborative robot
- No safety guarding required
- Flexible for many different products without size parts
- Artisan/handmade-style filling patterns
- Compact design
- Accurate filling
- Open design for easy cleaning

WORKING PRINCIPLE

Tetra Pak Ice Cream Robot Filler M1 consists of a wash-down filling table with two filling positions, a standby position for startup and hold mode, and a collaborative robot that guides the motion of the filling valve with filling nozzle for the desired filling motion pattern. The two filling positions include a set of adjustable tub

positioning guides, making it very quick and simple to change to additional tub and cup formats. The adjustable product/tub holding system can also easily be exchanged for a set prepared for another tub size. The filling motion pattern for each product size and shape can be selected from several preset motion patterns.

The motion pattern can be optimised to fit actual tub size and shape and to give the desired filling pattern, for example setting the number of filling stripes per layer, the number of layers, and the style of the final decoration pattern.

This dedicated motion setup can then be stored in the robot control system via the touch panel for each product or stock keeping unit (SKU).

Each dedicated motion setup also includes filling and ripple valve timings and a cycle time speed setting to match the incoming ice cream flow from the freezer(s) and desired line operation speed.

This enables a highly precise and repeated fill volume for each tub or cup, ensuring a very low standard deviation on filling weights.

The operation cycle follows a preset filling sequence:

1. The operator places an empty tub in the first filling position (right-hand side).
2. After the ice cream freezer starts and the ice cream reaches the right temperature and viscosity through the filling nozzle, the “filling sequence” can start.
3. The robot closes the filling and ripple valves and moves to the first filling position.
4. While the first tub is filled the operator can place an empty tub in the second filling position.
5. The robot follows the selected filling motion profile and fill timing to fill the first tub.
6. When the first tub filling is finalised, the filling valve and ripple valve close and the robot moves to the second filling position.
7. The same filling motion profile and fill timing is used to fill the second tub.
8. As the second tub is filled, the operator can remove the filled tub from the first filling position and replace it with an empty tub.
9. Etc.

STANDARD DESIGN

Tetra Pak Ice Cream Robot Filler M1 is a compact, semi-manual operated filling system mainly for cups and tubs in the 0.5 to 12 litre size range.

Use of an additional cassette system enables multiple smaller cups and cones to be filled on the table with good production capacity.

MAIN COMPONENTS

- Open-design filling table of stainless steel with support frame for the ice cream inlet and robot operator touch panel
- Built-in cabinet for the electrical control system
- Two filling positions with adjustable product/tub holding system
- One standby position for startup, with space for a waste bucket underneath

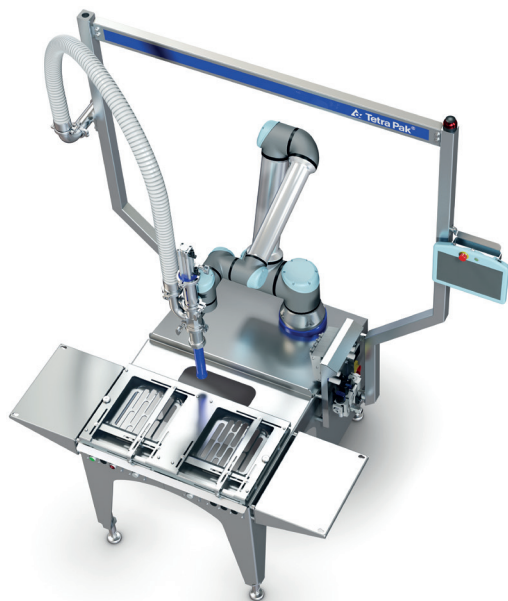

- Six-axis robot with collaborative operation setup for safe movement of the filling valve and filling nozzle during filling operation
- Filling valve with 2-inch clamp inlet and “plug closing” for ice cream with up to 16 mm hard inclusions and up to 30 mm soft inclusions, such as fruit pieces
- Filling nozzles for different tub sizes and flow rates are available:
 - Smooth surface filling
 - Decoration surface filling
- Two-inch ice cream inlet connection clamp with 2-inch flexible ice cream hose towards the filling valve inlet
- Robot control system for handling filling nozzle motions and fill timings
- Touchscreen operator panel

OPTIONS

- Additional filling nozzles of different lengths and outlet sizes
- Filling nozzles for addition of ripple sauce through the filling nozzle outlet, including the ripple dosing control valve
- Additional sets of the adjustable product/tub holding system to minimize product/SKU changeover time
- Filling cassettes for multifilling smaller cup and cone products, for example with a 3 x 4 pattern for up to ø72 mm cups or cones

CONTROL PANEL

Tetra Pak Ice Cream Robot Filler M1 is controlled by the built-in robot control system housed inside the stainless steel filling table.

Control functions are handled through the operator touch panel/robot user interface.

All product filling motion pattern setups are created, optimised and stored in the control memory.

Daily operation optimisations are performed easily on the touch panel.

Operation instructions – “preparation for startup with ice cream from the freezer”, “start of the automatic timed filling process”, “hold/standby mode” and “stop production” – are given simply via push buttons located on the front edge of the filling table.

When production ends, the optimised filling motion program for the product can be saved to memory by the touch panel.

Programs can be easily backed up on a USB stick.

Pneumatic activation of the filling valve and optional ripple control valve is done by the pneumatic control block on the right-hand wall of the filling table.

Valve timing is controlled directly from the robot control system according to the selected product function program.

CAPACITY

The adjustable product/tub holding system has a product size filling area of 265 mm x 360 mm in each of the two filling positions.

For single cups/tubs, up to 15 units can realistically be filled per minute. Typical limitations are filling motion speed or the manual tub replacement cycle function.

For small cups and cones in cassettes, up to 30 fill actions per minute.

LAYOUT

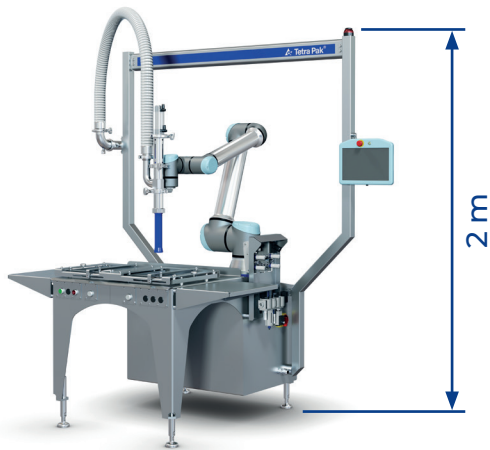

CONSUMPTION DATA

Electrical power

0.35 kW for the robot with controls

230 V, 50 Hz

Compressed air

Pneumatic module

10 N/h at 600 kPa (6 bar)

